



## MIC5295

### Low Quiescent Current, 150mA LDO Regulator

#### General Description

The MIC5295 is a 150mA highly accurate, low dropout regulator with high input voltage and low ground current. This combination of high voltage and low ground current makes the MIC5295 ideal for USB and portable electronics applications, using 1-cell, 2-cell or 3-cell Li-Ion battery inputs.

A  $\mu$ Cap LDO design, the MIC5295 is stable with either a ceramic or tantalum output capacitor. It only requires a 2.2 $\mu$ F capacitor for stability.

Features of the MIC5295 includes enable input, thermal shutdown, current limit, reverse battery protection, and reverse leakage protection.

Available in fixed and adjustable output voltage versions, the MIC5295 is offered in the TO-252-5 (D-Pak) package with a junction temperature range of  $-40^{\circ}\text{C}$  to  $+125^{\circ}\text{C}$ .

#### Features

- Wide input voltage range: 2.3V to 24V
- Ultra low ground current: 18 $\mu\text{A}$
- Low dropout voltage: 300mV at 150mA
- High initial output accuracy:  $\pm 1.0\%$
- Stable with ceramic or tantalum capacitors
- Excellent line and load regulation specifications
- Reverse battery protection
- Reverse leakage protection
- Thermal shutdown and current limit protection
- PowerTO-252-5 (D-Pak) package
- Adjustable output from 1.24V-20V

#### Applications

- USB power supply
- Cellular phones
- Keep-alive supply in notebook and portable computers
- Logic supply for high-voltage batteries
- Automotive electronics
- Battery powered systems

#### Typical Application

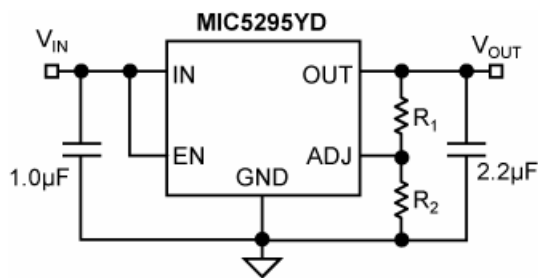

Low Current Adjustable Regulator Application

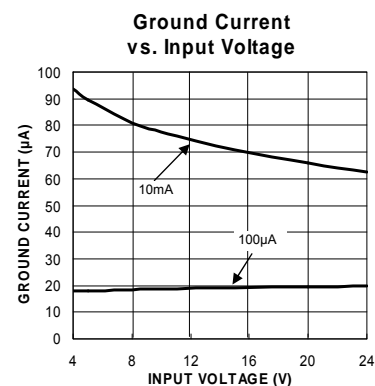

Ground Current vs. Input Voltage

## Ordering Information

Part Number	Marking Code	Voltage	Junction Temp. Range	Package
MIC5295-3.0YD	5295-30Y	3.0V	-40° to +125°C	5-Pin TO-252
MIC5295-3.3YD	5295-33Y	3.3V	-40° to +125°C	5-Pin TO-252
MIC5295-5.0YD	5295-50Y	5.0V	-40° to +125°C	5-Pin TO-252
MIC5295YD	5295YD	Adj	-40° to +125°C	5-Pin TO-252

## Pin Configuration

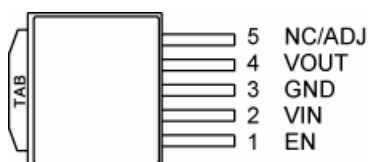

5-Pin TO-252

## Pin Description

Pin Number	Pin Name	Pin Function
1	EN	Enable (Input): Logic low = shutdown; logic high = enable. Do not leave floating.
2	VIN	Supply Input.
3	GND	Ground.
4	VOUT	Regulator Output.
5	NC(fixed)	No Connect.
	ADJ(adj)	Adjust (Input): Feedback input. Connect to resistive Voltage-divider network.

**Absolute Maximum Ratings<sup>(1)</sup>**

Input Supply Voltage .....	-20V to 38V
Enable Input Voltage.....	-0.3V to 38V
Power Dissipation .....	Internally Limited
Junction Temperature .....	-40°C to +125°C
Storage Temperature .....	-65°C to +150°C
ESD Rating <sup>(3)</sup> .....	ESD Sensitive

**Operating Ratings<sup>(2)</sup>**

Input Supply Voltage .....	2.3V to 24V
Enable Input Voltage.....	0V to 24V
Junction Thermal.....	-40°C to +125°C
Package Thermal Resistance TO-252-5 ( $\theta_{JA}$ ) .....	50°C/W

**Electrical Characteristics<sup>(4)</sup>**

$V_{IN} = V_{OUT} + 1V$ ;  $I_{OUT} = 100\mu A$ ;  $C_{IN} = 1.0\mu F$ ,  $C_{OUT} = 2.2\mu A$ ;  $T_J = 25^\circ C$ , **bold** values indicate  $-40^\circ C < T_J < +125^\circ C$ ; unless otherwise specified.

Parameter	Condition	Min	Typ	Max	Units
Output Voltage Accuracy	Variation from nominal $V_{OUT}$	-1.0 <b>-2.0</b>		+1.0 <b>+2.0</b>	% %
Line Regulation	$V_{IN} = V_{OUT} + 1V$ to 24V		0.04		%
Load Regulation	Load = 100 $\mu A$ to 150mA		0.25	1	%
Dropout Voltage	$I_{OUT} = 100\mu A$		45		mV
	$I_{OUT} = 50mA$		220	<b>400</b>	mV
	$I_{OUT} = 100mA$		260	<b>450</b>	mV
	$I_{OUT} = 150mA$		300	<b>500</b>	mV
Reference Voltage			1.24		V
		-1.0		+1.0	%
Ground Current	$I_{OUT} = 100\mu A$		18	30	$\mu A$
	$I_{OUT} = 50mA$		0.35	<b>35</b>	$\mu A$
	$I_{OUT} = 100mA$		1	2	mA
	$I_{OUT} = 150mA$		2	4	mA
Ground Current in Shutdown	$V_{EN} = 0V$ ; $V_{IN} = 24V$		0.1	1	$\mu A$
Current Limit	$V_{OUT} = 0V$		350	500	mA
Ripple Rejection	$f = 1kHz$		50		dB
Output Voltage Noise	10Hz to 100kHz		47		$\mu V_{RMS}$
Output Leakage, Reverse Polarity Input	Load = 500 $\Omega$ ; $V_{IN} = -15V$ ; $V_{EN} = 0.4V$		-0.1		$\mu A$

**Enable Input**

Enable turn on time			1.2	10	ms
Input Low Voltage	Regulator OFF			<b>0.4</b>	V
Input High Voltage	Regulator ON	<b>2.0</b>			V
Enable Input Current	$V_{EN} = 0.6V$ ; Regulator OFF	-1.0	0.01	1.0	$\mu A$
	$V_{EN} = 2.0V$ ; Regulator ON		0.1	1.0	$\mu A$
	$V_{EN} = 24V$ ; Regulator ON		0.5	2.5	$\mu A$

**Notes:**

- Exceeding the absolute maximum rating may damage the device.
- The device is not guaranteed to function outside its operating rating.
- Devices are ESD sensitive. Handling precautions recommended. Human body model, 1.5k $\Omega$  in series with 100pF.
- Specification for packaged product only.

# Typical Characteristics

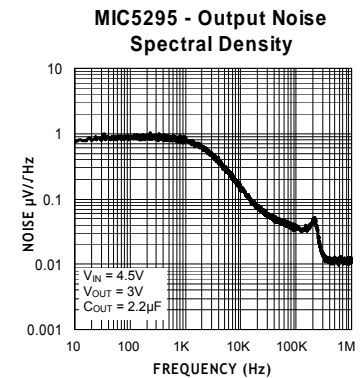
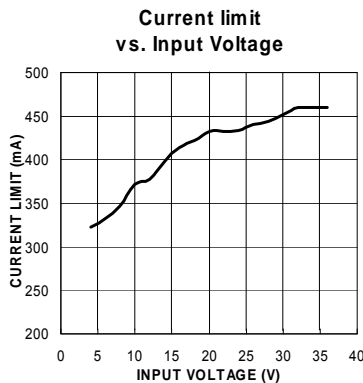
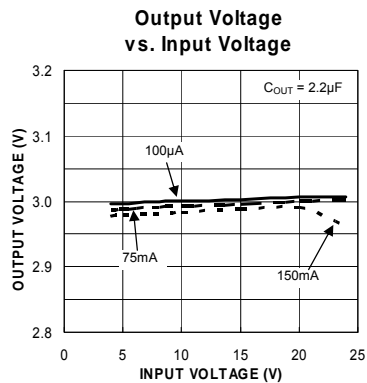
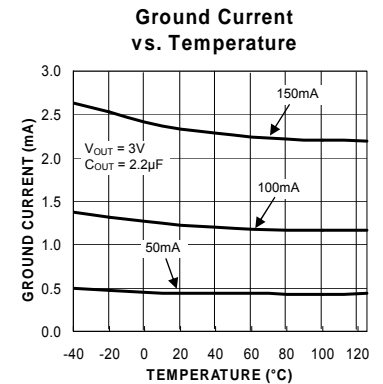
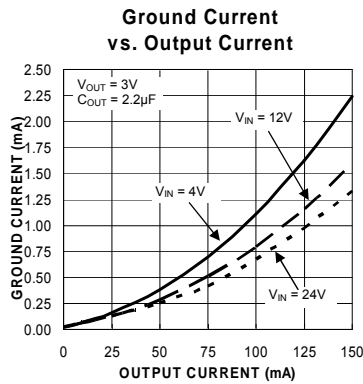
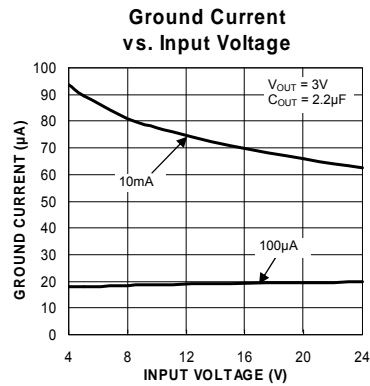
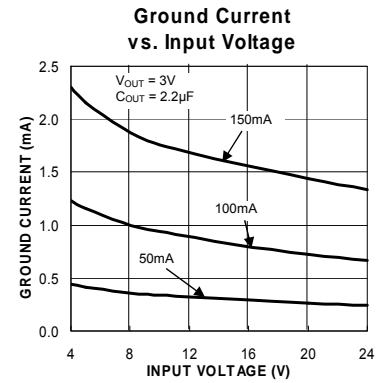
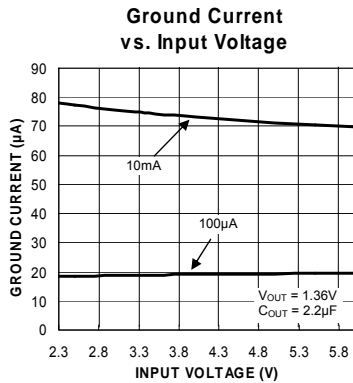
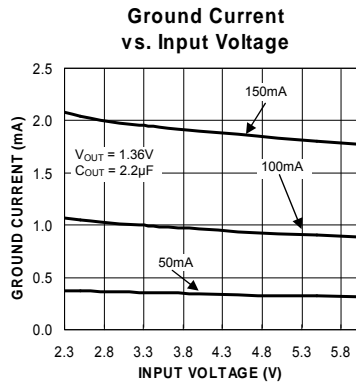
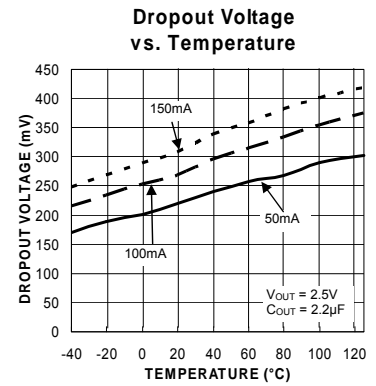
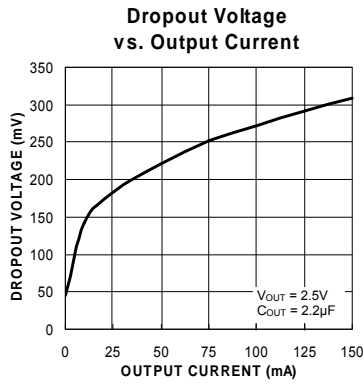
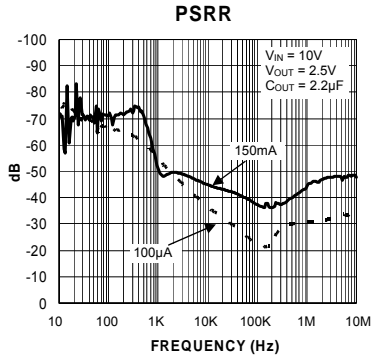

### Typical Characteristics (continued)

**Reverse Current  
(Open Input)**

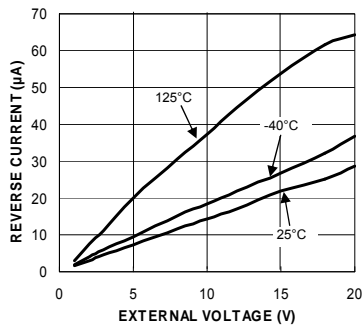

**Reverse Current  
(VIN Grounded)**

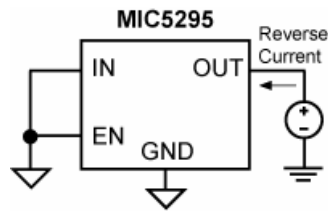
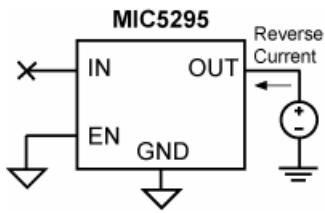
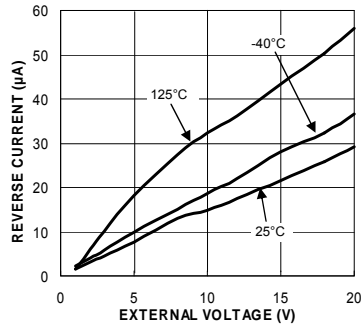

# Functional Characteristics

### Load Transient

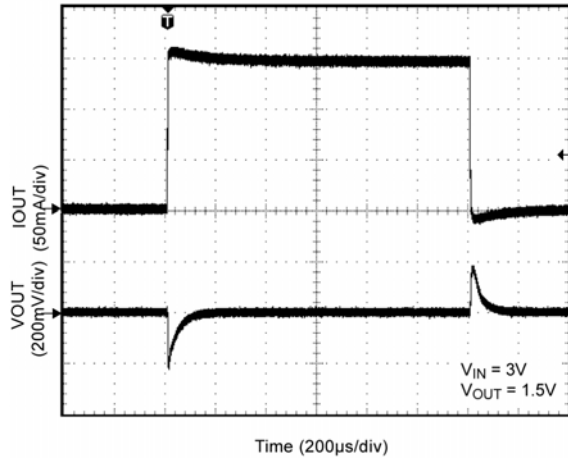

### Line Transient

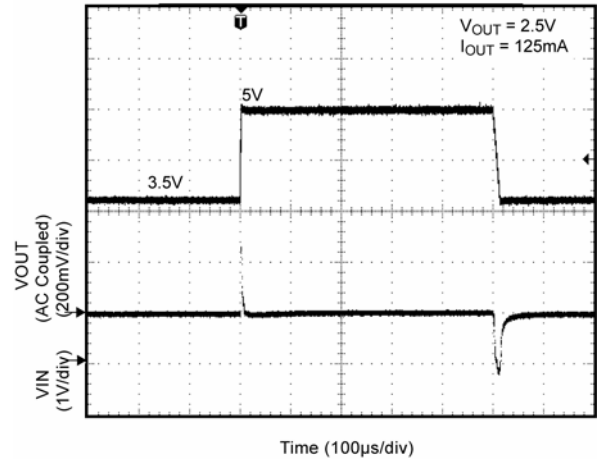

### Turn-On Time

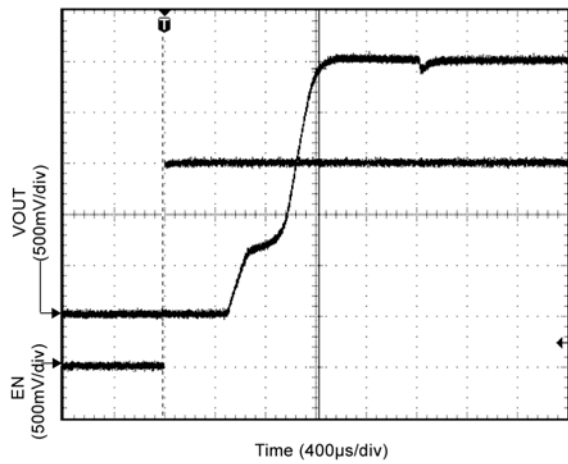

## Functional Diagram

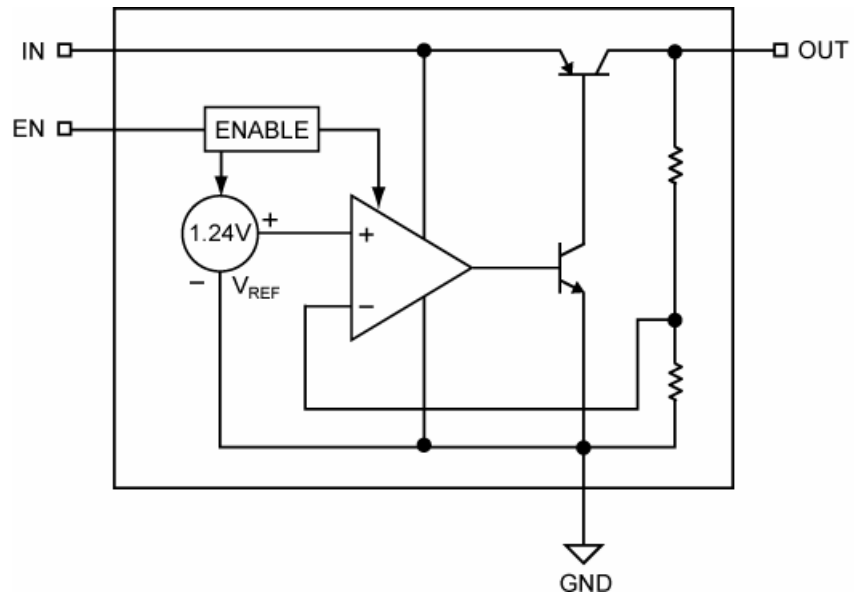

Block Diagram – Fixed Output Voltage

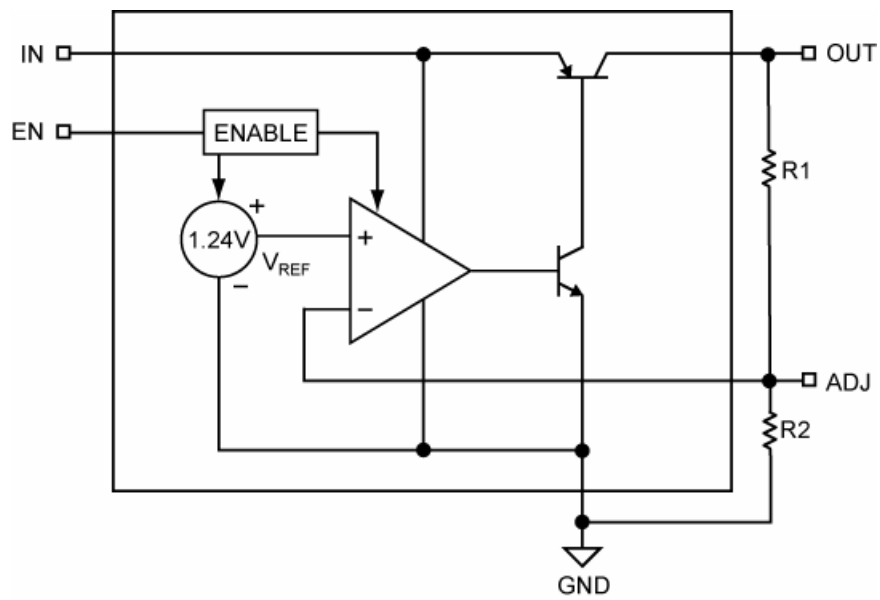

Block Diagram – Adjustable Output Voltage

## Application Information

### Enable/Shutdown

The MIC5295 comes with an active-high enable pin that allows the regulator to be disabled. Forcing the enable pin low disables the regulator and sends it into a “zero” off-mode-current state. In this state, current consumed by the regulator goes nearly to zero. Forcing the enable pin high enables the output voltage. Do not leave this pin floating as the output will be in indeterminate state.

### Input Capacitor

The MIC5295 has high input voltage capability up to 24V. The input capacitor must be rated to sustain voltages that may be used on the input. An input capacitor may be required when the device is not near the source power supply or when supplied by a battery. Small, surface mount, ceramic capacitors can be used for bypassing. Larger values may be required if the source supply has high ripple.

### Output Capacitor

The MIC5295 requires an output capacitor for stability. The design requires 2.2 $\mu$ F or greater on the output to maintain stability. The design is optimized for use with low-ESR ceramic chip capacitors. High ESR capacitors may cause high frequency oscillation. The maximum recommended ESR is 3 $\Omega$ . The output capacitor can be increased without limit. Larger valued capacitors help to improve transient response.

X7R/X5R dielectric-type ceramic capacitors are recommended because of their temperature performance. X7R-type capacitors change capacitance by 15% over their operating temperature range and are the most stable type of ceramic capacitors. Z5U and Y5V dielectric capacitors change value by as much as 50% and 60% respectively over their operating temperature ranges. To use a ceramic chip capacitor with Y5V dielectric, the value must be much higher than a X7R ceramic capacitor to ensure the same minimum capacitance over the equivalent operating temperature range.

### No-Load Stability

The MIC5295 will remain stable with no load unlike many other voltage regulators. This is especially important in CMOS RAM keep-alive applications.

### Thermal Considerations

The MIC5295 is designed to provide 150mA of continuous current in a small package. Maximum ambient operating temperature can be calculated based on the output current and the voltage drop across the

part. For example, given that the input voltage of 3.3V the output voltage is 2.3V and the output current = 150mA. The actual power dissipation of the regulator circuit can be determined using the equation:

$$P_D = (V_{IN} - V_{OUT})I_{OUT} + V_{IN} \times I_{GND}$$

Due to the potential for input voltages up to 24V, ground current must be taken into consideration.

$$P_{D(MAX)} = (3.3 - 2.3V)150mA + 3.3 \times 1.2mA$$

$$P_{D(MAX)} = 0.154W$$

The junction-to-ambient thermal resistance for the MIC5295, D-Pak is 50°C/W. To determine the maximum ambient operating temperature of the package, use the junction-to-ambient thermal resistance of the device and the following basic equation:

$$P_{D(MAX)} = \left( \frac{T_{J(MAX)} - T_A}{\theta_{JA}} \right)$$

$T_{J(MAX)}$  is the maximum junction temperature of the die, 125°C, the maximum ambient temperature can be calculated to be 117.3°C as shown below:

$$0.154W = \left( \frac{125^\circ C - T_A}{50^\circ C/W} \right)$$

$$T_A = 117.3^\circ C$$

### Adjustable Regulator Application

The MIC5295YD can be adjusted from 1.24V to 20V by using two external resistors (Figure 1). The resistors set the output voltage based on the following equation:

$$V_{OUT} = V_{REF} \left( 1 + \left( \frac{R_1}{R_2} \right) \right)$$

Where  $V_{REF} = 1.24V$ .

Feedback resistor R2 should be no larger than 300k $\Omega$ .

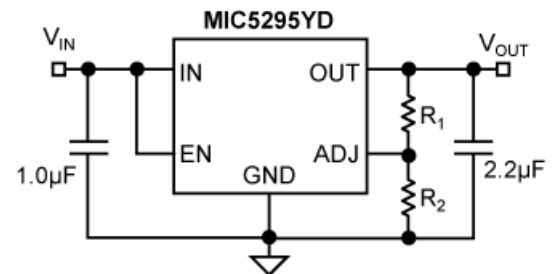
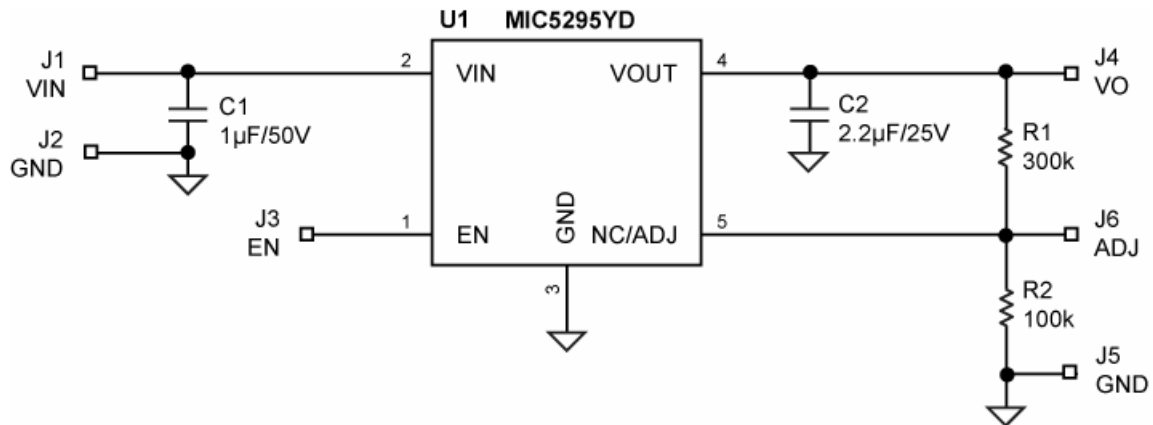

Figure 1. Adjustable Voltage Application



## Evaluation Board Schematic



## Bill of Materials

Item	Part Number	Manufacturer	Description	Qty.
C1	UMK325BJ105KM-T	Taiyo Yuden <sup>(1)</sup>	Capacitor, 1µF, 50V, X5R, Size 1210	1
C2	TMK212BJ225KG-T	Taiyo Yuden	Capacitor, 2.2µF, 25V, X5R, Size 0805	1
R1	CRCW06033003FKEYE3	Vishay Dale <sup>(2)</sup>	Resistor, 300k, 1%. 1/16W, Size 0603	1
R2	CRCW06031003FKEYE2	Vishay Dale	Resistor, 100k, 1%. 1/16W, Size 0603	1
U1	MIC5295YD	Micrel, Inc. <sup>(3)</sup>	Low Quiescent Current, 150mA LDO Regulator	1

**Notes:**

1. Murata: [www.t-yuden.com](http://www.t-yuden.com)
2. Vishay: [www.vishay.com](http://www.vishay.com).
3. **Micrel, Inc.:** [www.micrel.com](http://www.micrel.com).

### PCB Layout Recommendations

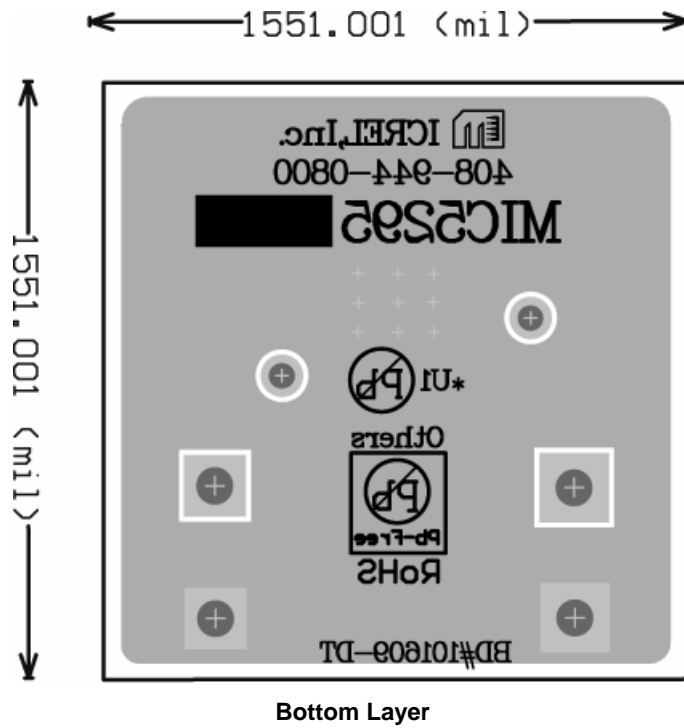
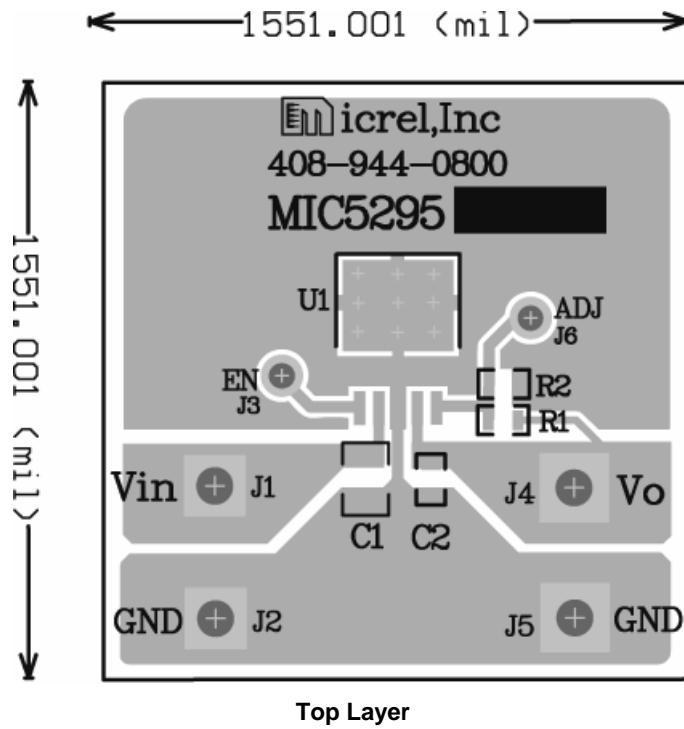

# Package Information

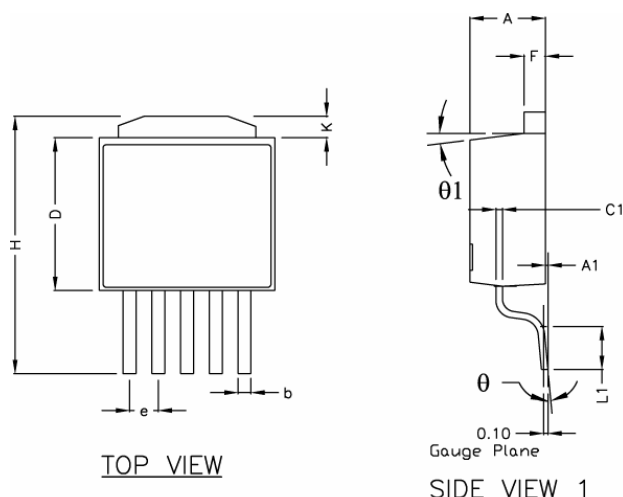

POS	INCH		MM	
	MIN	MAX	MIN	MAX
A	0.087	0.094	2.210	2.387
A1	0.000	0.012	0.000	0.305
b	0.023	0.026	0.584	0.660
C1	0.012	0.023	0.305	0.584
D	0.236	0.241	6.000	6.200
E	0.252	0.260	6.400	6.604
e	0.045	0.055	1.143	1.397
F	0.019	0.023	0.483	0.584
H	0.378	0.402	9.601	10.210
K	0.039	0.047	1.000	1.200
L1	0.055	0.065	1.397	1.651
$\theta$	0°	8°	0°	8°
$\theta 1$	3°	10°	3°	10°
Q	0.055	0.075	1.397	1.905
U	0.206	Ref.	5.232	Ref.
V	0.213	Ref.	5.415	Ref.

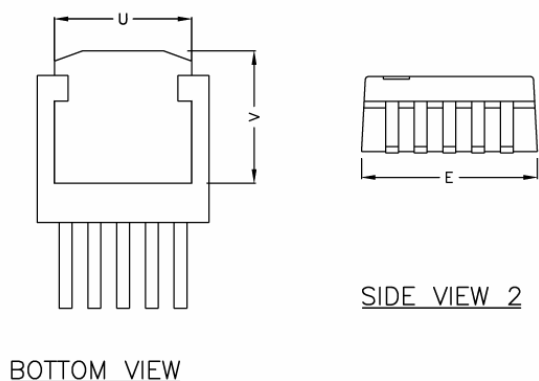

- NOTE:
1. PACKAGE OUTLINE EXCLUSIVE OF MOLD FLASH & METAL BURR.
  2. PACKAGE OUTLINE INCLUSIVE OF PLATING THICKNESS.
  3. FOOT LENGTH USING GAUGE PLANE METHOD MEASUREMENT 0.010"
  4. ALL DIMENSIONS ARE IN INCHES/MILLIMETERS.

## 5-Pin TO-252

**MICREL, INC. 2180 FORTUNE DRIVE SAN JOSE, CA 95131 USA**  
 TEL +1 (408) 944-0800 FAX +1 (408) 474-1000 WEB <http://www.micrel.com>

The information furnished by Micrel in this data sheet is believed to be accurate and reliable. However, no responsibility is assumed by Micrel for its use. Micrel reserves the right to change circuitry and specifications at any time without notification to the customer.

Micrel Products are not designed or authorized for use as components in life support appliances, devices or systems where malfunction of a product can reasonably be expected to result in personal injury. Life support devices or systems are devices or systems that (a) are intended for surgical implant into the body or (b) support or sustain life, and whose failure to perform can be reasonably expected to result in a significant injury to the user. A Purchaser's use or sale of Micrel Products for use in life support appliances, devices or systems is a Purchaser's own risk and Purchaser agrees to fully indemnify Micrel for any damages resulting from such use or sale.

© 2009 Micrel, Incorporated.