

General Description

The MIC4575 is a series of easy to use fixed and adjustable BiCMOS step-down (buck) switch-mode voltage regulators. The 200kHz MIC4575 duplicates the pinout and function of the 52kHz LM2575. The higher switching frequency may allow up to a 2:1 reduction in output filter inductor size.

The MIC4575 is available in 3.3V, and 5V fixed output versions or a 1.23V to 20V adjustable output version. Both versions are capable of driving a 1A load with excellent line and load regulation.

The feedback voltage is guaranteed to $\pm 2\%$ tolerance for adjustable versions, and the output voltage is guaranteed to $\pm 3\%$ for fixed versions, within specified voltages and load conditions. The oscillator frequency is guaranteed to $\pm 10\%$.

In shutdown mode, the regulator draws less than 200 μ A standby current. The regulator performs cycle-by-cycle current limiting and thermal shutdown for protection under fault conditions.

This series of simple switch-mode regulators requires a minimum number of external components and can operate using a standard series of inductors. Frequency compensation is provided internally.

The MIC4575 is available in TO-220 (T) and TO-263 (U) packages for the industrial temperature range.

Data sheets and support documentation can be found on Micrel's web site at www.micrel.com.

Features

- Fixed 200kHz operation
- 3.3V, 5V, and adjustable output versions
- Voltage over specified line and load conditions:
- Fixed version: $\pm 3\%$ max. output voltage
- Adjustable version: $\pm 2\%$ max. feedback voltage
- Guaranteed 1A switch current
- Wide 4V to 24V input voltage range
- Wide 1.23V to 20V output voltage range
- Requires minimum external components
- < 200 μ A typical shutdown mode
- 75% efficiency (adjustable version > 75% typical)
- Standard inductors and capacitors are 25% of typical LM2575 values
- Thermal shutdown
- Overcurrent protection
- 100% electrical thermal limit burn-in

Applications

- Simple high-efficiency step-down (buck) regulator
- Efficient pre-regulator for linear regulators
- On-card switching regulators
- Positive-to-negative converter (inverting buck-boost)
- Battery charger
- Negative boost converter
- Step-down 6V to 3.3V for Intel Pentium[®] and similar microprocessors

Typical Application

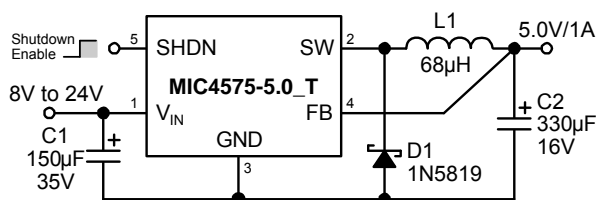

Fixed Regulator

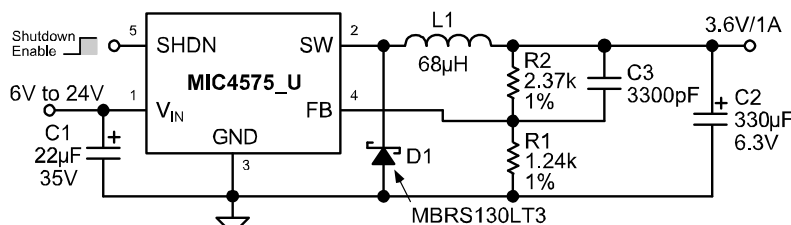

Adjustable Regulator

Pentium is a registered trademark of Intel Corporation

Micrel Inc. • 2180 Fortune Drive • San Jose, CA 95131 • USA • tel +1 (408) 944-0800 • fax + 1 (408) 474-1000 • <http://www.micrel.com>

Ordering Information

Part Number		Voltage	Temperature Range	Package
Standard	RoHS Compliant*			
MIC4575-3.3BT	MIC4575-3.3WT	3.3V	-40° to +85°C	5-Pin TO-220
MIC4575-5.0BT	MIC4575-5.0WT	5.0V	-40° to +85°C	5-Pin TO-220
MIC4575BT	MIC4575WT	Adj.	-40° to +85°C	5-Pin TO-220
MIC4575-3.3BU	MIC4575-3.3WU	3.3V	-40° to +85°C	5-Pin TO-263
MIC4575-5.0BU	MIC4575-5.0WU	5.0V	-40° to +85°C	5-Pin TO-263
MIC4575BU	MIC4575WU	Adj.	-40° to +85°C	5-Pin TO-263

* RoHS compliant with 'high-melting solder' exemption.

Pin Configuration

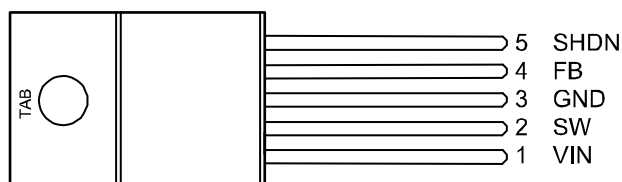

5-Pin TO-220 (T)

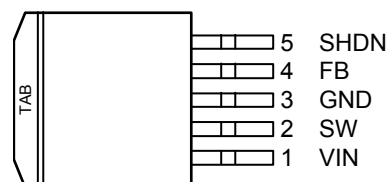

5-Pin TO-263 (U)

Pin Description

Pin Number	Pin Name	Pin Function
1	IN	Supply Voltage (Input): Unregulated +4V to +40V supply voltage.
2	SW	Switch (Output): Emitter of NPN output switch. Connect to external storage inductor and Shottky diode.
3, TAB	GND	Ground.
4	FB	Feedback (Input): Output voltage feedback to regulator. Connect to output of supply for fixed versions. Connect to 1.23V tap of resistive divider for adjustable versions.
5	SHDN	Shutdown (Input): Logic low enables regulator. Logic high (> 2.4V) shuts down regulator.

Absolute Maximum Ratings

Supply Voltage (V_{IN}) ⁽¹⁾	+40V
Shutdown Voltage (V_{SHDN}).....	-0.3V to +36V
Output Switch (V_{SW})	-1V
Storage Temperature (T_s)	-65°C to 150°C
ESD ⁽²⁾	

Operating Ratings

Supply Voltage (V_{IN}).....	+24V
Junction Temperature (T_J)	+150°C
Package Thermal Resistance	
TO-220, TO-263 (θ_{JA})	65°C/W
TO-220, TO-263 (θ_{JC})	2°C/W

Electrical Characteristics⁽⁴⁾

$V_{IN} = 12V$; $I_{LOAD} = 200mA$; $T_J = 25^\circ C$, **bold** values indicate $-40^\circ C \leq T_J \leq +85^\circ C$, unless noted.

Parameter	Condition	Min	Typ	Max	Units
MIC4575 [Adjustable]					
Feedback Voltage		1.217	1.230	1.243	V
Feedback Voltage	$8V \leq V_{IN} \leq 24V$, $0.2A \leq I_{LOAD} \leq 1A$	1.193 1.180	1.230	1.267 1.280	V V
Efficiency	$I_{LOAD} = 1A$, $V_{OUT} = 5V$		77		%
Feedback Bias Current			50	100 500	nA nA
MIC4575-3.3					
Output Voltage		3.234	3.3	3.366	V
Output Voltage	$6V \leq V_{IN} \leq 24V$, $0.2A \leq I_{LOAD} \leq 1A$	3.168 3.135	3.3	3.432 3.465	V V
Efficiency	$I_{LOAD} = 1A$		72		%
MIC4575-5.0					
Output Voltage		4.900	5.0	5.100	V
Output Voltage	$8V \leq V_{IN} \leq 24V$, $0.2A \leq I_{LOAD} \leq 1A$	4.800 4.750	5.0	5.200 5.250	V V
Efficiency	$I_{LOAD} = 1A$		77		%
MIC4575 / -3.3 / -5.0					
Oscillator Frequency		180	200	220	kHz
Saturation Voltage	$I_{OUT} = 1A$		1	1.3 1.5	V V
Maximum Duty Cycle (On)	FB connected to 0V	90	95		%
Current Limit	Peak Current, $t_{ON} \leq 3\mu s$	1.7 1.3	2.2	3.0 3.2	A A
Output Leakage Current	$V_{IN} = 24V$, FB connected to 0V Output = 0V Output = -1V		0 7.5	2 35	mA mA
Quiescent Current			5	10	mA
Standby Quiescent Current	SHDN = 5V (regulator off)		50	200	μA
SHDN Input Logic Level	$V_{OUT} = 0V$ (regulator off)	2.2 2.4	1.4		V V
SHDN Input Current	$V_{OUT} = 3.3$ or $5V$ (regulator on)		1.2	1.0 0.8	V V
	SHDN = 5V (regulator off) SHDN = 0V (regulator on)	-10	4 0.01	30 10	μA μA

Notes:

- The MIC4575 is not guaranteed to survive a short circuit to ground for input voltage above 24V.
- Devices are ESD sensitive. Handling precautions recommended.

Functional Diagram

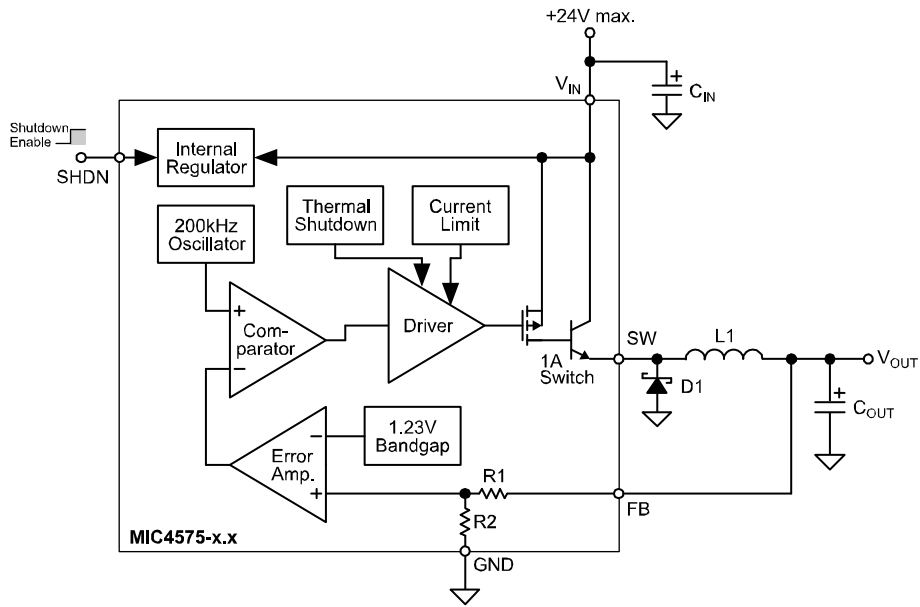

**Block Diagram with External Components
Fixed Step-Down Regulator**

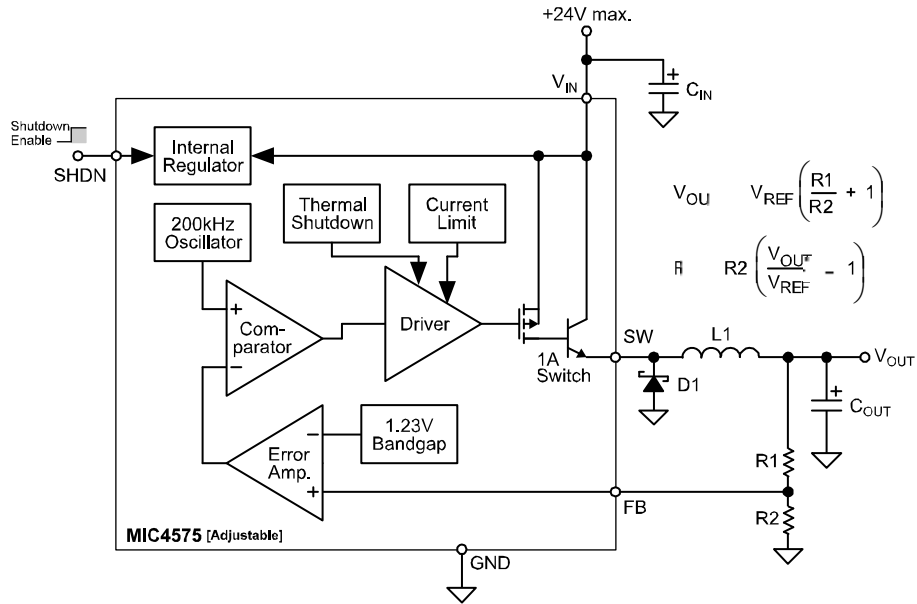

**Block Diagram with External Components
Adjustable Step-Down Regulator**

Functional Description

The MIC4575 is a variable duty cycle switch-mode regulator with an internal power switch. Refer to the block diagrams.

Supply Voltage

The MIC4575 operates from a +4V to +24V unregulated input. Highest efficiency operation is from a supply voltage around +15V.

Enable/Shutdown

The shutdown (SHDN) input is TTL compatible. Ground the input if unused. A logic-low enables the regulator. A logic-high shuts down the internal regulator which reduces the current to typically 50 μ A.

Feedback

Fixed versions of the regulator have an internal resistive divider from the feedback (FB) pin. Connect FB directly to the output line.

Adjustable versions require an external resistive voltage divider from the output voltage to ground, connected from the 1.23V tap to FB.

Duty Cycle Control

A fixed-gain error amplifier compares the feedback signal with a 1.23V bandgap voltage reference. The resulting error amplifier output voltage is compared to a 200kHz sawtooth waveform to produce a voltage controlled variable duty cycle output.

A higher feedback voltage increases the error amplifier output voltage. A higher error amplifier voltage (comparator inverting input) causes the comparator to detect only the peaks of the sawtooth, reducing the duty cycle of the comparator output. A lower feedback voltage increases the duty cycle.

Output Switching

When the internal switch is on, an increasing current flows from the supply V_{IN} , through external storage inductor L1, to output capacitor C_{OUT} and the load. Energy is stored in the inductor as the current increases with time.

When the internal switch is turned off, the collapse of the magnetic field in L1 forces current to flow through fast recovery diode D1, charging C_{OUT} .

Output Capacitor

External output capacitor C_{OUT} provides stabilization and reduces ripple.

Return Paths

During the on portion of the cycle, the output capacitor and load currents return to the supply ground. During the off portion of the cycle, current is being supplied to the output capacitor and load by storage inductor L1, which means that D1 is part of the high-current return path.

Application Information

The applications circuits that follow have been constructed and tested. Refer to *Application Note 15* for additional information, including efficiency graphs and manufacturer's addresses and telephone numbers for most circuits.

For a mathematical approach to component selection and circuit design, refer to *Application Note 14*.

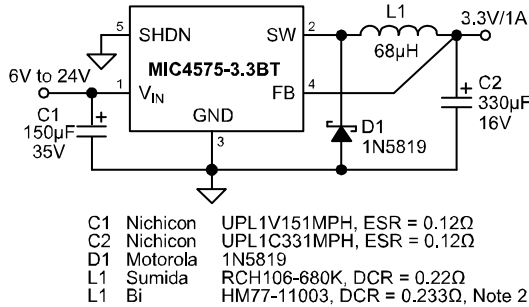

Figure 1. 6V–24V to 3.3V/1A Buck Converter Through Hole

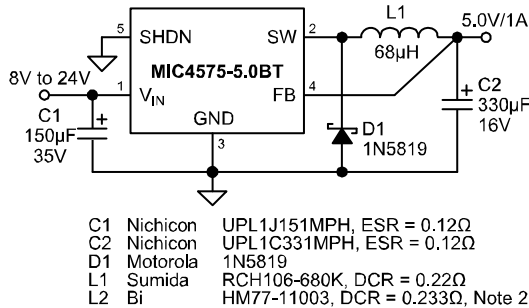

Figure 2. 8V–24V to 5V/1A Buck Converter Through Hole

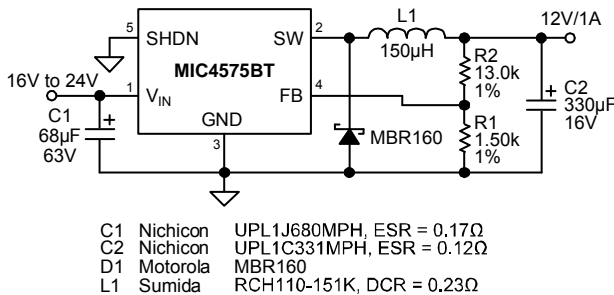

Figure 3. 16V–24V to 12V/1A Buck Converter Through Hole

Note 2: Surface-mount component.

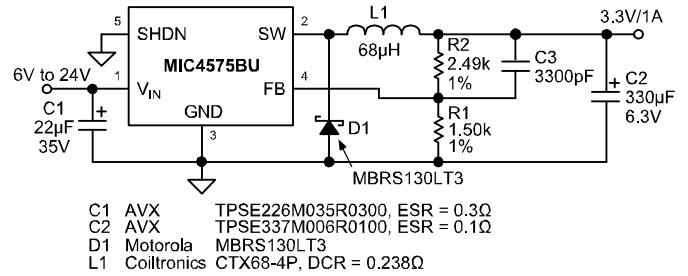

Figure 4. 6V–24V to 3.3V/1A Buck Converter Low-Profile Surface Mount

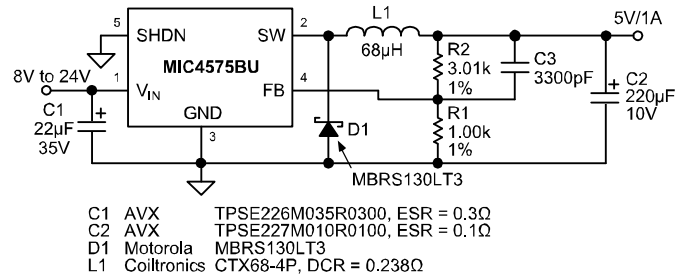

Figure 5. 8V–24V to 5V/1A Buck Converter Low-Profile Surface Mount

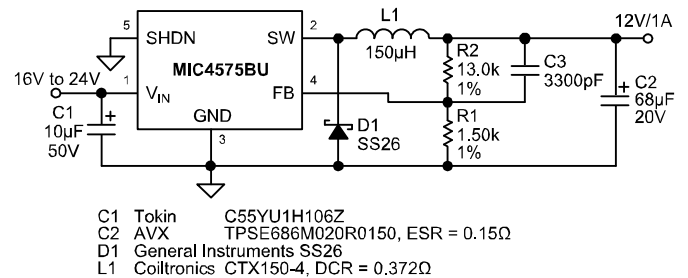

Figure 6. 16V–24V to 12V/1A Buck Converter Low-Profile Surface Mount

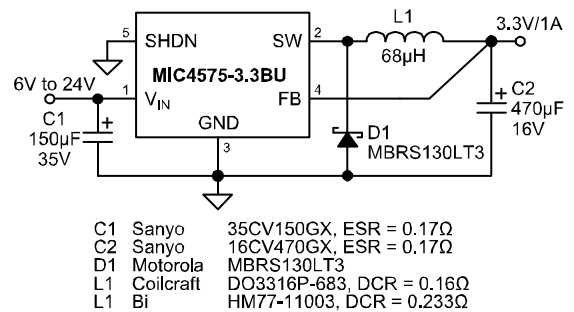

Figure 7. 6V–24V to 3.3V/1A Buck Converter Lower-Cost Surface Mount

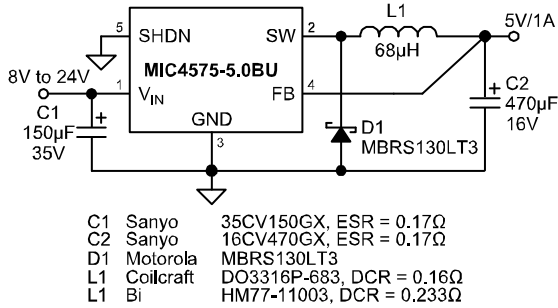

Figure 8. 8V–24V to 5V/1A Buck Converter Lower-Cost Surface Mount

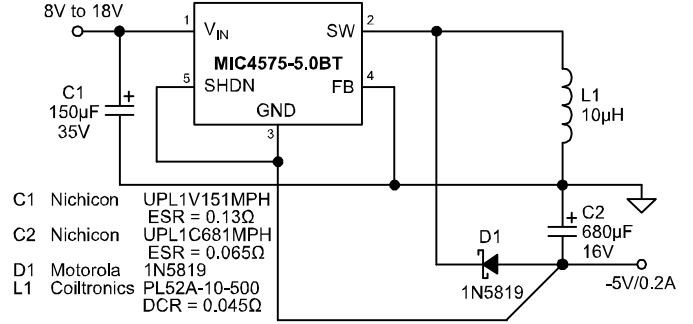

Figure 10. 8V–18V to –5V/0.2A Buck-Boost Converter Through Hole

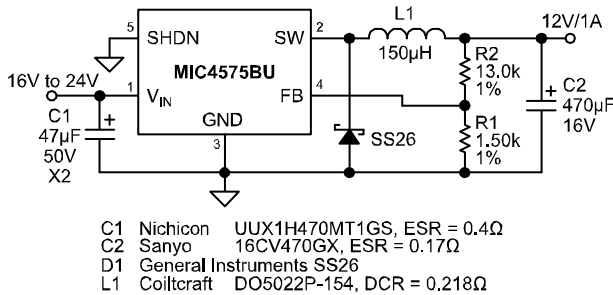

Figure 9. 16V–24V to 12V/1A Buck Converter Lower-Cost Surface Mount

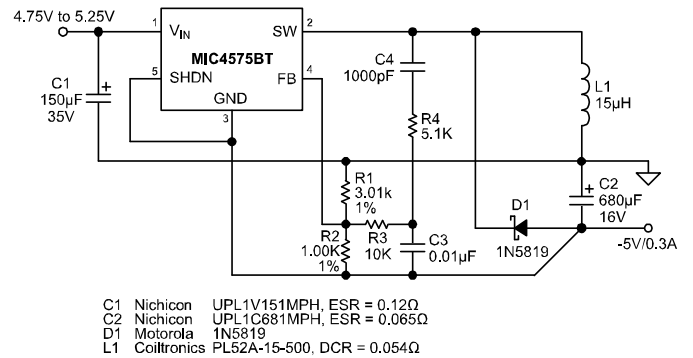

Figure 11. 5V to –5V/0.3A Buck-Boost Converter Through Hole

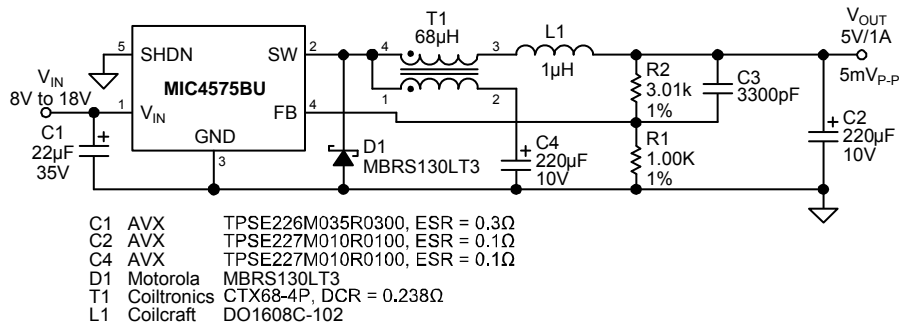

Figure 12. Low Output-Noise Regulator (5mV Output Ripple)

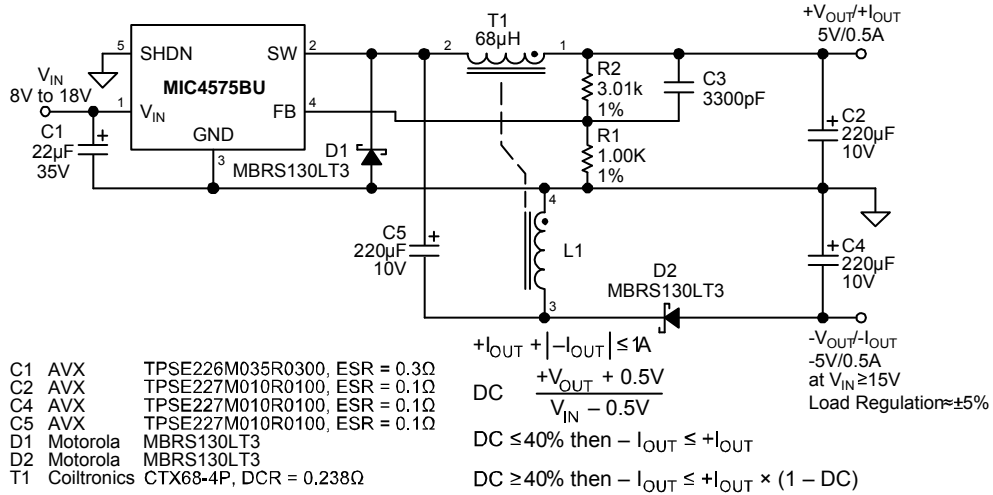

Figure 13. Split ±5V Supply

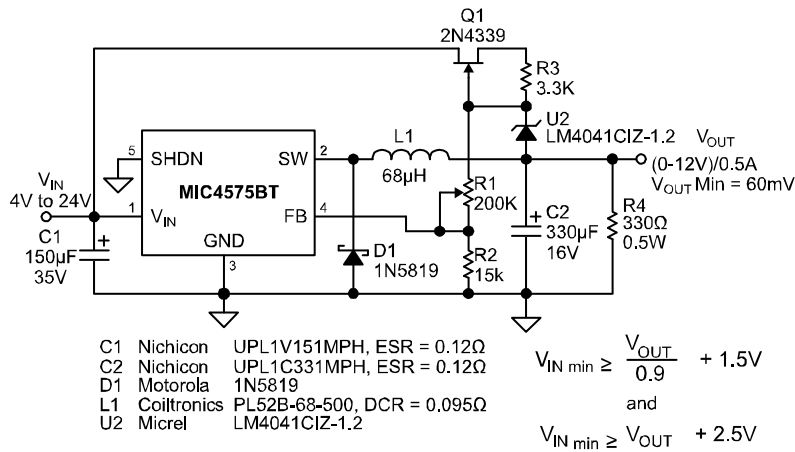

Figure 14. Adjustable (0V-12V) Output-Voltage Regulator

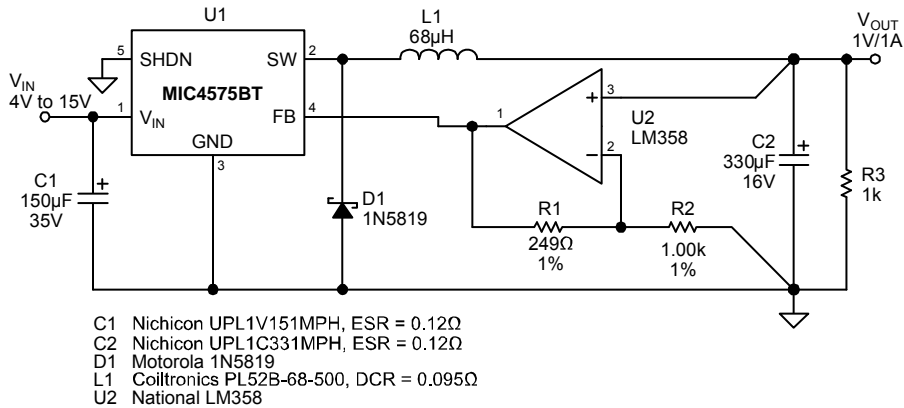

Figure 15. Low Output-Voltage Regulator (1V)

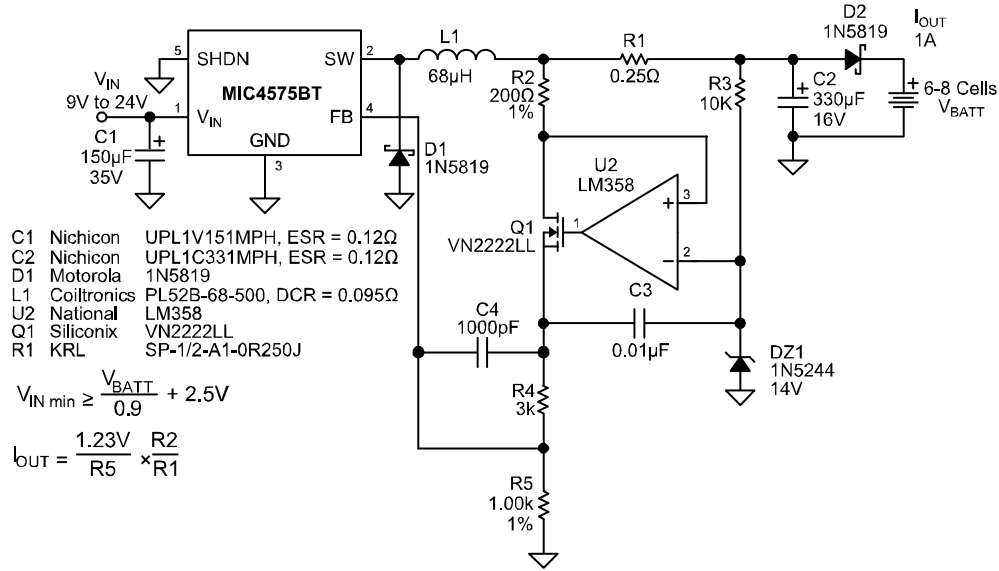

Figure 16. 1A Battery Charger (6–8 cells)

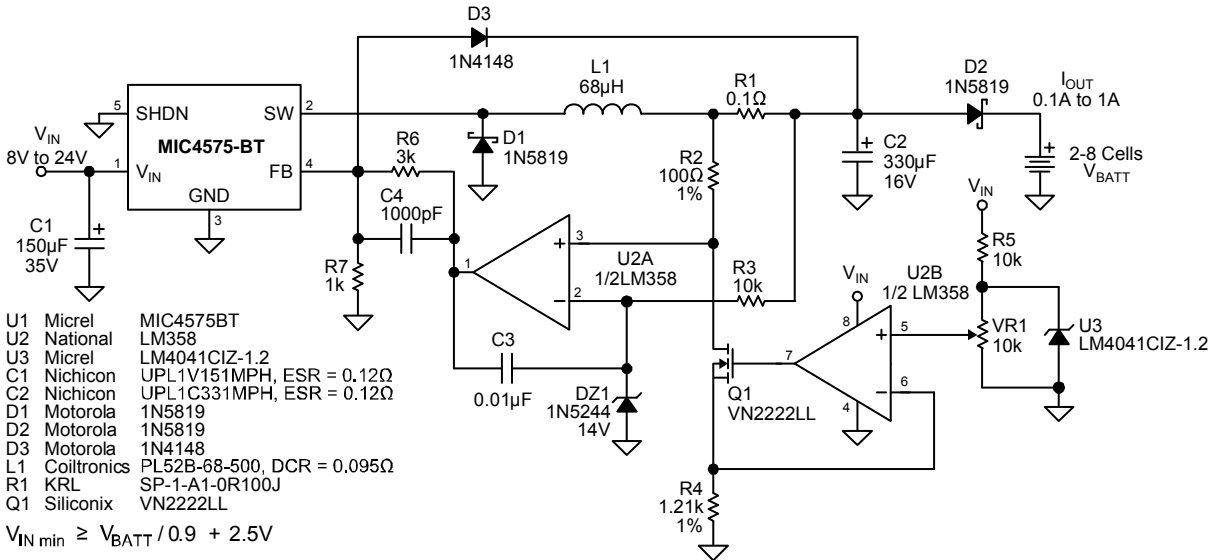

Figure 17. 0.1A–1A Variable-Current Battery Charger

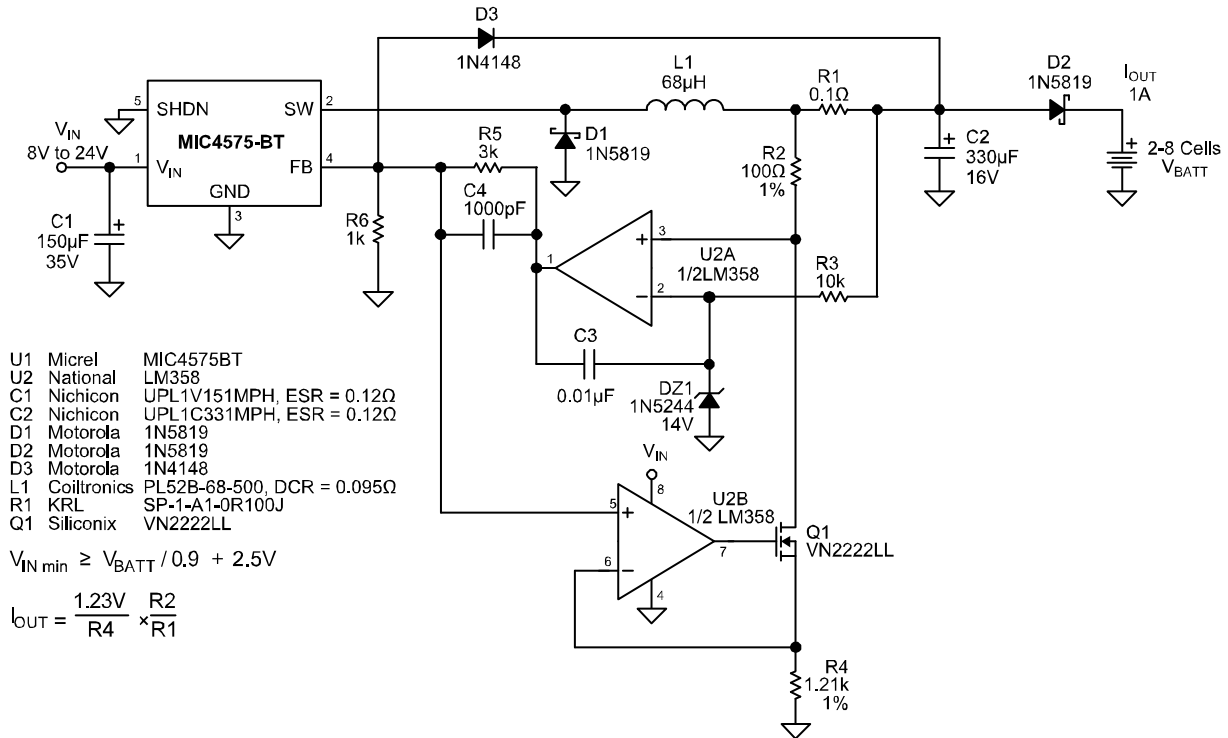

Figure 18. 1A Battery Charger (2-8 Cells)

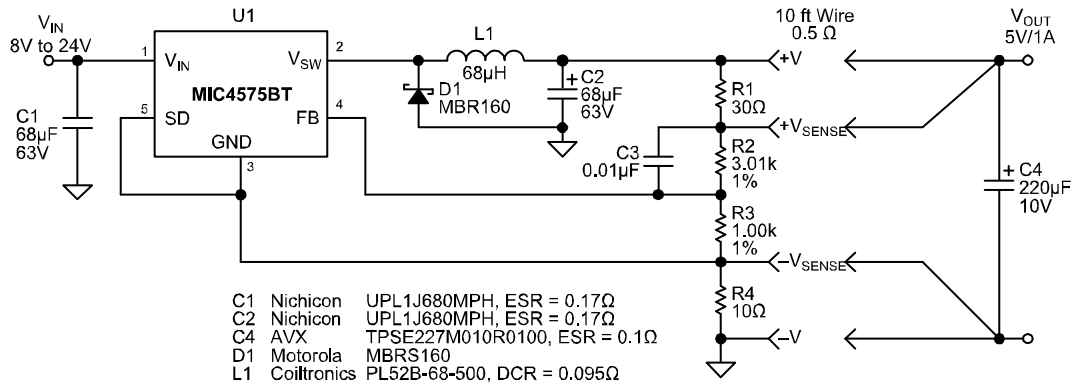

Figure 19. Remote-Sensing Regulator

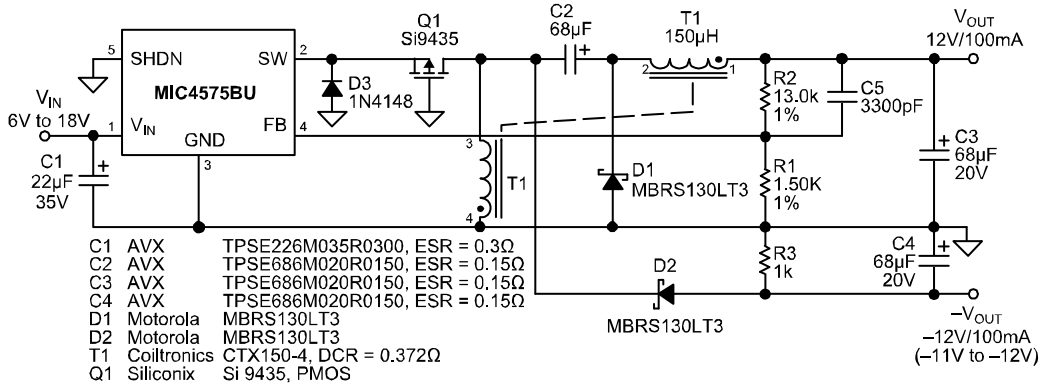

Figure 20. 6V–18V to Split ±12V/100mA Supply

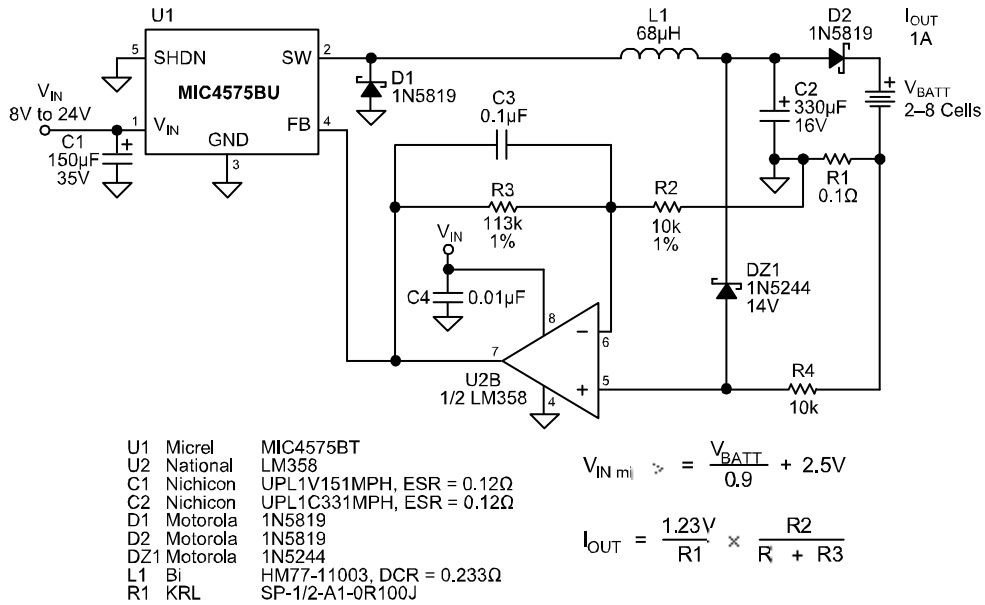

Figure 21. 1A Battery Charger

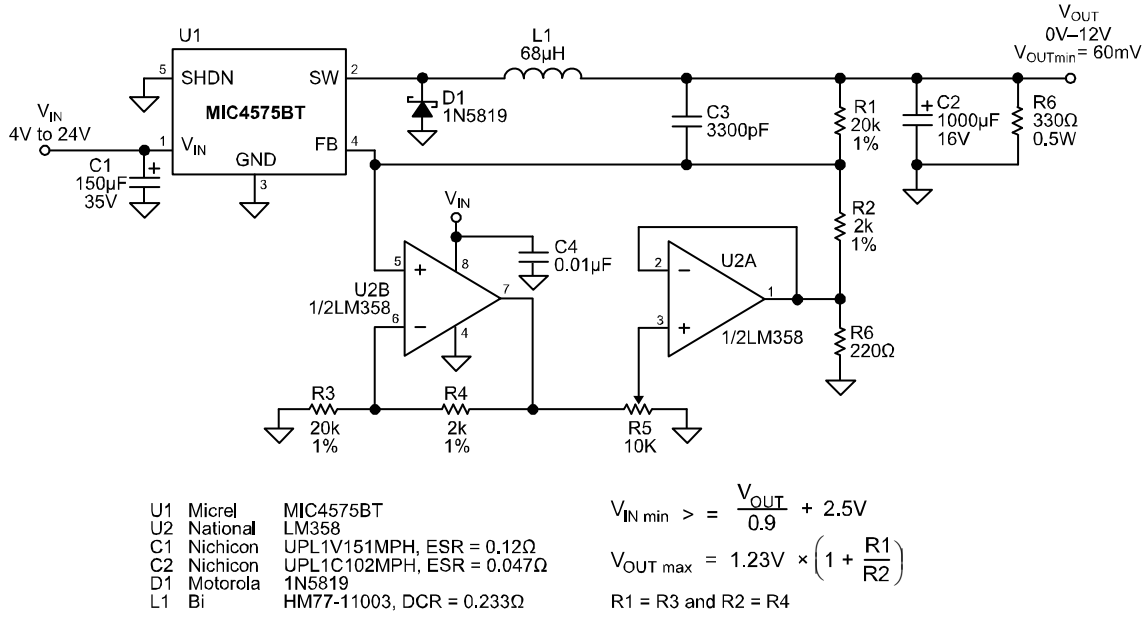

Figure 22. Improved Adjustable Output-Voltage Regulator (0V-12V)

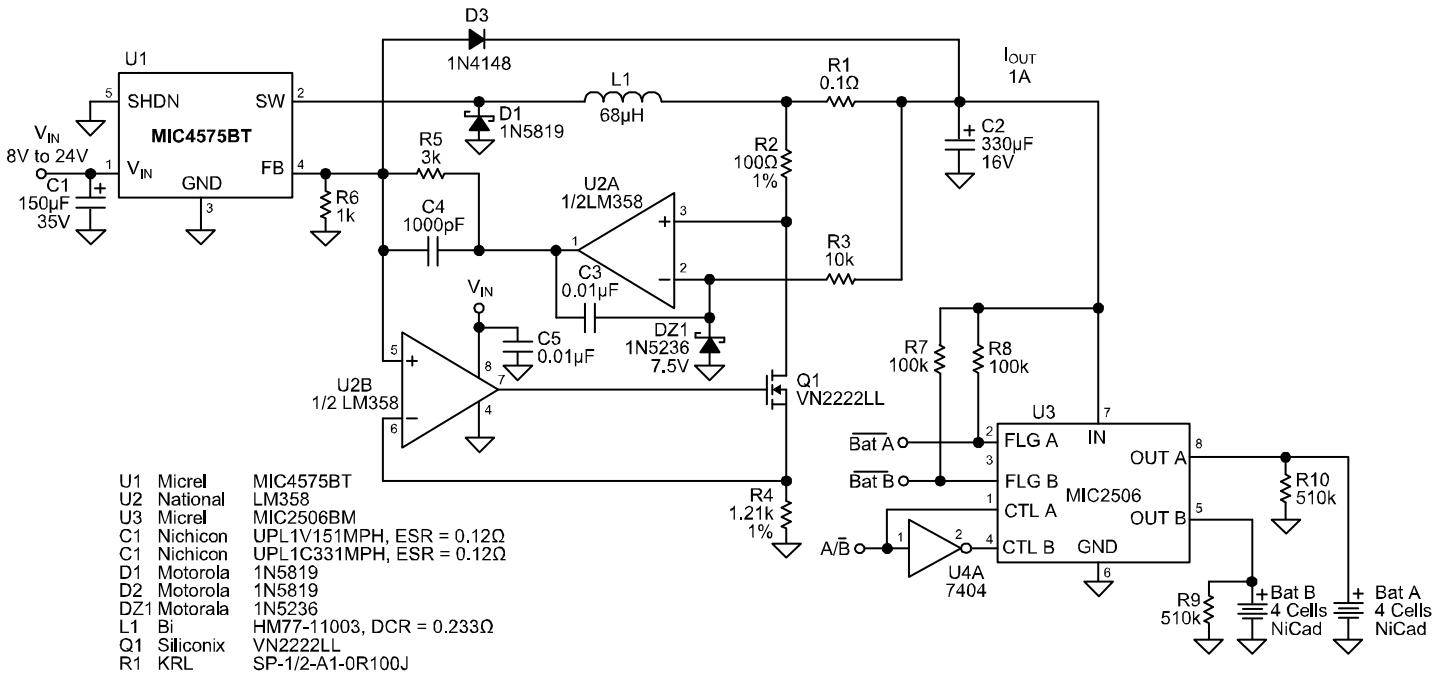

Figure 23. Switchable Battery-Pack Charger

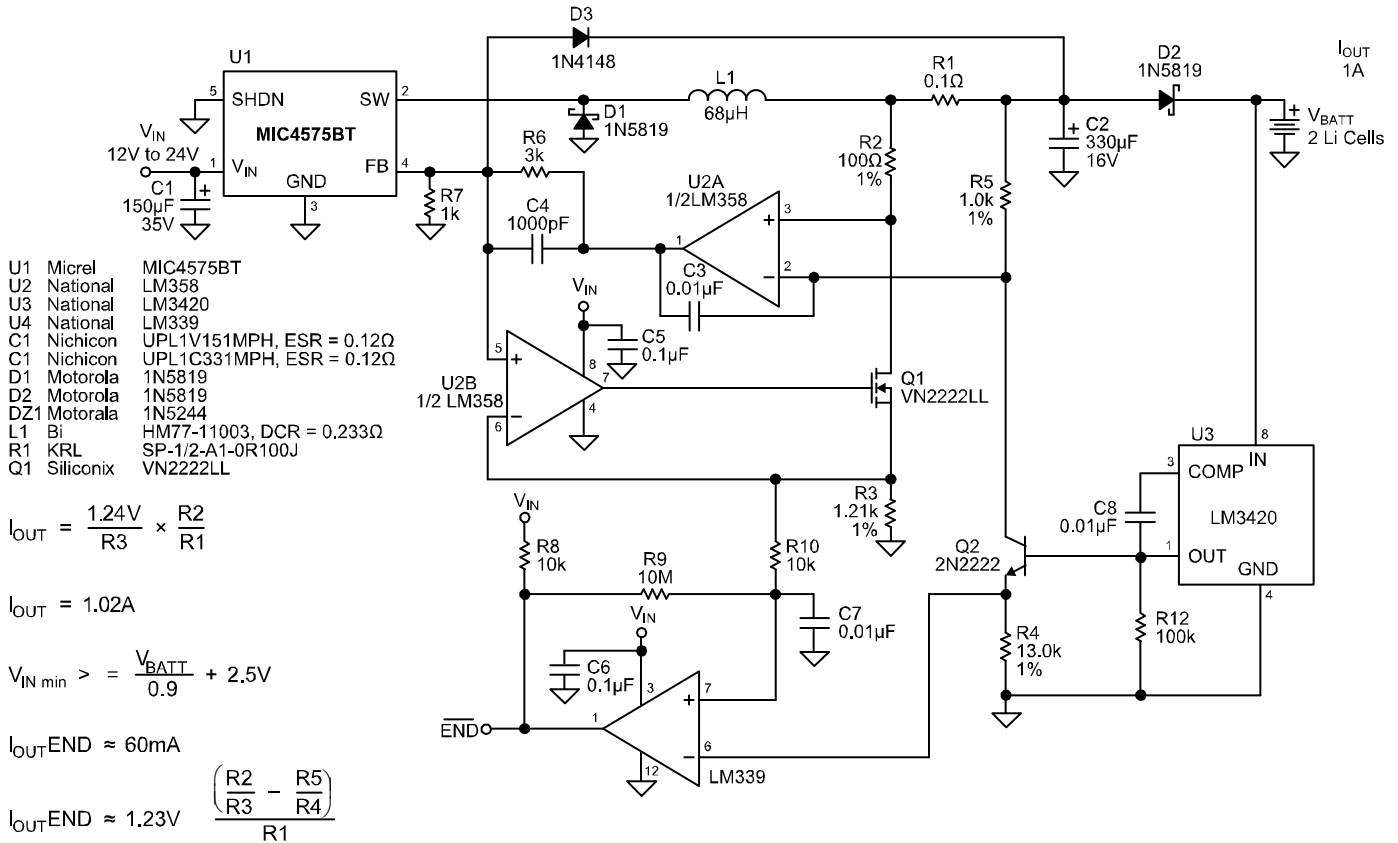

Figure 24. Lithium-Ion Battery Charger with End-of-Charge Flag

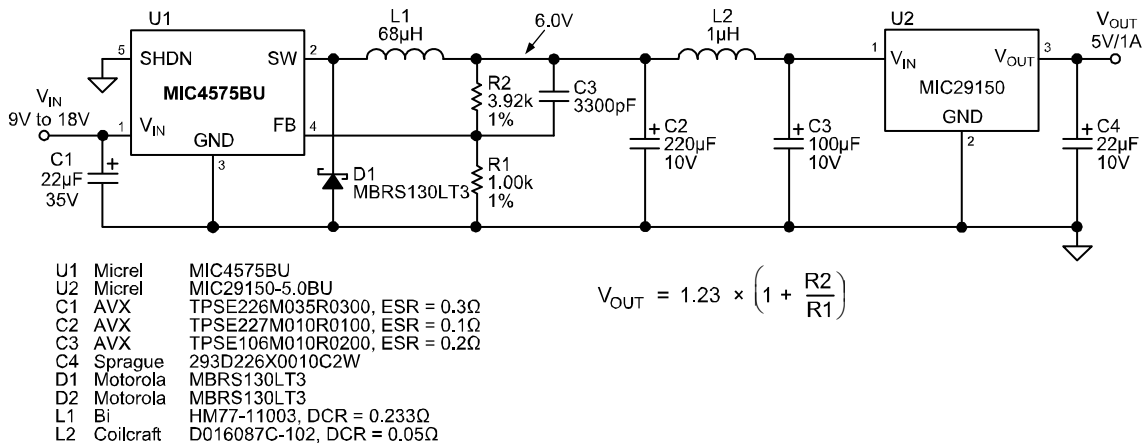
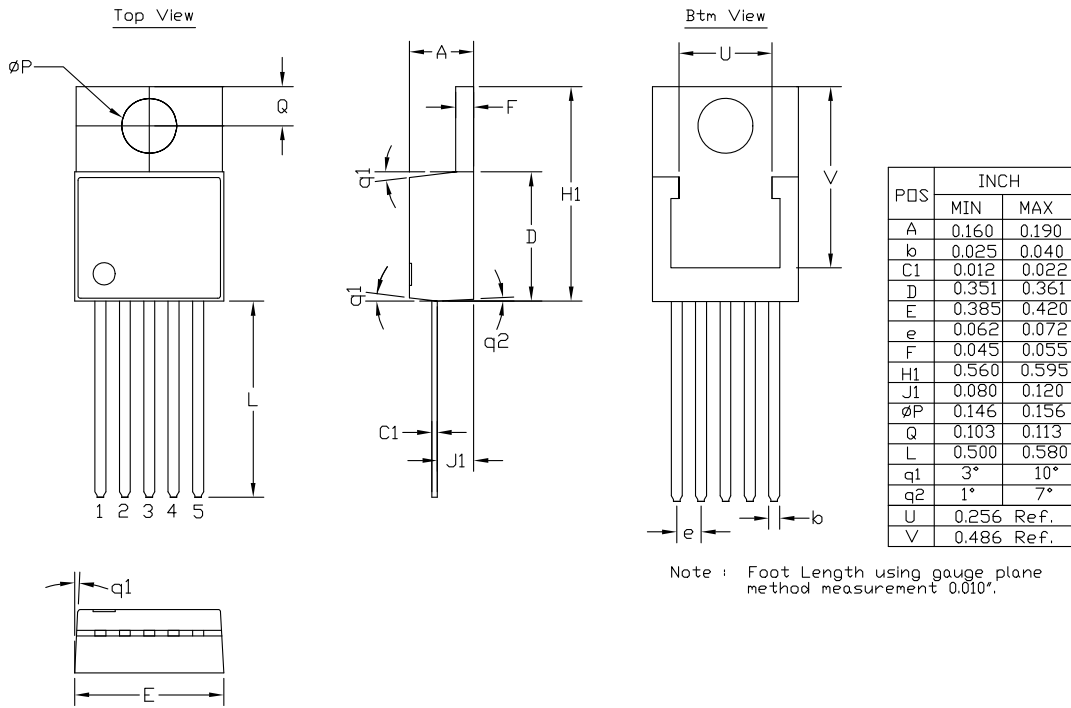
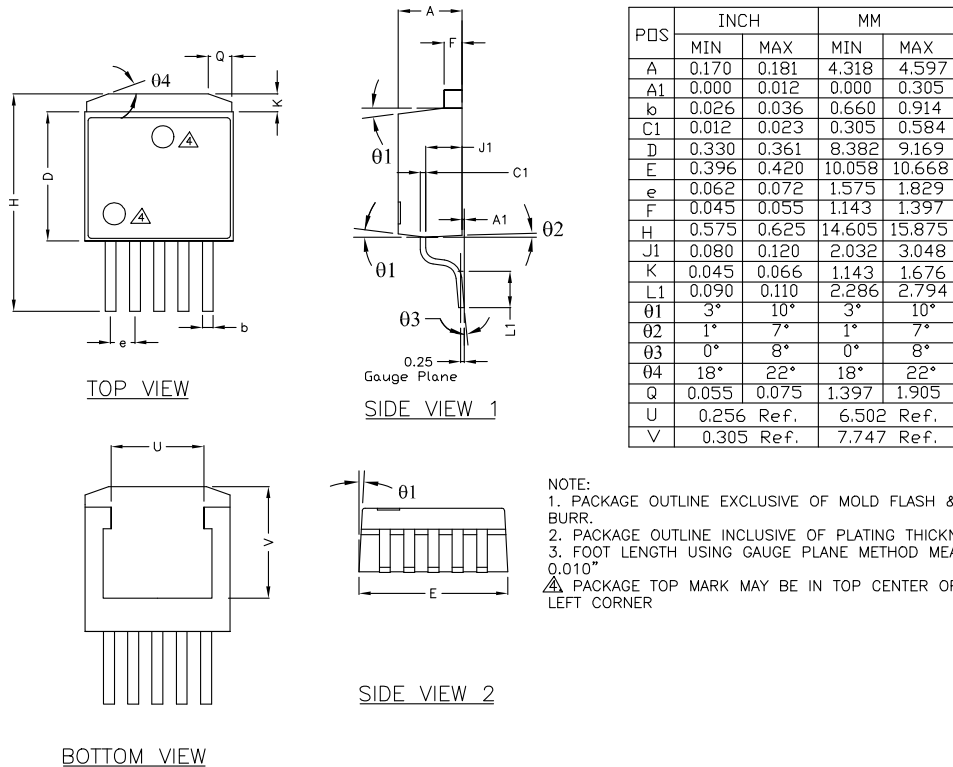

Figure 25. Low Output-Noise Regulator (<1mV)

Package Information



5-Pin TO-220 (T)



5-Pin TO-263 (U)

MICREL, INC. 2180 FORTUNE DRIVE SAN JOSE, CA 95131 USA
TEL +1 (408) 944-0800 FAX +1 (408) 474-1000 WEB <http://www.micrel.com>

The information furnished by Micrel in this data sheet is believed to be accurate and reliable. However, no responsibility is assumed by Micrel for its use. Micrel reserves the right to change circuitry and specifications at any time without notification to the customer.

Micrel Products are not designed or authorized for use as components in life support appliances, devices or systems where malfunction of a product can reasonably be expected to result in personal injury. Life support devices or systems are devices or systems that (a) are intended for surgical implant into the body or (b) support or sustain life, and whose failure to perform can be reasonably expected to result in a significant injury to the user. A Purchaser's use or sale of Micrel Products for use in life support appliances, devices or systems is a Purchaser's own risk and Purchaser agrees to fully indemnify Micrel for any damages resulting from such use or sale.

© 1997 Micrel, Incorporated.