

## 26V/6A DC/DC Power Module

### Features

- No Compensation Required
- Up to 6A Output Current
- >93% Peak Efficiency
- Output Voltage:  $0.8V$  to  $0.85 \times V_{IN}$  with  $\pm 1\%$  Accuracy
- Adjustable Switching Frequency from 200 kHz to 600 kHz
- Enable Input and Open-Drain Power Good Output
- HyperLight Load (MIC45205-1) Improves Light Load Efficiency
- Hyper Speed Control (MIC45205-2) Architecture Enables Fast Transient Response
- Supports Safe Startup into Pre-Biased Output
- $-40^{\circ}C$  to  $+125^{\circ}C$  Junction Temperature Range
- Thermal Shutdown Protection
- Short-Circuit Protection with Hiccup Mode
- Adjustable Current-Limit
- Available in 52-pin  $8\text{ mm} \times 8\text{ mm} \times 3\text{ mm}$  B1QFN Package

### Applications

- High Power Density Point-of-Load Conversion
- Servers, Routers, Networking, and Base Stations
- FPGAs, DSP, and Low-Voltage ASIC Power Supplies
- Industrial and Medical Equipment

### General Description

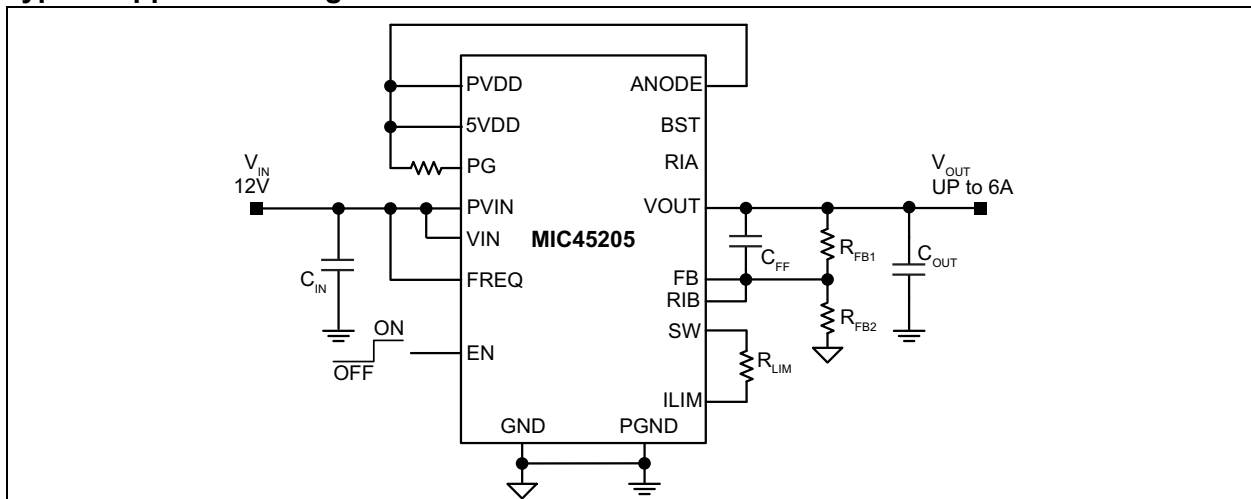
MIC45205 is a synchronous step-down regulator module, featuring a unique adaptive ON-time control architecture. The module incorporates a DC/DC controller, power MOSFETs, bootstrap diode, bootstrap capacitor, and an inductor in a single package; simplifying the design and layout process for the end user.

This highly integrated solution expedites system design and improves product time-to-market. The internal MOSFETs and inductor are optimized to achieve high efficiency at a low output voltage. The fully optimized design can deliver up to 6A current under a wide input voltage range of 4.5V to 26V, without requiring additional cooling.

The MIC45205-1 uses Microchip's HyperLight Load<sup>®</sup> (HLL) and the MIC45205-2 uses Microchip's Hyper Speed Control<sup>®</sup> architecture that enables ultra-fast load transient response, allowing for a reduction of output capacitance.

The MIC45205 offers 1% output accuracy that can be adjusted from 0.8V to  $0.85 \times V_{IN}$  with two external resistors. Additional features include thermal shutdown protection, input undervoltage lockout, adjustable current-limit, and short-circuit protection. The MIC45205 allows for safe start-up into a pre-biased output.

### Typical Application Diagram





## 1.0 ELECTRICAL CHARACTERISTICS

### Absolute Maximum Ratings †

$V_{PVIN}$ , $V_{VIN}$ to PGND .....	-0.3V to +30V
$V_{PVDD}$ , $V_{5VDD}$ , $V_{ANODE}$ to PGND.....	-0.3V to +6V
$V_{SW}$ , $V_{FREQ}$ , $V_{ILIM}$ , $V_{EN}$ to PGND.....	-0.3V to ( $V_{IN} + 0.3V$ )
$V_{BST}$ to $V_{SW}$ .....	-0.3V to +6V
$V_{BST}$ to PGND.....	-0.3V to +36V
$V_{PG}$ to PGND .....	-0.3V to ( $5V_{DD} + 0.3V$ )
$V_{FB}$ , $V_{RIB}$ to PGND .....	-0.3V to ( $5V_{DD} + 0.3V$ )
PGND to GND.....	-0.3V to +0.3V

### Operating Ratings ‡

Supply Voltage ( $V_{PVIN}$ , $V_{VIN}$ ) .....	+4.5V to +26V
Output Current .....	6A
Enable Input ( $V_{EN}$ ).....	0V to $V_{IN}$
Power Good ( $V_{PG}$ ).....	0V to $5V_{DD}$

† **Notice:** Stresses above those listed under “Absolute Maximum Ratings” may cause permanent damage to the device. This is a stress rating only and functional operation of the device at those or any other conditions above those indicated in the operational sections of this specification is not intended. Exposure to maximum rating conditions for extended periods may affect device reliability.

‡ **Notice:** The device is not guaranteed to function outside its operating ratings.

## ELECTRICAL CHARACTERISTICS

**Electrical Characteristics:**  $V_{IN} = V_{EN} = 12V$ ,  $V_{OUT} = 3.3V$ ,  $V_{BST} - V_{SW} = 5V$ ,  $T_J = +25^\circ C$ . **Bold** values indicate  $-40^\circ C < T_J < +125^\circ C$ , unless otherwise noted. [Note 1](#)

Parameter	Symbol	Min.	Typ.	Max.	Units	Conditions
<b>Power Supply Input</b>						
Input Voltage Range	$V_{IN}$ , $PV_{IN}$	<b>4.5</b>	—	<b>26</b>	V	—
Quiescent Supply Current (MIC45205-1)	$I_Q$	—	0.35	<b>0.75</b>	mA	$V_{FB} = 1.5V$
Quiescent Supply Current (MIC45205-2)	$I_Q$	—	2.1	<b>3</b>	mA	$V_{FB} = 1.5V$
Operating Current	$I_{IN}$	—	31	—	mA	$V_{PVIN} = V_{IN} = 12V$ , $V_{OUT} = 1.8V$ , $I_{OUT} = 0A$ $f_{SW} = 600\text{ kHz}$ (MIC45205-2)
Shutdown Supply Current	$I_{SHDN}$	—	0.1	<b>10</b>	$\mu A$	SW = unconnected, $V_{EN} = 0V$
<b>5V<sub>DD</sub> Output</b>						
5V <sub>DD</sub> Output Voltage	$5V_{DD}$	<b>4.8</b>	5.1	<b>5.4</b>	V	$V_{IN} = 7V$ to 26V, $I_{5VDD} = 10\text{ mA}$
5V <sub>DD</sub> UVLO Threshold	UVLO	<b>3.8</b>	4.2	<b>4.6</b>	V	$V_{5VDD}$ rising
5V <sub>DD</sub> UVLO Hysteresis	UVLO_HYS	—	400	—	mV	$V_{5VDD}$ falling
LDO Load Regulation	$\Delta 5V_{DD(LR)}$	0.6	2	3.6	%	$I_{5VDD} = 0\text{ mA}$ to 40 mA
<b>Reference</b>						
Feedback Reference Voltage	$V_{REF}$	0.792	0.8	0.808	V	$T_J = +25^\circ C$
		<b>0.784</b>	0.8	<b>0.816</b>		$-40^\circ C \leq T_J \leq +125^\circ C$
FB Bias Current	$I_{FB\_BIAS}$	—	5	<b>500</b>	nA	$V_{FB} = 0.8V$
<b>Enable Control</b>						
EN Logic Level High	EN <sub>HIGH</sub>	<b>1.8</b>	—	—	V	—
EN Logic Level Low	EN <sub>LOW</sub>	—	—	<b>0.6</b>	V	—

# MIC45205

## ELECTRICAL CHARACTERISTICS (CONTINUED)

**Electrical Characteristics:**  $V_{IN} = V_{EN} = 12V$ ,  $V_{OUT} = 3.3V$ ,  $V_{BST} - V_{SW} = 5V$ ,  $T_J = +25^\circ C$ . **Bold** values indicate  $-40^\circ C < T_J < +125^\circ C$ , unless otherwise noted. [Note 1](#)

Parameter	Symbol	Min.	Typ.	Max.	Units	Conditions
EN Hysteresis	$EN_{HYS}$	—	200	—	mV	—
EN Bias Current	$I_{ENBIAS}$	—	5	<b>10</b>	$\mu A$	$V_{EN} = 12V$
<b>Oscillator</b>						
Switching Frequency	$f_{SW}$	<b>400</b>	600	<b>750</b>	kHz	$V_{FREQ} = V_{IN}$ , $I_{OUT} = 2A$
		—	350	—		$V_{FREQ} = 50\% V_{IN}$ , $I_{OUT} = 2A$
Maximum Duty Cycle	$D_{MAX}$	—	85	—	%	—
Minimum Duty Cycle	$D_{MIN}$	—	0	—	%	$V_{FB} = 1V$
Minimum Off-Time	$t_{OFF(MIN)}$	140	200	260	ns	—
<b>Soft-Start</b>						
Soft-Start Time	$t_{SS}$	—	5	—	ms	$V_{FB}$ from 0V to 0.8V
<b>Short-Circuit Protection</b>						
Current-Limit Threshold	$V_{CL\_OFFSET}$	-30	-14	0	mV	$V_{FB} = 0.79V$
Short-Circuit Threshold	$V_{SC}$	-23	-7	9	mV	$V_{FB} = 0V$
Current-Limit Source Current	$I_{CL}$	55	70	85	$\mu A$	$V_{FB} = 0.79V$
Short-Circuit Source Current	$I_{SC}$	25	35	45	$\mu A$	$V_{FB} = 0V$
<b>Leakage</b>						
SW, BST Leakage Current	$I_{SW\_LEAKAGE}$	—	—	10	$\mu A$	—
FREQ Leakage Current	$I_{FREQ\_LEAK}$	—	—	10	$\mu A$	—
<b>Power Good (PG)</b>						
PG Threshold Voltage	$V_{PG\_TH}$	<b>85</b>	90	<b>95</b>	% $V_{REF}$	Sweep $V_{FB}$ from Low-to-High
PG Hysteresis	$V_{PG\_HYS}$	—	6	—	% $V_{REF}$	Sweep $V_{FB}$ from High-to-Low
PG Delay Time	$t_{PG\_DLY}$	—	100	—	$\mu s$	Sweep $V_{FB}$ from Low-to-High
PG Low Voltage	$V_{PG\_LOW}$	—	70	<b>200</b>	mV	$V_{FB} < 90\% \times V_{NOM}$ , $I_{PG} = 1 mA$
<b>Thermal Protection</b>						
Overtemperature Shutdown	$T_{SHD}$	—	160	—	$^\circ C$	$T_J$ rising
Overtemperature Shutdown Hysteresis	$T_{SHD\_HYS}$	—	15	—	$^\circ C$	—

**Note 1:** Specification for packaged product only.

## TEMPERATURE SPECIFICATIONS (Note 1)

Parameters	Sym.	Min.	Typ.	Max.	Units	Conditions
<b>Temperature Ranges</b>						
Operating Junction Temperature Range	$T_J$	-40	—	+125	°C	—
Absolute Maximum Junction Temperature	$T_{J(ABSMAX)}$	—	—	+150	°C	—
Storage Temperature Range	$T_S$	-65	—	+150	°C	—
Lead Temperature	$T_{LEAD}$	—	—	+260	°C	Soldering, 10s
<b>Package Thermal Resistances</b>						
Thermal Resistance B1QFN-52	$\theta_{JA}$	—	21.7	—	°C/W	<a href="#">Note 2</a>
Thermal Resistance B1QFN-52	$\theta_{JC}$	—	5.0	—	°C/W	<a href="#">Note 2</a>

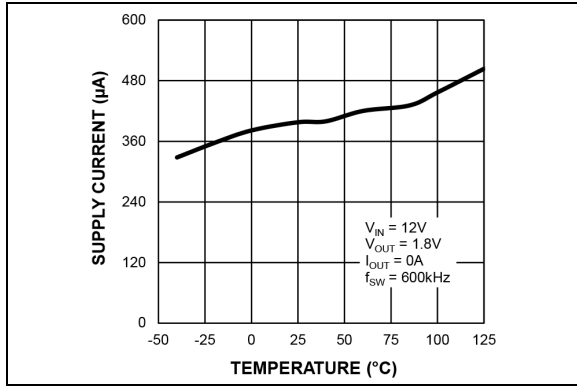
**Note 1:** The maximum allowable power dissipation is a function of ambient temperature, the maximum allowable junction temperature and the thermal resistance from junction to air (i.e.,  $T_A$ ,  $T_J$ ,  $\theta_{JA}$ ). Exceeding the maximum allowable power dissipation will cause the device operating junction temperature to exceed the maximum +125°C rating. Sustained junction temperatures above +125°C can impact the device reliability.

**2:**  $\theta_{JA}$  and  $\theta_{JC}$  were measured using the MIC45205 evaluation board.

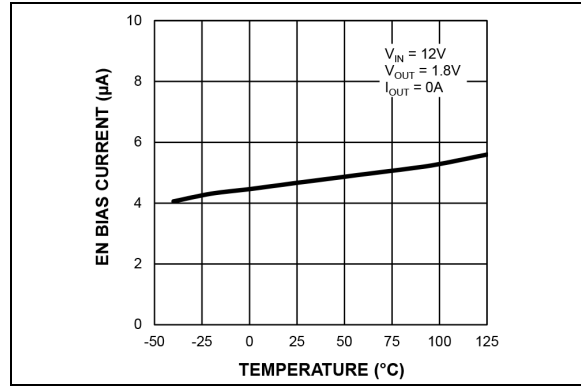
# MIC45205

## 2.0 TYPICAL PERFORMANCE CURVES

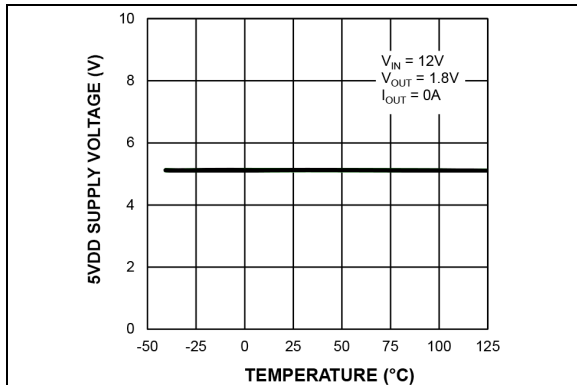
**Note:** The graphs and tables provided following this note are a statistical summary based on a limited number of samples and are provided for informational purposes only. The performance characteristics listed herein are not tested or guaranteed. In some graphs or tables, the data presented may be outside the specified operating range (e.g., outside specified power supply range) and therefore outside the warranted range.



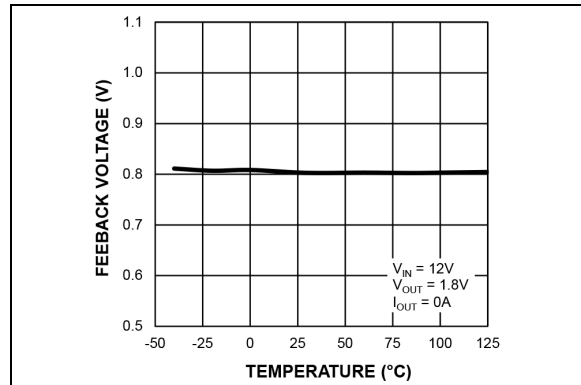
**FIGURE 2-1:**  $V_{IN}$  Operating Supply Current vs. Temperature (MIC45205-1).



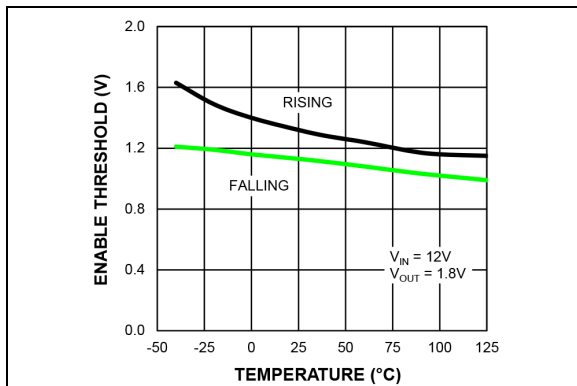
**FIGURE 2-4:** EN Bias Current vs. Temperature.



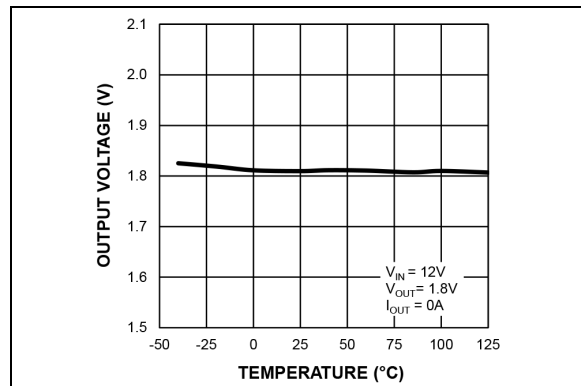
**FIGURE 2-2:**  $5V_{DD}$  Supply Voltage vs. Temperature.



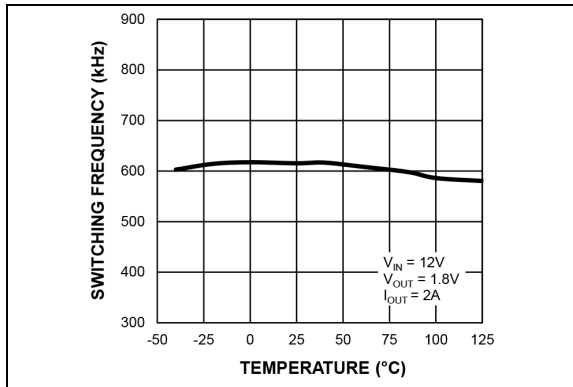
**FIGURE 2-5:** Feedback Voltage vs. Temperature.



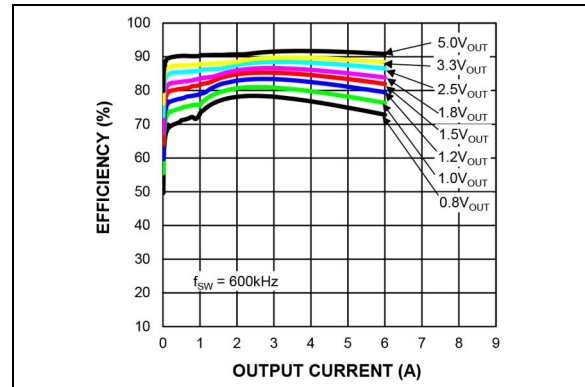
**FIGURE 2-3:** Enable Threshold vs. Temperature.



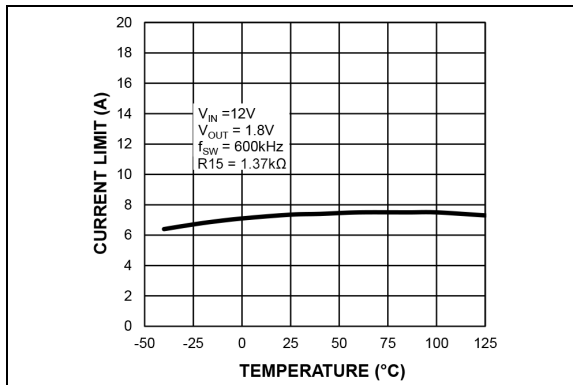
**FIGURE 2-6:** Output Voltage vs. Temperature.



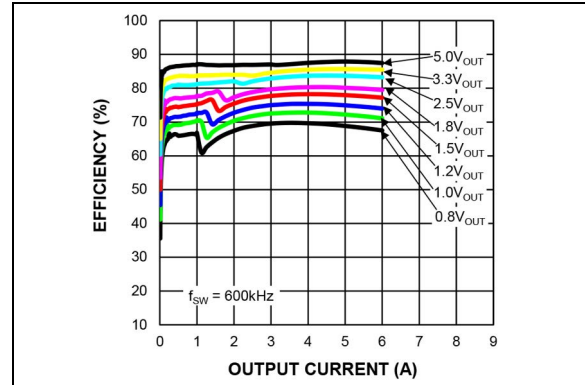
**FIGURE 2-7:** Switching Frequency vs. Temperature.



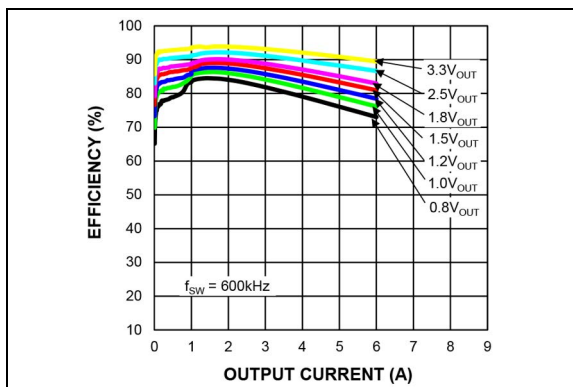
**FIGURE 2-10:** Efficiency ( $V_{IN} = 12V$ ) vs. Output Current (MIC45205-1).



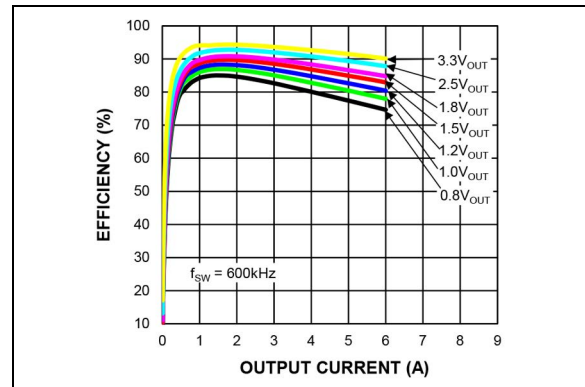
**FIGURE 2-8:** Output Peak Current Limit vs. Temperature.



**FIGURE 2-11:** Efficiency ( $V_{IN} = 24V$ ) vs. Output Current (MIC45205-1).

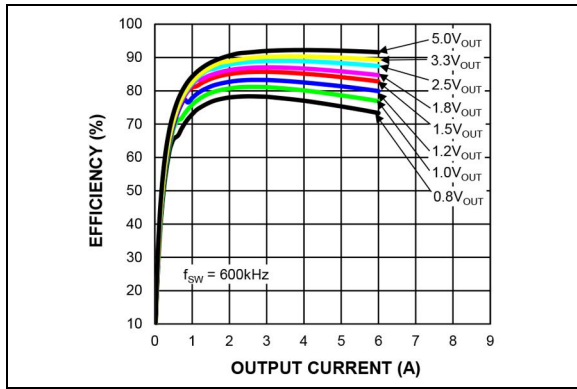


**FIGURE 2-9:** Efficiency ( $V_{IN} = 5V$ ) vs. Output Current (MIC45205-1).

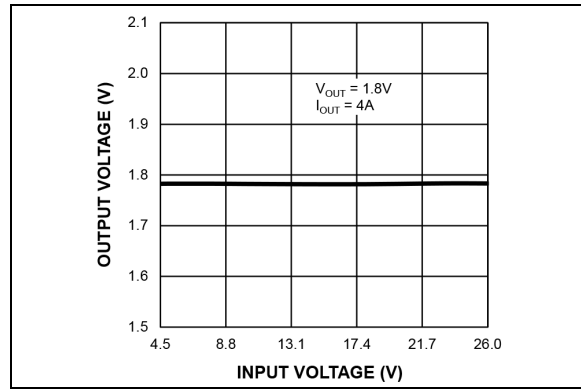


**FIGURE 2-12:** Efficiency ( $V_{IN} = 5V$ ) vs. Output Current (MIC45205-2).

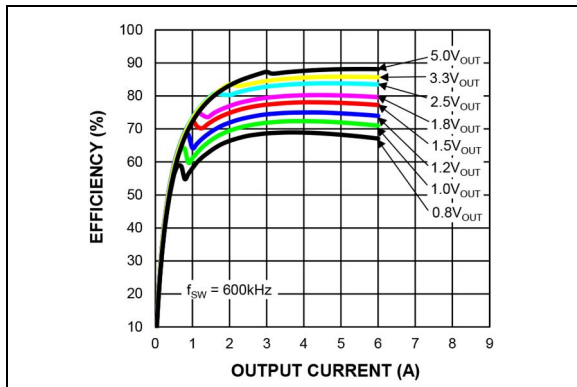
# MIC45205



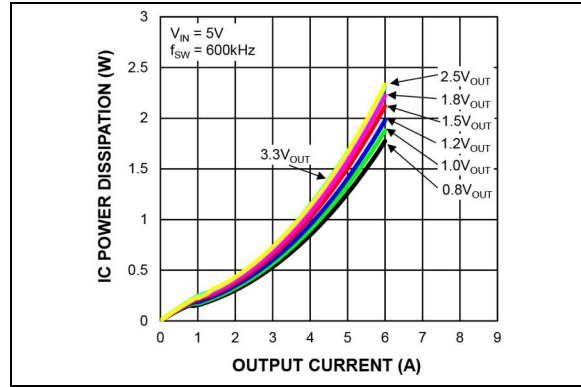
**FIGURE 2-13:** Efficiency ( $V_{IN} = 12V$ ) vs. Output Current (MIC45205-2).



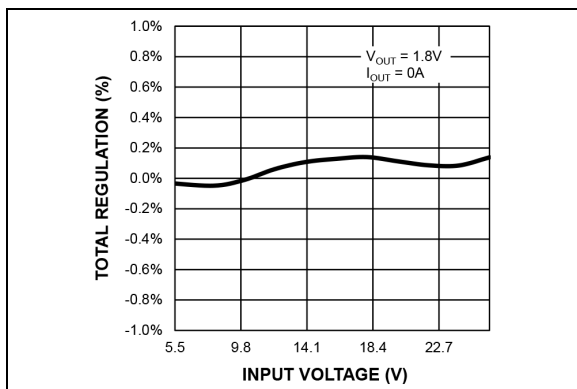
**FIGURE 2-16:** Output Voltage vs. Input Voltage.



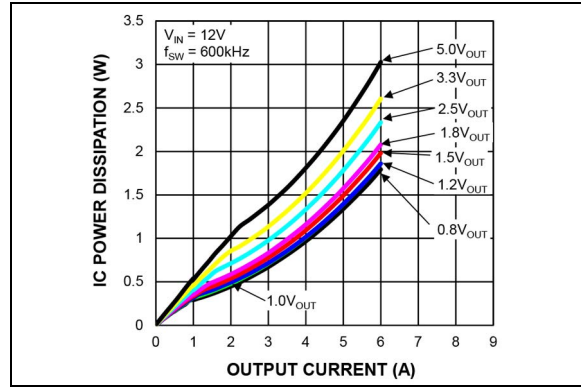
**FIGURE 2-14:** Efficiency ( $V_{IN} = 24V$ ) vs. Output Current (MIC45205-2).



**FIGURE 2-17:** IC Power Dissipation ( $V_{IN} = 5V$ ) vs. Output Current.

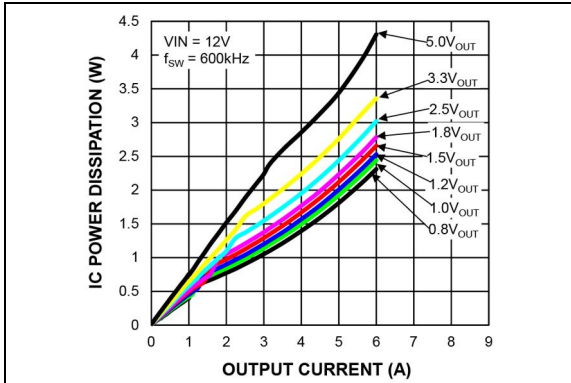


**FIGURE 2-15:** Line Regulation.

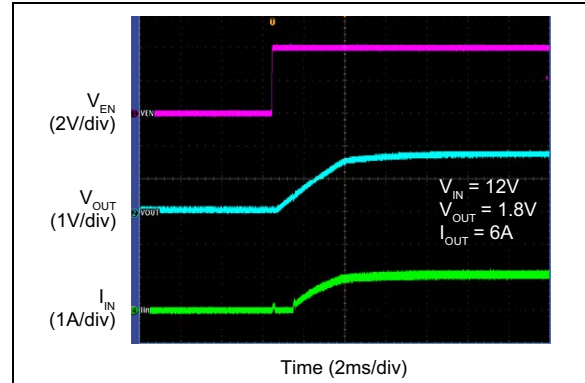


**FIGURE 2-18:** IC Power Dissipation ( $V_{IN} = 12V$ ) vs. Output Current.

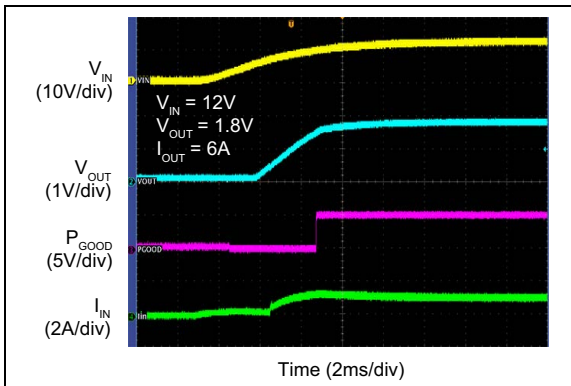




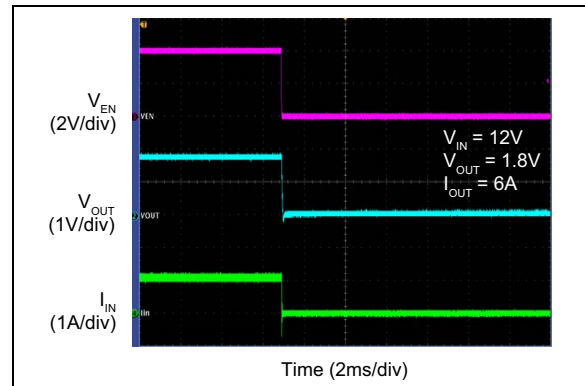
**FIGURE 2-19:** IC Power Dissipation ( $V_{IN} = 24V$ ) vs. Output Current.



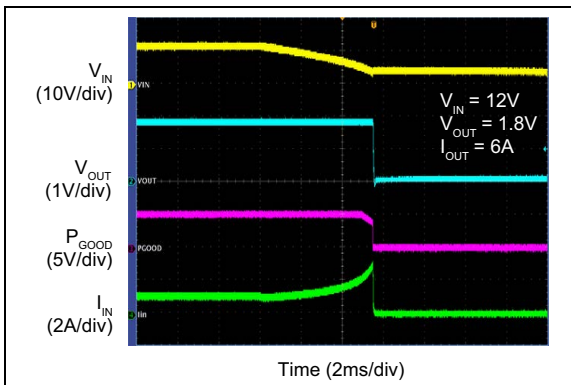
**FIGURE 2-22:** Enable Turn-On Delay and Rise Time.



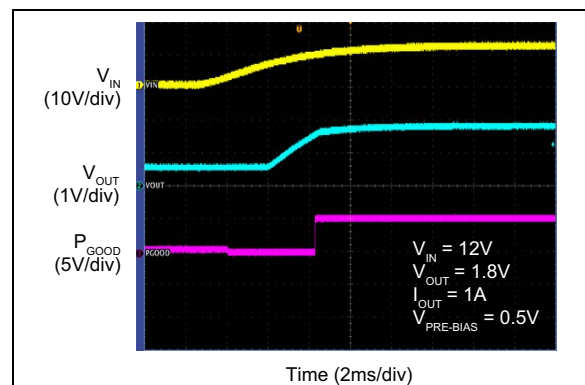
**FIGURE 2-20:**  $V_{IN}$  Soft Turn-On.



**FIGURE 2-23:** Enable Turn-Off Delay and Fall Time.

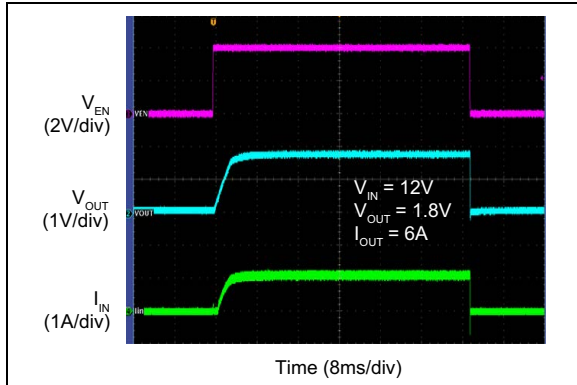


**FIGURE 2-21:**  $V_{IN}$  Soft Turn-Off.

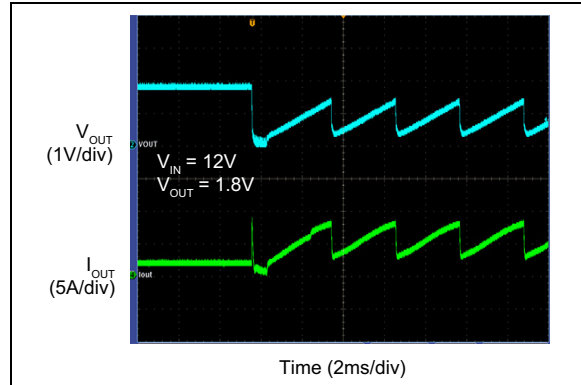


**FIGURE 2-24:**  $V_{IN}$  Start-Up with Pre-Biased Output.

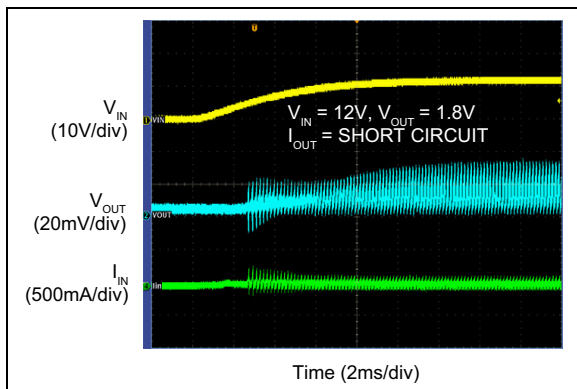
# MIC45205



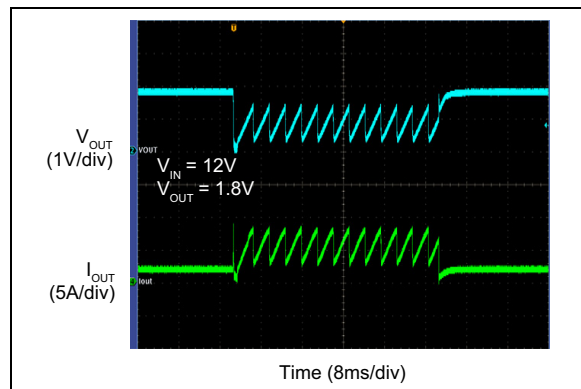
**FIGURE 2-25:** Enable Turn-On/Off.



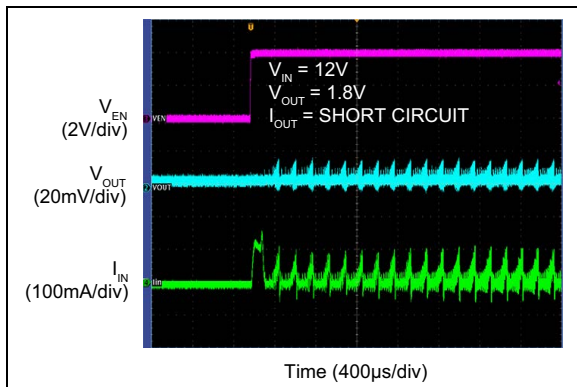
**FIGURE 2-28:** Short-Circuit.



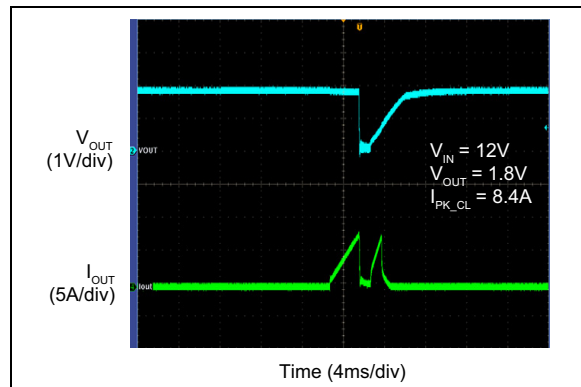
**FIGURE 2-26:** Power-Up Into Short-Circuit.



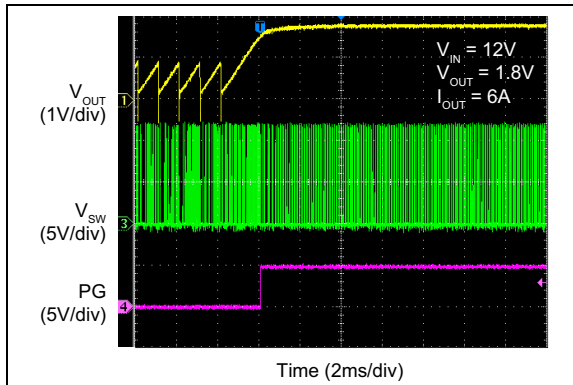
**FIGURE 2-29:** Output Recovery from Short-Circuit.



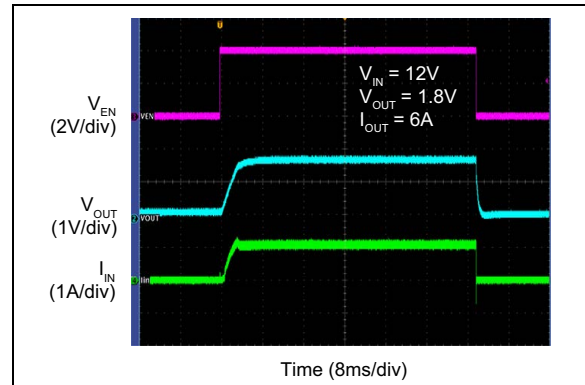
**FIGURE 2-27:** Enabled Into Short-Circuit.



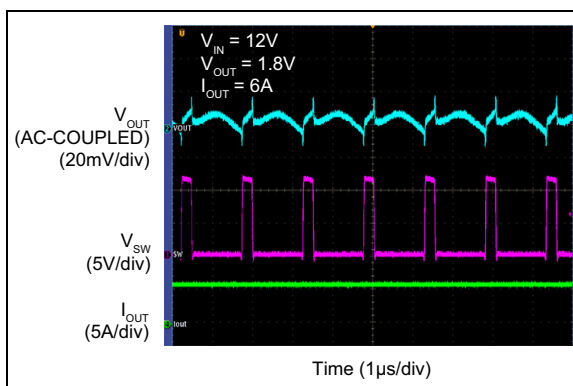
**FIGURE 2-30:** Peak Current-Limit Threshold.



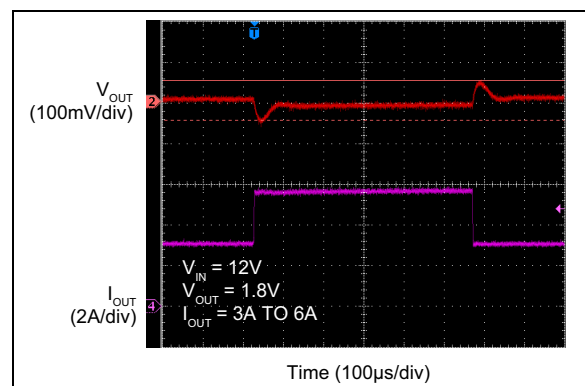
**FIGURE 2-31:** Output Recovery from Short-Circuit.



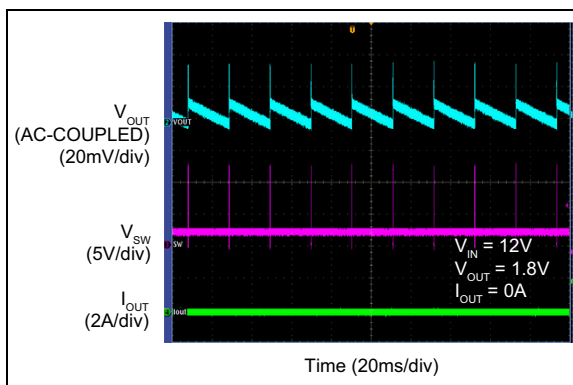
**FIGURE 2-34:** Inrush with  $C_{OUT} = 3000 \mu\text{F}$ .



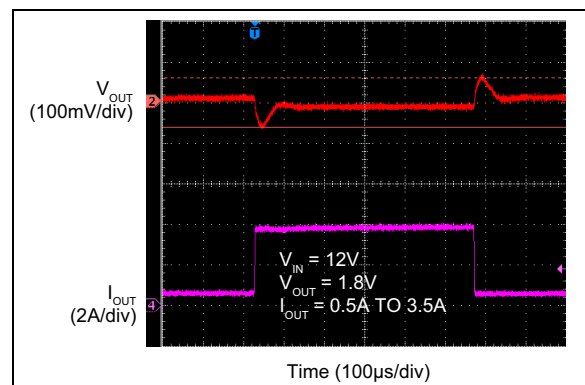
**FIGURE 2-32:** Switching Waveforms ( $I_{OUT} = 6\text{A}$ ).



**FIGURE 2-35:** Load Transient Response, MIC45205-1 ( $I_{OUT} = 3\text{A}$  to  $6\text{A}$ ).



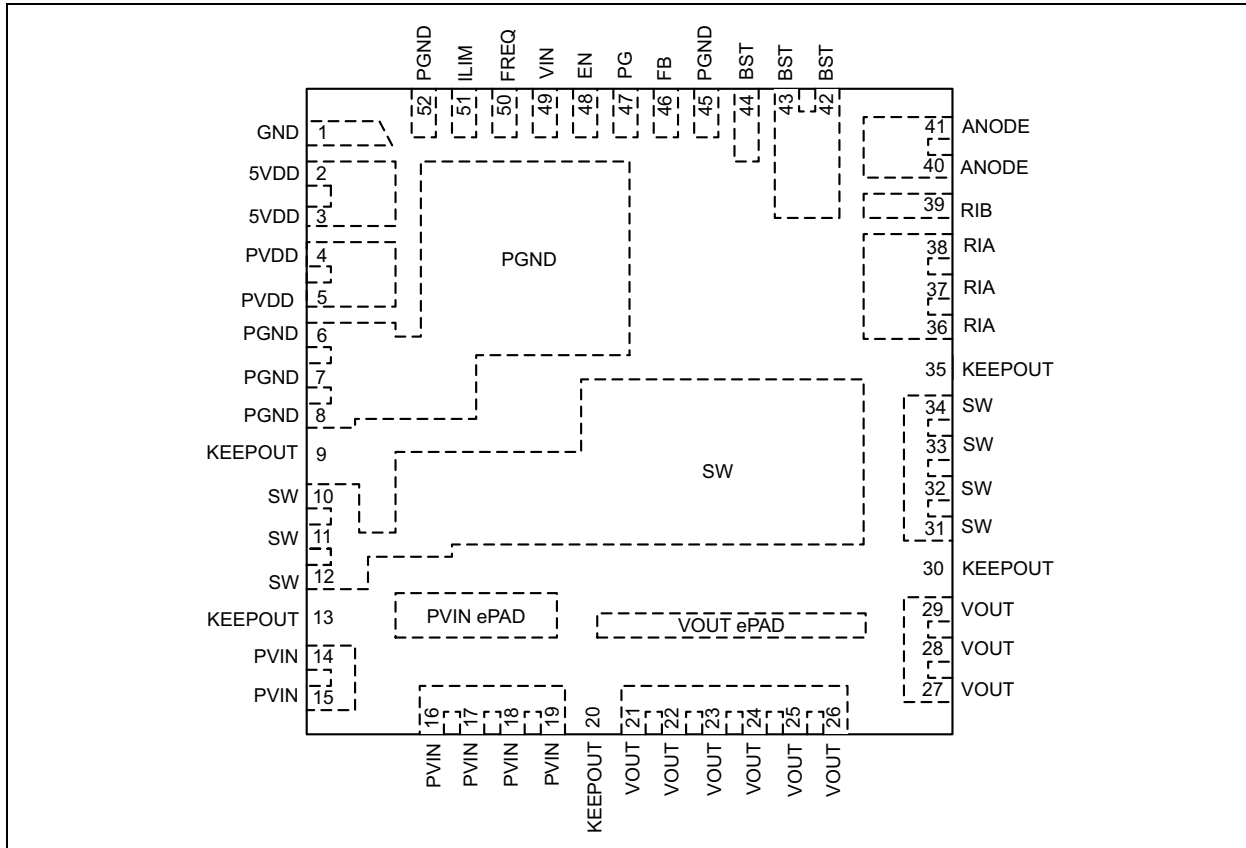
**FIGURE 2-33:** Switching Waveforms, MIC45205-1 ( $I_{OUT} = 0\text{A}$ ).



**FIGURE 2-36:** Load Transient Response, MIC45205-1 ( $I_{OUT} = 0.5\text{A}$  to  $3.5\text{A}$ ).

# MIC45205

## 3.0 PIN DESCRIPTIONS



**FIGURE 3-1:** MIC45205 Pin Configuration.

The descriptions of the pins are listed in [Table 3-1](#).

**TABLE 3-1: PIN FUNCTION TABLE**

Pin Number	Pin Name	Description
1	GND	Analog Ground. Connect bottom feedback resistor to GND. GND and PGND are internally connected.
2, 3	5V <sub>DD</sub>	Internal +5V Linear Regulator Output. Powered by V <sub>IN</sub> , 5V <sub>DD</sub> is the internal supply bus for the device. In the applications with V <sub>IN</sub> < +5.5V, 5V <sub>DD</sub> should be tied to V <sub>IN</sub> to bypass the linear regulator.
4, 5	PV <sub>DD</sub>	PV <sub>DD</sub> . Supply input for the internal low-side power MOSFET driver.
6, 7, 8, 45, 52	PGND	Power Ground. PGND is the return path for the step-down power module power stage. The PGND pin connects to the sources of internal low-side power MOSFET, the negative terminals of input capacitors, and the negative terminals of output capacitors.
10, 11, 12, 31, 32, 33, 34	SW	The SW pin connects directly to the switch node. Due to the high-speed switching on this pin, the SW pin should be routed away from sensitive nodes. The SW pin also senses the current by monitoring the voltage across the low-side MOSFET during OFF time.
14, 15, 16, 17, 18, 19	PV <sub>IN</sub>	Power Input Voltage. Connection to the drain of the internal high-side power MOSFET. Connect an input capacitor from PV <sub>IN</sub> to PGND.
21, 22, 23, 24, 25, 26, 27, 28, 29	V <sub>OUT</sub>	Output Voltage. Connected to the internal inductor, the output capacitor should be connected from this pin to PGND as close to the module as possible.
36, 37, 38	RIA	Ripple Injection Pin A. Leave floating, no connection.

**TABLE 3-1: PIN FUNCTION TABLE (CONTINUED)**

Pin Number	Pin Name	Description
39	RIB	Ripple Injection Pin B. Connect this pin to FB.
40, 41	ANODE	Anode Bootstrap Diode. Anode connection of internal bootstrap diode, this pin should be connected to the $PV_{DD}$ pin.
42, 43, 44	BST	Connection to the internal bootstrap circuitry and high-side power MOSFET drive circuitry. Connect all three BST pins together.
46	FB	Feedback. Input to the transconductance amplifier of the control loop. The FB pin is referenced to 0.8V. A resistor divider connecting the feedback to the output is used to set the desired output voltage. Connect the bottom resistor from FB to GND.
47	PG	Power Good. Open-drain output. If used, connect to an external pull-up resistor of at least 10 k $\Omega$ between PG and the external bias voltage.
48	EN	Enable. A logic signal to enable or disable the step-down regulator module operation. The EN pin is TTL/CMOS compatible. Logic-high = enable, logic-low = disable or shutdown. EN pin has an internal 1 M $\Omega$ (typical) pull-down resistor to GND. Do not leave floating.
49	$V_{IN}$	Internal 5V Linear Regulator Input. A 1 $\mu$ F ceramic capacitor from $V_{IN}$ to GND is required for decoupling.
50	FREQ	Switching Frequency Adjust. Use a resistor divider from $V_{IN}$ to GND to program the switching frequency. Connecting FREQ to $V_{IN}$ sets frequency at 600 kHz.
51	ILIM	Current Limit. Connect a resistor between ILIM and SW to program the current limit.
9, 13, 20, 30, 35	KEEPOUT	Depopulated pin positions.
—	$PV_{IN}$ ePAD	$PV_{IN}$ Exposed Pad. Internally connected to $PV_{IN}$ pins. Please see <a href="#">PCB Layout Guidelines</a> section.
—	$V_{OUT}$ ePAD	$V_{OUT}$ Exposed Pad. Internally connected to $V_{OUT}$ pins. Please see <a href="#">PCB Layout Guidelines</a> section.

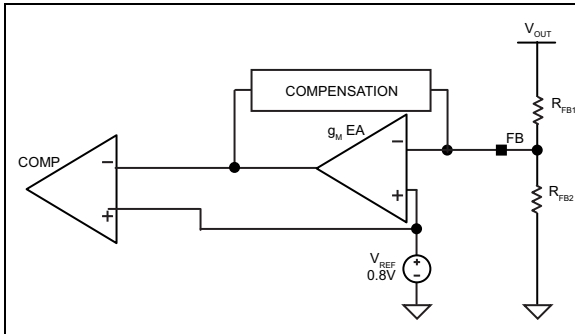
# MIC45205

## 4.0 FUNCTIONAL DESCRIPTION

The MIC45205 is an adaptive on-time synchronous buck regulator module built for high-input voltage to low-output voltage conversion applications. The MIC45205 is designed to operate over a wide input voltage range, from 4.5V to 26V, and the output is adjustable with an external resistor divider. An adaptive on-time control scheme is employed to obtain a constant switching frequency in steady state and to simplify the control compensation. Hiccup mode overcurrent protection is implemented by sensing low-side MOSFET's  $R_{DS(ON)}$ . The device features internal soft-start, enable, UVLO, and thermal shutdown. The module has integrated switching FETs, inductor, bootstrap diode, resistor, and capacitor.

### 4.1 Theory of Operation

As shown in Figure 4-1 (in association with Equation 4-1), the output voltage is sensed by the MIC45205 feedback pin (FB) via the voltage divider  $R_{FB1}$  and  $R_{FB2}$  and compared to a 0.8V reference voltage ( $V_{REF}$ ) at the error comparator through a low-gain transconductance ( $g_m$ ) amplifier. If the feedback voltage decreases, and the amplifier output falls below 0.8V, then the error comparator will trigger the control logic and generate an ON-time period. The ON-time period length is predetermined by the "Fixed  $t_{ON}$  Estimator" circuitry:



**FIGURE 4-1:** Output Voltage Sense via FB Pin.

#### EQUATION 4-1:

$$t_{ON(ESTIMATED)} = \frac{V_{OUT}}{V_{IN} \times f_{SW}}$$

Where:

- $V_{OUT}$  Output Voltage
- $V_{IN}$  Power Stage Input Voltage
- $f_{SW}$  Switching Frequency

At the end of the ON-time period, the internal high-side driver turns off the high-side MOSFET and the low-side driver turns on the low-side MOSFET. The OFF-time period length depends upon the feedback voltage in most cases. When the feedback voltage decreases and the output of the  $g_m$  amplifier falls below 0.8V, the ON-time period is triggered and the OFF-time period ends. If the OFF-time period determined by the feedback voltage is less than the minimum OFF-time  $t_{OFF(MIN)}$ , which is about 200 ns, the MIC45205 control logic will apply the  $t_{OFF(MIN)}$  instead.  $t_{OFF(MIN)}$  is required to maintain enough energy in the boost capacitor ( $C_{BST}$ ) to drive the high-side MOSFET.

The maximum duty cycle is obtained from the 200 ns  $t_{OFF(MIN)}$ :

#### EQUATION 4-2:

$$D_{MAX} = \frac{t_S - t_{OFF(MIN)}}{t_S} = 1 - \frac{200ns}{t_S}$$

Where:

$$t_S = 1/f_{SW}$$

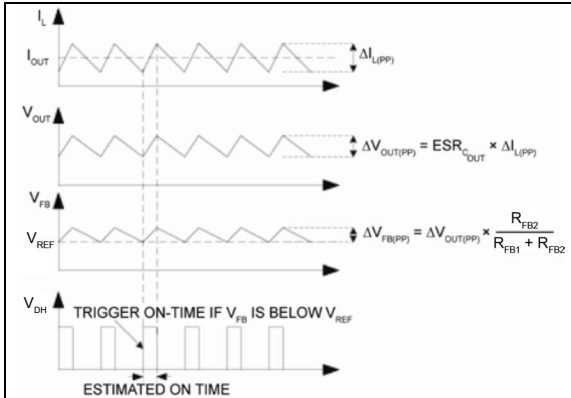
It is not recommended to use MIC45205 with an OFF-time close to  $t_{OFF(MIN)}$  during steady-state operation.

The adaptive ON-time control scheme results in a constant switching frequency in the MIC45205 during steady state operation. The actual ON-time and resulting switching frequency will vary with the different rising and falling times of the MOSFETs. Also, the minimum  $t_{ON}$  results in a lower switching frequency in high  $V_{IN}$  to  $V_{OUT}$  applications. During load transients, the switching frequency is changed due to the varying OFF-time.

To illustrate the control loop operation, we will analyze both the steady-state and load transient scenarios. For easy analysis, the gain of the  $g_m$  amplifier is assumed to be 1. With this assumption, the inverting input of the error comparator is the same as the feedback voltage.

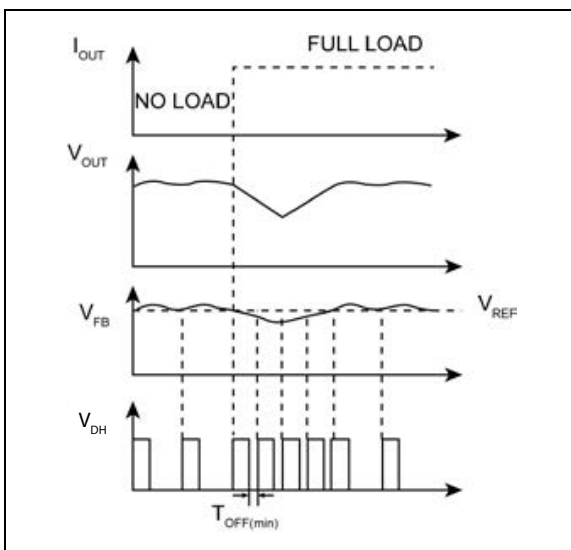
Figure 4-2 shows the MIC45205 control loop timing during steady-state operation. During steady-state, the  $g_m$  amplifier senses the feedback voltage ripple, which is proportional to the output voltage ripple plus injected voltage ripple, to trigger the ON-time period. The ON-time is predetermined by the  $t_{ON}$  estimator. The termination of the OFF-time is controlled by the feedback voltage. At the valley of the feedback voltage ripple, which occurs when  $V_{FB}$  falls below  $V_{REF}$ , the OFF period ends and the next ON-time period is triggered through the control logic circuitry.





**FIGURE 4-2:** MIC45205 Control Loop Timing.

Figure 4-3 shows the operation of the MIC45205 during a load transient. The output voltage drops due to the sudden load increase, which causes the  $V_{FB}$  to be less than  $V_{REF}$ . This will cause the error comparator to trigger an ON-time period. At the end of the ON-time period, a minimum OFF-time  $t_{OFF(MIN)}$  is generated to charge the bootstrap capacitor ( $C_{BST}$ ) because the feedback voltage is still below  $V_{REF}$ . Then, the next ON-time period is triggered due to the low feedback voltage. Therefore, the switching frequency changes during the load transient, but returns to the nominal fixed frequency once the output has stabilized at the new load current level. With the varying duty cycle and switching frequency, the output recovery time is fast and the output voltage deviation is small. Note that the instantaneous switching frequency during load transient remains bounded and cannot increase arbitrarily. The minimum is limited by  $t_{ON} + t_{OFF(MIN)}$ . Because the variation in  $V_{OUT}$  is relatively limited during load transient,  $t_{ON}$  stays virtually close to its steady-state value.



**FIGURE 4-3:** MIC45205 Load Transient Response.

Unlike true current-mode control, the MIC45205 uses the output voltage ripple to trigger an ON-time period. The output voltage ripple is proportional to the inductor current ripple if the ESR of the output capacitor is large enough.

In order to meet the stability requirements, the MIC45205 feedback voltage ripple should be in phase with the inductor current ripple and are large enough to be sensed by the  $g_m$  amplifier and the error comparator. The recommended feedback voltage ripple is 20 mV~100 mV over full input voltage range. If a low ESR output capacitor is selected, then the feedback voltage ripple may be too small to be sensed by the  $g_m$  amplifier and the error comparator. Also, the output voltage ripple and the feedback voltage ripple are not necessarily in phase with the inductor current ripple if the ESR of the output capacitor is very low. In these cases, ripple injection is required to ensure proper operation. Please refer to the [Ripple Injection](#) subsection in the [Application Information](#) section for more details about the ripple injection technique.

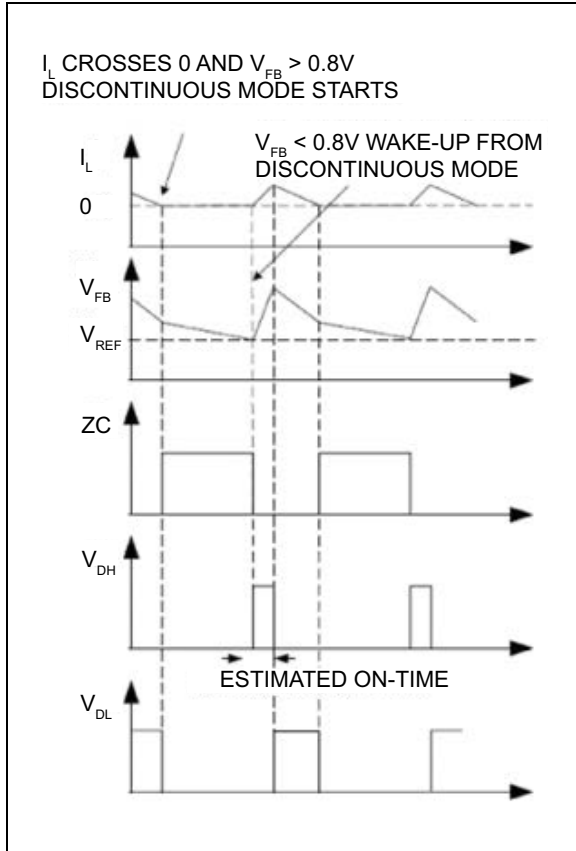
## 4.2 Discontinuous Mode (MIC45205-1 Only)

In continuous mode, the inductor current is always greater than zero. However, at light loads, the MIC45205-1 is able to force the inductor current to operate in discontinuous mode. Discontinuous mode is where the inductor current falls to zero, as indicated by trace ( $I_L$ ) shown in [Figure 4-4](#). During this period, the efficiency is optimized by shutting down all the non-essential circuits and minimizing the supply current as the switching frequency is reduced. The MIC45205-1 wakes up and turns on the high-side MOSFET when the feedback voltage  $V_{FB}$  drops below 0.8V.

The MIC45205-1 has a zero crossing comparator (ZC) that monitors the inductor current by sensing the voltage drop across the low-side MOSFET during its ON-time. If the  $V_{FB} > 0.8V$  and the inductor current goes slightly negative, then the MIC45205-1 automatically powers down most of the IC circuitry and goes into a low-power mode.

Once the MIC45205-1 goes into discontinuous mode, both DL and DH are low, which turns off the high-side and low-side MOSFETs. The load current is supplied by the output capacitors and  $V_{OUT}$  drops. If the drop of  $V_{OUT}$  causes  $V_{FB}$  to go below  $V_{REF}$ , then all the circuits will wake up into normal continuous mode. First, the bias currents of most circuits reduced during the discontinuous mode are restored, and then a  $t_{ON}$  pulse is triggered before the drivers are turned on to avoid any possible glitches. Finally, the high-side driver is turned on. [Figure 4-4](#) shows the control loop timing in discontinuous mode.

# MIC45205



**FIGURE 4-4:** MIC45205-1 Control Loop Timing (Discontinuous Mode).

During discontinuous mode, the bias current of most circuits is substantially reduced. As a result, the total power supply current during discontinuous mode is only about 350  $\mu$ A, allowing the MIC45205-1 to achieve high efficiency in light load applications.

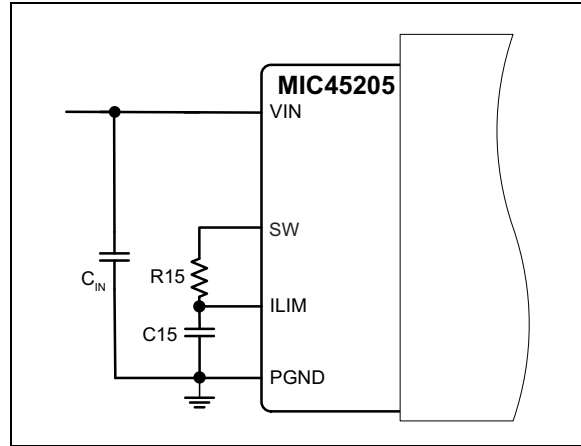
### 4.3 Soft-Start

Soft-start reduces the input power supply surge current at startup by controlling the output voltage rise time. The input surge appears while the output capacitor is charged up.

The MIC45205 implements an internal digital soft-start by making the 0.8V reference voltage  $V_{REF}$  ramp from 0 to 100% in about 5 ms with 9.7 mV steps. Therefore, the output voltage is controlled to increase slowly by a stair-case  $V_{FB}$  ramp. Once the soft-start cycle ends, the related circuitry is disabled to reduce current consumption.  $PV_{DD}$  must be powered up at the same time or after  $V_{IN}$  to make the soft-start function correctly.

### 4.4 Current-Limit

The MIC45205 uses the  $R_{DS(ON)}$  of the low-side MOSFET and external resistor connected from ILIM pin to SW node to set the current limit.



**FIGURE 4-5:** MIC45205 Current-Limiting Circuit.

In each switching cycle of the MIC45205, the inductor current is sensed by monitoring the low-side MOSFET in the OFF period. The sensed voltage  $V_{ILIM}$  is compared with the power ground (PGND) after a blanking time of 150 ns. In this way the drop voltage over the resistor R15 ( $V_{R15}$ ) is compared with the drop over the bottom FET generating the short current limit. The small capacitor (C15) connected from ILIM pin to PGND filters the switching node ringing during the off-time allowing a better short-limit measurement. The time constant created by R15 and C15 should be much less than the minimum off time.

The  $V_{R15}$  drop allows programming of short limit through the value of the resistor (R15). If the absolute value of the voltage drop on the bottom FET becomes greater than  $V_{R15}$ , and the  $V_{ILIM}$  falls below PGND, an overcurrent is triggered causing the IC to enter hiccup mode. The hiccup sequence including the soft-start reduces the stress on the switching FETs and protects the load and supply for severe short conditions.

The short-circuit current-limit can be programmed by using [Equation 4-3](#).

#### EQUATION 4-3:

$$R_{15} = \frac{(I_{CLIM} + \Delta I_{L(PP)} \times 0.5) \times R_{DS(ON)} + V_{CL\_OFFSET}}{I_{CL}}$$

Where:

- $I_{CLIM}$  Desired current limit.
- $R_{DS(ON)}$  On-resistance of low-side power MOSFET, 16 m $\Omega$  typically.
- $V_{CL\_OFFSET}$  Current-limit threshold offset (typ. 14 mV).
- $I_{CL}$  Current-limit source current (typ. 70  $\mu$ A).
- $\Delta I_{L(PP)}$  Inductor current peak-to-peak.



Because the inductor is integrated, use [Equation 4-4](#) to calculate the inductor ripple current.

**EQUATION 4-4:**

$$\Delta I_{L(PP)} = \frac{V_{OUT} \times (V_{IN(MAX)} - V_{OUT})}{V_{IN(MAX)} \times f_{SW} \times L}$$

The MIC45205 has a 1.0  $\mu\text{H}$  inductor integrated into the module. In case of a hard short, the short limit is folded down to allow an indefinite hard short on the output without any destructive effect.

It is mandatory to make sure that the inductor current used to charge the output capacitance during soft-start is under the folded short limit; otherwise the supply will go in hiccup mode and may not finish the soft-start successfully.

The MOSFET  $R_{DS(ON)}$  varies 30% to 40% with temperature; therefore, it is recommended to add a 50% margin to  $I_{CLIM}$  in [Equation 4-3](#) to avoid false current limiting due to increased MOSFET junction temperature rise.

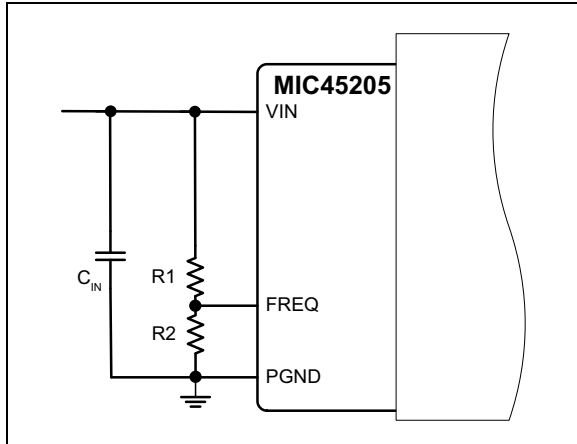
With  $R15 = 1.37 \text{ k}\Omega$  and  $C15 = 15 \text{ pF}$ , the typical output current-limit is 8A.

# MIC45205

## 5.0 APPLICATION INFORMATION

### 5.1 Setting the Switching Frequency

The MIC45205 switching frequency can be adjusted by changing the value of resistors R1 and R2.



**FIGURE 5-1:** Switching Frequency Adjustment.

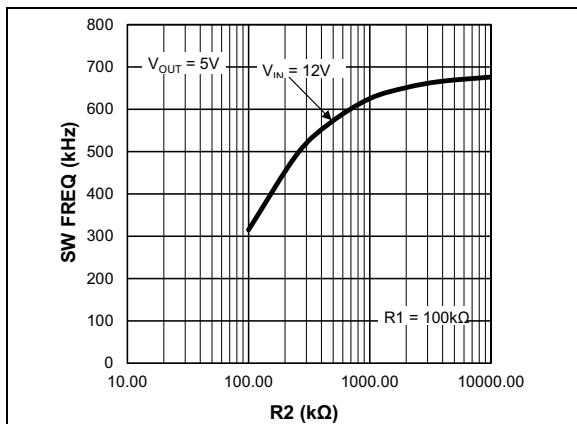
Equation 5-1 gives the estimated switching frequency:

#### EQUATION 5-1:

$$f_{SW} = f_O \times \frac{R2}{R1 + R2}$$

Where:

- $f_O$  600 kHz (typical per the Electrical Characteristics table).
- R1 100 k $\Omega$  is recommended.
- R2 Needs to be selected in order to set the required switching frequency.



**FIGURE 5-2:** Switching Frequency vs. R2.

### 5.2 Output Capacitor Selection

The type of the output capacitor is usually determined by the application and its equivalent series resistance (ESR). Voltage and RMS current capability are two other important factors for selecting the output capacitor. Recommended capacitor types are MLCC, OS-CON and POSCAP. The output capacitor's ESR is usually the main cause of the output ripple. The MIC45205 requires ripple injection and the output capacitor ESR affects the control loop from a stability point of view.

The maximum value of ESR is calculated as in Equation 5-2:

#### EQUATION 5-2:

$$ESR_{COUT} \leq \frac{\Delta V_{OUT(PP)}}{\Delta I_{L(PP)}}$$

Where:

- $\Delta V_{OUT(PP)}$  Peak-to-peak output voltage ripple
- $\Delta I_{L(PP)}$  Peak-to-peak inductor current ripple

The total output ripple voltage is a combination of ripple voltages due to the ESR and output capacitance. The total output ripple voltage is calculated in Equation 5-3:

#### EQUATION 5-3:

$$\Delta V_{OUT(PP)} = \sqrt{\left(\frac{\Delta I_{L(PP)}}{C_{OUT} \times f_{SW} \times 8}\right)^2 + (\Delta I_{L(PP)} \times ESR_{COUT})^2}$$

Where:

- $C_{OUT}$  Output Capacitance Value
- $f_{SW}$  Switching Frequency

As described in the Theory of Operation subsection in the Functional Description, the MIC45205 requires at least 20 mV peak-to-peak ripple at the FB pin to make the  $g_m$  amplifier and the error comparator behave properly. Also, the output voltage ripple should be in phase with the inductor current. Therefore, the output voltage ripple caused by the output capacitors value should be much smaller than the ripple caused by the output capacitor ESR. If low-ESR capacitors, such as ceramic capacitors, are selected as the output capacitors, a ripple injection method should be applied to provide enough feedback voltage ripple. Please refer to the Ripple Injection subsection in the Application Information section for more details.

The output capacitor RMS current is calculated in [Equation 5-4](#):

**EQUATION 5-4:**

$$I_{COUT(RMS)} = \frac{\Delta I_{L(PP)}}{\sqrt{12}}$$

The power dissipated in the output capacitor is:

**EQUATION 5-5:**

$$P_{DISS(COUT)} = I_{COUT(RMS)}^2 \times ESR_{COUT}$$

### 5.3 Input Capacitor Selection

The input capacitor for the power stage input  $PV_{IN}$  should be selected for ripple current rating and voltage rating. The input voltage ripple will primarily depend on the input capacitor's ESR. The peak input current is equal to the peak inductor current, so:

**EQUATION 5-6:**

$$\Delta V_{IN} = I_{L(PK)} \times ESR_{CIN}$$

The input capacitor must be rated for the input current ripple. The RMS value of input capacitor current is determined at the maximum output current. Assuming the peak-to-peak inductor current ripple is low:

**EQUATION 5-7:**

$$I_{CIN(RMS)} \approx I_{OUT(MAX)} \times \sqrt{D \times (1 - D)}$$

Where:

D Duty cycle

The power dissipated in the input capacitor is:

**EQUATION 5-8:**

$$P_{DISS(CIN)} = I_{CIN(RMS)}^2 \times ESR_{CIN}$$

The general rule is to pick the capacitor with a ripple current rating equal to or greater than the calculated worst-case RMS capacitor current.

[Equation 5-9](#) should be used to calculate the input capacitor. Also it is recommended to keep some margin on the calculated value:

**EQUATION 5-9:**

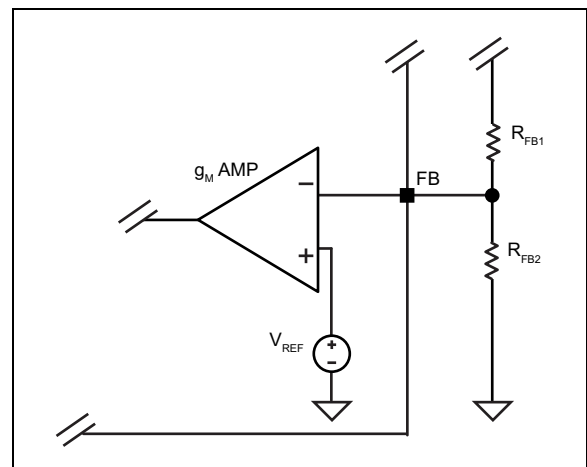
$$C_{IN} \approx \frac{I_{OUT(MAX)} \times (1 - D) \times D}{\eta \times f_{SW} \times dV}$$

Where:

dV Input ripple voltage  
 $f_{SW}$  Switching frequency  
 $\eta$  Power conversion efficiency

### 5.4 Output Voltage Setting Components

The MIC45205 requires two resistors to set the output voltage as shown in [Figure 5-3](#):



**FIGURE 5-3:** Voltage-Divider Configuration.

The output voltage is determined by [Equation 5-10](#):

# MIC45205

## EQUATION 5-10:

$$V_{OUT} = V_{REF} \times \left(1 + \frac{R_{FB1}}{R_{FB2}}\right)$$

Where:  
 $V_{REF} = 0.8V$

A typical value of  $R_{FB1}$  used on the standard evaluation board is 10 kΩ. If  $R_{FB1}$  is too large, it may allow noise to be introduced into the voltage feedback loop. If  $R_{FB1}$  is too small in value, it will decrease the efficiency of the power supply, especially at light loads. Once  $R_{FB1}$  is selected,  $R_{FB2}$  can be calculated using Equation 5-11:

## EQUATION 5-11:

$$R_{FB2} = \frac{V_{REF} \times R_{FB1}}{V_{OUT} - V_{REF}}$$

For fixed  $R_{FB1} = 10 \text{ k}\Omega$ , output voltage can be selected by  $R_{FB2}$ . Table 5-1 provides  $R_{FB2}$  values for some common output voltages.

**TABLE 5-1:  $V_{OUT}$  PROGRAMMING RESISTOR LOOK-UP**

$R_{FB2}$	$V_{OUT}$
OPEN	0.8V
40.2 kΩ	1.0V
20 kΩ	1.2V
11.5 kΩ	1.5V
8.06 kΩ	1.8V
4.75 kΩ	2.5V
3.24 kΩ	3.3V
1.91 kΩ	5.0V

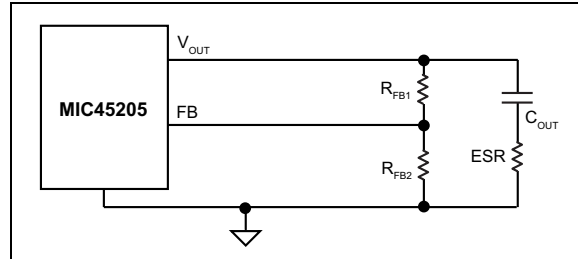
## 5.5 Ripple Injection

The  $V_{FB}$  ripple required for proper operation of the MIC45205  $g_m$  amplifier and error comparator is 20 mV to 100 mV. However, the output voltage ripple is generally too small to provide enough ripple amplitude at the FB pin and this issue is more visible in lower output voltage applications. If the feedback voltage ripple is so small that the  $g_m$  amplifier and error comparator cannot sense it, then the MIC45205 will lose control and the output voltage is not regulated. In order to have some amount of  $V_{FB}$  ripple, a ripple injection method is applied for low output voltage ripple applications.

The applications are divided into two situations according to the amount of the feedback voltage ripple:

1. Enough ripple at the feedback voltage due to the large ESR of the output capacitors:

As shown in Figure 5-4, the converter is stable without any ripple injection.



**FIGURE 5-4: Enough Ripple at FB from ESR.**

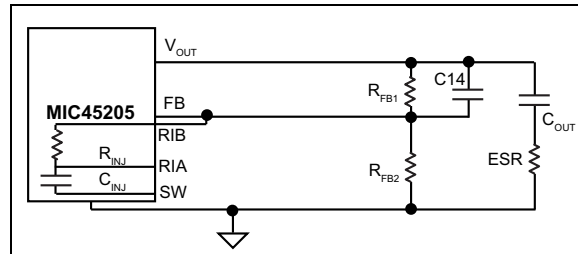
The feedback voltage ripple is:

## EQUATION 5-12:

$$\Delta V_{FB(PP)} = \frac{R_{FB2}}{R_{FB1} + R_{FB2}} \times ESR_{COUT} \times \Delta I_{L(PP)}$$

Where:  
 $\Delta I_{L(PP)}$  The peak-to-peak value of the inductor current ripple

2. Virtually no or inadequate ripple at the FB pin voltage due to the very-low ESR of the output capacitors, such as the case with ceramic output capacitor. In this case, the  $V_{FB}$  ripple waveform needs to be generated by injecting suitable signal. MIC45205 has provisions to enable an internal series RC injection network,  $R_{INJ}$  and  $C_{INJ}$  as shown in Figure 5-5 by connecting RIB to the FB pin. This network injects a square-wave current waveform into the FB pin, which, by means of integration across the capacitor ( $C_{14}$ ), generates an appropriate sawtooth FB ripple waveform.



**FIGURE 5-5: Internal Ripple Injection at FB via RIB Pin.**

The injected ripple is:

### EQUATION 5-13:

$$\Delta V_{FB(PP)} = V_{IN} \times K_{div} \times D \times (1-D) \times \frac{1}{f_{SW} \times \tau}$$

Where:

$V_{IN}$	Power stage input voltage
$D$	Duty cycle
$f_{SW}$	Switching frequency
$\tau$	$(R_{FB1} // R_{FB2} // R_{INJ}) \times C14$ $R_{INJ} = 10 \text{ k}\Omega$ , $C_{INJ} = 0.1 \text{ }\mu\text{F}$

### EQUATION 5-14:

$$K_{div} = \frac{R_{FB1} // R_{FB2}}{R_{INJ} + R_{FB1} // R_{FB2}}$$

Where:

$R_{INJ}$	10 k $\Omega$
-----------	---------------

In Equation 5-14 and Equation 5-15, it is assumed that the time constant associated with C14 must be much greater than the switching period:

### EQUATION 5-15:

$$\frac{1}{f_{SW} \times \tau} = \frac{T}{\tau} \ll 1$$

If the voltage divider resistors  $R_{FB1}$  and  $R_{FB2}$  are in the k $\Omega$  range, then a C14 of 1 nF to 100 nF can easily satisfy the large time constant requirements.

## 5.6 Thermal Measurements and Safe Operating Area (SOA)

Measuring the IC's case temperature is recommended to ensure it is within its operating limits. Although this might seem like a very elementary task, it is easy to get erroneous results. The most common mistake is to use the standard thermal couple that comes with a thermal meter. This thermal couple wire gauge is large, typically 22 gauge, and behaves like a heatsink, resulting in a lower case measurement.

Two methods of temperature measurement are using a smaller thermal couple wire or an infrared thermometer. If a thermal couple wire is used, it must be constructed of 36-gauge wire or higher (smaller wire size) to minimize the wire heat-sinking effect. In

addition, the thermal couple tip must be covered in either thermal grease or thermal glue to make sure that the thermal couple junction is making good contact with the case of the IC. Omega brand thermal couple (5SC-TT-K-36-36) is adequate for most applications.

Wherever possible, an infrared thermometer is recommended. The measurement spot size of most infrared thermometers is too large for an accurate reading on a small form factor ICs. However, an IR thermometer from Optris has a 1 mm spot size, which makes it a good choice for measuring the hottest point on the case. An optional stand makes it easy to hold the beam on the IC for long periods of time.

The safe operating area (SOA) of the MIC45205 is shown in Figure 5-6 through Figure 5-10. These thermal measurements were taken on MIC45205 evaluation board. Since the MIC45205 is an entire system comprised of switching regulator controller, MOSFETs and inductor, the part needs to be considered as a system. The SOA curves will give guidance to reasonable use of the MIC45205.

SOA curves should only be used as a point of reference. SOA data was acquired using the MIC45205 evaluation board. Thermal performance depends on the PCB layout, board size, copper thickness, number of thermal vias, and actual airflow.

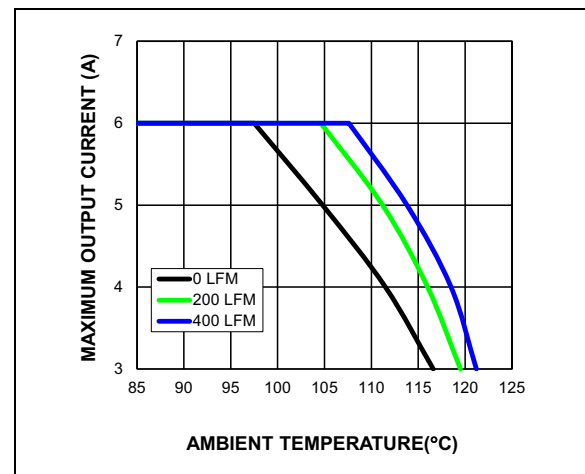
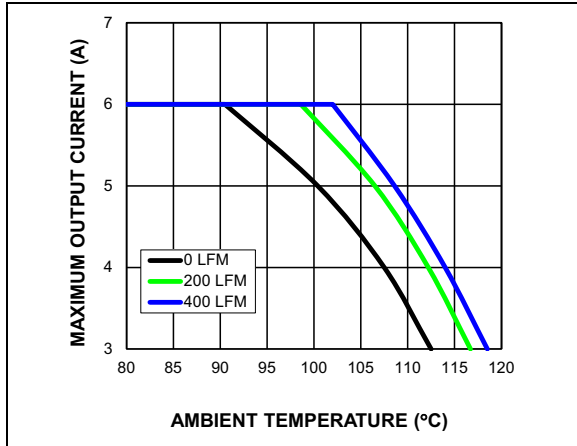
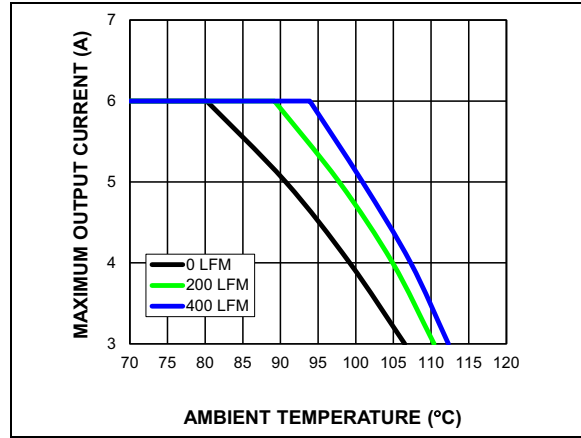


FIGURE 5-6: MIC45205 Power Derating vs. Airflow (5V<sub>IN</sub> to 1.5V<sub>OUT</sub>).

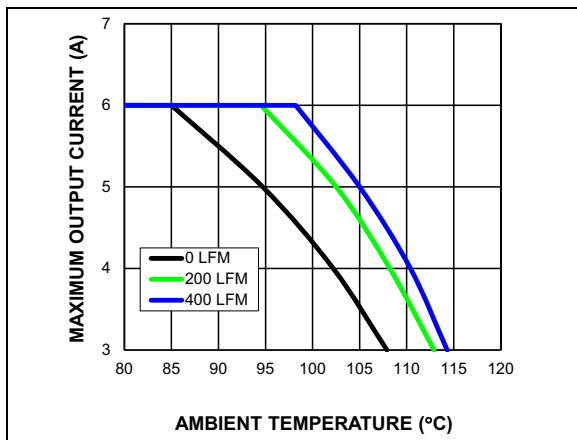
# MIC45205



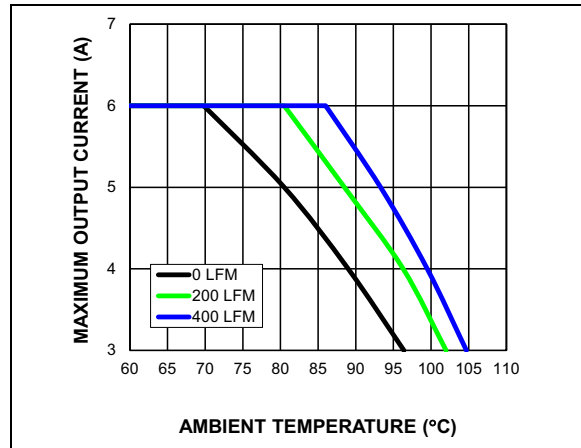
**FIGURE 5-7:** MIC45205 Power Derating vs. Airflow (12V<sub>IN</sub> to 1.5V<sub>OUT</sub>).



**FIGURE 5-9:** MIC45205 Power Derating vs. Airflow (24V<sub>IN</sub> to 1.5V<sub>OUT</sub>).



**FIGURE 5-8:** MIC45205 Power Derating vs. Airflow (12V<sub>IN</sub> to 3.3V<sub>OUT</sub>).



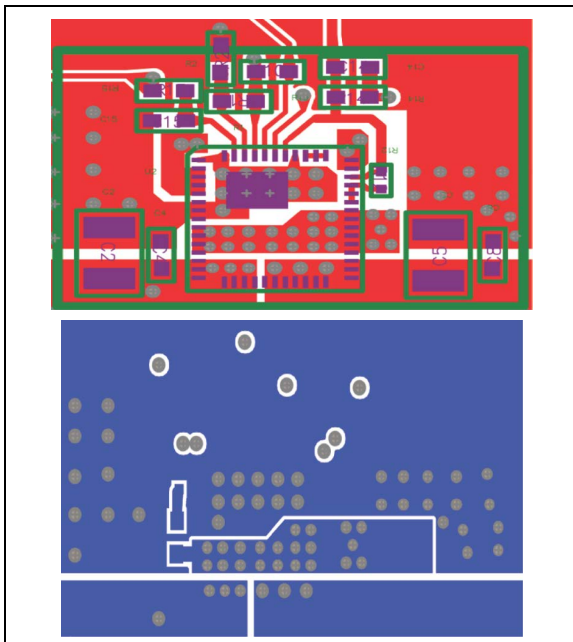
**FIGURE 5-10:** MIC45205 Power Derating vs. Airflow (24V<sub>IN</sub> to 3.3V<sub>OUT</sub>).

## 6.0 PCB LAYOUT GUIDELINES

To minimize EMI and output noise, follow these layout recommendations.

PCB layout is critical to achieve reliable, stable and efficient performance. A ground plane is required to control EMI and minimize the inductance in power, signal and return paths.

Figure 6-1 is optimized from a small form factor point of view shows top and bottom layer of a four layer PCB. It is recommended to use mid layer 1 as a continuous ground plane.



**FIGURE 6-1:** Top And Bottom Layer of a Four-Layer Board.

The following guidelines should be followed to insure proper operation of the MIC45205 module:

### 6.1 IC

- The analog ground pin (GND) must be connected directly to the ground planes. Place the IC close to the point-of-load (POL).
- Use thick traces to route the input and output power lines.
- Analog and power grounds should be kept separate and the analog ground (GND) and power ground (PGND) are internally connected.

### 6.2 Input Capacitor

- Place the input capacitors on the same side of the board and as close to the IC as possible.
- Place several vias to the ground plane close to the input capacitor ground terminal.
- Use either X7R or X5R dielectric input capacitors. Do not use Y5V or Z5U type capacitors.
- Do not replace the ceramic input capacitor with any other type of capacitor. Any type of capacitor can be placed in parallel with the ceramic input capacitor.
- If a non-ceramic input capacitor is placed in parallel with the input capacitor, it must be recommended for switching regulator applications and the operating voltage.
- In “Hot-Plug” applications, an Electrolytic bypass capacitor must be used to limit the over-voltage spike seen on the input supply with power is suddenly applied. If hot-plugging is the normal operation of the system, using an appropriate hot-swap IC is recommended.

### 6.3 RC Snubber (Optional)

- Depending on the operating conditions, a RC snubber on the same side of the board can be used. Place the RC and as close to the SW pin as possible if needed.

### 6.4 SW Node

- Do not route any digital lines underneath or close to the SW node.
- Keep the switch node (SW) away from the feedback (FB) pin.

### 6.5 Output Capacitor

- Use a wide trace to connect the output capacitor ground terminal to the input capacitor ground terminal.
- Phase margin will change as the output capacitor value and ESR changes.
- The feedback trace should be separate from the power trace and connected as close as possible to the output capacitor. Sensing a long high-current load trace can degrade the DC load regulation.

# MIC45205

## 6.6 PCB Layout Recommendations

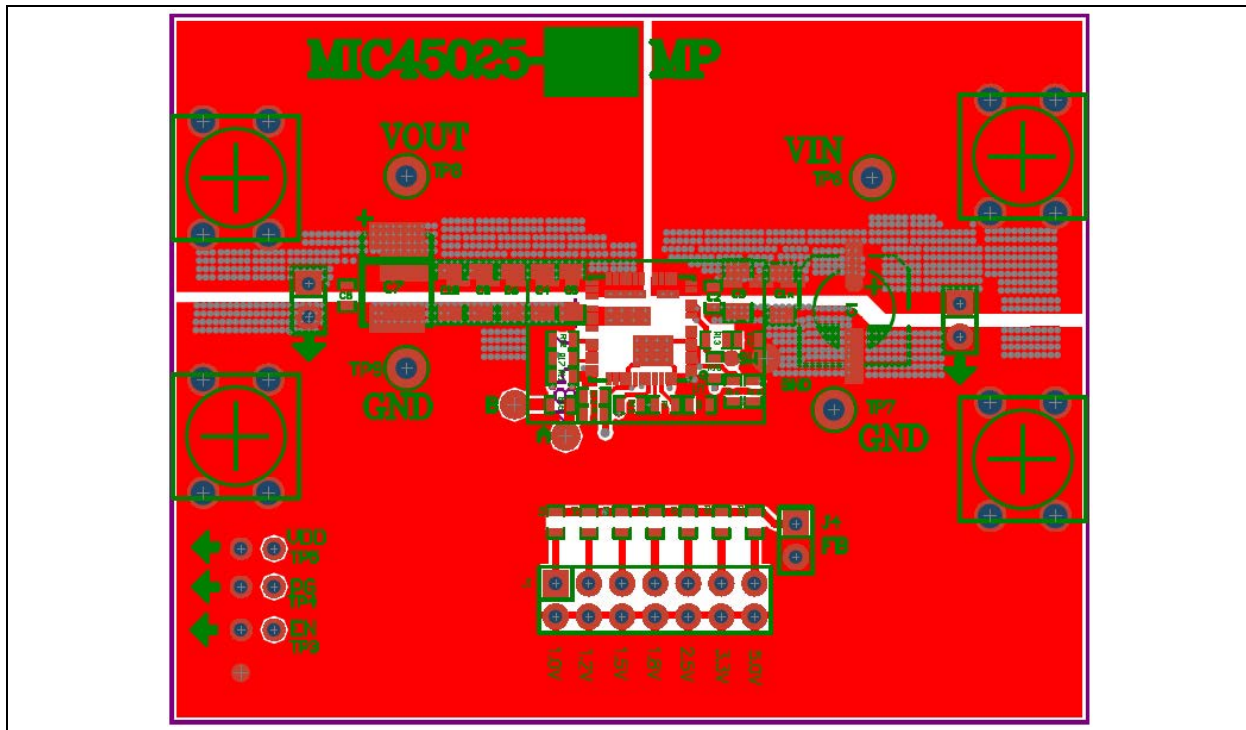


FIGURE 6-2: Top Copper Layer 1.

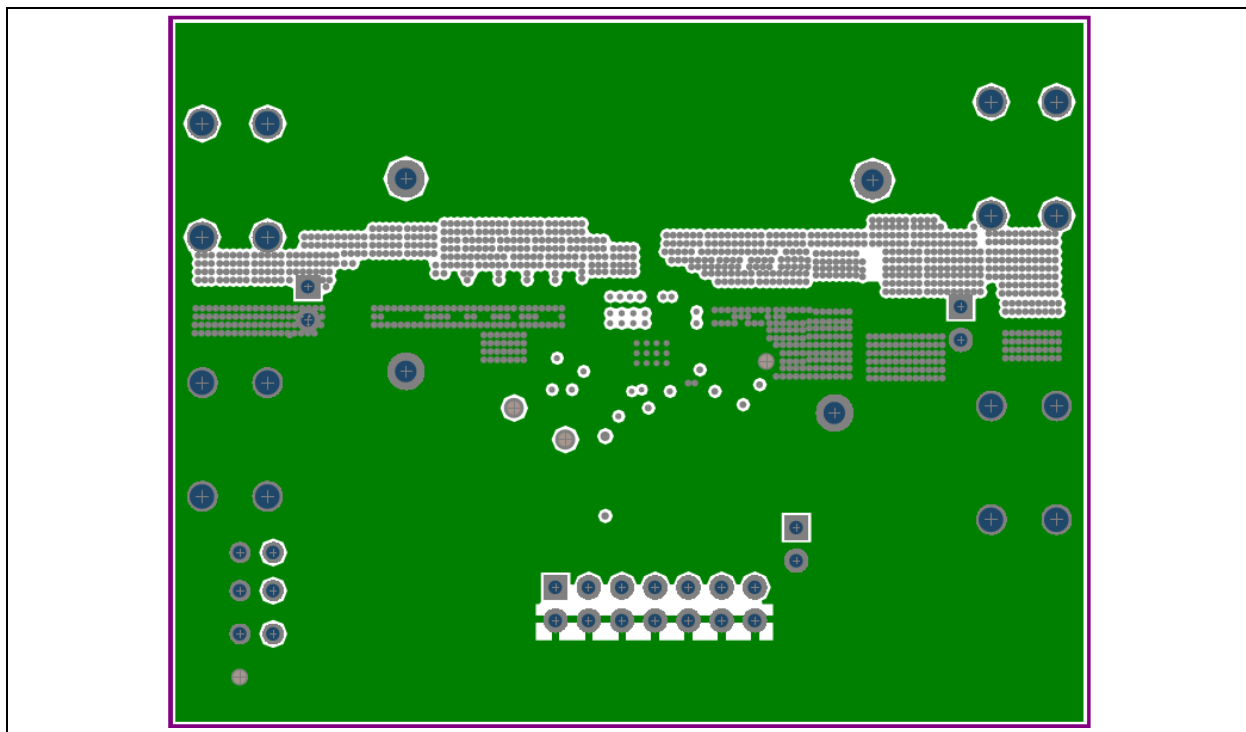
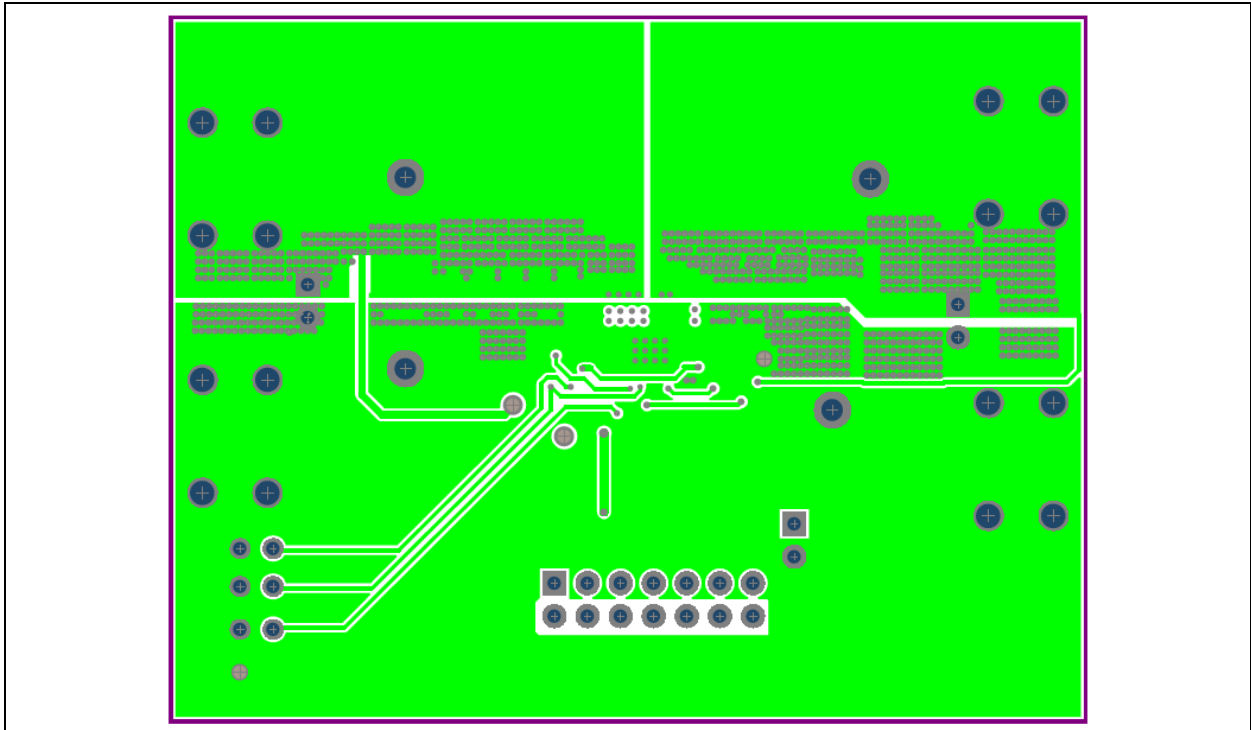
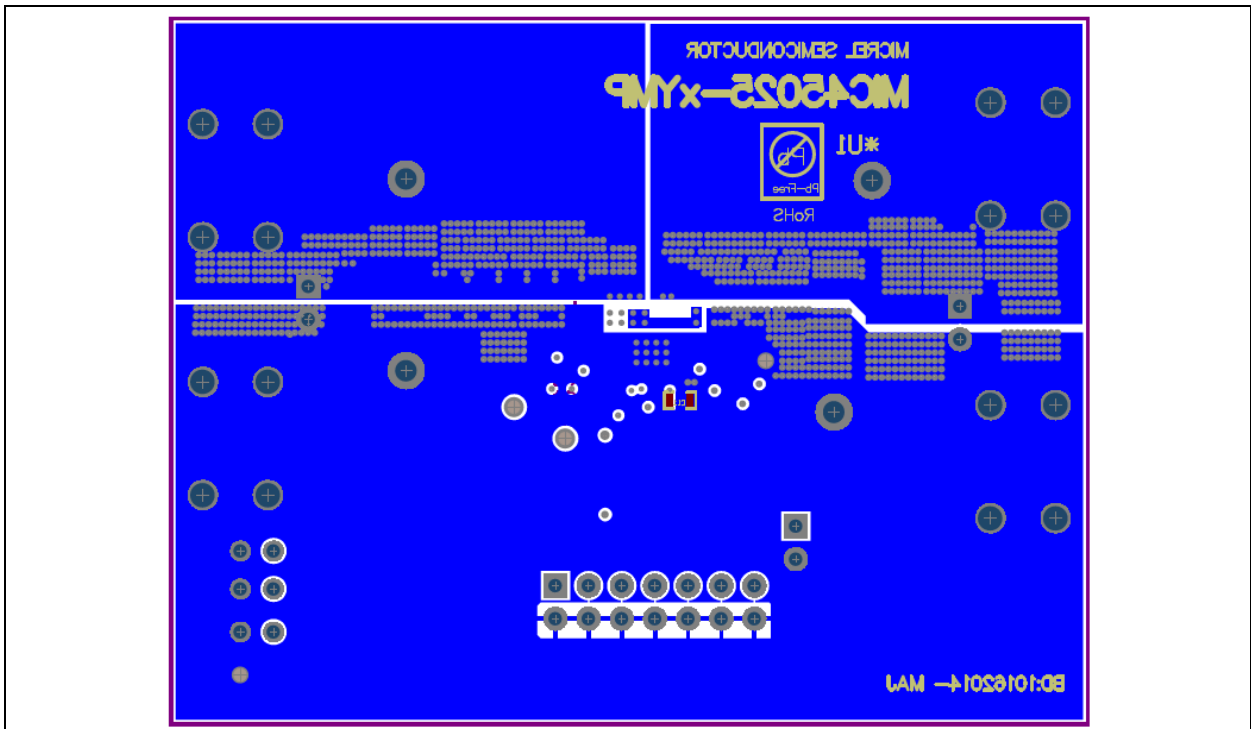


FIGURE 6-3: Copper Layer 2.





**FIGURE 6-4:** Copper Layer 3.



**FIGURE 6-5:** Bottom Copper Layer 4.

# MIC45205

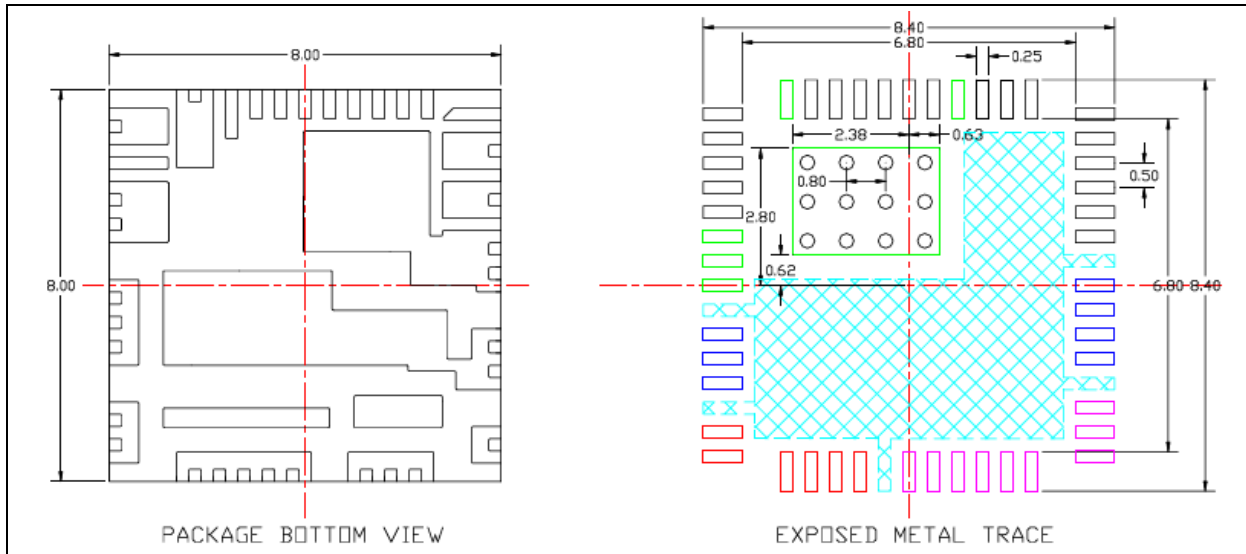
## 7.0 SIMPLIFIED PCB DESIGN RECOMMENDATIONS

### 7.1 Periphery I/O Pad Layout and Large Pad for Exposed Heatsink

The board design should begin with copper/metal pads that sit beneath the periphery leads of a mounted B1QFN. The board pads should extend outside the B1QFN package edge a distance of approximately 0.20 mm per side:

Total pad length =  $8.00 \text{ mm} + (0.20 \text{ mm per side} \times 2 \text{ sides}) = 8.40 \text{ mm}$ .

After completion of the periphery pad design, the larger exposed pads will be designed to create the mounting surface of the B1QFN exposed heatsink. The primary transfer of heat out of the B1QFN will be directly through the bottom surface of the exposed heatsink. To aid in the transfer of generated heat into the PCB, the use of an array of plated through-hole vias beneath the mounted part is recommended. The typical via hole diameter is 0.30 mm to 0.35 mm, with center-to-center pitch of 0.80 mm to 1.20 mm.



**FIGURE 7-1:** Package Bottom View vs. PCB Recommended Exposed Metal Trace.

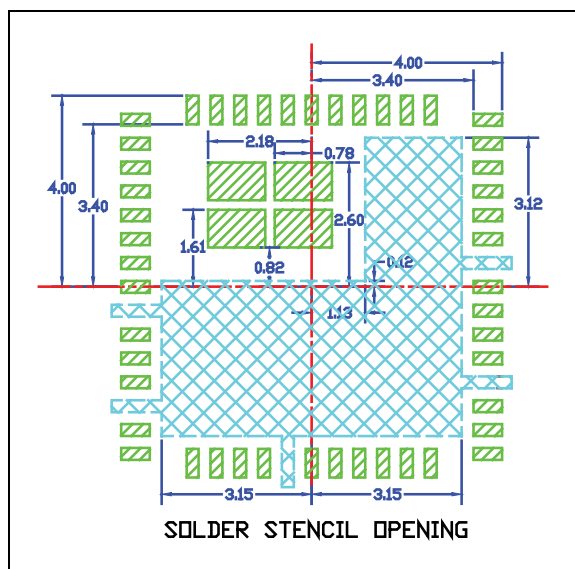
Please note that the exposed metal trace is a “mirror image” of the package bottom view.

## 7.2 Solder Paste Stencil Design (Recommend Stencil Thickness = 112.5 $\mu\text{m}$ $\pm$ 12.5 $\mu\text{m}$ )

The solder stencil aperture openings should be smaller than the periphery or large PCB exposed pads to reduce any chance of build-up of excess solder at the large exposed pad area which can result to solder bridging.

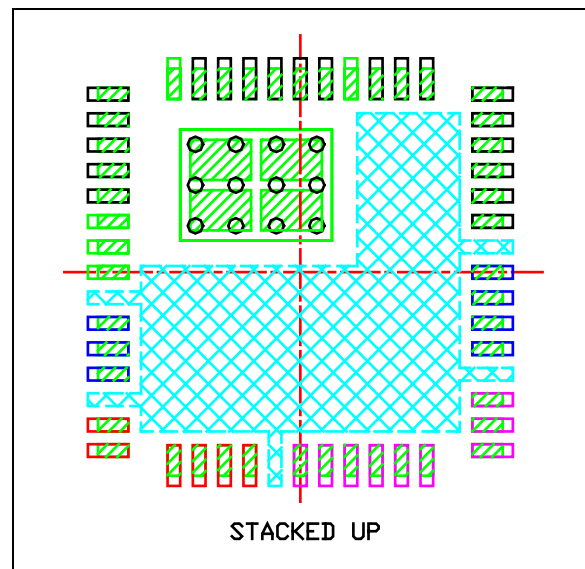
The suggested reduction of the stencil aperture opening is typically 0.20 mm smaller than exposed metal trace.

Please note that a critical requirement is to *not* duplicate land pattern of the exposed metal trace as solder stencil opening as the design and dimension values are different.



**FIGURE 7-2:** Solder Stencil Opening.

Note that the cyan-colored shaded pad indicates exposed trace keep out area.



**FIGURE 7-3:** Stack-Up of Pad Layout and Solder Paste Stencil.

# MIC45205

## 8.0 EVALUATION BOARD SCHEMATIC AND BOM

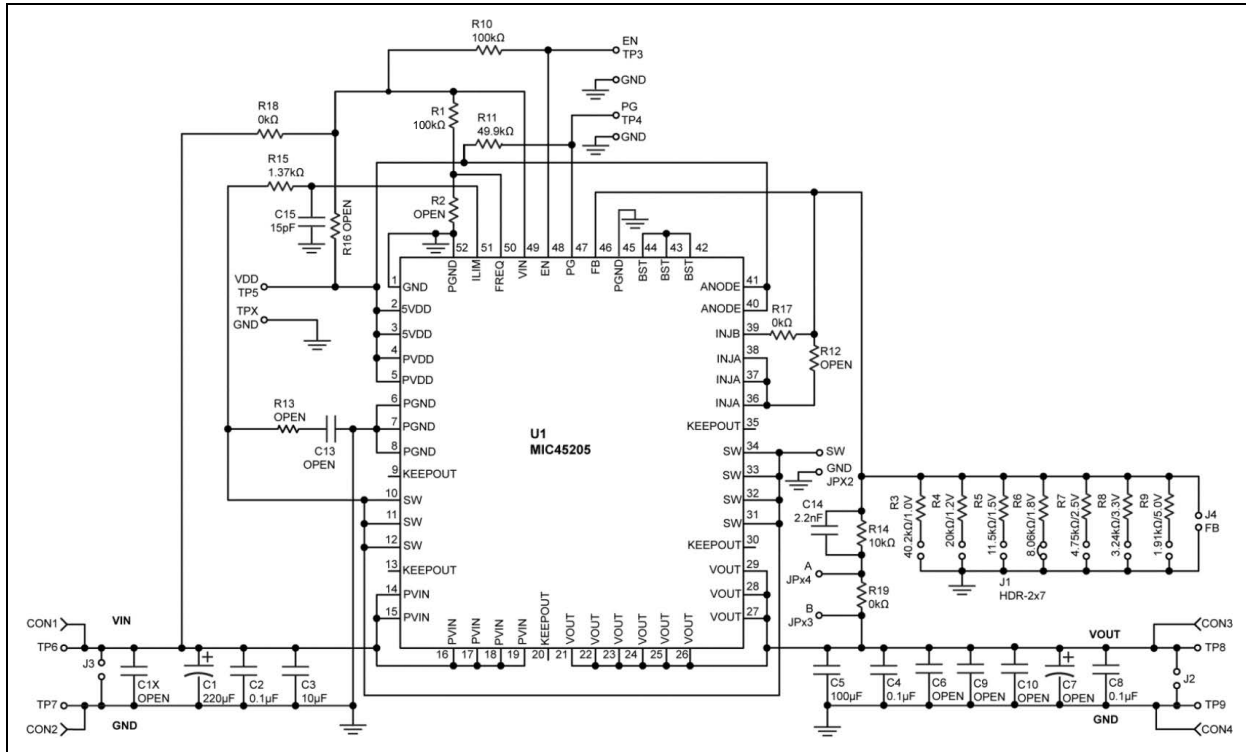


FIGURE 8-1: MIC45205YML Evaluation Board Schematic.

TABLE 8-1: BILL OF MATERIALS

Item	Part Number	Manufacturer	Description	Quantity
C1	EEE-FK1V221P	Panasonic	220 μF/35V, ALE Capacitor (optional)	1
C1X, C6, C9, C10, C7, C13	—	—	Open	6
C3	C3216X5R1H106M160AB	TDK	10 μF/50V, 1206, X5R, 10%, MLCC	1
C2, C4, C8	GRM188R71H104KA93D	Murata	0.1 μF/50V, X7R, 0603, 10%, MLCC	3
C5	C3216X5R0J107M160AB	TDK	100 μF/6.3V, X5R, 1206, 20%, MLCC	1
C14	C1608C0G1H222JT	TDK	2.2 nF/50V, NP0, 0603, 5%, MLCC	1
C11	GRM1885C1H150JA01D	Murata	15 pF/50V, NP0, 0603, 5%, MLCC	3
CON1, CON2, CON3, CON4	8174	Keystone	15A, 4-Prong Through-Hole Screw Terminal	4
J1	M50-3500742	Harwin	Header 2x7	1
J2, J3, J4, TP3 – TP5	90120-0122	Molex	Header 2	6
JPx1, JPx2	—	—	Open	2
R1, R10	CRCW0603100K0FKEA	Vishay Dale	100 kΩ, 1%, 1/10W, 0603, Thick Film	2
R2, R12, R13, R16	—	—	Open	4
R3	CRCW060340K2FKEA	Vishay Dale	40.2 kΩ, 1%, 1/10W, 0603, Thick Film	1
R4	CRCW060320K0FKEA	Vishay Dale	20 kΩ, 1%, 1/10W, 0603, Thick Film	1
R5	CRCW060311K5FKEA	Vishay Dale	11.5 kΩ, 1%, 1/10W, 0603, Thick Film	1
R6	CRCW06038K06FKEA	Vishay Dale	8.06 kΩ, 1%, 1/10W, 0603, Thick Film	1
R7	CRCW06034K75FKEA	Vishay Dale	4.75 kΩ, 1%, 1/10W, 0603, Thick Film	1

**TABLE 8-1: BILL OF MATERIALS (CONTINUED)**

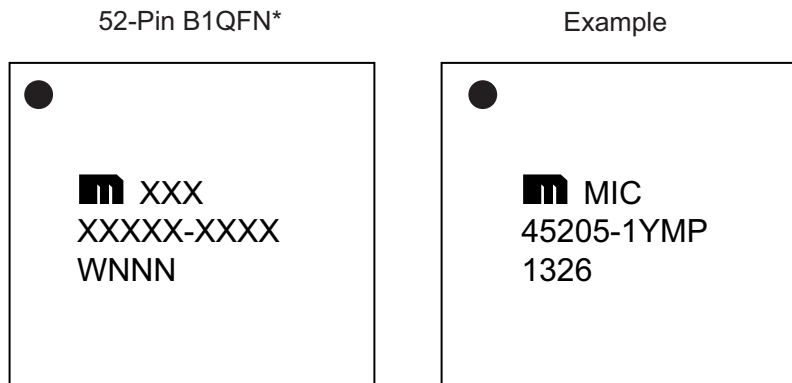
Item	Part Number	Manufacturer	Description	Quantity
R8	CRCW06033K24FKEA	Vishay Dale	3.24 k $\Omega$ , 1%, 1/10W, 0603, Thick Film	1
R9	CRCW06031K91FKEA	Vishay Dale	1.91 k $\Omega$ , 1%, 1/10W, 0603, Thick Film	1
R11	CRCW060349K9FKEA	Vishay Dale	49.9 k $\Omega$ , 1%, 1/10W, 0603, Thick Film	1
R14	CRCW060310K0FKEA	Vishay Dale	10 k $\Omega$ , 1%, 1/10W, 0603, Thick Film	1
R15	CRCW06031K37FKEA	Vishay Dale	1.37 k $\Omega$ , 1%, 1/10W, 0603, Thick Film	1
R17, R18, R19	RCG06030000Z0EA	Vishay Dale	0 $\Omega$ Resistor, 1%, 1/10W, 0603, Thick Film	3
TP6 – TP9, JPx3, JPx4	1502-2	Keystone	Single-End, Through-Hole Terminal	6
U1	MIC45205-1YMP	Microchip	26V/6A DC/DC Power Module	1
	MIC45205-2YMP			

# MIC45205

---

## 9.0 PACKAGING INFORMATION

### 9.1 Package Marking Information



<b>Legend:</b>	XX...X	Product code or customer-specific information
	Y	Year code (last digit of calendar year)
	YY	Year code (last 2 digits of calendar year)
	WW	Week code (week of January 1 is week '01')
	NNN	Alphanumeric traceability code
	(e3)	Pb-free JEDEC® designator for Matte Tin (Sn)
	*	This package is Pb-free. The Pb-free JEDEC designator (e3) can be found on the outer packaging for this package.
	•, ▲, ▼	Pin one index is identified by a dot, delta up, or delta down (triangle mark).
<b>Note:</b>	In the event the full Microchip part number cannot be marked on one line, it will be carried over to the next line, thus limiting the number of available characters for customer-specific information. Package may or may not include the corporate logo.	
	Underbar ( ¯ ) and/or Overbar ( ¯ ) symbol may not be to scale.	

**Note 1:** If the full seven-character YYWWNNN code cannot fit on the package, the following truncated codes are used based on the available marking space:  
6 Characters = YWWNNN; 5 Characters = WWNNN; 4 Characters = WNNN; 3 Characters = NNN;  
2 Characters = NN; 1 Character = N

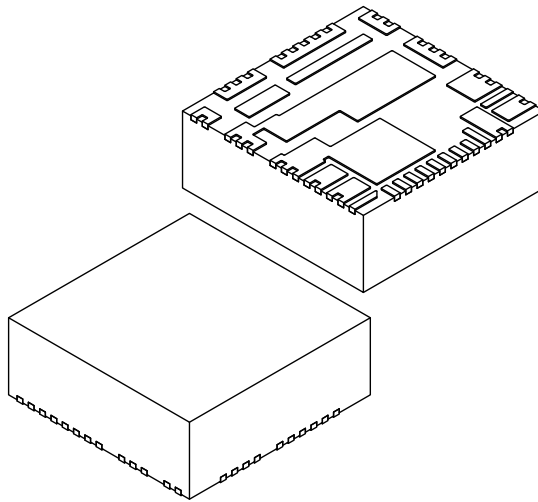


# MIC45205



## 52-Lead Very Thick Plastic Quad Flat, No Lead (M3A) - 8x8x3 mm Body [B1QFN] Micrel Legacy Package H3QFN88-52LD-PL-1

**Note:** For the most current package drawings, please see the Microchip Packaging Specification located at <http://www.microchip.com/packaging>



Dimension Limits	Units	MILLIMETERS		
		MIN	NOM	MAX
Number of Terminals	N	52		
Pitch	e	0.50 BSC		
Overall Height	A	–	–	3.00
Standoff	A1	0.00	0.02	0.05
Terminal Thickness	A3	0.20 REF		
Overall Length	D	8.00 BSC		
Overall Width	E	8.00 BSC		
Terminal Width	b	0.20	0.25	0.30

**Notes:**

1. Pin 1 visual index feature may vary, but must be located within the hatched area.
2. Package is saw singulated
3. BSC: Basic Dimension. Theoretically exact value shown without tolerances.

Microchip Technology Drawing C04-1055-M3A Rev A Sheet 2 of 2

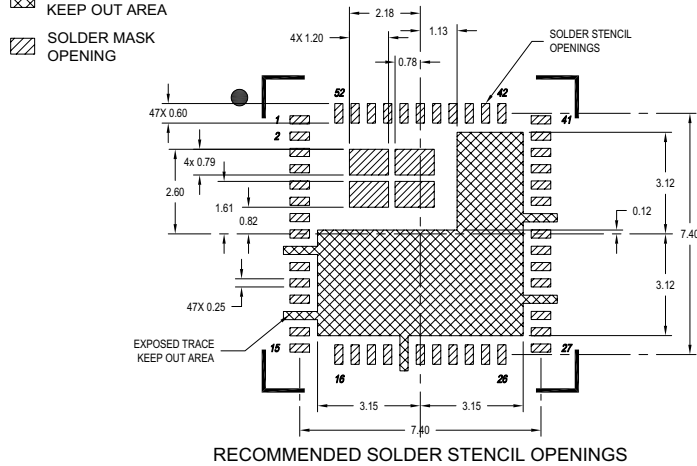
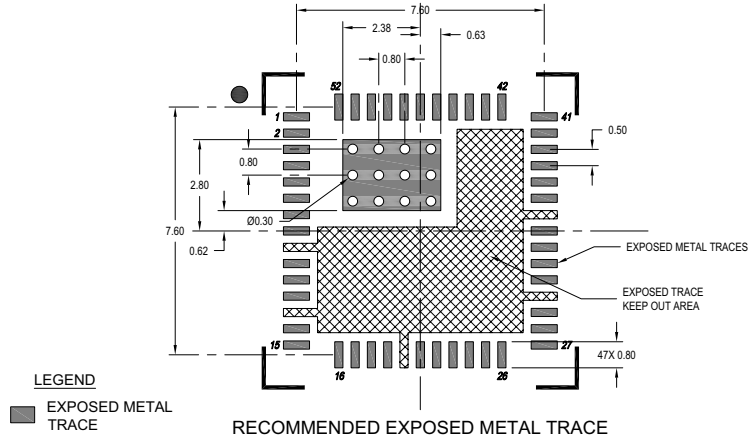
© 2021 Microchip Technology Incorporated





**52-Lead Very Thick Plastic Quad Flat, No Lead (M3A) - 8x8x3 mm Body [B1QFN]  
Micrel Legacy Package H3QFN88-52LD-PL-1**

**Note:** For the most current package drawings, please see the Microchip Packaging Specification located at <http://www.microchip.com/packaging>



**Notes:**

1. BSC: Basic Dimension. Theoretically exact value shown without tolerances.
2. For best soldering results, thermal vias, if used, should be filled or tented to avoid solder loss during reflow process

Microchip Technology Drawing C04-3055-M3A Rev A

# MIC45205

---

---

NOTES:

## APPENDIX A: REVISION HISTORY

### Revision A (June 2017)

- Converted Micrel document MIC45205 to Microchip data sheet DS20005798B.
- Minor text changes throughout.
- Updated maximum output voltage from 5.5V to  $0.85 \times V_{IN}$  in [Features](#) and [General Description](#).

### Revision B (May 2022)

- Corrected package marking drawings and added note below legend in Section 6.1, Package Marking Information.
- Corrected all instances of QFN and H3QFN to B1QFN and corrected package outline images from H3QFN to B1QFN outlines.
- Minor corrections to text, graphs, and equations where needed.

# MIC45205

---

---

NOTES:

## PRODUCT IDENTIFICATION SYSTEM

To order or obtain information, e.g., on pricing or delivery, contact your local Microchip representative or sales office.

<u>PART NO.</u>	<u>-X</u>	<u>X</u>	<u>XX</u>	<u>-XX</u>
Device	Features	Temperature	Package	Media Type
<b>Device:</b>	MIC45205:	26V/6A DC/DC Power Module		
<b>Features:</b>	1 =	HyperLight Load		
	2 =	Hyper Speed Control		
<b>Temperature:</b>	Y =	-40°C to +125°C		
<b>Package:</b>	MP =	52-Lead 8 mm x 8 mm x 3 mm B1QFN		
<b>Media Type:</b>	T1 =	100/Reel		
	TR =	1,500/Reel		

<b>Examples:</b>	
a) MIC45205-1YMP-T1:	26V/6A DC/DC Power Module, HyperLight Load, -40°C to +125°C, 52-Lead 8 mm x 8 mm x 3 mm B1QFN, 100/Reel
b) MIC45205-1YMP-TR:	26V/6A DC/DC Power Module, HyperLight Load, -40°C to +125°C, 52-Lead 8 mm x 8 mm x 3 mm B1QFN, 1,500/Reel
c) MIC45205-2YMP-T1:	26V/6A DC/DC Power Module, Hyper Speed Control, -40°C to +125°C, 52-Lead 8 mm x 8 mm x 3 mm B1QFN, 100/Reel
d) MIC45205-2YMP-TR:	26V/6A DC/DC Power Module, Hyper Speed Control, -40°C to +125°C, 52-Lead 8 mm x 8 mm x 3 mm B1QFN, 1,500/Reel

**Note 1:** Tape and Reel identifier only appears in the catalog part number description. This identifier is used for ordering purposes and is not printed on the device package. Check with your Microchip Sales Office for package availability with the Tape and Reel option.

# MIC45205

---

---

NOTES:

---

---

**Note the following details of the code protection feature on Microchip products:**

- Microchip products meet the specifications contained in their particular Microchip Data Sheet.
- Microchip believes that its family of products is secure when used in the intended manner, within operating specifications, and under normal conditions.
- Microchip values and aggressively protects its intellectual property rights. Attempts to breach the code protection features of Microchip product is strictly prohibited and may violate the Digital Millennium Copyright Act.
- Neither Microchip nor any other semiconductor manufacturer can guarantee the security of its code. Code protection does not mean that we are guaranteeing the product is “unbreakable”. Code protection is constantly evolving. Microchip is committed to continuously improving the code protection features of our products.

---

This publication and the information herein may be used only with Microchip products, including to design, test, and integrate Microchip products with your application. Use of this information in any other manner violates these terms. Information regarding device applications is provided only for your convenience and may be superseded by updates. It is your responsibility to ensure that your application meets with your specifications. Contact your local Microchip sales office for additional support or, obtain additional support at <https://www.microchip.com/en-us/support/design-help/client-support-services>.

THIS INFORMATION IS PROVIDED BY MICROCHIP "AS IS". MICROCHIP MAKES NO REPRESENTATIONS OR WARRANTIES OF ANY KIND WHETHER EXPRESS OR IMPLIED, WRITTEN OR ORAL, STATUTORY OR OTHERWISE, RELATED TO THE INFORMATION INCLUDING BUT NOT LIMITED TO ANY IMPLIED WARRANTIES OF NON-INFRINGEMENT, MERCHANTABILITY, AND FITNESS FOR A PARTICULAR PURPOSE, OR WARRANTIES RELATED TO ITS CONDITION, QUALITY, OR PERFORMANCE.

IN NO EVENT WILL MICROCHIP BE LIABLE FOR ANY INDIRECT, SPECIAL, PUNITIVE, INCIDENTAL, OR CONSEQUENTIAL LOSS, DAMAGE, COST, OR EXPENSE OF ANY KIND WHATSOEVER RELATED TO THE INFORMATION OR ITS USE, HOWEVER CAUSED, EVEN IF MICROCHIP HAS BEEN ADVISED OF THE POSSIBILITY OR THE DAMAGES ARE FORESEEABLE. TO THE FULLEST EXTENT ALLOWED BY LAW, MICROCHIP'S TOTAL LIABILITY ON ALL CLAIMS IN ANY WAY RELATED TO THE INFORMATION OR ITS USE WILL NOT EXCEED THE AMOUNT OF FEES, IF ANY, THAT YOU HAVE PAID DIRECTLY TO MICROCHIP FOR THE INFORMATION.

Use of Microchip devices in life support and/or safety applications is entirely at the buyer's risk, and the buyer agrees to defend, indemnify and hold harmless Microchip from any and all damages, claims, suits, or expenses resulting from such use. No licenses are conveyed, implicitly or otherwise, under any Microchip intellectual property rights unless otherwise stated.

For information regarding Microchip's Quality Management Systems, please visit [www.microchip.com/quality](http://www.microchip.com/quality).

**Trademarks**

The Microchip name and logo, the Microchip logo, Adaptec, AnyRate, AVR, AVR logo, AVR Freaks, BesTime, BitCloud, CryptoMemory, CryptoRF, dsPIC, flexPWR, HELDO, IGLOO, JukeBlox, KeeLoq, Kleer, LANCheck, LinkMD, maXStylus, maXTouch, MediaLB, megaAVR, Microsemi, Microsemi logo, MOST, MOST logo, MPLAB, OptoLyzr, PIC, picoPower, PICSTART, PIC32 logo, PolarFire, Prochip Designer, QTouch, SAM-BA, SenGenuity, SpyNIC, SST, SST Logo, SuperFlash, Symmetricom, SyncServer, Tachyon, TimeSource, tinyAVR, UNI/O, Vectron, and XMEGA are registered trademarks of Microchip Technology Incorporated in the U.S.A. and other countries.

AgileSwitch, APT, ClockWorks, The Embedded Control Solutions Company, EtherSynch, Flashtec, Hyper Speed Control, HyperLight Load, IntelliMOS, Libero, motorBench, mTouch, Powermite 3, Precision Edge, ProASIC, ProASIC Plus, ProASIC Plus logo, QuietWire, SmartFusion, SyncWorld, Temux, TimeCesium, TimeHub, TimePictra, TimeProvider, TrueTime, WinPath, and ZL are registered trademarks of Microchip Technology Incorporated in the U.S.A.

Adjacent Key Suppression, AKS, Analog-for-the-Digital Age, Any Capacitor, AnyIn, AnyOut, Augmented Switching, BlueSky, BodyCom, CodeGuard, CryptoAuthentication, CryptoAutomotive, CryptoCompanion, CryptoController, dsPICDEM, dsPICDEM.net, Dynamic Average Matching, DAM, ECAN, Espresso T1S, EtherGREEN, GridTime, IdealBridge, In-Circuit Serial Programming, ICSP, INICnet, Intelligent Paralleling, Inter-Chip Connectivity, JitterBlocker, Knob-on-Display, maxCrypto, maxView, memBrain, Mindi, MiWi, MPASM, MPF, MPLAB Certified logo, MPLIB, MPLINK, MultiTRAK, NetDetach, NVM Express, NVMe, Omniscient Code Generation, PICDEM, PICDEM.net, PICkit, PICtail, PowerSmart, PureSilicon, QMatrix, REAL ICE, Ripple Blocker, RTAX, RTG4, SAM-ICE, Serial Quad I/O, simpleMAP, SimpliPHY, SmartBuffer, SmartHLS, SMART-I.S., storClad, SQL, SuperSwitcher, SuperSwitcher II, Switchtec, SynchroPHY, Total Endurance, TSHARC, USBCheck, VariSense, VectorBlox, VeriPHY, ViewSpan, WiperLock, XpressConnect, and ZENA are trademarks of Microchip Technology Incorporated in the U.S.A. and other countries.

SQTP is a service mark of Microchip Technology Incorporated in the U.S.A.

The Adaptec logo, Frequency on Demand, Silicon Storage Technology, Symmcom, and Trusted Time are registered trademarks of Microchip Technology Inc. in other countries.

GestIC is a registered trademark of Microchip Technology Germany II GmbH & Co. KG, a subsidiary of Microchip Technology Inc., in other countries.

All other trademarks mentioned herein are property of their respective companies.

© 2017 - 2022, Microchip Technology Incorporated and its subsidiaries.

All Rights Reserved.

ISBN: 978-1-6683-0375-7



# MICROCHIP

## Worldwide Sales and Service

### AMERICAS

**Corporate Office**  
2355 West Chandler Blvd.  
Chandler, AZ 85224-6199  
Tel: 480-792-7200  
Fax: 480-792-7277  
Technical Support:  
[http://www.microchip.com/  
support](http://www.microchip.com/support)  
Web Address:  
[www.microchip.com](http://www.microchip.com)

**Atlanta**  
Duluth, GA  
Tel: 678-957-9614  
Fax: 678-957-1455

**Austin, TX**  
Tel: 512-257-3370

**Boston**  
Westborough, MA  
Tel: 774-760-0087  
Fax: 774-760-0088

**Chicago**  
Itasca, IL  
Tel: 630-285-0071  
Fax: 630-285-0075

**Dallas**  
Addison, TX  
Tel: 972-818-7423  
Fax: 972-818-2924

**Detroit**  
Novi, MI  
Tel: 248-848-4000

**Houston, TX**  
Tel: 281-894-5983

**Indianapolis**  
Noblesville, IN  
Tel: 317-773-8323  
Fax: 317-773-5453  
Tel: 317-536-2380

**Los Angeles**  
Mission Viejo, CA  
Tel: 949-462-9523  
Fax: 949-462-9608  
Tel: 951-273-7800

**Raleigh, NC**  
Tel: 919-844-7510

**New York, NY**  
Tel: 631-435-6000

**San Jose, CA**  
Tel: 408-735-9110  
Tel: 408-436-4270

**Canada - Toronto**  
Tel: 905-695-1980  
Fax: 905-695-2078

### ASIA/PACIFIC

**Australia - Sydney**  
Tel: 61-2-9868-6733

**China - Beijing**  
Tel: 86-10-8569-7000

**China - Chengdu**  
Tel: 86-28-8665-5511

**China - Chongqing**  
Tel: 86-23-8980-9588

**China - Dongguan**  
Tel: 86-769-8702-9880

**China - Guangzhou**  
Tel: 86-20-8755-8029

**China - Hangzhou**  
Tel: 86-571-8792-8115

**China - Hong Kong SAR**  
Tel: 852-2943-5100

**China - Nanjing**  
Tel: 86-25-8473-2460

**China - Qingdao**  
Tel: 86-532-8502-7355

**China - Shanghai**  
Tel: 86-21-3326-8000

**China - Shenyang**  
Tel: 86-24-2334-2829

**China - Shenzhen**  
Tel: 86-755-8864-2200

**China - Suzhou**  
Tel: 86-186-6233-1526

**China - Wuhan**  
Tel: 86-27-5980-5300

**China - Xian**  
Tel: 86-29-8833-7252

**China - Xiamen**  
Tel: 86-592-2388138

**China - Zhuhai**  
Tel: 86-756-3210040

### ASIA/PACIFIC

**India - Bangalore**  
Tel: 91-80-3090-4444

**India - New Delhi**  
Tel: 91-11-4160-8631

**India - Pune**  
Tel: 91-20-4121-0141

**Japan - Osaka**  
Tel: 81-6-6152-7160

**Japan - Tokyo**  
Tel: 81-3-6880-3770

**Korea - Daegu**  
Tel: 82-53-744-4301

**Korea - Seoul**  
Tel: 82-2-554-7200

**Malaysia - Kuala Lumpur**  
Tel: 60-3-7651-7906

**Malaysia - Penang**  
Tel: 60-4-227-8870

**Philippines - Manila**  
Tel: 63-2-634-9065

**Singapore**  
Tel: 65-6334-8870

**Taiwan - Hsin Chu**  
Tel: 886-3-577-8366

**Taiwan - Kaohsiung**  
Tel: 886-7-213-7830

**Taiwan - Taipei**  
Tel: 886-2-2508-8600

**Thailand - Bangkok**  
Tel: 66-2-694-1351

**Vietnam - Ho Chi Minh**  
Tel: 84-28-5448-2100

### EUROPE

**Austria - Wels**  
Tel: 43-7242-2244-39  
Fax: 43-7242-2244-393

**Denmark - Copenhagen**  
Tel: 45-4485-5910  
Fax: 45-4485-2829

**Finland - Espoo**  
Tel: 358-9-4520-820

**France - Paris**  
Tel: 33-1-69-53-63-20  
Fax: 33-1-69-30-90-79

**Germany - Garching**  
Tel: 49-8931-9700

**Germany - Haan**  
Tel: 49-2129-3766400

**Germany - Heilbronn**  
Tel: 49-7131-72400

**Germany - Karlsruhe**  
Tel: 49-721-625370

**Germany - Munich**  
Tel: 49-89-627-144-0  
Fax: 49-89-627-144-44

**Germany - Rosenheim**  
Tel: 49-8031-354-560

**Israel - Ra'anana**  
Tel: 972-9-744-7705

**Italy - Milan**  
Tel: 39-0331-742611  
Fax: 39-0331-466781

**Italy - Padova**  
Tel: 39-049-7625286

**Netherlands - Drunen**  
Tel: 31-416-690399  
Fax: 31-416-690340

**Norway - Trondheim**  
Tel: 47-7288-4388

**Poland - Warsaw**  
Tel: 48-22-3325737

**Romania - Bucharest**  
Tel: 40-21-407-87-50

**Spain - Madrid**  
Tel: 34-91-708-08-90  
Fax: 34-91-708-08-91

**Sweden - Gothenberg**  
Tel: 46-31-704-60-40

**Sweden - Stockholm**  
Tel: 46-8-5090-4654

**UK - Wokingham**  
Tel: 44-118-921-5800  
Fax: 44-118-921-5820