



MIC2172/3172

100kHz 1.25A Switching Regulators

General Description

The MIC2172 and MIC3172 are complete 100kHz SMPS current-mode controllers with internal 65V 1.25A power switches. The MIC2172 features external frequency synchronization or frequency adjustment, while the MIC3172 features an enable/shutdown control input.

Although primarily intended for voltage step-up applications, the floating switch architecture of the MIC2172/3172 makes it practical for step-down, inverting, and Cuk configurations as well as isolated topologies.

Operating from 3V to 40V, the MIC2172/3172 draws only 7mA of quiescent current making it attractive for battery operated supplies.

The MIC3172 is for applications that require on/off control of the regulator. The MIC3172 is externally shutdown by applying a TTL low signal to EN (enable). When disabled, the MIC3172 draws only leakage current (typically less than 1 μ A). EN must be high for normal operation. For applications not requiring control, EN must be tied to V_{IN} or TTL high.

The MIC2172 is for applications requiring two or more SMPS regulators that operate from the same input supply. The MIC2172 features a SYNC input which allows locking of its internal oscillator to an external reference. This makes it possible to avoid the audible beat frequencies that result from the unequal oscillator frequencies of independent SMPS regulators.

A reference signal can be supplied by one MIC2172 designated as a master. To insure locking of the slave's oscillators, the reference oscillator frequency must be higher than the slave's. The master MIC2172's oscillator frequency is increased up to 135kHz by connecting a resistor from SYNC to ground (see applications information).

The MIC2172/3172 is available in an 8-pin plastic DIP or SOIC for -40°C to +85°C operation.

Features

- 1.25A, 65V internal switch rating
- 3V to 40V input voltage range
- Current-mode operation
- Internal cycle-by-cycle current limit
- Thermal shutdown
- Low external parts count
- Operates in most switching topologies
- 7mA quiescent current (operating)
- <1 μ A quiescent current, shutdown mode (MIC3172)
- TTL shutdown compatibility (MIC3172)
- External frequency synchronization (MIC2172)
- External frequency trim (MIC2172)
- Fits most LT1172 sockets (see applications info)

Applications

- Laptop/palmtop computers
- Toys
- Hand-held instruments
- Off-line converter up to 50W (requires external power switch)
- Predriver for higher power capability
- Master/slave configurations (MIC2172)

Typical Applications

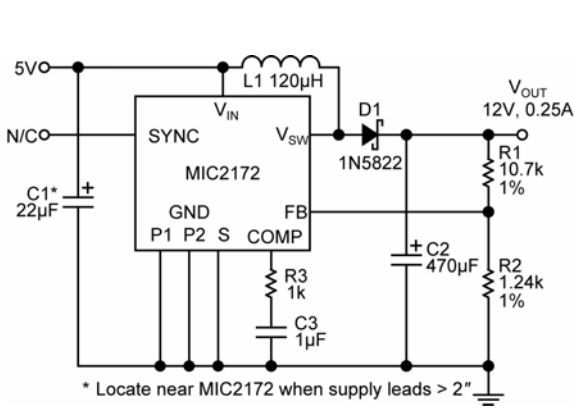

Figure 1. MIC2172 5V to 12V Boost Converter

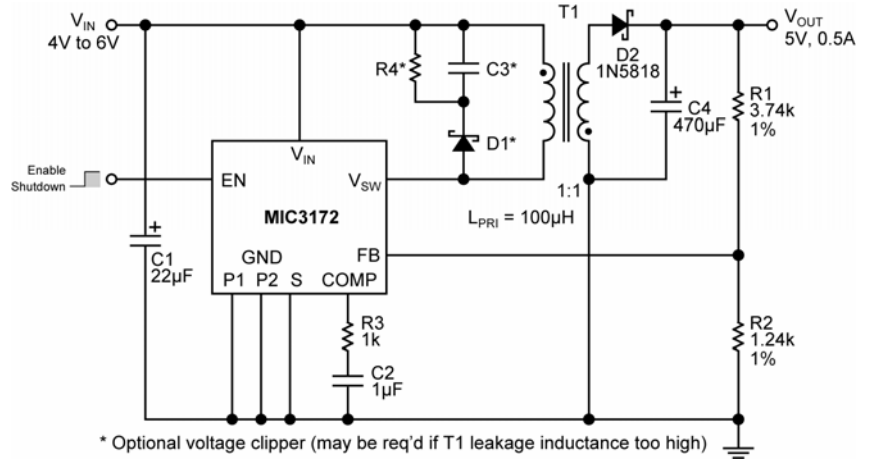

Figure 2. MIC3172 Flyback Converter

Ordering Information

Part Number		Junction Temp. Range	Package
Standard	Pb-Free		
MIC2172BN	MIC2172YN	-40°C to +85°C	8-pin plastic DIP
MIC2172BM	MIC2172YM	-40°C to +85°C	8-pin SOIC
MIC3172BN	MIC3172YN	-40°C to +85°C	8-pin plastic DIP
MIC3172BM	MIC3172YM	-40°C to +85°C	8-pin SOIC

Note:

1. Other Voltage available. Contact Micrel for details.

Pin Configuration

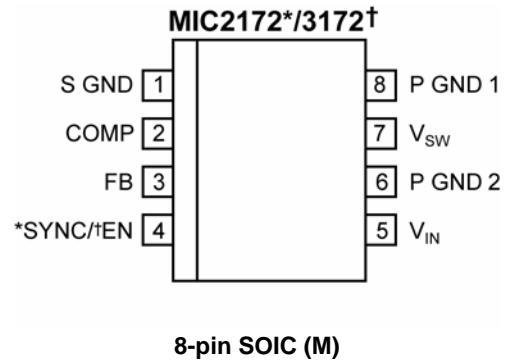
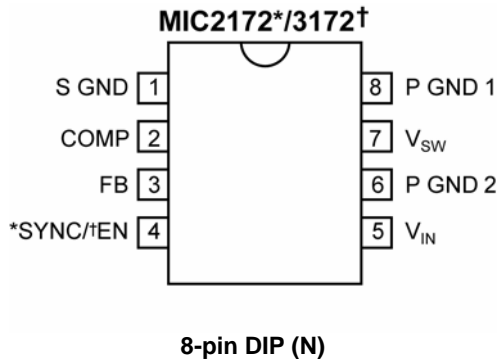

Pin Description

Pin Number	Pin Name	Pin Function
1	S GND	Signal Ground: Internal analog circuit ground. Connect directly to the input filter capacitor for proper operation (see applications info). Keep separate from power grounds.
2	COMP	Frequency Compensation: Output of transconductance type error amplifier. Primary function is for loop stabilization. Can also be used for output voltage soft-start and current limit tailoring.
3	FB	Feedback: Inverting input of error amplifier. Connect to external resistive divider to set power supply output voltage.
4 (MIC2172)	SYNC	Synchronization/Frequency Adjust: Capacitively coupled input signal greater than device's free running frequency (up to 135kHz) will lock device's oscillator on falling edge. Oscillator frequency can be trimmed up to 135kHz by adding a resistor to ground. If unused, pin must float (no connection).
4 (MIC3172)	EN	Enable: Apply TTL high or connect to V_{IN} to enable the regulator. Apply TTL low or connect to ground to disable the regulator. Device draws only leakage current ($<1\mu A$) when disabled.
5	V_{IN}	Supply Voltage: 3.0V to 40V
6	P GND 2	Power Ground #2: One of two NPN power switch emitters with 0.3Ω current sense resistor in series. Required. Connect to external inductor or input voltage ground depending on circuit topology.
7	VSW	Power Switch Collector: Collector of NPN switch. Connect to external inductor or input voltage depending on circuit topology.
8	P GND 1	Power Ground #1: One of two NPN power switch emitters with 0.3Ω current sense resistor in series. Optional. For maximum power capability connect to P GND 2. Floating pin reduces current limit by a factor of two.

Absolute Maximum Ratings MIC2172

Input Voltage.....	40V	Junction Temperature.....	-55°C to +150°C
Switch Voltage.....	65V	Thermal Resistance	
Sync Current.....	50mA	θ_{JA} 8-pin PDIP.....	130°C/W
Feedback Voltage (Transient, 1ms).....	±15V	θ_{JA} 8-pin SOIC.....	120°C/W
Operating Temperature Range		Storage Temperature.....	-65°C to +150°C
8-pin PDIP.....	-40 to +85°C	Soldering (10 sec.).....	+300°C
8-pin SOIC.....	-40 to +85°C		

Electrical Characteristics MIC2172

Note 1, 3. Unless otherwise specified, $V_{IN} = 5V$.

Parameter	Condition	Min	Typ	Max	Units
Reference Section					
Pin 2 tied to pin 3					
Feedback Voltage (V_{FB})		1.220 1.214	1.240	1.264 1.274	V V
Feedback Voltage Line Regulation	$3V \leq V_{IN} \leq 40V$			0.03	%/V
Feedback Bias Current (I_{FB})			310	750 1100	nA nA
Error Amplifier Section					
Transconductance ($\Delta I_{COMP}/\Delta V_{FB}$)	$\Delta I_{COMP} = \pm 25\mu A$	3.0 2.4	3.9	6.0 7.0	$\mu A/mV$ $\mu A/mV$
Voltage Gain ($\Delta V_{COMP}/\Delta V_{FB}$)	$0.9V \leq V_{COMP} \leq 1.4V$	500	800	2000	V/V
Output Current	$V_{COMP} = 1.5V$	125 100	175	350 400	μA μA
Output Swing	High Clamp, $V_{FB} = 1V$ Low Clamp, $V_{FB} = 1.5V$	1.8 0.25	2.1 0.35	2.3 0.52	V V
Compensation Pin Threshold	Duty Cycle = 0	0.8 0.6	0.9	1.08 1.25	V V
Output Switch Section					
ON Resistance	$I_{SW} = 1A, V_{FB} = 0.8V$		0.76	1 1.1	Ω Ω
Current Limit	Duty Cycle = 50%, $T_J \geq 25^\circ C$ Duty Cycle = 50%, $T_J < 25^\circ C$ Duty Cycle = 80%, Note 2	1.25 1.25 1		3 3.5 2.5	A A A
Breakdown Voltage (BV)	$3V \leq V_{IN} \leq 40V$ $I_{SW} = 5mA$	65	75		V

Notes:

1. Exceeding the absolute maximum rating may damage the device.
2. The device is not guaranteed to function outside its operating rating.
3. Devices are ESD sensitive. Handling precautions recommended. Human body model, 1.5k in series with 100pF.
4. Specification for packaged product only.

Typical Characteristics MIC2172 (cont)

Parameter	Condition	Min	Typ	Max	Units
Oscillator Section					
Frequency (f_o)		88 85	100	112 115	kHz kHz
Duty Cycle [δ (max)]		80	89	95	%
Sync Coupling Capacitor Required for Frequency Lock	$V_{PP} = 3.0V$ $V_{PP} = 40V$	22 2.2	51 4.7	120 10	μF μF
Input Supply Voltage Section					
Minimum Operating Voltage			2.7	3.0	V
Quiescent Current (I_Q)	$3V \leq V_{IN} \leq 40V$, $V_{COMP} = 0.6V$, $I_{SW} = 0$		7	9	mA
Supply Current Increase (ΔI_{IN})	$\Delta I_{SW} = 1A$, $V_{COMP} = 1.5V$		9	20	mA

Electrical Characteristics MIC3172

Note 1, 3. Unless otherwise specified, $V_{IN} = 5V$.

Parameter	Condition	Min	Typ	Max	Units
Reference Section					
Pin 2 tied to pin 3					
Feedback Voltage (V_{FB})		1.224 1.214	1.240	1.264 1.274	V V
Feedback Voltage Line Regulation	$3V \leq V_{IN} \leq 40V$		0.07		%/V
Feedback Bias Current (I_{FB})			310	750 1100	nA nA
Error Amplifier Section					
Transconductance ($\Delta I_{COMP}/\Delta V_{FB}$)	$\Delta I_{COMP} = \pm 25\mu A$	3.0 2.4	3.9	6.0 7.0	$\mu A/mV$ $\mu A/mV$
Voltage Gain ($\Delta V_{COMP}/\Delta V_{FB}$)	$0.9V \leq V_{COMP} \leq 1.4V$	500	800	2000	V/V
Output Current	$V_{COMP} = 1.5V$	125 100	175	350 400	μA μA
Output Swing	High Clamp, $V_{FB} = 1V$ Low Clamp, $V_{FB} = 1.5V$	1.8 0.25	2.1 0.35	2.3 0.52	V V
Compensation Pin Threshold	Duty Cycle = 0	0.8 0.6	0.9	1.08 1.25	V V
Output Switch Section					
ON Resistance	$I_{SW} = 1A$, $V_{FB} = 0.8V$		0.76	1 1.1	Ω Ω
Current Limit	Duty Cycle = 50%, $T_J \geq 25^\circ C$ Duty Cycle = 50%, $T_J < 25^\circ C$ Duty Cycle = 80%, Note 2	1.25 1.25 1		3 3.5 2.5	A A A
Breakdown Voltage (BV)	$3V \leq V_{IN} \leq 40V$ $I_{SW} = 5mA$	65	75		V

Typical Characteristics MIC3172 (cont)

Parameter	Condition	Min	Typ	Max	Units
Oscillator Section					
Frequency (f_o)		88 85	100	112 115	kHz kHz
Duty Cycle [δ (max)]		80	89	95	%
Sync Coupling Capacitor Required for Frequency Lock	$V_{PP} = 3.0V$ $V_{PP} = 40V$	22 2.2	51 4.7	120 10	pF pF
Input Supply Voltage Section and Enable Section					
Minimum Operating Voltage			2.7	3.0	V
Quiescent Current (I_Q)	$3V \leq V_{IN} \leq 40V$, $V_{COMP} = 0.6V$, $I_{SW} = 0$		7	9	mA
Supply Current Increase (ΔI_{IN})	$\Delta I_{SW} = 1A$, $V_{COMP} = 1.5V$		9	20	mA
Enable Input Threshold		0.4	1.2	2.4	V
Enable Input Current	$V_{EN} = 0V$ $V_{EN} = 2.4V$	-1	0 2	1 10	μA μA

Bold type denotes specifications applicable to the full operating temperature range.

Note 1. Devices are ESD sensitive. Handling precautions required.

Note 2. For duty cycles (δ) between 50% and 95%, minimum guaranteed switch current is given by $I_{CL} = 0.833 (2 - \delta)$ for the MIC3172.

Note 3. Specification for packaged product only.

Typical Characteristics

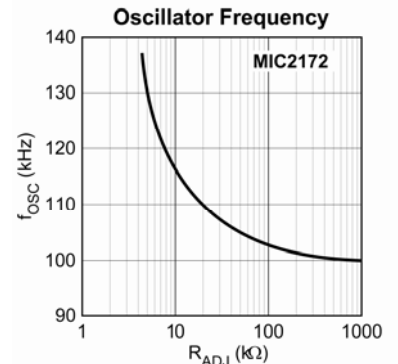
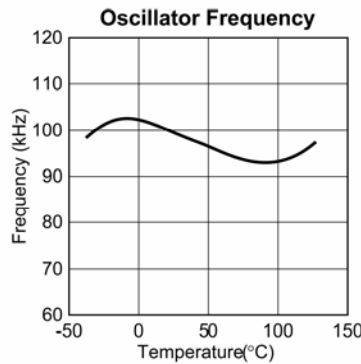
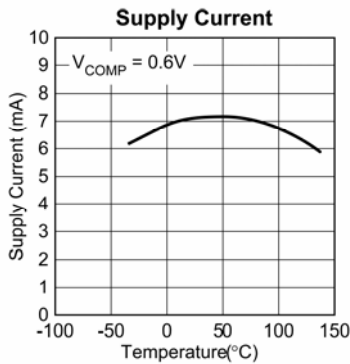
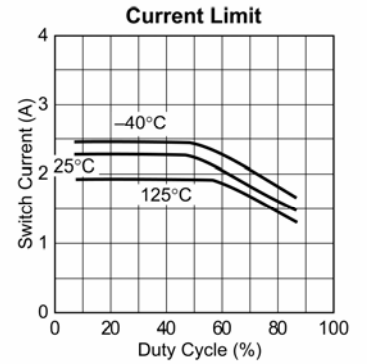
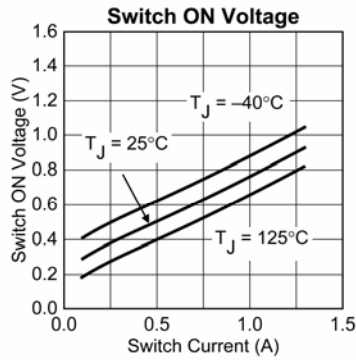
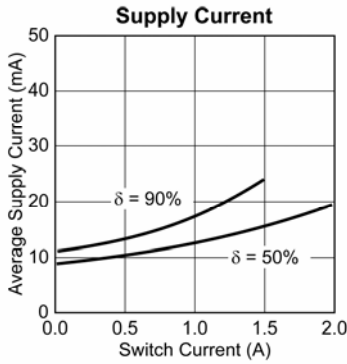
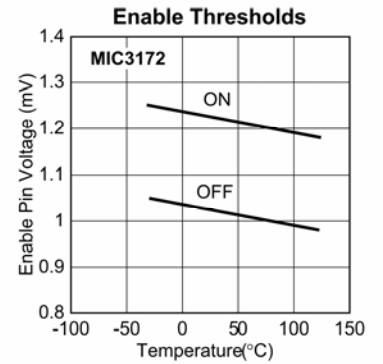
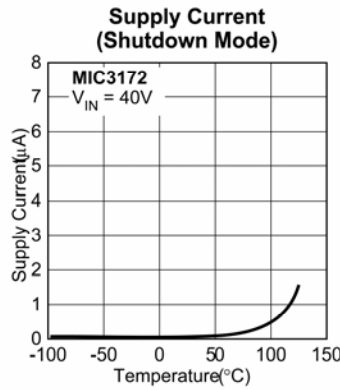
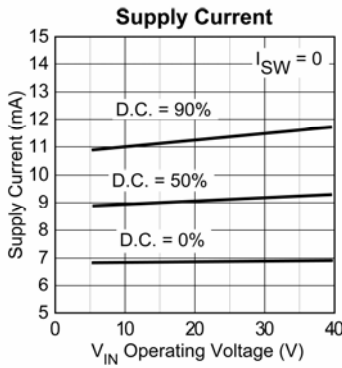
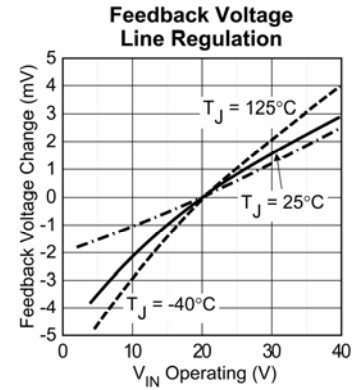
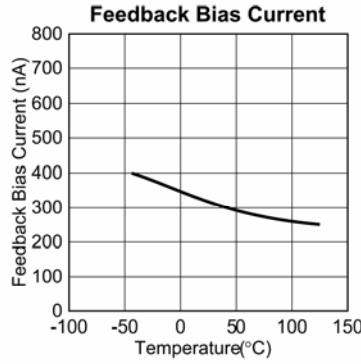
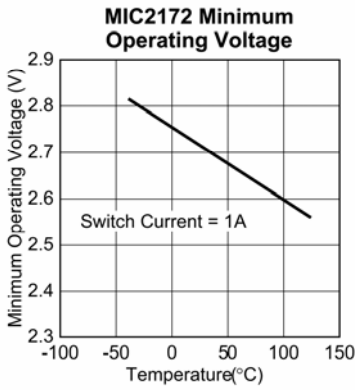

Typical Characteristics (cont.)

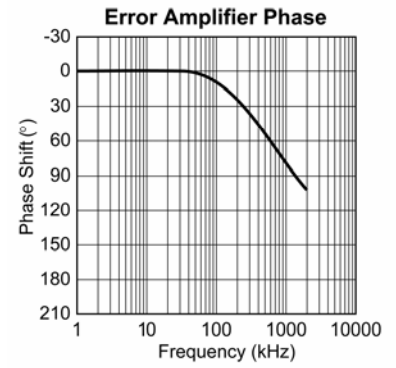
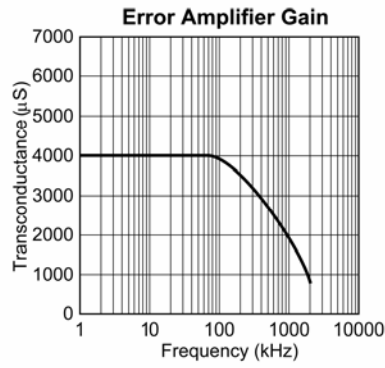
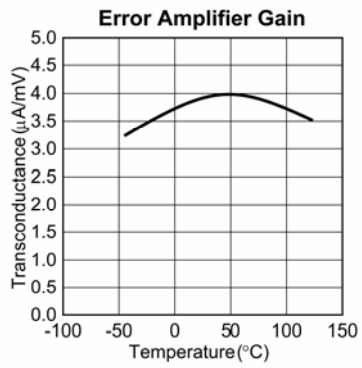

Functional Characteristics

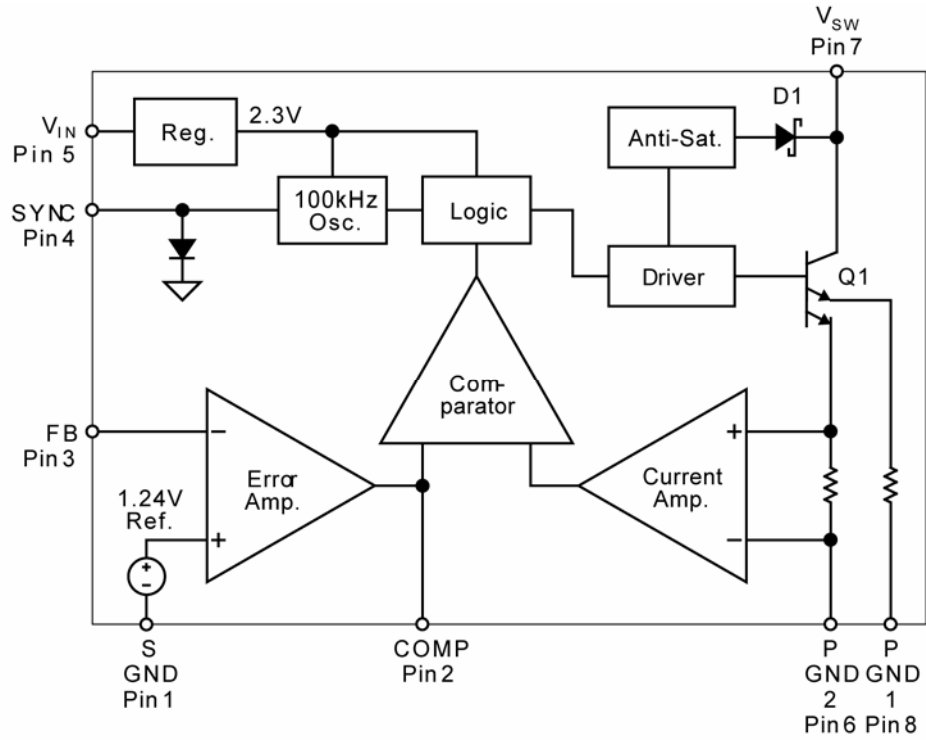

MIC2172 Block Diagram

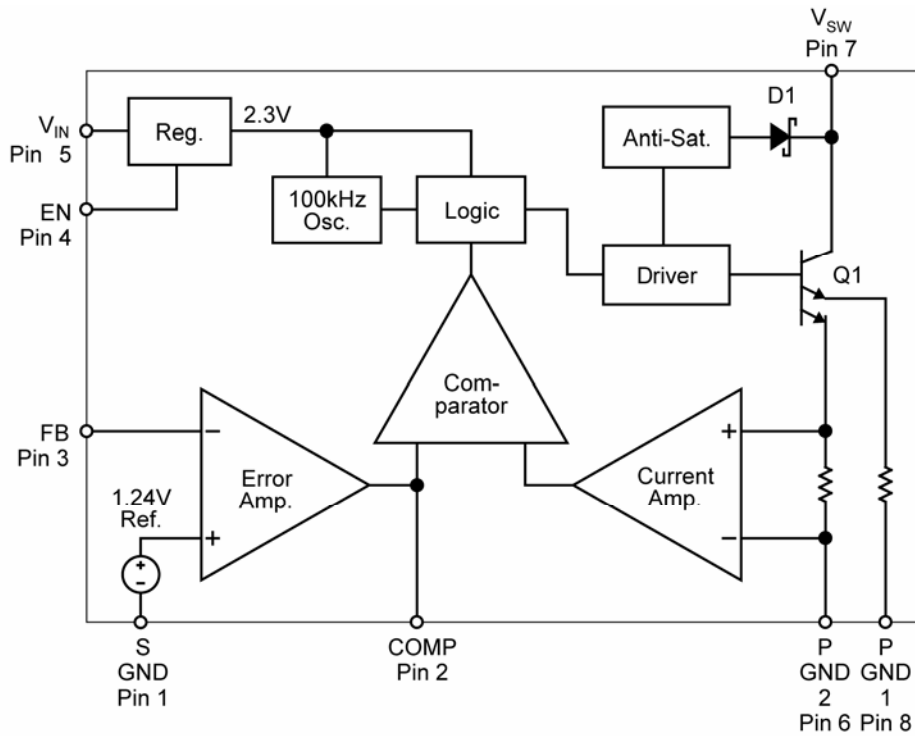

MIC3172 Block Diagram

Functional Description

Refer to “Block Diagram MIC2172” and “Block Diagram MIC3172.”

Internal Power

The MIC2172/3172 operates when V_{IN} is $\geq 2.6V$ (and $V_{EN} \geq 2.0V$ for the MIC3172). An internal 2.3V regulator supplies biasing to all internal circuitry including a precision 1.24V band gap reference.

The enable control (MIC3172 only) enables or disables the internal regulator which supplies power to all other internal circuitry.

PWM Operation

The 100kHz oscillator generates a signal with a duty cycle of approximately 90%. The current-mode comparator output is used to reduce the duty cycle when the current amplifier output voltage exceeds the error amplifier output voltage. The resulting PWM signal controls a driver which supplies base current to output transistor Q1.

Current Mode Advantages

The MIC2172/3172 operates in current mode rather than voltage mode. There are three distinct advantages to this technique. Feedback loop compensation is greatly

simplified because inductor current sensing removes a pole from the closed loop response. Inherent cycle-by-cycle current limiting greatly improves the power switch reliability and provides automatic output current limiting. Finally, current-mode operation provides automatic input voltage feed forward which prevents instantaneous input voltage changes from disturbing the output voltage setting.

Anti-Saturation

The anti-saturation diode (D1) increases the usable duty cycle range of the MIC2172/3172 by eliminating the base to collector stored charge which would delay Q1's turnoff.

Compensation

Loop stability compensation of the MIC2172/3172 can be accomplished by connecting an appropriate network from either COMP to circuit ground (Typical Applications) or COMP to FB.

The error amplifier output (COMP) is also useful for soft start and current limiting. Because the error amplifier output is a transconductance type, the output impedance is relatively high which means the output voltage can be easily clamped or adjusted externally.

Application Information

Using the MIC3172 Enable Control (New Designs)

For new designs requiring enable/shutdown control, connect EN to a TTL or CMOS control signal (figure 3). The very low driver current requirement ensures compatibility regardless of the driver or gate used.

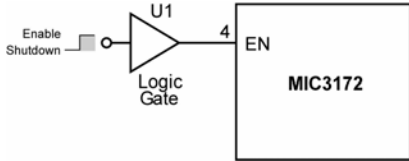

Figure 3. MIC3172 TTL Enable/Shutdown

Using the MIC3172 in LT1172 Applications

The MIC3172 can be used in most original LT1172 applications by adapting the MIC3172's enable/shutdown feature to the existing LT1172 circuit.

Unlike the LT1172 which can be shutdown by reducing the voltage on pin 2 (V_C) below 0.15V, the MIC3172 has a dedicated enable/shutdown pin. To replace the LT1172 with the MIC3172, determine if the LT1172's shutdown feature is used.

Circuits without Shutdown

If the shutdown feature is not being used, connect EN to V_{IN} to continuously enable the MIC3172 or use an MIC2172 with SYNC open (figure 4).

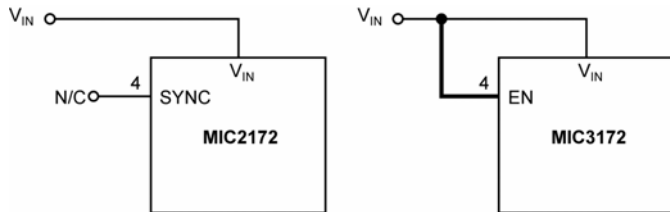

Figure 4. MIC2172/3172 Always Enabled

Circuits with Shutdown

If shutdown was used in the original LT1172 application, connect EN to a logic gate that produces a TTL logic-level output signal that matches the shutdown signal. The MIC3172 will be enabled by a logic-high input and shutdown with a logic-low input (figure 5). The actual components performing the functions of U1 and Q1 may vary according to the original application.

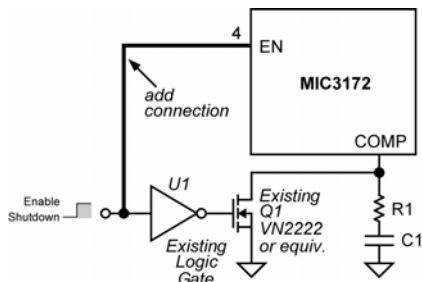

Figure 5. Adapting to the LT1172 Socket

By using the MIC3172, U1 and Q1 shown in figure 5 can be eliminated, reducing the total components count.

Synchronizing the MIC2172

Using several unsynchronized switching regulators in the same circuit will cause beat frequencies to appear on the inputs and outputs. These beat frequencies can be very low making them difficult to filter.

Micrel's MIC2172 can be synchronized to a single master frequency avoiding the possibility of undesirable beat frequencies in multiple regulator circuits. The master frequency can be an external oscillator or a designated master MIC2172. The master frequency should be 1.05 to 1.20 times the slave's 100kHz nominal frequency to guarantee synchronization.

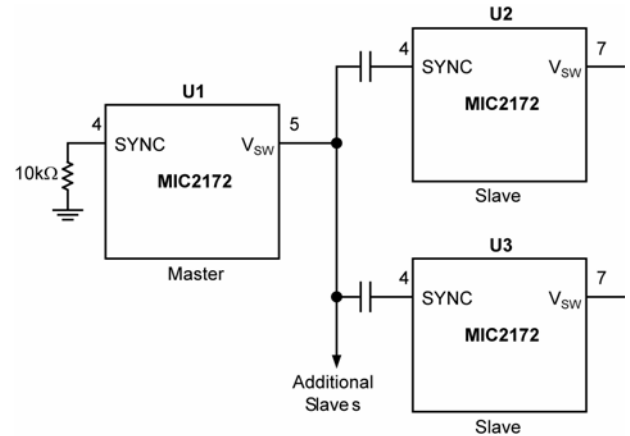

Figure 6. Master/Slave Synchronization

Figure 6 shows a typical application where several MIC2172s operate from the same supply voltage. U1's oscillator frequency is increased above U2's and U3's by connecting a resistor from SYNC to ground. U2-SYNC and U3-SYNC are capacitively coupled to the master's output (V_{SW}). The slaves lock to the negative (falling edge) of U1's output waveform.

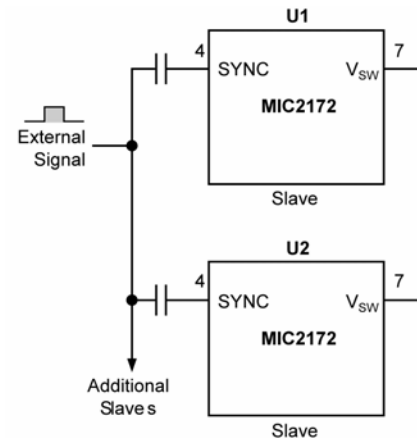

Figure 7. External Synchronization

Care must be exercised to insure that the master MIC2172 is always operating in continuous mode.

Figure 7 shows how one or more MIC2172s can be

locked to an external reference frequency. The slaves lock to the negative (falling edge) of the external reference waveform.

Soft Start

A diode-coupled capacitor from COMP to circuit ground slows the output voltage rise at turn on (figure 8).

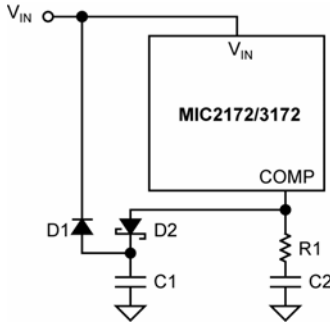

Figure 8. Soft Start

The additional time it takes for the error amplifier to charge the capacitor corresponds to the time it takes the output to reach regulation. Diode D1 discharges C1 when VIN is removed.

Another soft start circuit is shown in figure 8A. The circuit uses capacitor C1 to control the output risetime by providing feedback from the output to the FB pin. The output voltage starts to rise when the MIC3172 regulator starts switching. This is the dv/dt of the output will force a current through capacitor C1, which flows through the lower feedback resistor, R2, increasing the voltage on the FB pin. This increased voltage on the FB pin reduces the duty cycle at the V_{SW} pin, limiting the turn-on time of the output. Increasing the value of C1 causes the output voltage to rise more slowly. Diode D1 is reverse biased in normal operation and prevents C1 from appearing in parallel with the upper voltage divider resistor, which would affect stability and transient response. Zener diode D2 clamps the voltage seen by the feedback pin and provides a discharge path for C1 when the power supply is turned off.

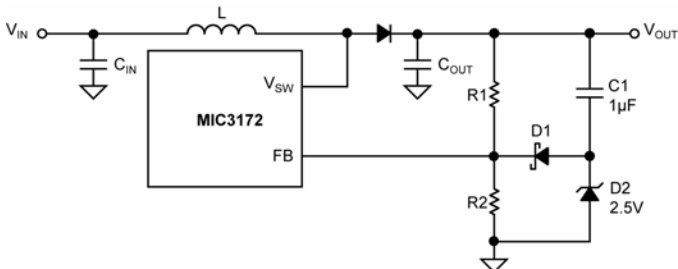

Figure 8a. Additional Soft Start Circuit

This circuit only limits the dv/dt of the output when the boost converter is running. It will not decrease the dv/dt or the initial inrush caused by applying the input voltage. Figure 8B shows the turn-on without a soft start circuit and Figure 8C shows how the soft start circuit reduces inrush and prevents output voltage overshoot.

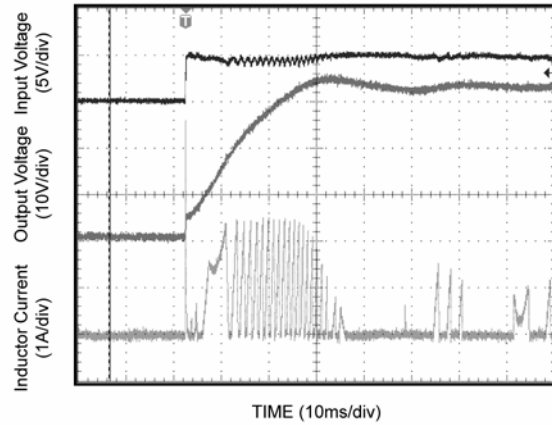

Figure 8b. Without Soft Start

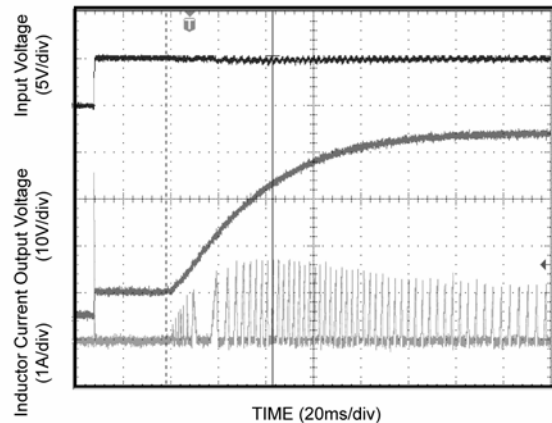

Figure 8c. With Soft Start

Current Limit

For designs demanding less output current than the MIC2172/3172 is capable of delivering, P GND 1 can be left open reducing the current capability of Q1 by one-half.

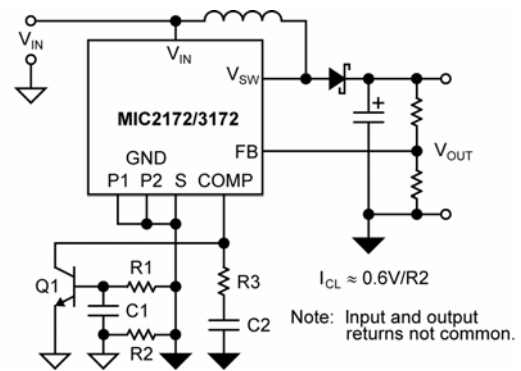

Figure 9. Current Limit

Alternatively, the maximum current limit of the MIC2172/3172 can be reduced by adding a voltage

clamp to the COMP output (figure 9). This feature can be useful in applications requiring either a complete shutdown of Q1's switching action or a form of current fold-back limiting. This use of the COMP output does not disable the oscillator, amplifiers or other circuitry, therefore the supply current is never less than approximately 5mA.

Thermal Management

Although the MIC2172/3172 family contains thermal protection circuitry, for best reliability, avoid prolonged operation with junction temperatures near the rated maximum.

The junction temperature is determined by first calculating the power dissipation of the device. For the MIC2172/3172, the total power dissipation is the sum of the device operating losses and power switch losses.

The device operating losses are the dc losses associated with biasing all of the internal functions plus the losses of the power switch driver circuitry. The dc losses are calculated from the supply voltage (V_{IN}) and device supply current (I_Q). The MIC2172/3172 supply current is almost constant regardless of the supply voltage (see "Electrical Characteristics"). The driver section losses (not including the switch) are a function of supply voltage, power switch current, and duty cycle.

$$P_{(bias+driver)} = (V_{IN} I_Q) + V_{IN} \left[I_{SW} \left(\frac{0.004 + \delta}{50} \right) \right]$$

where:

- P_(bias+driver) = device operating losses
- V_{IN} = supply voltage
- I_Q = quiescent supply current
- I_{SW} = power switch current
- (see "Design Hints: Switch Current Calculations")
- δ = duty cycle

$$\delta = \frac{V_{OUT} + V_F \pm V_{IN}}{V_{OUT} + V_F}$$

V_{OUT} = output voltage

V_F = D1 forward voltage drop

As a practical example refer to figure 1.

- V_{IN} = 5.0V
- I_Q = 0.006A
- I_{SW} = 0.625A
- δ = 60% (0.6)

Then:

$$P_{(bias+driver)} = (5 \times 0.006) + 5 \left[0.625 \left(\frac{0.004 + 0.6}{50} \right) \right]$$

$$P_{(bias+driver)} = 0.068W$$

Power switch dissipation calculations are greatly simplified by making two assumptions which are usually fairly accurate. First, the majority of losses in the power switch are due to on-losses. To find these losses, assign a resistance value to the collector/emitter terminals of the device using the saturation voltage versus collector current curves (see Typical Performance Characteristics). Power switch losses are calculated by modeling the switch as a resistor with the switch duty cycle modifying the average power dissipation.

$$P_{SW} = (I_{SW})^2 R_{SW} \delta$$

From the Typical performance Characteristics:

$$R_{SW} = 1\Omega$$

Then:

$$P_{SW} = (0.625)^2 \times 1 \times 0.6$$

$$P_{SW} = 0.234W$$

$$P_{(total)} = 0.068 + 0.234$$

$$P_{(total)} = 0.302W$$

The junction temperature for any semiconductor is calculated using the following:

$$T_J = T_A + P_{(total)} \theta_{JA}$$

Where:

- T_J = junction temperature
- T_A = ambient temperature (maximum)
- P_(total) = total power dissipation
- θ_{JA} = junction to ambient thermal resistance

For the practical example:

$$T_A = 70^\circ C$$

$$\theta_{JA} = 130^\circ C/W \text{ (for plastic DIP)}$$

Then:

$$T_J = 70 + 0.30 \cdot 130$$

$$T_J = 109^\circ C$$

This junction temperature is below the rated maximum of 150°C.

Grounding

Refer to figure 10. Heavy lines indicate high current paths.

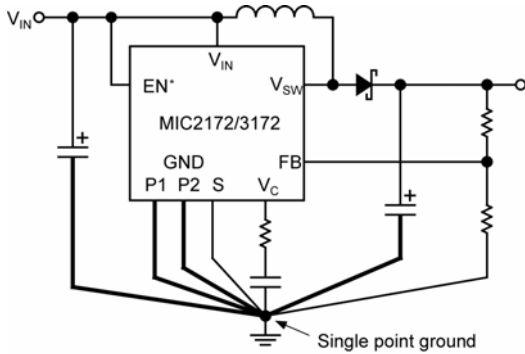

* MIC3172 only

Figure 10. Single Point Ground

A single point ground is strongly recommended for proper operation.

The signal ground, compensation network ground, and feedback network connections are sensitive to minor voltage variations. The input and output capacitor grounds and power ground conductors will exhibit voltage drop when carrying large currents. Keep the sensitive circuit ground traces separate from the power ground traces. Small voltage variations applied to the sensitive circuits can prevent the MIC2172/3172 or any switching regulator from functioning properly.

Applications and Design Hints

Access to both the collector and emitter(s) of the NPN power switch makes the MIC2172/3172 extremely versatile and suitable for use in most PWM power supply topologies.

Boost Conversion

Refer to figure 11 for a typical boost conversion application where a +5V logic supply is available but +12V at 0.14A is required.

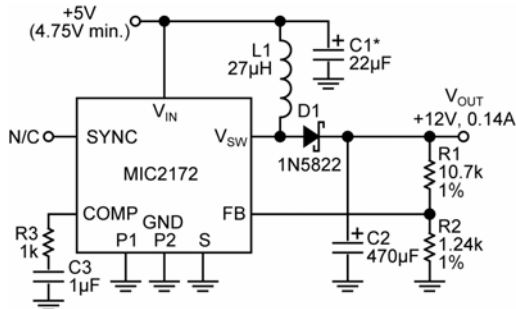

* Locate near MIC2172 when supply leads > 2"

Figure 11. 5V to 12V Boost Converter

The first step in designing a boost converter is determining whether inductor L1 will cause the converter to operate in either continuous or discontinuous mode. Discontinuous mode is preferred because the feedback control of the converter is simpler.

When L1 discharges its current completely during the MIC2172/3172's off-time, it is operating in discontinuous mode.

L1 is operating in continuous mode if it does not discharge completely before the MIC2172/3172 power switch is turned on again.

Discontinuous Mode Design

Given the maximum output current, solve equation (1) to determine whether the device can operate in discontinuous mode without initiating the internal device current limit.

$$I_{OUT} \leq \frac{\left(\frac{I_{CL}}{2}\right) V_{IN} \delta}{V_{OUT}} \quad (1)$$

$$\delta = \frac{V_{OUT} + V_F \pm V_{IN}}{V_{OUT} + V_F} \quad (1a)$$

Where:

I_{CL} = internal switch current limit

$I_{CL} = 1.25A$ when $\delta < 50\%$

$I_{CL} = 0.833 (2 - \delta)$ when $\delta \geq 50\%$

(Refer to Electrical Characteristics.)

I_{OUT} = maximum output current

V_{IN} = minimum input voltage

δ = duty cycle

V_{OUT} = required output voltage

V_F = D1 forward voltage drop

For the example in figure 11.

$I_{OUT} = 0.14A$

$I_{CL} = 1.147A$

$V_{IN} = 4.75V$ (minimum)

$\delta = 0.623$

$V_{OUT} = 12.0V$

$V_F = 0.6V$

Then:

$$I_{OUT} \leq \frac{\left(\frac{1.147}{2}\right) \times 4.75 \times 0.623}{12}$$

$$I_{OUT} \leq 0.141A$$

This value is greater than the 0.14A output current requirement so we can proceed to find the inductance value of L1.

$$L1 \leq \frac{(V_{IN} \delta)^2}{2 P_{OUT} f_{SW}} \quad (2)$$

Where:

$P_{OUT} = 12 \cdot 0.14 = 1.68W$

$f_{SW} = 1 \cdot 10^5 \text{kHz} (100\text{kHz})$

For our practical example:

$$L1 \leq \frac{(4.75 \times 0.623)^2}{2 \times 1.68 \times 1 \times 10^5}$$

$$I_{L1} \leq 26.062 \mu\text{H (use } 27 \mu\text{H)}$$

Equation (3) solves for L1's maximum current value.

$$I_{L1(\text{peak})} = \frac{V_{IN} T_{ON}}{L1} \quad (3)$$

Where:

$$T_{ON} = \delta / f_{SW} = 6.23 \times 10^{-6} \text{ sec}$$

$$I_{L1(\text{peak})} = \frac{4.75 \times 6.23 \times 10^{-6}}{27 \times 10^{-6}}$$

$$I_{L1(\text{peak})} = 1.096\text{A}$$

Use a 27μH inductor with a peak current rating of at least 1.4A.

Flyback Conversion

Flyback converter topology may be used in low power applications where voltage isolation is required or whenever the input voltage can be less than or greater than the output voltage. As with the step-up converter the inductor (transformer primary) current can be continuous or discontinuous. Discontinuous operation is recommended.

Figure 12 shows a practical flyback converter design using the MIC3172.

Switch Operation

During Q1's on time (Q1 is the internal NPN transistor—see block diagrams), energy is stored in T1's primary inductance. During Q1's off time, stored energy is partially discharged into C4 (output filter capacitor). Careful selection of a low ESR capacitor for C4 may provide satisfactory output ripple voltage making additional filter stages unnecessary.

C1 (input capacitor) may be reduced or eliminated if the MIC3172 is located near a low impedance voltage source.

Output Diode

The output diode allows T1 to store energy in its primary inductance (D2 nonconducting) and release energy into C4 (D2 conducting). The low forward voltage drop of a Schottky diode minimizes power loss in D2.

Frequency Compensation

A simple frequency compensation network consisting of R3 and C2 prevents output oscillations.

High impedance output stages (transconductance type) in the MIC2172/3172 often permit simplified loop-stability solutions to be connected to circuit ground, although a more conventional technique of connecting the components from the error amplifier output to its

inverting input is also possible.

Voltage Clipper

Care must be taken to minimize T1's leakage inductance, otherwise it may be necessary to incorporate the voltage clipper consisting of D1, R4, and C3 to avoid second breakdown (failure) of the MIC3172's power NPN Q1.

Enable/Shutdown

The MIC3172 includes the enable/shutdown feature. When the device is shutdown, total supply current is less than 1μA. This is ideal for battery applications where portions of a system are powered only when needed. If this feature is not required, simply connect EN to VIN or to a TTL high voltage.

Discontinuous Mode Design

When designing a discontinuous flyback converter, first determine whether the device can safely handle the peak primary current demand placed on it by the output power. Equation (8) finds the maximum duty cycle required for a given input voltage and output power. If the duty cycle is greater than 0.8, discontinuous operation cannot be used.

$$\delta \geq \frac{2 P_{OUT}}{I_{CL} V_{IN(\text{min})}} \quad (8)$$

For a practical example let:

$$P_{OUT} = 5.0\text{V} \times 0.25\text{A} = 1.25\text{W}$$

$$V_{IN} = 4.0\text{V to } 6.0\text{V}$$

$$I_{CL} = 1.25\text{A when } \delta < 50\%$$

Then:

$$\delta \geq \frac{2 \times 1.25}{1.25 \times 4}$$

$$\delta \geq 0.5 (50\%) \text{ Use } 0.55.$$

The slightly higher duty cycle value is used to overcome circuit inefficiencies. A few iterations of equation (8) may be required if the duty cycle is found to be greater than 50%.

Calculate the maximum transformer turns ratio **a**, or N_{PRI}/N_{SEC} , that will guarantee safe operation of the MIC2172/3172 power switch.

$$a \leq \frac{V_{CE} F_{CE} \pm V_{IN(\text{max})}}{V_{SEC}} \quad (9)$$

Where:

a = transformer maximum turns ratio

V_{CE} = power switch collector to emitter maximum voltage

F_{CE} = safety derating factor (0.8 for most commercial and industrial applications)

$V_{IN(max)}$ = maximum input voltage

V_{SEC} = transformer secondary voltage ($V_{OUT} + V_F$)

For the practical example:

V_{CE} = 65V max. for the MIC2172/3172

$F_{CE} = 0.8$

$V_{SEC} = 5.6V$

Then:

$$a \leq \frac{65 \times 0.8 \pm 6.0}{5.6}$$

$$a \leq 8.2143$$

Next, calculate the maximum primary inductance required to store the needed output energy with a power switch duty cycle of 55%.

$$L_{PRI} \leq \frac{0.5 f_{SW} V_{IN(min)}^2 T_{ON}^2}{P_{OUT}} \tag{10}$$

Where:

L_{PRI} = maximum primary inductance

f_{SW} = device switching frequency (100kHz)

$V_{IN(min)}$ = minimum input voltage

T_{ON} = power switch on time

Then:

$$L_{PRI} \leq \frac{0.5 \times 1 \times 10^5 \times 4.0^2 (5.5 \times 10^{-6})^2}{1.25}$$

$$L_{PRI} \leq 19.23\mu H$$

Use an 18μH primary inductance to overcome circuit inefficiencies.

To complete the design the inductance value of the secondary is found which will guarantee that the energy stored in the transformer during the power switch on time will be completely discharged into the output during the off-time. This is necessary when operating in discontinuous-mode.

$$L_{SEC} \leq \frac{0.5 f_{SW} V_{SEC}^2 T_{OFF}^2}{P_{OUT}} \tag{11}$$

Where:

L_{SEC} = maximum secondary inductance

T_{OFF} = power switch off time

Then:

$$L_{SEC} \leq \frac{0.5 \times 1 \times 10^5 \times 5.6^2 \times (4.5 \times 10^{-6})^2}{1.25}$$

$$L_{SEC} \leq 25.4\mu H$$

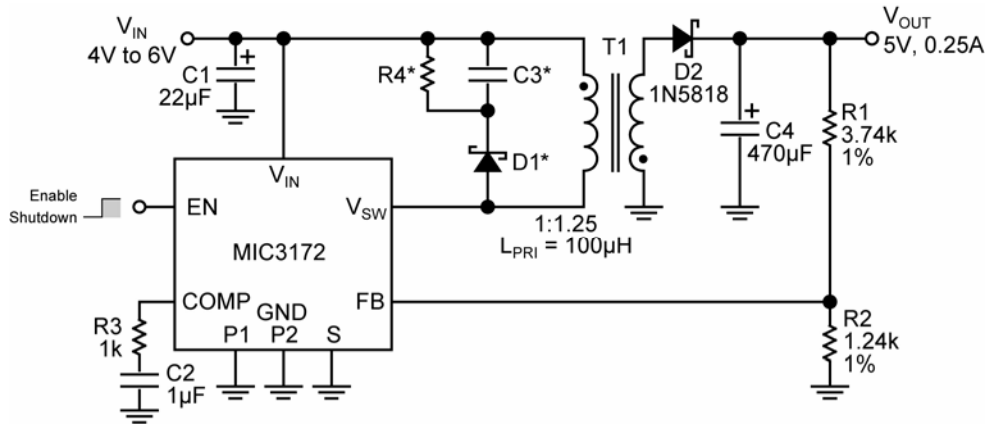

* Optional voltage clipper (may be req'd if T1 leakage inductance too high)

Figure 12. MIC3172 5V 0.25A Flyback Converter

Finally, recalculate the transformer turns ratio to insure that it is less than the value earlier found in equation (9).

$$a \leq \sqrt{\frac{L_{PRI}}{L_{SEC}}} \quad (12)$$

Then:

$$a \leq \sqrt{\frac{1.8 \times 10^{-5}}{2.54 \times 10^{-5}}}$$

$a \leq 0.84$ Use 0.8 (same as 1:1.25).

This ratio is less than the ratio calculated in equation (9). When specifying the transformer it is necessary to know the primary peak current which must be withstood without saturating the transformer core.

$$I_{PEAK(pri)} = \frac{V_{IN(min)} T_{ON}}{L_{PRI}}$$

So:

$$I_{PEAK(pri)} = \frac{4.0 \times 5.5 \times 10^{-6}}{18 \mu 8} \quad (13)$$

$$I_{PEAK(pri)} = 1.22A$$

Now find the minimum reverse voltage requirement for the output rectifier. This rectifier must have an average current rating greater than the maximum output current of 0.25A.

$$V_{BR} \geq \frac{V_{IN(max)} + (V_{OUT}a)}{F_{BR}a} \quad (14)$$

Where:

V_{BR} = output rectifier maximum peak reverse voltage rating

a = transformer turns ratio (0.8)

F_{BR} = reverse voltage safety derating factor (0.8)

Then:

$$V_{BR} \geq \frac{6.0 + (5.0 \times 0.8)}{0.8 \times 0.8}$$

$$V_{BR} \geq 15.625V$$

A 1N5817 will safely handle voltage and current requirements in this example.

Forward Converters

Micrel's MIC2172/3172 can be used in several circuit configurations to generate an output voltage which is less than the input voltage (buck or step-down topology). Figure 13 shows the MIC3172 in a voltage step-down application. Because of the internal architecture of these devices, more external components are required to implement a step-down regulator than with other devices offered by Micrel (refer to the LM257x or LM457x family of buck switchers). However, for step-down conversion

requiring a transformer (forward), the MIC2172/3172 is a good choice.

A 12V to 5V step-down converter using transformer isolation (forward) is shown in figure 14. Unlike the isolated flyback converter which stores energy in the primary inductance during the controller's on-time and releases it to the load during the off-time, the forward converter transfers energy to the output during the on-time, using the off-time to reset the transformer core. In the application shown, the transformer core is reset by the tertiary winding discharging T1's peak magnetizing current through D2.

For most forward converters the duty cycle is limited to 50%, allowing the transformer flux to reset with only two times the input voltage appearing across the power switch. Although during normal operation this circuit's duty cycle is well below 50%, the MIC2172 (and MIC3172) has a maximum duty cycle capability of 90%. If 90% was required during operation (start-up and high load currents), a complete reset of the transformer during the off-time would require the voltage across the power switch to be ten times the input voltage. This would limit the input voltage to 6V or less for forward converter applications.

To prevent core saturation, the application given here uses a duty cycle limiter consisting of Q1, C4 and R3. Whenever the MIC3172 exceeds a duty cycle of 50%, T1's reset winding current turns Q1 on. This action reduces the duty cycle of the MIC3172 until T1 is able to reset during each cycle.

Fluorescent Lamp Supply

An extremely useful application of the MIC3172 is generating an ac voltage for fluorescent lamps used as liquid crystal display back lighting in portable computers.

Figure 15 shows a complete power supply for lighting a fluorescent lamp. Transistors Q1 and Q2 together with capacitor C2 form a Royer oscillator. The Royer oscillator generates a sine wave whose frequency is determined by the series L/C circuit comprised of T1 and C2. Assuming that the MIC3172 and L1 are absent, and the transistors' emitters are grounded, circuit operation is described in "Oscillator Operation."

Oscillator Operation

Resistor R2 provides initial base current that turns transistor Q1 on and impresses the input voltage across one half of T1's primary winding (Pri 1). T1's feedback winding provides additional base drive (positive feedback) to Q1 forcing it well into saturation for a period determined by the Pri 1/C2 time constant. Once the voltage across C2 has reached its maximum circuit value, Q1's collector current will no longer increase. Since T1 is in series with Q1, this drop in primary current causes the flux in T1 to change and because of the

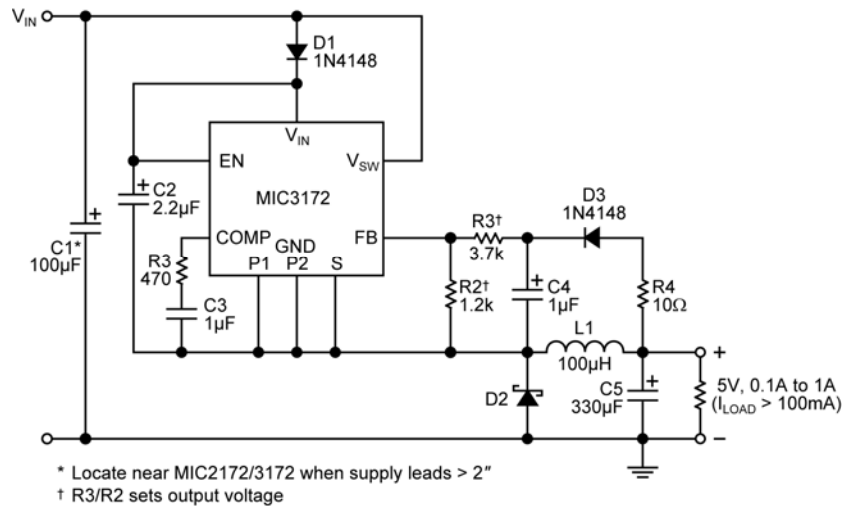

Figure 13. Step-Down or Buck Regulator

mutual coupling to the feedback winding further reduces primary current eventually turning Q1 off. The primary windings now change state with the feedback winding forcing Q2 on repeating the alternate half cycle exactly as with Q1. This action produces a sinusoidal voltage wave form; whose amplitude is proportional to the input voltage, across T1's primary winding which is stepped up and capacitively coupled to the lamp.

Lamp Current Regulation

Initial ionization (lighting) of the fluorescent lamp requires several times the ac voltage across it than is required to sustain current through the device. The current through the lamp is sampled and regulated by the MIC3172 to achieve a given intensity. The MIC3172 uses L1 to maintain a constant average current through the transistor emitters. This current controls the voltage amplitude of the Royer oscillator and maintains the lamp current. During the negative half cycle, lamp current is rectified by D3. During the positive half cycle, lamp current is rectified by D2 through R4 and R5. R3 and C5 filter the voltage dropped across R4 and R5 to the MIC3172's feedback pin. The MIC3172 maintains a

constant lamp current by adjusting its duty cycle to keep the feedback voltage at 1.24V. The intensity of the lamp is adjusted using potentiometer R5. The MIC3172 adjusts its duty cycle accordingly to bring the average voltage across R4 and R5 back to 1.24V.

On/Off Control

Especially important for battery powered applications, the lamp can be remotely or automatically turned off using the MIC3172's EN pin. The entire circuit draws less than 1µA while shutdown.

Efficiency

To obtain maximum circuit efficiency careful selection of Q1 and Q2 for low collector to emitter saturation voltage is a must. Inductor L1 should be chosen for minimal core and copper losses at the switching frequency of the MIC3172, and T1 should be carefully constructed from magnetic materials optimized for the output power required at the Royer oscillator frequency. Suitable inductors may be obtained from Coiltronics, Inc., tel: (407) 241-7876.

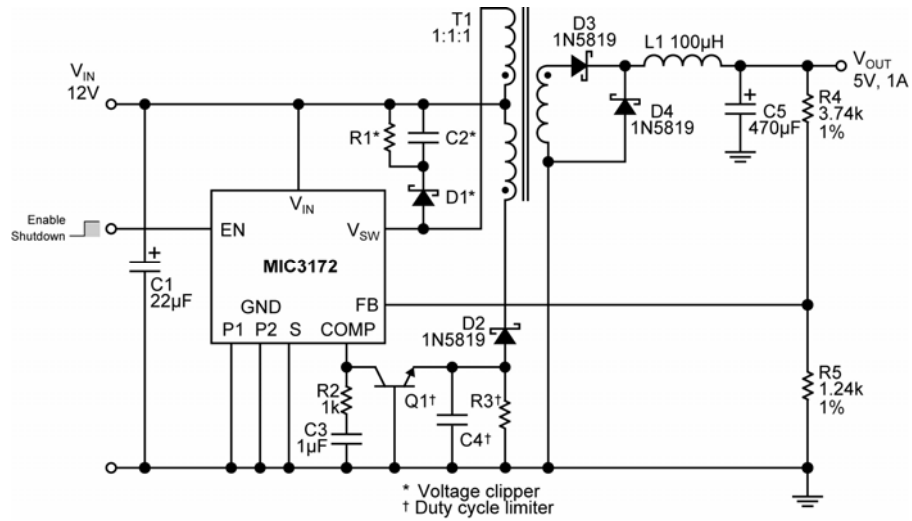

Figure 14. 12V to 5V Forward Converter

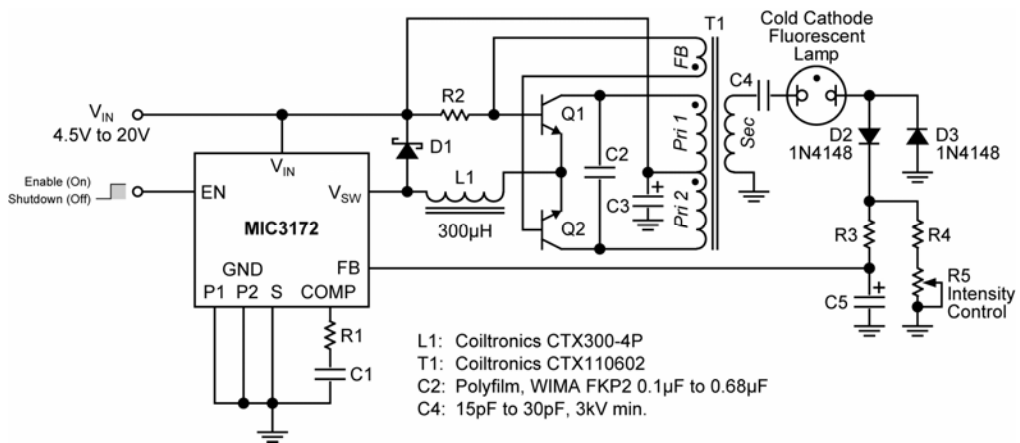
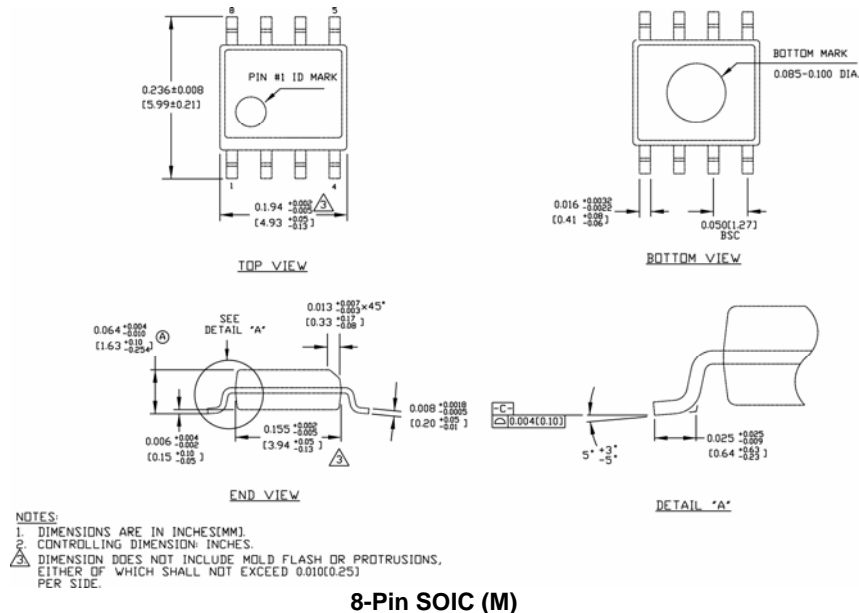
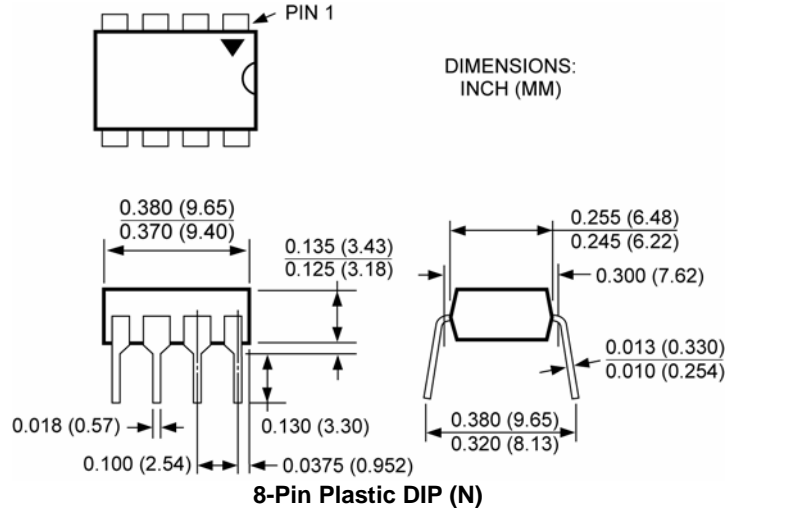

Figure 15. LCD Backlight Fluorescent Lamp Supply

Package Information



MICREL, INC. 2180 FORTUNE DRIVE SAN JOSE, CA 95131 USA
 TEL +1 (408) 944-0800 FAX +1 (408) 474-1000 WEB <http://www.micrel.com>

The information furnished by Micrel in this data sheet is believed to be accurate and reliable. However, no responsibility is assumed by Micrel for its use. Micrel reserves the right to change circuitry and specifications at any time without notification to the customer.

Micrel Products are not designed or authorized for use as components in life support appliances, devices or systems where malfunction of a product can reasonably be expected to result in personal injury. Life support devices or systems are devices or systems that (a) are intended for surgical implant into the body or (b) support or sustain life, and whose failure to perform can be reasonably expected to result in a significant injury to the user. A Purchaser's use or sale of Micrel Products for use in life support appliances, devices or systems is a Purchaser's own risk and Purchaser agrees to fully indemnify Micrel for any damages resulting from such use or sale.

© 2004 Micrel, Incorporated.