



MIC1815

Microprocessor Reset Circuit

General Description

The MIC1815 is an inexpensive microprocessor supervisory circuit that monitors power supplies in microprocessor based systems.

The function of these devices is to assert a reset if the power supply drops below a designated reset threshold level. Several different reset threshold levels are available to accommodate 10% or 20% drop in 3.3V powered systems.

The MIC1815 has an active low /RESET output. The reset output is guaranteed to remain asserted for a minimum of 100ms after V_{CC} has risen above the designated reset threshold level. The MIC1815 comes in a 3-pin SOT-23 package.

Features

- Precision voltage monitor for 10% or 20% drop in 3.3V power supplies
- /RESET remains valid with V_{CC} as low as 1V
- 5 μ A supply current
- 100ms minimum reset pulse width
- No external components required
- Available in 3-pin SOT-23 package

Applications

- Portable equipment
- Intelligent instruments
- Critical microprocessor power monitoring
- Printers/computers
- Embedded controllers

Ordering Information

Part Number	Marking	Threshold Voltage	Operating Temp. Range	Package	Pb-Free
MIC1815-10U	ND	2.88V	-40°C to +85°C	SOT-23	No
MIC1815-20U	NE	2.55V	-40°C to +85°C	SOT-23	No
MIC1815-10UY	<u>ND</u>	2.88V	-40°C to +85°C	SOT-23	Yes
MIC1815-20UY	<u>NE</u>	2.55V	-40°C to +85°C	SOT-23	Yes

Typical Application

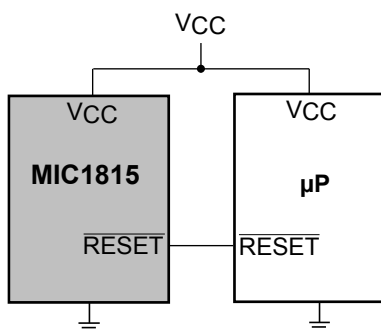

Pin Configuration

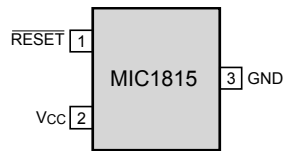

3-Lead SOT23

Pin Description

Pin Number	Pin Name	Pin Function
1	/RESET	/RESET goes low if V_{CC} falls below the reset threshold and remains asserted for one reset timeout period (100ms min) after V_{CC} exceeds the reset threshold.
2	VCC	Power supply input.
3	GND	IC ground pin

Absolute Maximum Ratings(Note 1)

Terminal Voltage (V_{CC}).....-0.3V to +6V
 Input Current (V_{CC})..... 20mA
 Output Current (/RESET) 20mA
 Rate of Rise (V_{CC})..... 100V/ μ s
 Lead Temperature (soldering, 10 sec.)..... 300°C
 Storage Temperature (T_S) -65°C to 150°C
 ESD Rating, **Note 3**..... 3kV

Operating Ratings(Note 2)

Operating Temperature Range
 MIC1815-10U -40°C to +85°C
 MIC1815-20U -40°C to +85°C
 Power Dissipation ($T_A = +70^\circ\text{C}$) 320mW

Electrical Characteristics

For typical values, $V_{CC} = 3.3\text{V}$, $T_A = 25^\circ\text{C}$; **bold** values indicate $-40^\circ\text{C} \leq T_A \leq +85^\circ\text{C}$; unless noted

Symbol	Parameter	Condition	Min	Typ	Max	Units
V_{CC}	Operating Temperature Range	$T_A = -40^\circ\text{C}$ to $+85^\circ\text{C}$	1		5.5	V
I_{CC}	Supply Current			5	20	μA
V_{TH}	Reset Voltage Threshold	MIC1815-10U	2.80	2.88	2.97	V
		MIC1815-20U	2.47	2.55	2.64	V
t_{RST}	Reset Timeout Period		100	150	250	ms
V_{OH}	/RESET Output Voltage	$I_{SOURCE} = 800\mu\text{A}$	1.5			V
V_{OL}	/RESET Output Voltage	$V_{CC} = V_{TH}$ min., $I_{SINK} = 10\text{mA}$			0.4	V
		$V_{CC} > 1\text{V}$, $I_{SINK} = 50\mu\text{A}$			0.3	V

- Note 1.** Exceeding the absolute maximum rating may damage the device.
- Note 2.** The device is not guaranteed to function outside its operating rating.
- Note 3.** Devices are ESD sensitive. Handling precautions recommended. Human body model, 1.5k in series with 100pF.

Timing Diagram

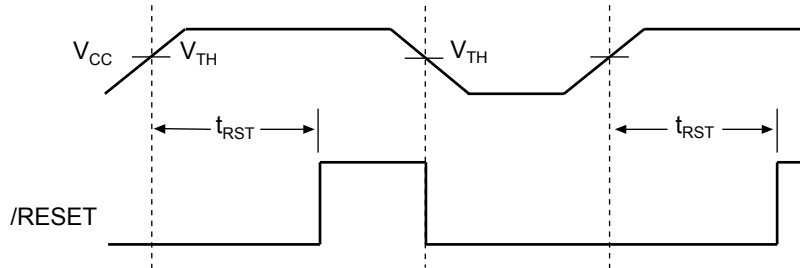

Reset Timing Diagram

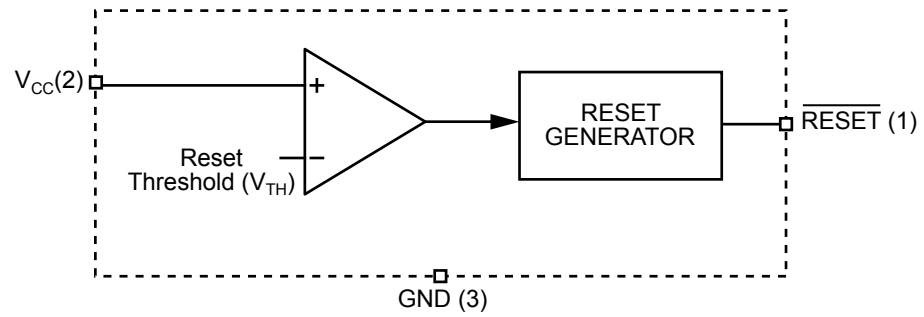
Functional Diagram

Applications Information

Microprocessor Reset

The /RESET pin is asserted whenever V_{CC} falls below the reset threshold voltage. The reset pin remains asserted for a period of t_{RST} after V_{CC} has risen above the reset threshold voltage. The reset function ensures the microprocessor is properly reset and powers up into a known condition after a power failure. /RESET will remain valid with V_{CC} as low as 1V.

V_{CC} Transients

The MIC1815 is relatively immune to negative-going V_{CC} glitches below the reset threshold. Typically, a negative-going transient 125mV below the reset threshold with a duration of 20 μ s or less will not cause an unwanted reset.

/RESET Valid at Low Voltage

A resistor can be added from the /RESET pin-to-ground to ensure the /RESET output remains low with V_{CC} down to 0V. A 100k Ω resistor connected from /RESET-to-ground is recommended. The resistor should be large enough not to load the /RESET output and small enough to pull-down any stray leakage currents. See Figure below.

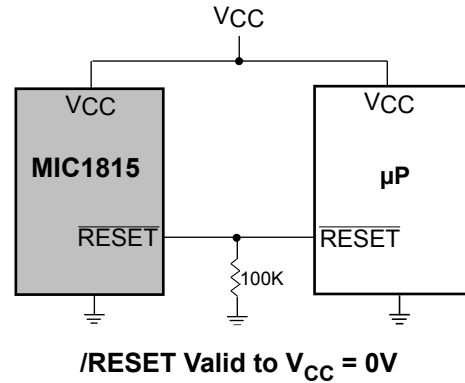

Package Information

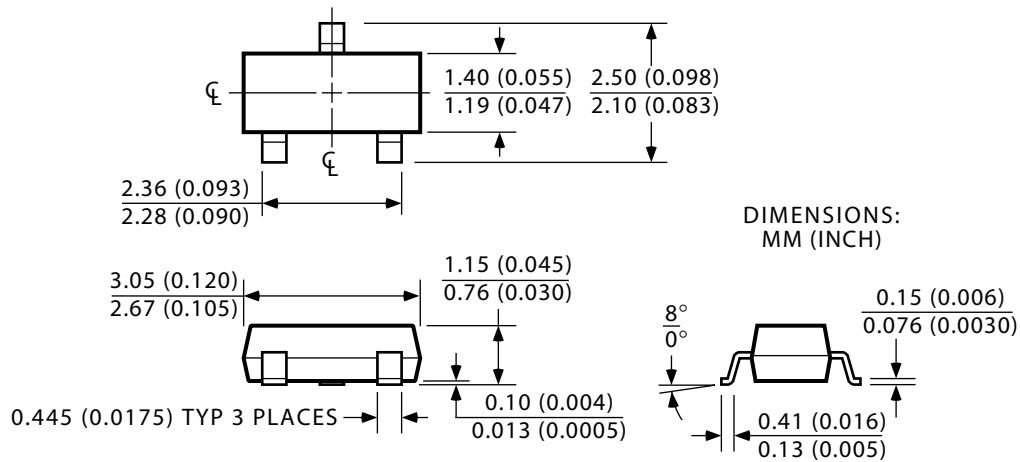

3-Pin SOT-23 Small Outline Transistor

MICREL, INC. 2180 FORTUNE DRIVE SAN JOSE, CA 95131 USA

TEL + 1 (408) 944-0800 FAX + 1 (408) 474-1000 WEB <http://www.micrel.com>

The information furnished by Micrel in this datasheet is believed to be accurate and reliable. However, no responsibility is assumed by Micrel for its use. Micrel reserves the right to change circuitry and specifications at any time without notification to the customer.

Micrel Products are not

reasonably be expected to result in personal injury. Life support devices or systems are devices or systems that (a) are intended for surgical implant into the body or (b) support or sustain life, and whose failure to perform can be reasonably expected to result in a significant injury to the user. A Purchaser's use or sale of Micrel Products for use in life support appliances, devices or systems is at Purchaser's own risk and Purchaser agrees to fully indemnify

Micrel for any damages resulting from such use or sale.

© 2005 Micrel, Incorporated.