



MIC1555/1557

IttyBitty® RC Timer/Oscillator

General Description

The MIC1555 IttyBitty® CMOS RC timer/oscillator and MIC1557 IttyBitty® CMOS RC oscillator are designed to provide rail-to-rail pulses for precise time delay or frequency generation.

The devices are similar in function to the industry standard “555”, without a frequency control (FC) pin or an open-collector discharge (D) pin. The threshold pin (THR) has precedence over the trigger (TRG) input, ensuring that the BiCMOS output is off when TRG is high.

The MIC1555 can be used as an astable (oscillator) or monostable (one-shot) with separate threshold and trigger inputs. In the one-shot mode, the output pulse width is precisely controlled by an external resistor and a capacitor. Time delays may be accurately controlled from microseconds to hours. In the oscillator mode, the output is used to provide precise feedback, with a minimum of one resistor and one capacitor producing a 50% duty cycle square wave.

The MIC1557 is designed for astable (oscillator) operation only, with a chip select/reset (CS) input for low power shutdown. One resistor and one capacitor provide a 50% duty cycle square wave. Other duty-cycle ratios may be produced using two diodes and two resistors.

The MIC1555/7 is powered from a +2.7V to +18V supply voltage and is rated for -40°C to +85°C ambient temperature range. The MIC1555/7 is available in SOT-23-5, and thin SOT23-5 5-pin packages. A low profile, ultra-thin, (UTDFN), version of the MIC1555 (with chip select) is also available.

Datasheets and support documentation are available on Micrel's website at: www.micrel.com.

Features

- +2.7V to +18V operation
- Low current
 - <1μA typical shutdown mode (MIC1557)
 - 200μA typical (TRG and THR low) at 3V supply
- Timing from microseconds to hours
- “Zero” leakage trigger and threshold inputs
- 50% square wave with one resistor, one capacitor
- Threshold input precedence over trigger input
- <15Ω output on resistance
- No output cross-conduction current spikes
- <0.005%/°C temperature stability
- <0.055%/V supply stability
- 10-pin ultra-thin DFN package (2mm x 2mm x 0.4mm)
- Small SOT-23-5 surface mount package

Applications

- Precision timer
- Pulse generation
- Sequential timing
- Time-delay generation
- Missing pulse detector
- Micropower oscillator to 5MHz
- Charge-pump driver
- LED blinker
- Voltage converter
- Linear sweep generator
- Variable frequency and duty cycle oscillator

IttyBitty is a registered trademark of Micrel, Inc.

Micrel Inc. • 2180 Fortune Drive • San Jose, CA 95131 • USA • tel +1 (408) 944-0800 • fax + 1 (408) 474-1000 • <http://www.micrel.com>

Typical Applications

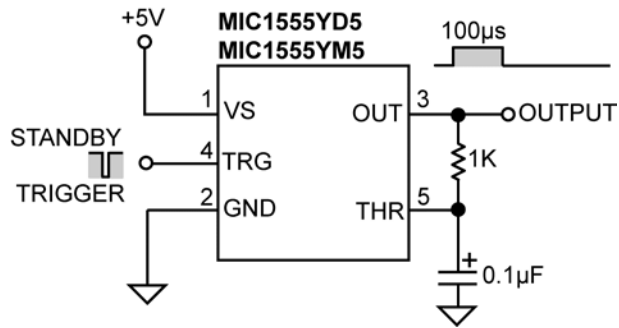

Monostable (One-Shot)

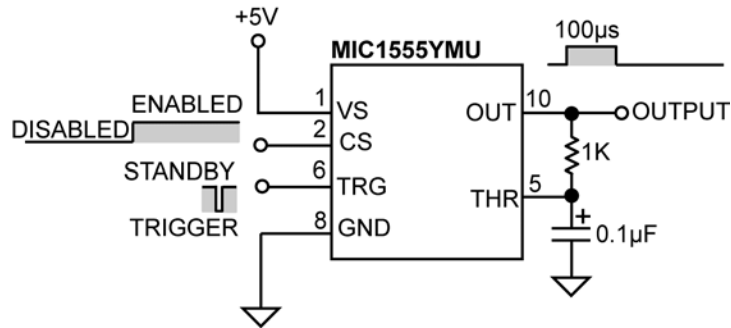

Monostable (with Enable)

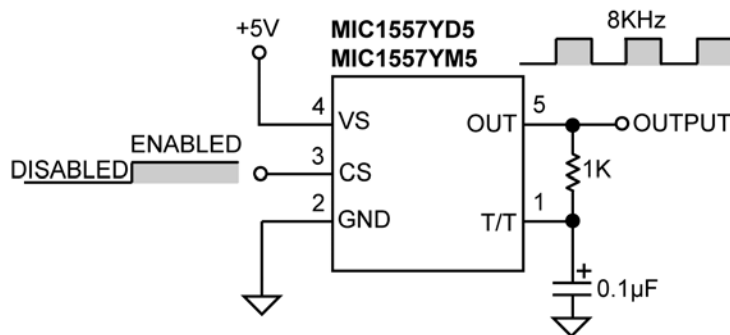

Astable (Oscillator)

Ordering Information

Part Number	Top Marking ^(1, 2)	Temperature Range	Package	Package Height (mm)
MIC1555YD5	<u>T</u> 12	-40°C to +85°C	5-Pin Thin SOT-23	1.0 (maximum)
MIC1555YMU	T14	-40°C to +85°C	10-Pin 2mm x 2mm UTDFN	0.4 (maximum)
MIC1555YM5	<u>T</u> 10	-40°C to +85°C	5-Pin SOT-23	0.9 – 1.45
MIC1557YD5	<u>T</u> 13	-40°C to +85°C	5-Pin Thin SOT-23	1.0 (maximum)
MIC1557YM5	<u>T</u> 11	-40°C to +85°C	5-Pin SOT-23	0.9 – 1.45

Note:

- Underbars () shown for the top marking may not be to scale.
- The top marking in the YMU package does not have an underbar.

Pin Configuration (MIC1555 SOT-23 and TSOT-23)

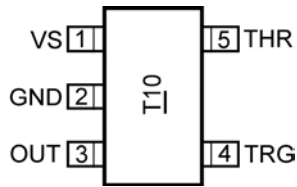

5-Pin SOT-23 (M5)
(Top View)

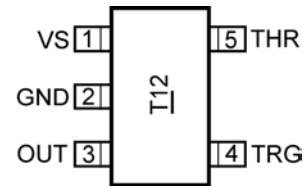

5-Pin TSOT-23 (D5)
(Top View)

Pin Description (MIC1555 SOT-23 and TSOT-23)

Pin Number	Pin Name	Pin Function
1	VS	Supply (Input): +2.7V to +18V supply.
2	GND	Ground: Supply return.
3	OUT	Output: CMOS totem-pole output.
4	TRG	Trigger (Input): Sets output high. Active low (at $\leq 2/3V_S$ nominal).
5	THR	Threshold (Dominant Input): Sets output low. Active high (at $\geq 2/3V_S$ nominal).

Pin Configuration (MIC1555 UTDFN)

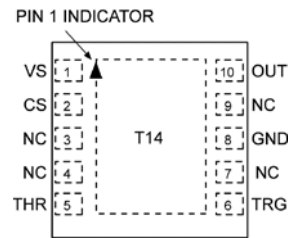

10-Pin UTDFN (MU)
(Top View)

Pin Description (MIC1555 UTDFN)

Pin Number	Pin Name	Pin Function
1	VS	Supply (Input): +2.7 to +18V supply.
2	CS	Chip Select/Reset (Input): Active high at $>2/3V_S$. Output off when low at $<1/3V_S$. If chip select functionality is not desired, CS may be connected directly to VS.
3, 4, 7, 9	NC	No Connect. This pin is not internally connected.
5	THR	Threshold (Dominant Input): Sets output low. Active high (at $\geq 2/3V_S$ nominal).
6	TRG	Trigger (Input): Sets output high. Active low (at $\leq 2/3V_S$ nominal).
8	GND	Ground: Supply return.
10	OUT	Output: CMOS totem-pole output.

Pin Configuration (MIC1557 SOT-23 and TSOT-23)

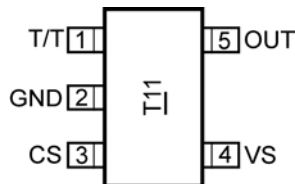

5-Pin SOT-23 (M5)
(Top View)

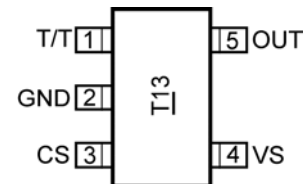

5-Pin TSOT-23 (D5)
(Top View)

Pin Description (MIC1557 SOT-23 and TSOT-23)

Pin Number	Pin Name	Pin Function
1	T/T	Trigger/Threshold (Input): Internally connected to both threshold and trigger functions. When the voltage at this pin is $\leq 2/3V_S$ it will set the output high. When the voltage at this pin is $\geq 2/3V_S$ it will set the output low.
2	GND	Ground: Supply return.
3	CS	Chip Select/Reset (Input): Active high at $>2/3V_S$. Output off when low at $<1/3V_S$. If chip select functionality is not desired, CS may be connected directly to VS.
4	VS	Supply (Input): +2.7 to +18V supply.
5	OUT	Output: CMOS totem-pole output.

Absolute Maximum Ratings⁽³⁾

Supply Voltage (V_S).....	+22V
Threshold Voltage (V_{THR} , $V_{T/T}$).....	+22V
Trigger Voltage (V_{TGR} , $V_{T/T}$).....	+22V
Lead Temperature (soldering, 10s).....	300°C
Ambient Storage Temperature.....	-65°C to +150°C
ESD HBM Rating ⁽⁵⁾	2kV
ESD MM Rating.....	200V

Operating Ratings⁽⁴⁾

Supply voltage (V_S).....	+2.7V to +18V
Ambient Temperature (T_A).....	-40°C to +85°C
Package Thermal Resistance	
SOT23-5 and Thin SOT23-5 (θ_{JA}).....	250°C/W
2mm x 2mm UTDFN (θ_{JA}).....	90°C/W

Electrical Characteristics

$T_A = 25^\circ\text{C}$, **bold** values indicate $-40^\circ\text{C} \leq T_A \leq +85^\circ\text{C}$, unless noted.

Parameter	Condition	Min.	Typ.	Max.	Units
Supply Current	$V_S = 5\text{V}$		240	300	μA
	$V_S = 15\text{V}$		350	400	
Monostable Timing Accuracy	$R_A = 10\text{k}\Omega$, $C = 0.1\mu\text{F}$, $V_S = 5\text{V}$		2		%
	$R_A = 10\text{k}\Omega$, $C = 0.1\mu\text{F}$, $V_S = 5\text{V}$	858		1161	μs
Monostable Drift Overtemperature	$V_S = 5\text{V}$, $-55^\circ\text{C} \leq T_A \leq +125^\circ\text{C}$ ⁽⁶⁾		100		ppm/°C
	$V_S = 10\text{V}$, $-55^\circ\text{C} \leq T_A \leq +125^\circ\text{C}$ ⁽⁶⁾		150		
	$V_S = 15\text{V}$, $-55^\circ\text{C} \leq T_A \leq +125^\circ\text{C}$ ⁽⁶⁾		200		
Monostable Drift over Supply	$V_S = 5\text{V}$ to 15V ⁽⁶⁾		0.5		%/V
Astable Timing Accuracy	$R_A = R_B = 10\text{k}\Omega$, $C = 0.1\mu\text{F}$, $V_S = 5\text{V}$		2		%
	$R_A = R_B = 10\text{k}\Omega$, $C = 0.1\mu\text{F}$, $V_S = 5\text{V}$	1717		2323	μs
Maximum Astable Frequency	$R_T = 1\text{k}\Omega$, $C_T = 47\text{pF}$, $V_S = 8\text{V}$		5		MHz
Astable Drift Overtemperature	$V_S = 5\text{V}$, $-55^\circ\text{C} \leq T_A \leq +125^\circ\text{C}$ ⁽⁶⁾		100		ppm/°C
	$V_S = 10\text{V}$, $-55^\circ\text{C} \leq T_A \leq +125^\circ\text{C}$ ⁽⁶⁾		150		
	$V_S = 15\text{V}$, $-55^\circ\text{C} \leq T_A \leq +125^\circ\text{C}$ ⁽⁶⁾		200		
Astable Drift over Supply	$V_S = 5\text{V}$ to 15V ⁽⁶⁾		0.5		%/V
Threshold Voltage	$V_S = 15\text{V}$	61	67	72	%/V _S
Trigger Voltage	$V_S = 15\text{V}$	27	32	37	%/V _S
Trigger Current	$V_S = 15\text{V}$			50	nA
Threshold Current	$V_S = 15\text{V}$			50	nA
Chip Select	on > 2/3 V _S	50	67	72	%/V _S
	off < 1/3 V _S	28	33	50	

Notes:

- Exceeding the absolute maximum ratings may damage the device
- The device is not guaranteed to function outside its operating ratings.
- Devices are ESD protected, however handling precautions recommended.
- Not tested.

Electrical Characteristics (Continued)

$T_A = 25^\circ\text{C}$, **bold** values indicate $-40^\circ\text{C} \leq T_A \leq +85^\circ\text{C}$, unless noted.

Parameter	Condition	Min.	Typ.	Max.	Units
Output Voltage Drop	$V_S = 15\text{V}$, $I_{\text{SINK}} = 20\text{mA}$		0.3	1.25	V
	$V_S = 5\text{V}$, $I_{\text{SINK}} = 3.2\text{mA}$		0.08	0.5	
	$V_S = 15\text{V}$, $I_{\text{SOURCE}} = 20\text{mA}$	14.1	14.7		
	$V_S = 5\text{V}$, $I_{\text{SOURCE}} = 3.2\text{mA}$	3.8	4.7		
Supply Voltage	Functional Operation ⁽⁶⁾	2.7		18	V
Output Rise Time	$R_L = 10\text{M}\Omega$, $C_L = 10\text{pF}$, $V_S = 5\text{V}^{(6)}$		15		ns
Output Fall Time	$R_L = 10\text{M}\Omega$, $C_L = 10\text{pF}$, $V_S = 5\text{V}^{(6)}$		15		ns

Typical Characteristics

$T_A = 25^\circ\text{C}$, $V_{IN} = +5\text{V}$.

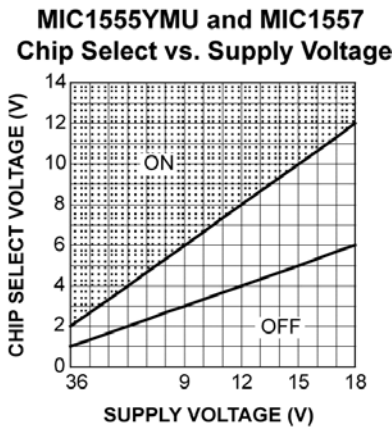
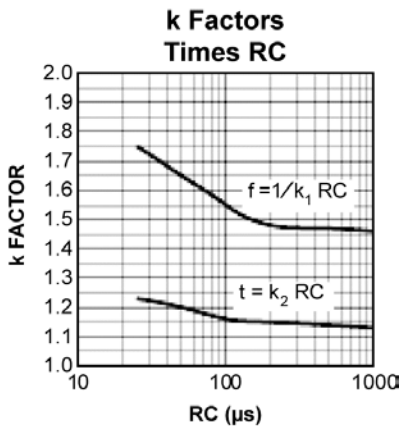
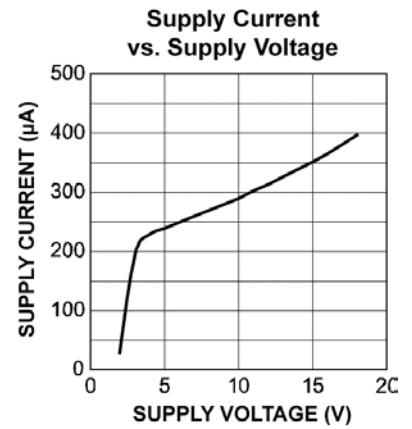
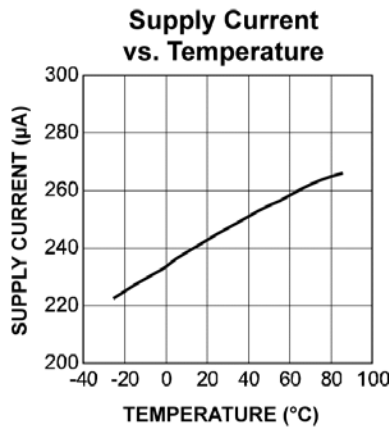
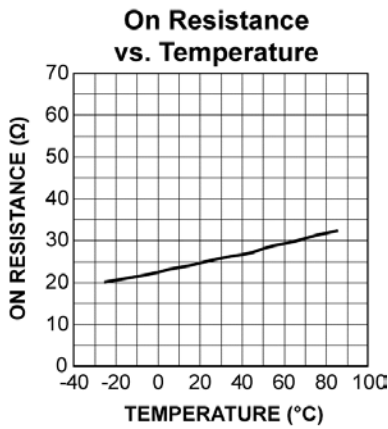
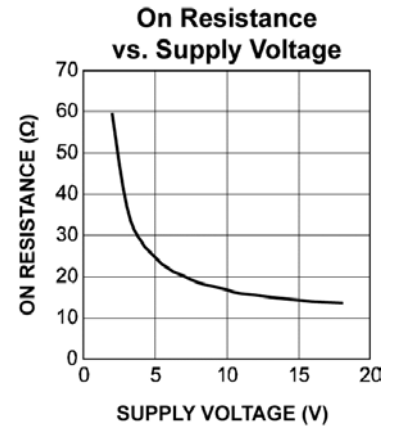
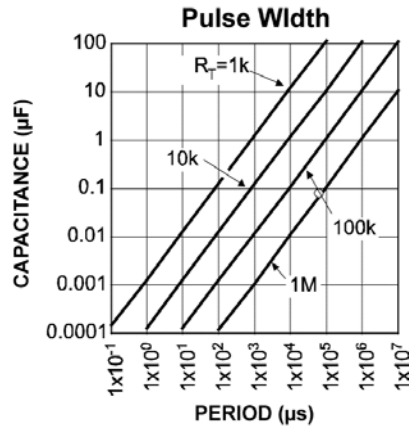
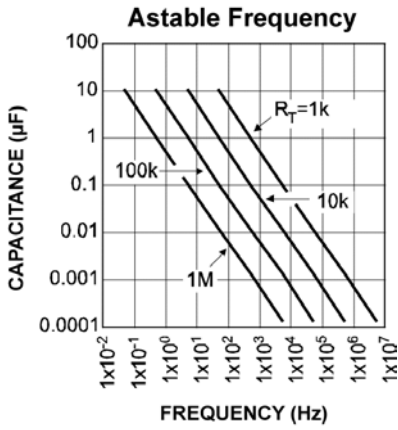

MIC1555 Functional Block Diagrams

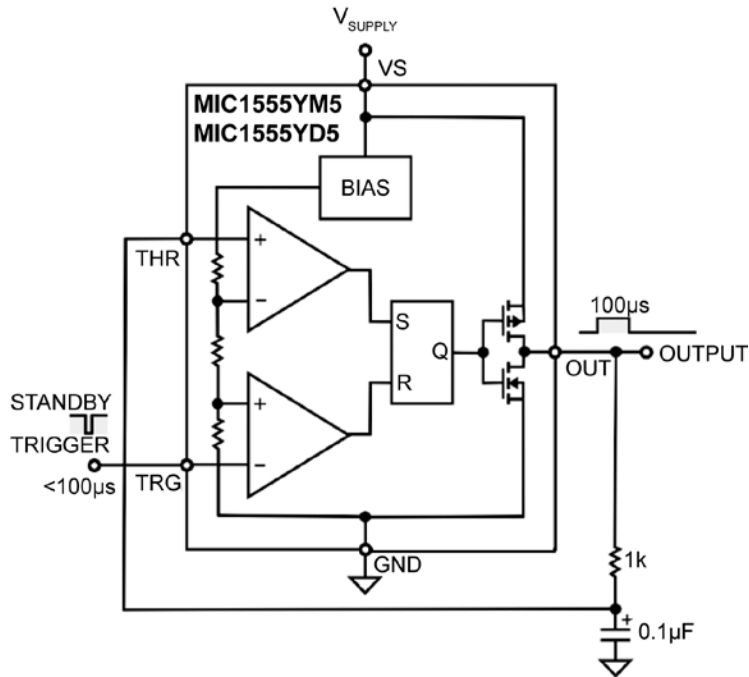

MIC155YM5/MIC155YD5 Block Diagram with External Components (Monostable Configuration)

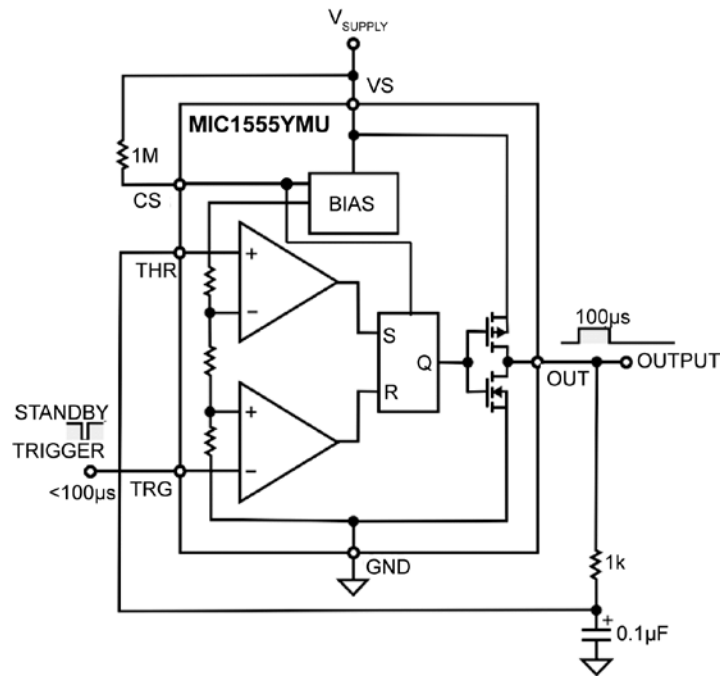

MIC1555YMU Block Diagram with External Components (Monostable Configuration)

MIC1557 Functional Block Diagram

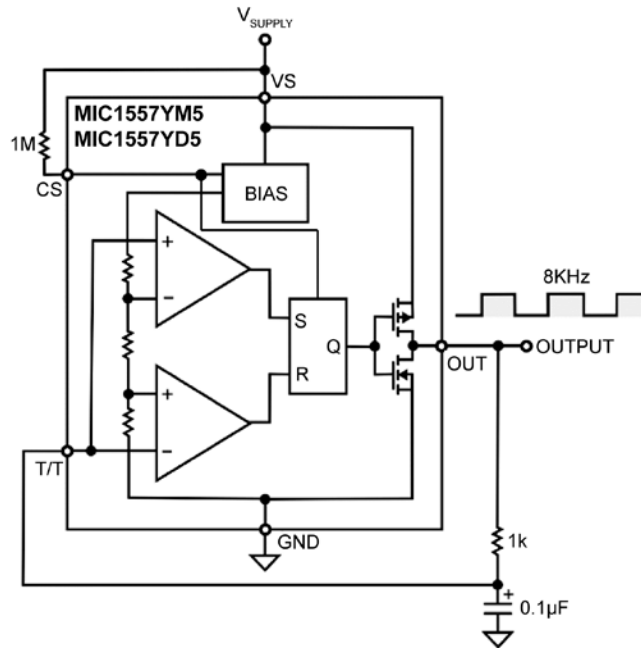

MIC1557YM5/MIC1557YD5 Block Diagram with External Components (Astable Configuration)

Functional Description

The MIC1555/7 provides the logic for creating simple RC timer or oscillator circuits.

The MIC1555 has separate THR (threshold) and TRG (trigger) connections for monostable (one-shot) or astable (oscillator) operation.

The MIC1557 has a single T/T (threshold and trigger) connection for astable (oscillator) operation only. The MIC1557 includes a CS (chip select/reset) control.

For more information, refer to the [MIC1555 Functional Block Diagrams](#) and [MIC1557 Functional Block Diagram](#).

Supply

Voltage supply (VS) is rated for +2.7V to +18V. An external capacitor is recommended to decouple noise.

Resistive Divider

The resistive voltage divider is constructed of three equal value resistors to produce $1/3V_S$ and $2/3V_S$ voltage for trigger and threshold reference voltages.

Chip Select/Reset (MIC1555YMU and MIC1557 only)

Chip select/reset (CS) controls the bias supply to the oscillator's internal circuitry. CS must be connected to CMOS logic-high or logic-low levels. Floating CS will result in unpredictable operation. When the chip is deselected, the supply current is less than $1\mu A$. Forcing CS low resets the device by setting the flip flop, forcing the output low. If Chip Select functionality is not desired, CS may be connected directly to VS.

Threshold Comparator

The threshold comparator is connected to S (set) on the RS flip-flop. When the threshold voltage ($2/3V_S$) is reached, the flip-flop is set, making the output low. THR is dominant over TRG.

Trigger Comparator

The trigger comparator is connected to R (reset) on the RS flip-flop. When TRG (trigger) goes below the trigger voltage ($1/3V_S$), the flip-flop resets, making the output high.

Flip-Flop and Output

A reset signal causes Q to go low, turning on the P-channel MOSFET and turning off the N-channel MOSFET. This makes the output rise to nearly VS.

A set signal causes Q to go high, turning off the P-channel MOSFET, and turning on the N-channel MOSFET, grounding OUT.

Basic Monostable Operation

A momentary low signal applied to TRG causes the output to go high. The external capacitor charges slowly through the external resistor. When threshold voltage (V_{THR}) reaches $2/3V_S$, the output is switched off, discharging the capacitor. During power-on, a single pulse may be generated.

For more information, refer to the [MIC1555 Functional Block Diagrams](#).

Basic Astable Operation

Refer to the MIC1557 functional diagram.

The MIC1557 starts with T/T low, causing the output to go high. The external capacitor charges slowly through the external resistor. When $V_{T/T}$ reaches $2/3V_S$ (threshold voltage), the output is switched off, slowly discharging the capacitor. When $V_{T/T}$ decreases to $1/3V_S$ (trigger voltage), the output is switched on, causing $V_{T/T}$ to rise again, repeating the cycle.

For more information, refer to the [MIC1557 Functional Block Diagram](#).

Application Information

Basic Monostable (One-Shot) Circuit

A monostable oscillator produces a single pulse each time that it is triggered, and is often referred to as a “one-shot”. The pulse width is constant, while the time between pulses depends on the trigger input. One-shots are generally used to “stretch” incoming pulses, of varying widths, to a fixed width. The IttyBitty MIC1555 is designed for monostable operation, but may also be connected to provide astable oscillations. The pulse width is determined by the time it takes to charge a capacitor from ground to a comparator trip point. If the capacitor (C_T) is charged through a resistor (R_T) connected to the output of an MIC1555, the trip point is approximately $1.1R_T C_T$ (the same time as the initial power-on cycle of an astable circuit.) If the trigger pulse of an MIC1555 remains low longer than the output pulse width, short oscillations may be seen in the output of a one-shot circuit, since the threshold pin has precedence over the trigger pin. These occur since the output goes low when the threshold is exceeded, and then goes high again as the trigger function is asserted. AC coupling the input with a series capacitor and a pull-up resistor, with an RC time constant less than the pulse width, will prevent these short oscillations. A diode (D_T) in parallel with (R_T) resets the one-shot quickly.

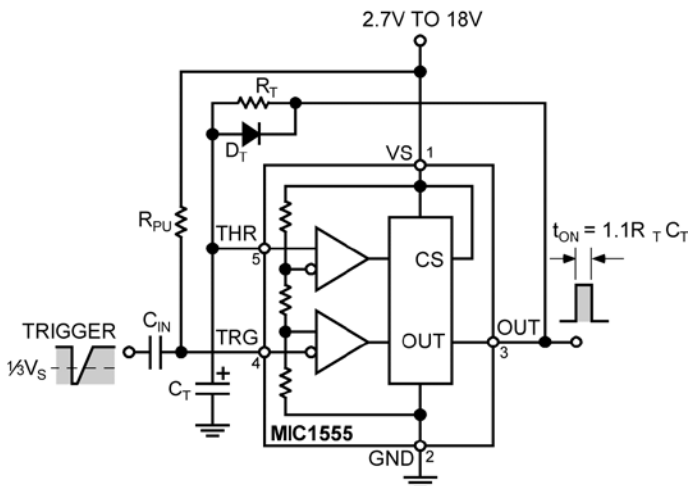

Figure 1. One-Shot Diagram

The period of a monostable circuit is:

$$t = k_2 RC$$

where:

t = period (s)

k_2 = Constant (see [Typical Characteristics](#))

R = Resistance (Ω)

C = Capacitance (F)

Basic Astable (Oscillator) Circuits

An astable oscillator switches between two states, “on” and “off”, producing a continuous square wave. The IttyBitty MIC1557 is optimized for this function, with the two comparator inputs, threshold and trigger (T/T), tied together internally. CS is brought out to allow on-off control of the oscillator.

The MIC1555 may also be used as an astable oscillator by tying the threshold and trigger pins together, forming a T/T pin. If a resistor (R_T) is connected from the output to a grounded timing capacitor (C_T), the voltage at their junction will ramp up from ground when the output goes high. If the T/T pin is connected to this junction, the output will switch low when the ramp exceeds $2/3$ of the input voltage. The junction's voltage ramps down toward ground while the output is low. When the ramp is below $1/3$ of the input voltage, the output switches to high, and the junction ramps up again. The continuing frequency of an MIC1555/7 astable oscillator depends on the RC time constant, and is approximately $0.7/RC$ below 1MHz. At frequencies above 1MHz the RC multiplier increases as capacitance is decreased, and propagation delay becomes dominant. Non-symmetrical oscillator operation is possible at frequencies up to 5MHz.

If a duty cycle other than 50% is desired, a low-power signal diode may be connected in series with the timing resistor (R_A), and a second resistor (R_B) in series with an opposite facing switching diode and resistor connected in parallel (see [Figure 2](#)). The frequency is then made up of two components, the charging time (t_A) and the discharging time (t_B) $t_A = 0.7R_A C_T$ and $t_B = 0.7R_B C_T$. The frequency is the reciprocal of the sum of the two times $t_A + t_B$, so the total time is $1.4R_T C_T$. The first half-cycle of an astable, after power-on or CS enable, is lengthened since the capacitor is charging from ground instead of the $1/3$ input trigger trip voltage, to $1.1RC$, the same as a monostable pulse.

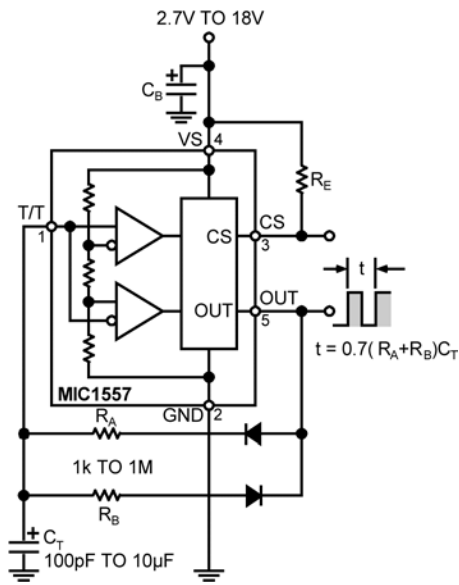

Figure 2. Oscillator Diagram

The MIC1555 or MIC1557 can be used to construct an oscillator.

The frequency of an astable oscillator is:

$$f = \frac{1}{k_1 RC}$$

where:

f = frequency (Hz)

k₁ = Constant (see *Typical Characteristics*)

R = Resistance (Ω)

C = Capacitance (F)

To use the MIC1555 as an oscillator, connect TRG to THR.

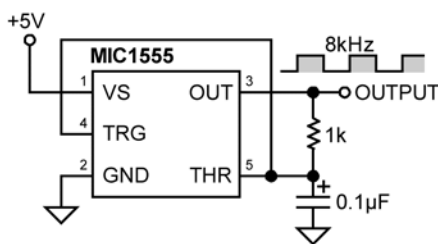

Figure 3. MIC1555 Oscillator Configuration

The MIC1555YMU and MIC1557 feature a CS input. With a logic-low signal, CS places the part into a <1μA shutdown state. If unused, the CS input must be pulled up.

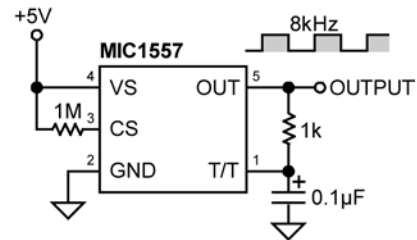

Figure 4. MIC1557 Oscillator Configuration

Falling-Edge Triggered Monostable Circuit

The MIC1555 may be triggered by an AC-coupled falling-edge, as shown in Figure 5. The RC time constant of the input capacitor and pull-up resistor should be less than the output pulse time, to prevent multiple output pulses. A diode across the timing resistor provides a fast reset at the end of the positive timing pulse.

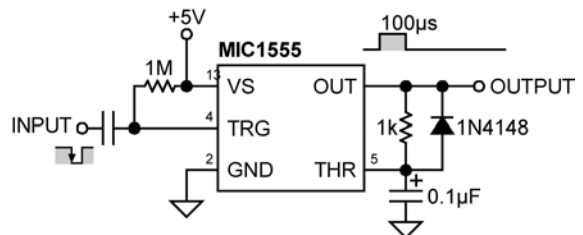

Figure 5. Falling Edge Trigger Configuration

Rising-Edge Triggered Monostable Circuit

The MIC1555 may be triggered by an AC-coupled rising-edge, as shown in Figure 6. The pulse begins when the ac-coupled input rises, and a diode from the output holds the THR input low until TRG discharges to 1/3VS. This circuit provides a low-going output pulse.

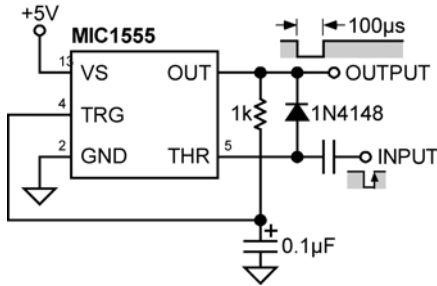

Figure 6. Rising Edge Trigger Configuration

Accuracy

The two comparators in the MIC1555/7 use a resistor voltage divider to set the threshold and trigger trip points to approximately 2/3 and 1/3 of the input voltage, respectively. Since the charge and discharge rates of an RC circuit are dependent on the applied voltage, the timing remains constant if the input voltage varies. If a duty cycle of exactly 50% (or any other value from 1 to 99%), two resistors (or a variable resistor) and two diodes are needed to vary the charge and discharge times. The forward voltage of diodes varies with temperature, so some change in frequency will be seen with temperature extremes, but the duty cycle should track. For absolute timing accuracy, the MIC1555/7 output could be used to control constant current sources to linearly charge and discharge the capacitor, at the expense of added components and board space.

Long Time Delays

Timing resistors larger than 1MΩ or capacitors larger than 10µF are not recommended due to leakage current inaccuracies. Time delays greater than 10 seconds are more accurately produced by dividing the output of an oscillator by a chain of flip-flop counter stages. To produce an accurate one-hour delay, for example, divide a 4.55Hz MIC1557 oscillator by 16,384 (4000hex, 214) using a CD4020 CMOS divider. 4.5Hz may be generated with a 1µF CT and approximately 156kΩ.

Inverting Schmitt Trigger

As shown in Figure 7, the trip points of the MIC1555/7 are defined as 1/3 and 2/3VS, which allows either device to be used as a signal conditioning inverter, with hysteresis. A slowly changing input on T/T will be converted to a fast rise or fall-time opposite direction rail-to-rail output voltage. This output may be used to directly drive the gate of a logic-level P-channel MOSFET with a gate pull-up resistor. This is an inverted logic low-side logic level MOSFET driver. A standard N-channel MOSFET may be driven by a second MIC1555/7, powered by 12V to 15V, to level-shift the input.

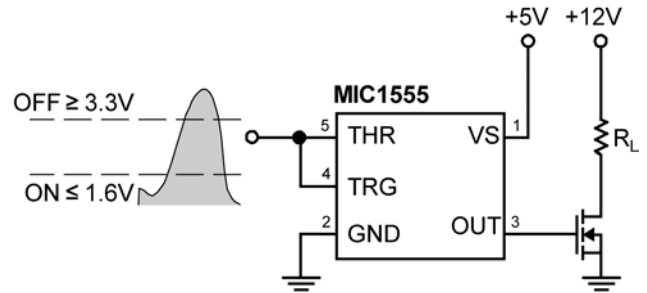

Figure 7. Schmitt Trigger

Charge-Pump Low-Side MOSFET Drivers

A standard MOSFET requires approximately >5V to fully enhance the gate for minimum R_{DS(ON)}. Substituting a logic-level MOSFET reduces the required gate voltage, allowing an MIC1557 to be used as an inverting Schmitt trigger, described above. An MIC1557 may be configured as a voltage quadrupler to boost a 5V input to over 15V to fully enhance an N-channel MOSFET which may have its drain connected to a higher voltage, through a high-side load. ATTL high signal applied to CS enables a 10kHz oscillator, which quickly develops 15V at the gate of the MOSFET, clamped by a Zener diode. A resistor from the gate to ground ensures that the FET will turn off quickly when the MIC1557 is turned off.

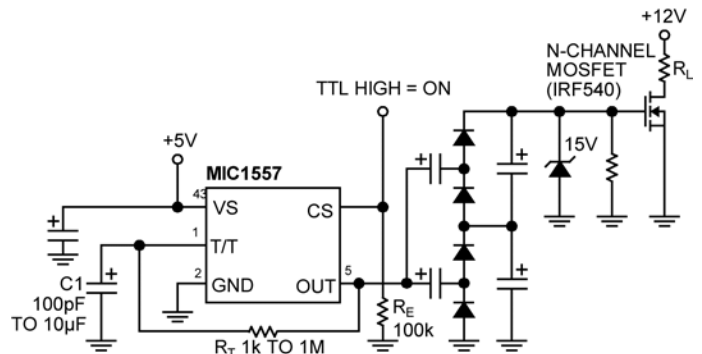

Figure 8. Charge Pump

Audible Voltmeter

If an additional charge or discharge source is connected to the timing capacitor, the frequency may be shifted by turning the source on or off. An MIC1555 oscillator, powered by the circuit under test, may be used to drive a small loud speaker or piezo-electric transducer to provide a medium frequency for an open or high impedance state at the probe. A high tone is generated for a high level, and a lower frequency for a logic low on the probe.

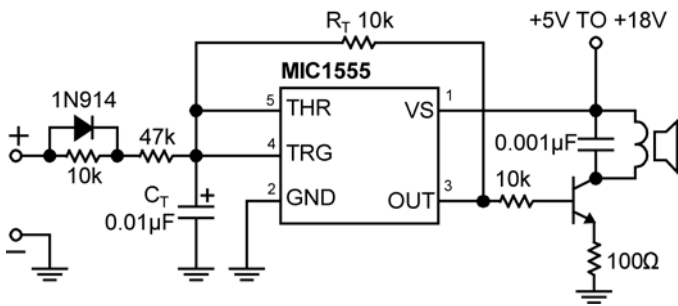
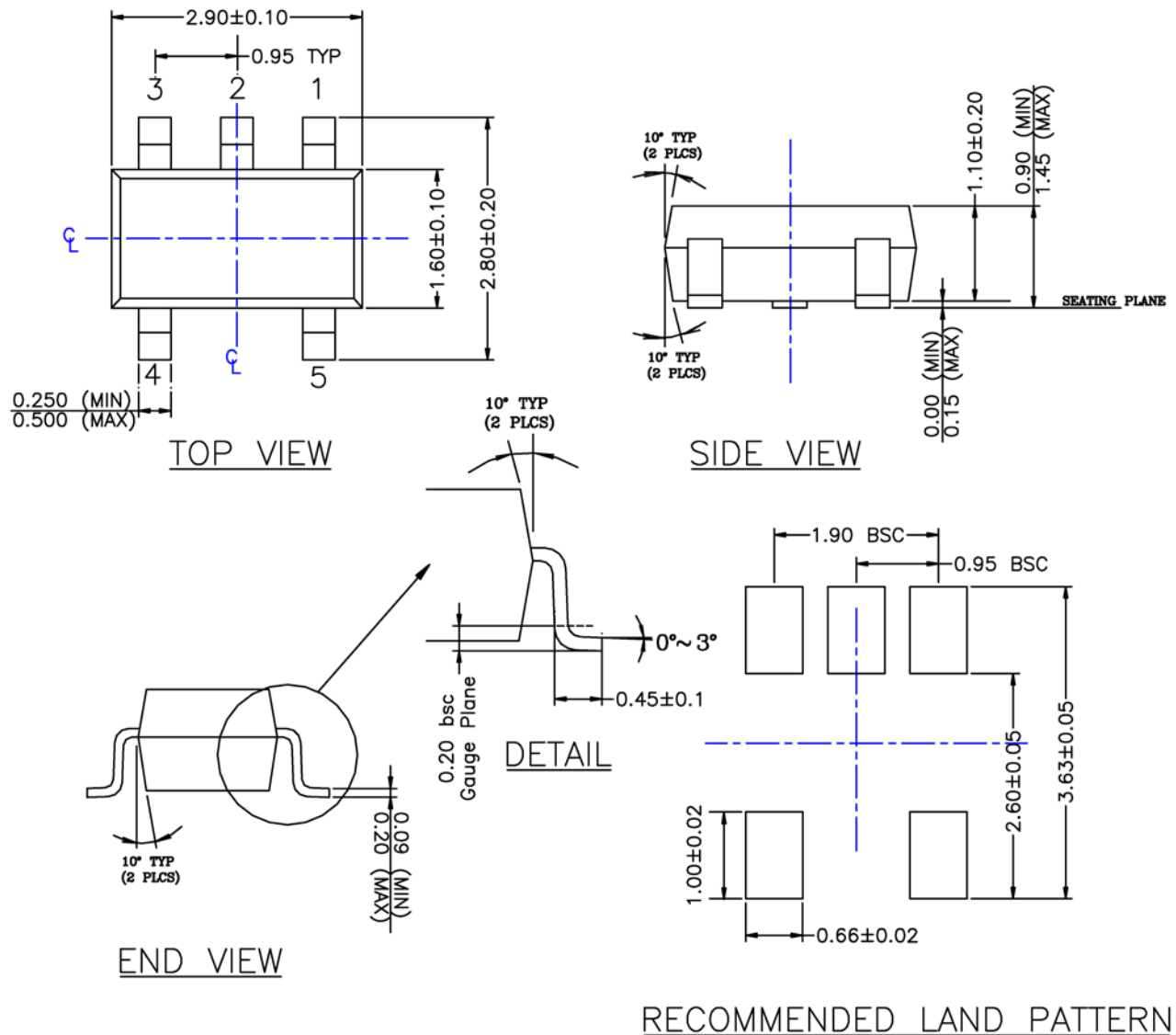

Figure 9. Audible Voltmeter

Package Information and Recommended Land Pattern⁽⁷⁾



- NOTE:
1. PACKAGE OUTLINE EXCLUSIVE OF MOLD FLASH & BURR.
 2. PACKAGE OUTLINE INCLUSIVE OF SOLER PLATING.
 3. DIMENSION AND TOLERANCE PER ANSI Y14.5M, 1982.
 4. FOOT LENGTH MEASUREMENT BASED ON GAUGE PLANE METHOD.
 5. DIE FACES UP FOR MOLD, AND FACES DOWN FOR TRIM/FORM.
 6. ALL DIMENSIONS ARE IN MILLIMETERS.

5-Pin SOT-23 (M5)

Note:

7. Package information is correct as of the publication date. For updates and most current information, go to www.micrel.com.

Package Information and Recommended Land Pattern⁽⁷⁾ (Continued)

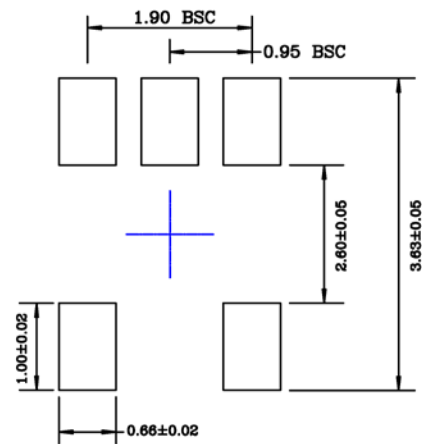
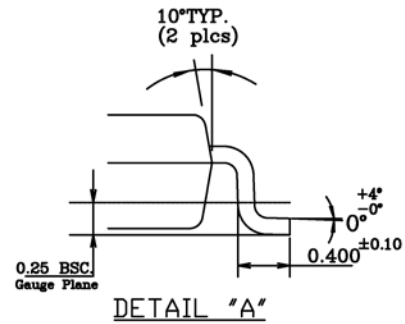
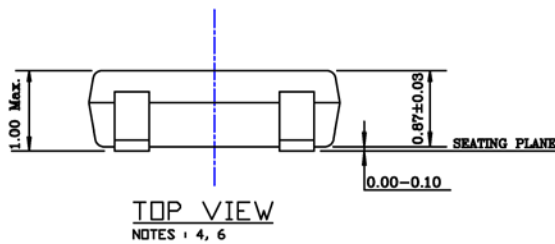
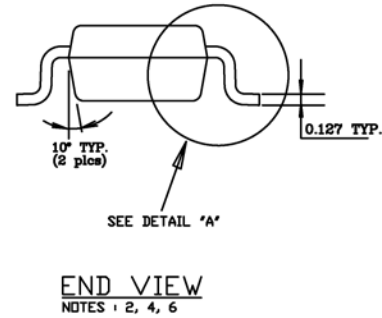
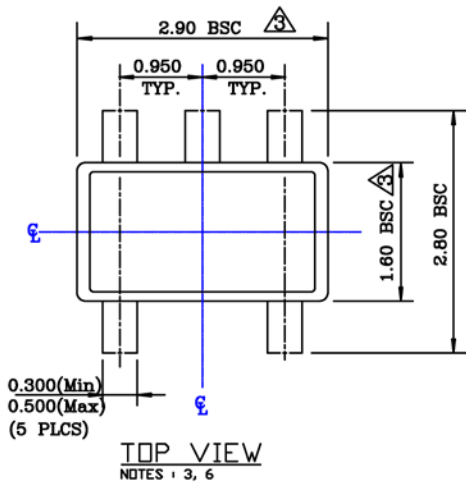

NOTE:

1. Dimensions and tolerances are as per ANSI Y14.5M, 1994.
2. Die is facing up for mold. Die is facing down for trim/form, ie. reverse trim/form.
3. Dimensions are exclusive of mold flash and gate burr.
4. The footlength measuring is based on the gauge plane method.
5. All specification comply to Jedec Spec M0193 Issue C.
6. All dimensions are in millimeters.

5-Pin Thin SOT-23 (D5)

Package Information and Recommended Land Pattern⁽⁷⁾ (Continued)

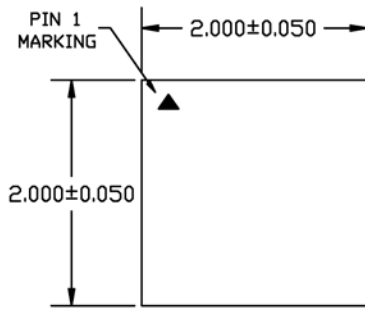

TOP VIEW
NOTE: 1,2,3,4

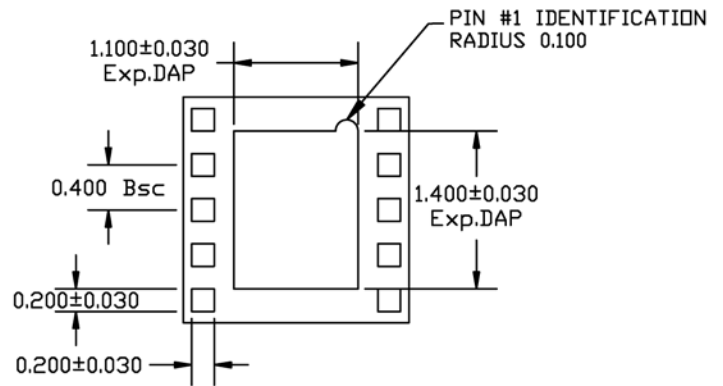

BOTTOM VIEW
NOTE: 1,2,3,4

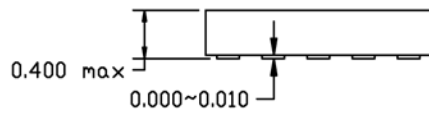

SIDE VIEW
NOTE: 1,2,3,4

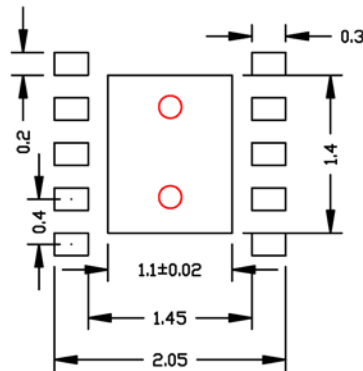

RECOMMENDED LAND PATTERN
NOTE: 5

- NOTE:
1. ALL DIMENSIONS ARE IN MILLIMETERS.
 2. MAX. PACKAGE WARPAGE IS 0.08 mm.
 3. MAXIMUM ALLOWABLE BURRS IS 0.076 mm IN ALL DIRECTIONS.
 4. PIN #1 ID ON TOP WILL BE LASER MARKED.
 5. Red Circle Indicates Thermal Via. Size should be 0.200mm to 0.0350mm in diameter, 0.80mm pitch, and should be connected to ground plane for maximum thermal performance.

10-Pin 2mm x 2mm UTDFN (MU)

MICREL, INC. 2180 FORTUNE DRIVE SAN JOSE, CA 95131 USA
TEL +1 (408) 944-0800 FAX +1 (408) 474-1000 WEB <http://www.micrel.com>

Micrel, Inc. is a leading global manufacturer of IC solutions for the worldwide high performance linear and power, LAN, and timing & communications markets. The Company's products include advanced mixed-signal, analog & power semiconductors; high-performance communication, clock management, MEMs-based clock oscillators & crystal-less clock generators, Ethernet switches, and physical layer transceiver ICs. Company customers include leading manufacturers of enterprise, consumer, industrial, mobile, telecommunications, automotive, and computer products. Corporation headquarters and state-of-the-art wafer fabrication facilities are located in San Jose, CA, with regional sales and support offices and advanced technology design centers situated throughout the Americas, Europe, and Asia. Additionally, the Company maintains an extensive network of distributors and reps worldwide.

Micrel makes no representations or warranties with respect to the accuracy or completeness of the information furnished in this datasheet. This information is not intended as a warranty and Micrel does not assume responsibility for its use. Micrel reserves the right to change circuitry, specifications and descriptions at any time without notice. No license, whether express, implied, arising by estoppel or otherwise, to any intellectual property rights is granted by this document. Except as provided in Micrel's terms and conditions of sale for such products, Micrel assumes no liability whatsoever, and Micrel disclaims any express or implied warranty relating to the sale and/or use of Micrel products including liability or warranties relating to fitness for a particular purpose, merchantability, or infringement of any patent, copyright, or other intellectual property right.

Micrel Products are not designed or authorized for use as components in life support appliances, devices or systems where malfunction of a product can reasonably be expected to result in personal injury. Life support devices or systems are devices or systems that (a) are intended for surgical implant into the body or (b) support or sustain life, and whose failure to perform can be reasonably expected to result in a significant injury to the user. A Purchaser's use or sale of Micrel Products for use in life support appliances, devices or systems is a Purchaser's own risk and Purchaser agrees to fully indemnify Micrel for any damages resulting from such use or sale.

© 2004 Micrel, Incorporated.