

DDR4 DIMM Temperature Sensor with EEPROM for SPD

Features

- Meets JEDEC Specification
 - MCP98244 --> JC42.4-TSE2004B1 Temperature Sensor with 4 Kbit Serial EEPROM for Serial Presence Detect (SPD)
- 1MHz, 2-wire I²C™ Interface
- Specified V_{DD} Range: 1.7V to 3.6V
- Operating Current: 100 µA (typ., EEPROM Idle)
- Available Package: TDFN-8

Temperature Sensor Features

- Temperature-to-Digital Converter (°C)
- Sensor Accuracy (Grade B):
 - **±0.2°C/±1°C (typ./max.)** → **+75°C to +95°C**
 - ±0.5°C/±2°C (typ./max.) → +40°C to +125°C
 - ±1°C/±3°C (typ./max.) → -40°C to +125°C

Serial EEPROM Features

- Operating Current:
 - Write → 250 µA (typical) for 3 ms (typical)
 - Read → 100 µA (typical)
- Reversible Software Write Protect
- Software Write Protection for each 1 Kbit Block
- Organized as two banks of 256 x 8-bit (2 Kbit x 2)

Typical Applications

- DIMM Modules for Servers, PCs, and Laptops
- Temperature Sensing for Solid State Drive (SSD)
- General Purpose Temperature Datalog

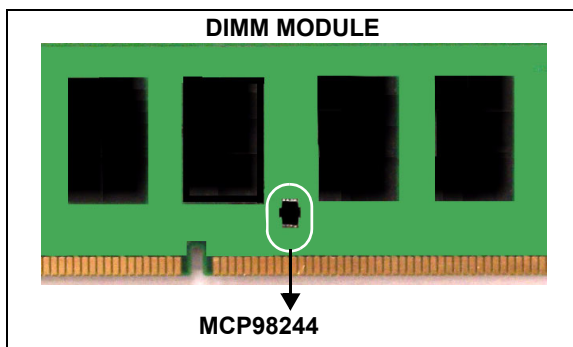

Description

Microchip Technology Inc.'s MCP98244 digital temperature sensor converts temperature from -40°C and +125°C to a digital word. This sensor meets JEDEC Specification JC42.4-TSE3000B1 Memory Module Thermal Sensor Component. It provides an accuracy of ±0.2°C/±1°C (typical/maximum) from +75°C to +95°C with an operating voltage of 1.7V to 3.6V. In addition, MCP98244 has an integrated EEPROM with two banks of 256 by 8 bit EEPROM (4k Bit) which can be used to store memory module details and vendor information.

The MCP98244 digital temperature sensor comes with user-programmable registers that provide flexibility for DIMM temperature-sensing applications. The registers allow user-selectable settings such as Shutdown or Low-Power modes and the specification of temperature Event boundaries. When the temperature changes beyond the specified Event boundary limits, the MCP98244 outputs an Alert signal at the Event pin. The user has the option of setting the temperature Event output signal polarity as either an active-low or active-high comparator output for thermostat operation, or as a temperature Event interrupt output for microprocessor-based systems.

The MCP98244 EEPROM is designed specifically for DRAM DIMMs (Dual In-line Memory Modules) Serial Presence Detect (SPD). It has four 128 Byte pages, which can be Software Write Protected individually. This allows DRAM vendor and product information to be stored and write-protected.

This sensor has an industry standard I²C Fast Mode Plus compatible 1 MHz serial interface.

Package Types

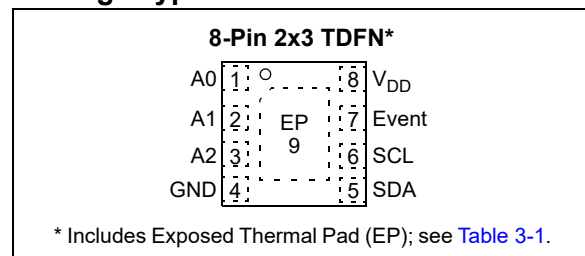

MCP98244

NOTES:

1.0 ELECTRICAL CHARACTERISTICS

Absolute Maximum Ratings †

V _{DD}	4.0V
Voltage at all Input/Output pins	GND – 0.3V to 4.0V
Pin A0.....	GND – 0.3V to 11V
Storage temperature	-65°C to +150°C
Ambient temp. with power applied	-40°C to +125°C
Junction Temperature (T _J).....	+150°C
ESD protection on all pins (HBM:MM)	(4 kV:200V)
Latch-Up Current at each pin (25°C)	±200 mA

†**Notice:** Stresses above those listed under “Maximum ratings” may cause permanent damage to the device. This is a stress rating only and functional operation of the device at those or any other conditions above those indicated in the operational listings of this specification is not implied. Exposure to maximum rating conditions for extended periods may affect device reliability.

TEMPERATURE SENSOR DC CHARACTERISTICS

Electrical Specifications: Unless otherwise indicated, V _{DD} = 1.7V to 3.6V, GND = Ground, and T _A = -40°C to +125°C.						
Parameters	Sym	Min	Typ	Max	Unit	Conditions
Temperature Sensor Accuracy						
+75°C < T _A ≤ +95°C	T _{ACY}	-1.0	±0.2	+1.0	°C	JC42.4 - TSE2004B1 Grade B Accuracy Specification V _{DD} = 1.7V to 3.6V
+40°C < T _A ≤ +125°C		-2.0	±0.5	+2.0	°C	
-40°C < T _A ≤ +125°C		-3.0	±1	+3.0	°C	
Temperature Conversion Time						
0.5°C/bit	t _{CONV}	—	30	—	ms	15 s/sec (typical) (See Section 5.2.4)
0.25°C/bit		—	65	125	ms	
0.125°C/bit		—	130	—	ms	
0.0625°C/bit		—	260	—	ms	
Power Supply						
Specified Voltage Range	V _{DD}	1.7	—	3.6	V	
Operating Current	I _{DD_TS}	—	100	500	µA	EEPROM Inactive
Shutdown Current	I _{SHDN}	—	0.2	1	µA	EEPROM Inactive, I ² C Bus Inactive, T _A = 85°C
Power On Reset (POR)	V _{POR}	—	1.4	1.6	V	Threshold for rising and falling V _{DD}
Settling Time after POR	t _{POR}	—	—	1	ms	For warm and cold power cycles
Line Regulation	Δ°C	—	0.2	—	°C	V _{DD} = 1.7V to 3.6V
Event Output (Open-Drain output, external pull-up resistor required), see Section 5.2.3						
High-Level Current (leakage)	I _{OH}	—	—	1	µA	V _{OH} = V _{DD}
Low-Level Voltage	V _{OL}	—	—	0.4	V	I _{OL} = 3 mA (Active-Low, Pull-up Resistor)
Thermal Response, from +25°C (Air) to +125°C (oil bath)						
TDFN-8	t _{RES}	—	0.7	—	s	Time to 63% (89°C)

MCP98244

MCP98244 EEPROM DC CHARACTERISTICS

Electrical Specifications: Unless otherwise indicated, $V_{DD} = 1.7V$ to $3.6V$, GND = Ground, and $T_A = -40^{\circ}C$ to $+125^{\circ}C$.

Parameters	Sym	Min	Typ	Max	Unit	Conditions
Current, EEPROM write (for t_{WC})	$I_{DD\ EE}$	—	250	2000	μA	Sensor in Shutdown mode
Current, EEPROM read	$I_{DD\ EE}$	—	100	500	μA	
Write Cycle time (byte/page)	t_{WC}	—	3	5	ms	
Endurance $T_A = +25^{\circ}C$	—	—	1M	—	cycles	Write Cycles, $V_{DD} = 3.3V$ (Note 1, Note 2)
EEPROM Write Temperature	EE_{WRITE}	0	—	85	$^{\circ}C$	
EEPROM Read Temperature	EE_{READ}	-40	—	125	$^{\circ}C$	For minimum read temperature, see Note 1
Write Protect Voltage						
SWP and CWP Voltage	V_{HV}	7	—	10	V	Applied at A0 pin

Note 1: Characterized but not production tested.

2: For endurance estimates in a specific application, please consult the Total Endurance™ Model, which can be obtained from Microchip's web site at www.microchip.com/TotalEndurance.

INPUT/OUTPUT PIN DC CHARACTERISTICS

Electrical Specifications: Unless otherwise indicated, $V_{DD} = 1.7V$ to $3.6V$, GND = Ground and $T_A = -40^{\circ}C$ to $+125^{\circ}C$.

Parameters	Sym	Min	Typ	Max	Units	Conditions
Serial Input/Output (SCL, SDA, A0, A1, A2)						
Input						
High-Level Voltage	V_{IH}	$0.7V_{DD}$	—	—	V	
Low-Level Voltage	V_{IL}	—	—	$0.3V_{DD}$	V	
Input Current	I_{IN}	—	—	± 5	μA	SDA and SCL only
Input Impedance (A0, A1, A2)	Z_{IN}	—	1	—	$M\Omega$	$V_{IN} > V_{IH}$
Input Impedance (A0, A1, A2)	Z_{IN}	—	200	—	$k\Omega$	$V_{IN} < V_{IL}$
Output (SDA only)						
Low-Level Voltage	V_{OL}	—	—	0.4	V	$I_{OL} = 3\text{ mA}$
High-Level Current (leakage)	I_{OH}	—	—	1	μA	$V_{OH} = V_{DD}$
Low-Level Current	I_{OL}	20	—	—	mA	$V_{OL} = 0.4V; V_{DD} \geq 2.2V$
		6	—	—	mA	$V_{OL} = 0.6V$
Capacitance	C_{IN}	—	5	—	pF	
SDA and SCL Inputs						
Hysteresis	V_{HYST}	—	$0.05V_{DD}$	—	V	
Spike Suppression	T_{SP}	—	—	50	ns	

TEMPERATURE CHARACTERISTICS

Electrical Specifications: Unless otherwise indicated, $V_{DD} = 1.7V$ to $3.6V$, GND = Ground, and $T_A = -40^{\circ}C$ to $+125^{\circ}C$.

Parameters	Sym	Min	Typ	Max	Units	Conditions
Temperature Ranges						
Specified Temperature Range	T_A	-40	—	+125	$^{\circ}C$	Note 1
Operating Temperature Range	T_A	-40	—	+125	$^{\circ}C$	
Storage Temperature Range	T_A	-65	—	+150	$^{\circ}C$	
Thermal Package Resistances						
Thermal Resistance, 8L-TDFN	θ_{JA}	—	52.5	—	$^{\circ}C/W$	

Note 1: Operation in this range must not cause T_J to exceed Maximum Junction Temperature ($+150^{\circ}C$).

SERIAL INTERFACE TIMING SPECIFICATIONS

Electrical Specifications: Unless otherwise indicated, GND = Ground, $T_A = -40^{\circ}\text{C}$ to $+125^{\circ}\text{C}$, and $C_L = 80\text{ pF}$ (Note 1).

		$V_{DD} = 1.7\text{V to }3.6\text{V}$		$V_{DD} = 2.2\text{V to }3.6\text{V}$				Units
		100 kHz		400 kHz		1000 KHz		
Parameters	Sym	Min	Max	Min	Max	Min	Max	
2-Wire I²C Interface								
Serial port frequency (Note 2, 4)	f_{SCL}	10	100	10	400	10	1000	kHz
Low Clock (Note 2)	t_{LOW}	4700	—	1300	—	500	—	ns
High Clock	t_{HIGH}	4000	—	600	—	260	—	ns
Rise time (Note 5)	t_R	—	1000	20	300	—	120	ns
Fall time (Note 5)	t_F	20	300	20	300	—	120	ns
Data in Setup time (Note 3)	$t_{SU:DAT}$	250	—	100	—	50	—	ns
Data in Hold time (Note 6)	$t_{HD:DI}$	0	—	0	—	0	—	ns
Data out Hold time (Note 4)	$t_{HD:DO}$	200	900	200	900	0	350	ns
Start Condition Setup time	$t_{SU:STA}$	4700	—	600	—	260	—	ns
Start Condition Hold time	$t_{HD:STA}$	4000	—	600	—	260	—	ns
Stop Condition Setup time	$t_{SU:STO}$	4000	—	600	—	260	—	ns
Bus Idle/Free	t_{B-FREE}	4700	—	1300	—	500	—	ns
Time out	t_{OUT}	25	35	25	35	25	35	ms
Bus Capacitive load	C_b	—	—	—	400	—	100	pf

Note 1: All values referred to $V_{IL\text{ MAX}}$ and $V_{IH\text{ MIN}}$ levels.

- If $t_{LOW} > t_{OUT}$, the temperature sensor I²C interface will time out. A Repeat Start command is required for communication.
- This device can be used in a Standard-mode I²C-bus system, but the requirement $t_{SU:DAT} \geq 250\text{ ns}$ must be met. This device does not stretch SCL Low period. It outputs the next data bit to the SDA line within $t_R\text{ MAX} + t_{SU:DAT\text{ MIN}} = 1000\text{ ns} + 250\text{ ns} = 1250\text{ ns}$ (according to the Standard-mode I²C-bus specification) before the SCL line is released.
- As a transmitter, the device provides internal minimum delay time $t_{HD:DAT\text{ MIN}}$ to bridge the undefined region (min. 200 ns) of the falling edge of SCL $t_F\text{ MAX}$ to avoid unintended generation of Start or Stop conditions.
- Characterized but not production tested.
- As a receiver, SDA should not be sampled at the falling edge of SCL. SDA can transition $t_{HD:DI}$ 0 ns after SCL toggles Low.

TIMING DIAGRAM

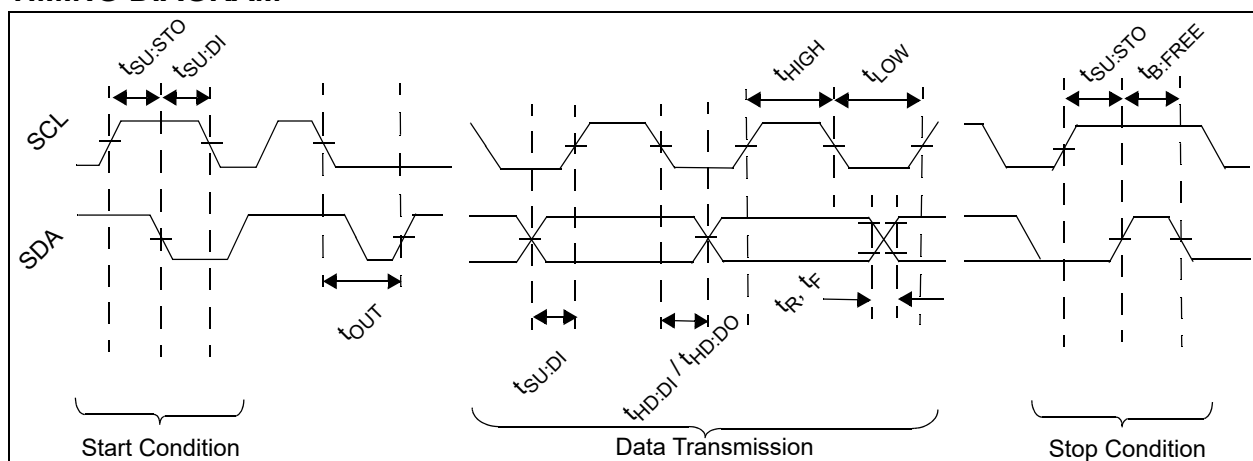

MCP98244

2.0 TYPICAL PERFORMANCE CURVES

Note: The graphs and tables provided following this note are a statistical summary based on a limited number of samples and are provided for informational purposes only. The performance characteristics listed herein are not tested or guaranteed. In some graphs or tables, the data presented may be outside the specified operating range (e.g., outside specified power supply range) and therefore outside the warranted range.

Note: Unless otherwise indicated, $V_{DD} = 1.7V$ to $3.6V$, GND = Ground, SDA/SCL pulled-up to V_{DD} , and $T_A = -40^{\circ}C$ to $+125^{\circ}C$.

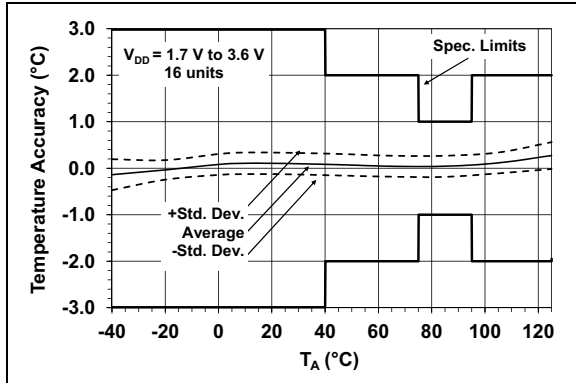

FIGURE 2-1: Temperature Accuracy.

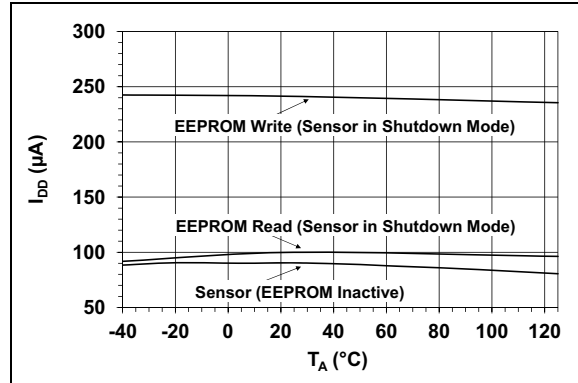

FIGURE 2-4: Supply Current Vs. Temperature.

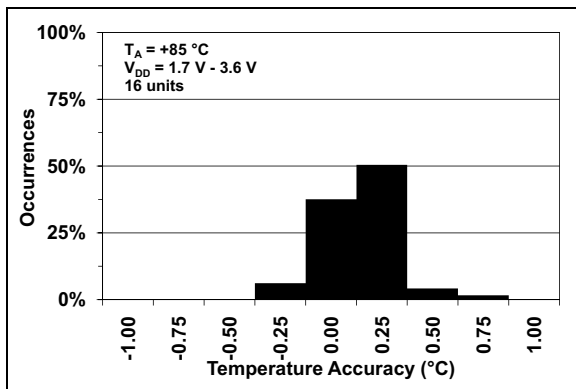

FIGURE 2-2: Temperature Accuracy Histogram, $T_A = +85^{\circ}C$.

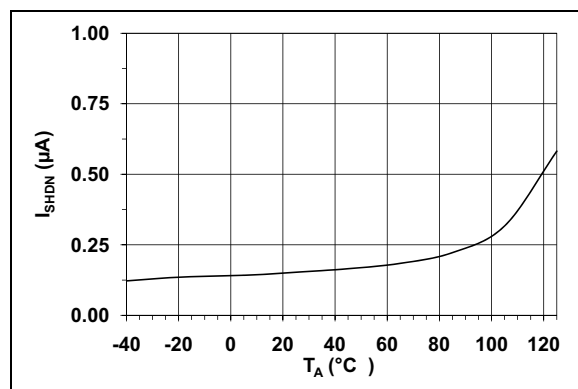

FIGURE 2-5: Shutdown Current Vs. Temperature.

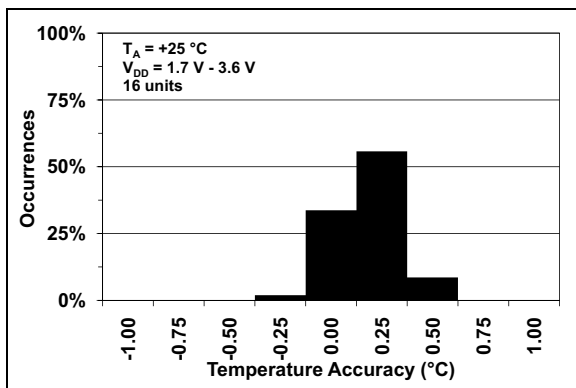

FIGURE 2-3: Temperature Accuracy Histogram, $T_A = +25^{\circ}C$.

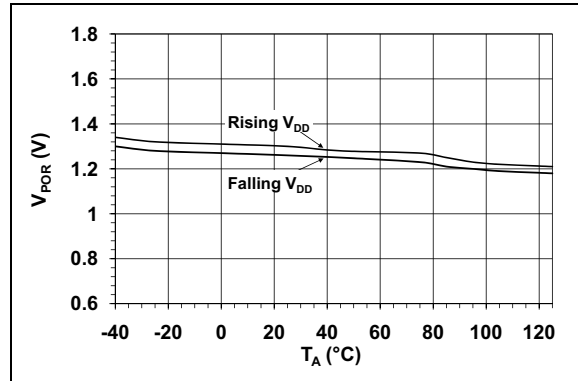

FIGURE 2-6: Power On Reset Threshold Voltage Vs. Temperature.

Note: Unless otherwise indicated, $V_{DD} = 1.7\text{V}$ to 3.6V , GND = Ground, SDA/SCL pulled-up to V_{DD} , and $T_A = -40^\circ\text{C}$ to $+125^\circ\text{C}$.

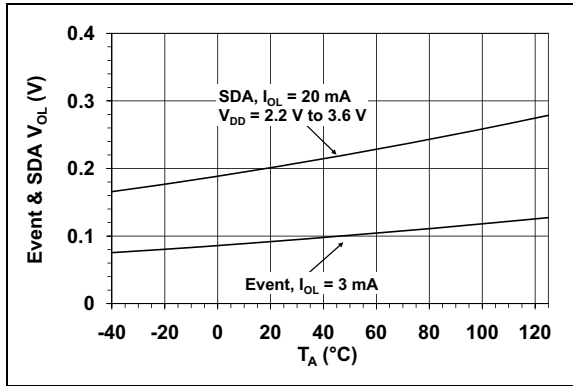

FIGURE 2-7: Event Output and SDA V_{OL} Vs. Temperature.

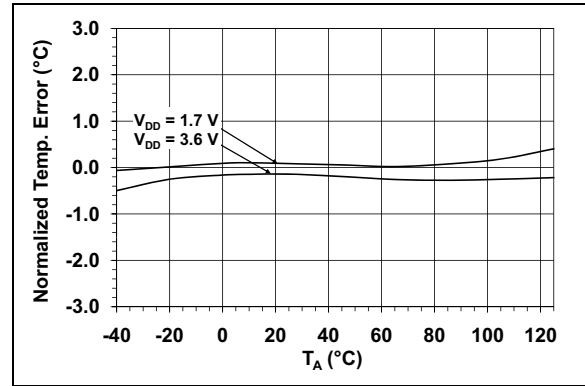

FIGURE 2-10: Line Regulation: Change in Temperature Accuracy Vs. Change in V_{DD} .

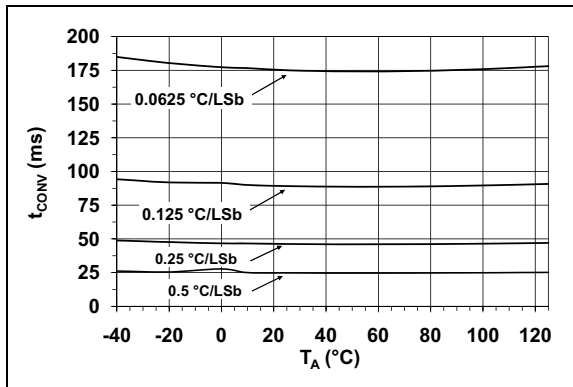

FIGURE 2-8: Temperature Conversion Rate Vs. Temperature.

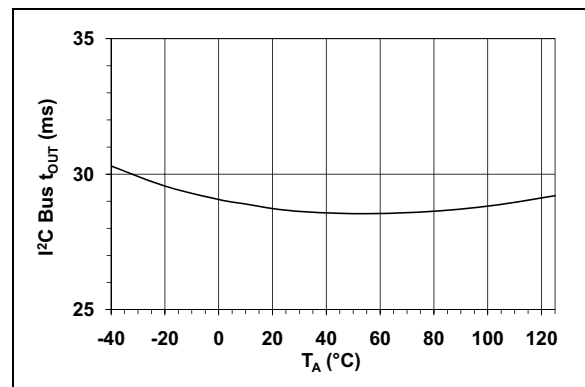

FIGURE 2-11: I^2C Protocol Time-out Vs. Temperature.

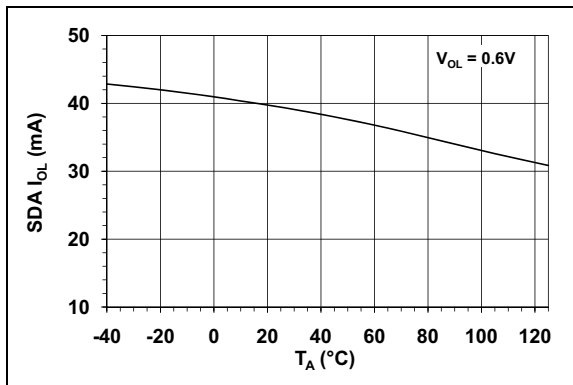

FIGURE 2-9: SDA I_{OL} Vs. Temperature.

MCP98244

3.0 PIN DESCRIPTION

The descriptions of the pins are listed in [Table 3-1](#).

TABLE 3-1: PIN FUNCTION TABLES

MCP98244	Symbol	Description
TDFN		
1	A0	Client Address and EEPROM Software Write Protect High Voltage Input (V_{HV})
2	A1	Client Address
3	A2	Client Address
4	GND	Ground
5	SDA	Serial Data Line
6	SCL	Serial Clock Line
7	Event	Temperature Alert Output
8	V_{DD}	Power Pin
9	EP	Exposed Thermal Pad (EP); can be connected to GND.

3.1 Address Pins (A0, A1, A2)

These pins are device address input pins.

The address pins correspond to the Least Significant bits (LSb) of address bits. The Most Significant bits (MSb) are (A6, A5, A4, A3). This is shown in [Table 3-2](#).

TABLE 3-2: MCP98244 ADDRESS BYTE

Device	Address Code				Client Address		
	A6	A5	A4	A3	A2	A1	A0
Sensor	0	0	1	1	X ¹	X ¹	X ¹
EEPROM	1	0	1	0			
EEPROM Write Protect	0	1	1	0	— ²	— ²	— ²

Note 1: User-selectable address is shown by X, where X is 1 or 0 for V_{DD} and GND, respectively.

2: The address pins are ignored for all Write Protect commands.

The A0 Address pin is a multi-function pin. This input pin is also used for high voltage input V_{HV} to enable the EEPROM Software Write Protect feature, for more information see [Section 5.3.3 “Bank or page selection for EEPROM Read/write operation”](#).

All address pin have an internal pull-down resistors.

3.2 Ground Pin (GND)

The GND pin is the system ground pin.

3.3 Serial Data Line (SDA)

SDA is a bidirectional input/output pin, used to serially transmit data to/from the host controller. This pin requires a pull-up resistor. (See [Section 4.0 “Serial Communication”](#)).

3.4 Serial Clock Line (SCL)

The SCL is a clock input pin. All communication timing is relative to the signal on this pin. The clock is generated by the host or host controller on the bus. (See [Section 4.0 “Serial Communication”](#)).

3.5 Temperature Alert, Open-Drain Output (Event)

The MCP98244 temperature Event output pin is an open-drain output. The device outputs a signal when the ambient temperature goes beyond the user-programmed temperature limit. (see [Section 5.2.3 “Event Output Configuration”](#)).

3.6 Power Pin (V_{DD})

V_{DD} is the power pin. The operating voltage range, as specified in the DC electrical specification table, is applied on this pin.

3.7 Exposed Thermal Pad (EP)

There is an internal electrical connection between the Exposed Thermal Pad (EP) and the GND pin; they can be connected to the same potential on the Printed Circuit Board (PCB). This provides better thermal conduction from the PCB to the die.

4.0 SERIAL COMMUNICATION

4.1 2-Wire Standard Mode I²C™ Protocol-Compatible Interface

The MCP98244 serial clock input (SCL) and the bidirectional serial data line (SDA) form a 2-wire bidirectional Standard mode I²C-compatible communication port (refer to the [Input/Output Pin DC Characteristics](#) table and [Serial Interface Timing Specifications](#) table).

The following bus protocol has been defined:

TABLE 4-1: MCP98244 SERIAL BUS PROTOCOL DESCRIPTIONS

Term	Description
Host	The device that controls the serial bus, typically a microcontroller.
Client	The device addressed by the host, such as the MCP98244 .
Transmitter	Device sending data to the bus.
Receiver	Device receiving data from the bus.
START	A unique signal from host to initiate serial interface with a client.
STOP	A unique signal from the host to terminate serial interface from a client.
Read/Write	A read or write to the MCP98244 registers.
ACK	A receiver Acknowledges (ACK) the reception of each byte by polling the bus.
NAK	A receiver Not-Acknowledges (NAK) or releases the bus to show End-of-Data (EOD).
Busy	Communication is not possible because the bus is in use.
Not Busy	The bus is in the idle state, both SDA and SCL remain high.
Data Valid	SDA must remain stable before SCL becomes high in order for a data bit to be considered valid. During normal data transfers, SDA only changes state while SCL is low.

4.1.1 DATA TRANSFER

Data transfers are initiated by a Start condition (START), followed by a 7-bit device address and a read/write bit. An Acknowledge (ACK) from the client confirms the reception of each byte. Each access must be terminated by a Stop condition (STOP).

Repeated communication is initiated after t_{B-FREE} .

This device does not support sequential register read/write. Each register needs to be addressed using the Register Pointer.

This device supports the Receive Protocol. The register can be specified using the pointer for the initial read. Each repeated read or receive begins with a Start condition and address byte. The MCP98244 retains the previously selected register. Therefore, they output data from the previously-specified register (repeated pointer specification is not necessary).

4.1.2 HOST/CLIENT

The bus is controlled by a host device (typically a microcontroller) that controls the bus access and generates the Start and Stop conditions. The MCP98244 is a client device and does not control other devices in the bus. Both host and client devices can operate as either transmitter or receiver. However, the host device determines which mode is activated.

4.1.3 START/STOP CONDITION

A high-to-low transition of the SDA line (while SCL is high) is the Start condition. All data transfers must be preceded by a Start condition from the host. A low-to-high transition of the SDA line (while SCL is high) signifies a Stop condition.

If a Start or Stop condition is introduced during data transmission, the MCP98244 releases the bus. All data transfers are ended by a Stop condition from the host.

4.1.4 ADDRESS BYTE

Following the Start condition, the host must transmit an 8-bit address byte to the MCP98244. The address for the MCP98244 Temperature Sensor is '0011, A2, A1, A0' in binary, where the A2, A1 and A0 bits are set externally by connecting the corresponding pins to V_{DD} '1' or GND '0'. The 7-bit address transmitted in the serial bit stream must match the selected address for the MCP98244 to respond with an ACK. Bit 8 in the address byte is a read/write bit. Setting this bit to '1' commands a read operation, while '0' commands a write operation (see [Figure 4-1](#)).

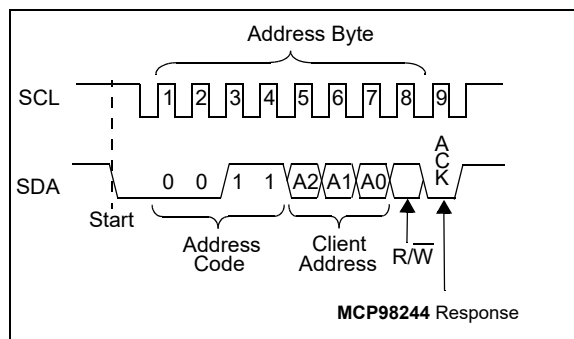

FIGURE 4-1: Device Addressing.

4.1.5 DATA VALID

After the Start condition, each bit of data in transmission needs to be settled for a time specified by $t_{SU-DATA}$ before SCL toggles from low-to-high (see [Serial Interface Timing Specifications](#) table).

MCP98244

4.1.6 ACKNOWLEDGE (ACK/NAK)

Each receiving device, when addressed, is obliged to generate an ACK bit after the reception of each byte. The host device must generate an extra clock pulse for ACK to be recognized.

The acknowledging device pulls down the SDA line for $t_{\text{SU-DATA}}$ before the low-to-high transition of SCL from the host. SDA also needs to remain pulled down for $t_{\text{H-DATA}}$ after a high-to-low transition of SCL.

During read, the host must signal an End-of-Data (EOD) to the client by not generating an ACK bit (NAK) once the last bit has been clocked out of the client. In this case, the client will leave the data line released to enable the host to generate the Stop condition.

4.1.7 TIME OUT (T_{OUT})

If the SCL stays low or high for time specified by t_{OUT} , the MCP98244 resets the serial interface. This dictates the minimum clock speed as indicated in the specification.

5.0 FUNCTIONAL DESCRIPTION

The MCP98244 temperature sensors consists of a band-gap type temperature sensor, a Delta-Sigma Analog-to-Digital Converter ($\Sigma\Delta$ ADC),

user-programmable registers and a 2-wire I²C protocol compatible serial interface. Figure 5-1 shows a block diagram of the register structure.

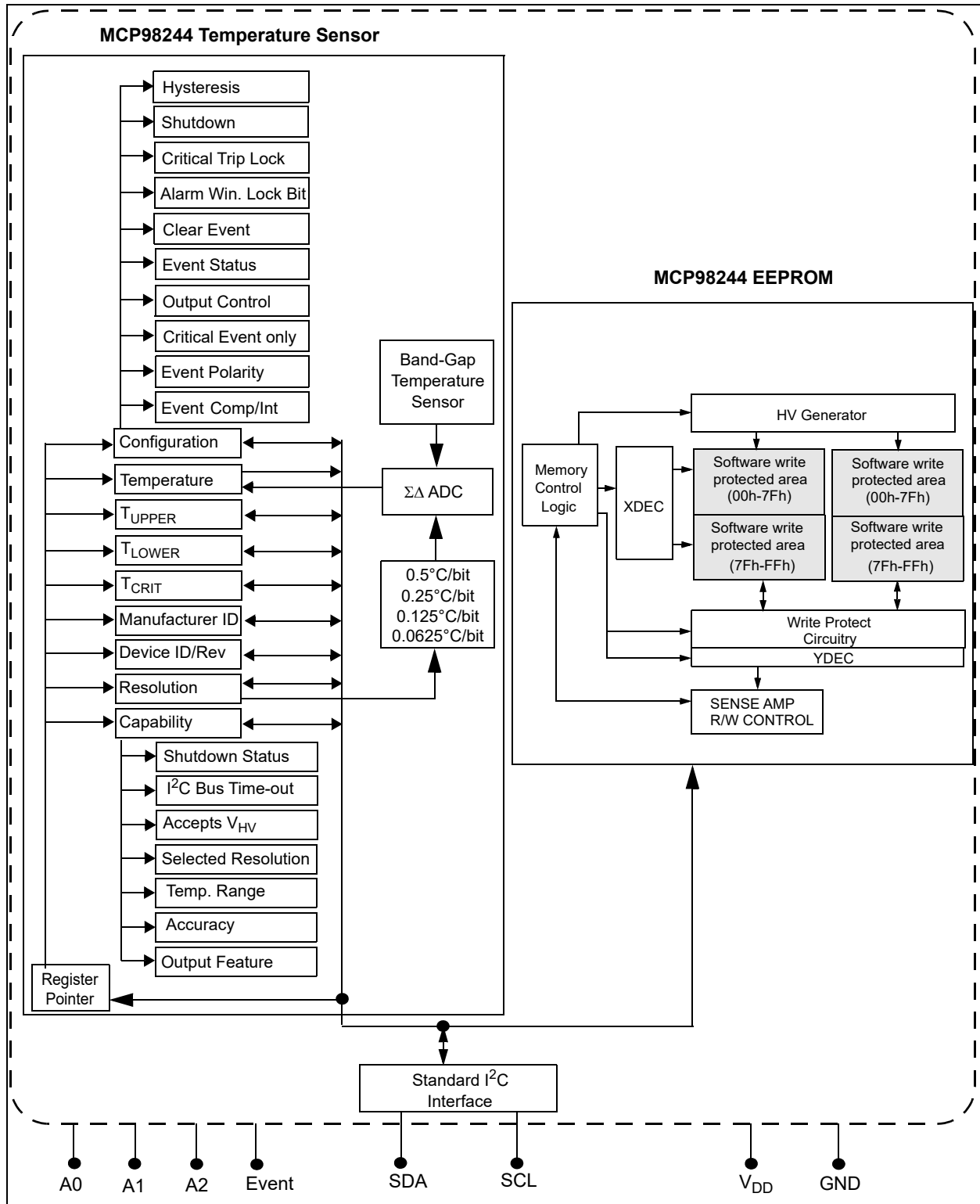

FIGURE 5-1: Functional Block Diagram.

MCP98244

5.1 Registers

The MCP98244 device has several registers that are user-accessible. These registers include the Capability register, Configuration register, Event Temperature Upper-Boundary and Lower-Boundary Trip registers, Critical Temperature Trip register, Temperature register, Manufacturer Identification register and Device Identification register.

The Temperature register is read-only, used to access the ambient temperature data. The data is loaded in parallel to this register after t_{CONV} . The Event Temperature Upper-Boundary and Lower-Boundary Trip registers are read/writes. If the ambient temperature drifts beyond the user-specified limits, the MCP98244 device outputs a signal using the Event pin (refer to [Section 5.2.3 “Event Output Configuration”](#)). In addition, the Critical Temperature Trip register is used to provide an additional critical temperature limit.

The Capability register is used to provide bits describing the MCP98244’s capability in measurement resolution, measurement range and device accuracy. The device Configuration register provides access to configure the MCP98244’s various features. These registers are described in further detail in the following sections.

The registers are accessed by sending a Register Pointer to the MCP98244 using the serial interface. This is an 8-bit write-only pointer, and [Register 5-1](#) describes the pointer assignment.

REGISTER 5-1: REGISTER POINTER (WRITE ONLY)

W-0	W-0	W-0	W-0	W-0	W-0	W-0	W-0
—	—	—	—	Pointer Bits			
bit 7							bit 0

Legend:			
R = Readable bit	W = Writable bit	U = Unimplemented bit, read as ‘0’	
-n = Value at POR	‘1’ = Bit is set	‘0’ = Bit is cleared	x = Bit is unknown

- bit 7-4 **Writable Bits:** Write ‘0’
- bit 3-0 **Pointer Bits:**
 - 0000 =Capability register
 - 0001 =Configuration register (CONFIG)
 - 0010 =Event Temperature Upper-Boundary Trip register (T_{UPPER})
 - 0011 =Event Temperature Lower-Boundary Trip register (T_{LOWER})
 - 0100 =Critical Temperature Trip register (T_{CRIT})
 - 0101 =Temperature register (T_A)
 - 0110 =Manufacturer ID register
 - 0111 =Device ID/Revision register
 - 1000 =TSE2004av Device ID and Vendor Silicon Revision Register
 - 1001 =Resolution register
 - 1XXX =Unused (The device will not acknowledge commands to other pointer locations.)

**TABLE 5-1: BIT ASSIGNMENT SUMMARY FOR ALL TEMPERATURE SENSOR REGISTERS
(SEE SECTION 5.4)**

Register Pointer (Hex)	MSB/LSB	Bit Assignment							
		7	6	5	4	3	2	1	0
0x00	MSB	0	0	0	0	0	0	0	0
	LSB	SHDN Status	t _{OUT} Range	V _{HV}	Resolution		Range	Accuracy	Event
0x01	MSB	0	0	0	0	0	Hysteresis		SHDN
	LSB	Crt Loc	Win Loc	Int Clr	Evt Stat	Evt Cnt	Evt Sel	Evt Pol	Evt Mod
0x02	MSB	0	0	0	SIGN	2 ⁷ °C	2 ⁶ °C	2 ⁵ °C	2 ⁴ °C
	LSB	2 ³ °C	2 ² °C	2 ¹ °C	2 ⁰ °C	2 ⁻¹ °C	2 ⁻² °C	0	0
0x03	MSB	0	0	0	SIGN	2 ⁷ °C	2 ⁶ °C	2 ⁵ °C	2 ⁴ °C
	LSB	2 ³ °C	2 ² °C	2 ¹ °C	2 ⁰ °C	2 ⁻¹ °C	2 ⁻² °C	0	0
0x04	MSB	0	0	0	SIGN	2 ⁷ °C	2 ⁶ °C	2 ⁵ °C	2 ⁴ °C
	LSB	2 ³ °C	2 ² °C	2 ¹ °C	2 ⁰ °C	2 ⁻¹ °C	2 ⁻² °C	0	0
0x05	MSB	T _A ≥ T _{CRIT}	T _A > T _{UPPER}	T _A < T _{LOWER}	SIGN	2 ⁷ °C	2 ⁶ °C	2 ⁵ °C	2 ⁴ °C
	LSB	2 ³ °C	2 ² °C	2 ¹ °C	2 ⁰ °C	2 ⁻¹ °C	2 ⁻² °C	2 ⁻³ °C	2 ⁻⁴ °C
0x06	MSB	0	0	0	0	0	0	0	0
	LSB	0	1	0	1	0	1	0	0
0x07	MSB	0	0	1	0	0	0	1	0
	LSB	0	0	0	0	0	0	0	1
0x08	MSB	0	0	1	0	0	0	1	0
	LSB	0	0	0	0	0	0	0	1
0x09	MSB	0	0	0	0	0	0	0	0
	LSB	0	0	0	0	0	0	Resolution	

MCP98244

5.1.1 CAPABILITY REGISTER

This is a read-only register used to identify the temperature sensor capability. The device capability bit assignments are specified by TSE2004av, and this device is factory configured to meet the default conditions as described in [Register 5-2](#) (these values can not be changed).

For example, the MCP98244 device is capable of providing temperature at 0.25°C resolution, measuring temperature below and above 0°C, providing ±1°C and ±2°C accuracy over the active and monitor temperature ranges (respectively) and providing user-programmable temperature event boundary trip limits.

These functions are described in further detail in the following sections.

REGISTER 5-2: CAPABILITY REGISTER (READ-ONLY) → ADDRESS '0000 0000'b

U-0	U-0	U-0	U-0	U-0	U-0	U-0	U-0
—	—	—	—	—	—	—	—
bit 15							bit 8

R-1	R-1	R-1	R-0	R-1	R-1	R-1	R-1
SHDN Status	t _{OUT} Range	V _{HV}	Resolution	Meas. Range	Accuracy	Temp Alarm	
bit 7							bit 0

Legend:

R = Readable bit W = Writable bit U = Unimplemented bit, read as '0'
 -n = Value at POR '1' = Bit is set '0' = Bit is cleared x = Bit is unknown

bit 15-8 **Unimplemented:** Read as '0'

bit 7 **Event output status during Shutdown (SHDN Status):**

- 0 = Event output remains in previous state. If the output asserts before shutdown command, it remains asserted during shutdown.
- 1 = Event output deasserts during shutdown. After shutdown, it takes t_{CONV} to re-assert the Event output (power-up default)

bit 6 **I²C Bus time-out (t_{OUT} Range):**

- 0 = Bus time-out range is 10 ms to 60 ms
- 1 = Bus time-out range is 25 ms to 35 ms (power-up default)

bit 5 **High Voltage Input**

- 0 = Pin A0 does not accept High Voltage
- 1 = Pin A0 accepts High Voltage for the EEPROM Write Protect feature (power-up default)

bit 4-3 **Resolution:**

- 00 = 0.5°C
- 01 = 0.25°C (power up default)
- 10 = 0.125°C
- 11 = 0.0625°C

These bits reflect the selected resolution (see [Section 5.2.4 "Temperature Resolution"](#))

bit 2 **Temperature Measurement Range (Meas. Range):**

- 0 = T_A = 0 (decimal) for temperature below 0°C
- 1 = The part can measure temperature below 0°C (power-up default)

REGISTER 5-2: CAPABILITY REGISTER (READ-ONLY) → ADDRESS '0000 0000'b (CONTINUED)

- bit 1 **Accuracy:**
 0 = Accuracy → ±2°C from +75°C to +95°C (Active Range) and ±3°C from +40°C to +125°C (Monitor Range)
 1 = Accuracy → ±1°C from +75°C to +95°C (Active Range) and ±2°C from +40°C to +125°C (Monitor Range)
- bit 0 **Temperature Alarm:**
 0 = No defined function (This bit will never be cleared or set to '0.')
- 1 = The part has temperature boundary trip limits (T_{UPPER}/T_{LOWER}/T_{CRIT} registers) and a temperature event output (JC 42.4 required feature)

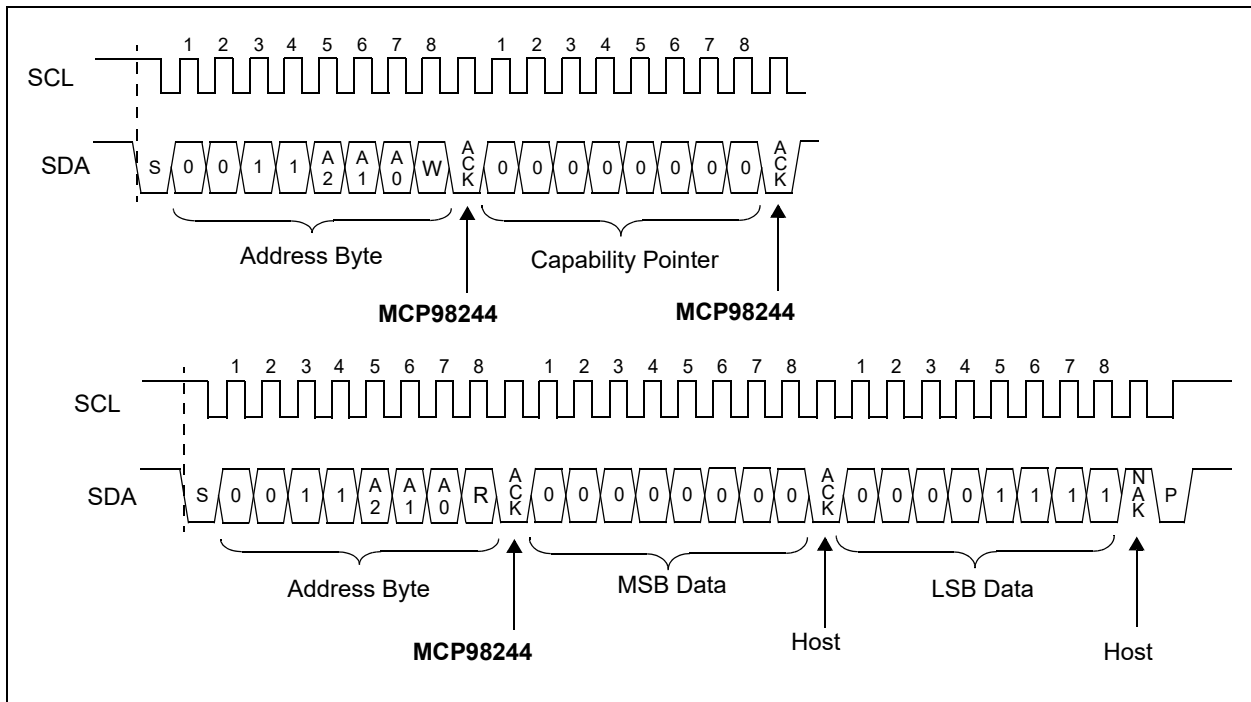

FIGURE 5-2: Timing Diagram for Reading the Capability Register (See [Section 4.0 “Serial Communication”](#)).

MCP98244

5.1.2 SENSOR CONFIGURATION REGISTER (CONFIG)

The MCP98244 device has a 16-bit Configuration register (CONFIG) that allows the user to set various functions for a robust temperature monitoring system. Bits 15 thru 0 are used to select Event output boundary hysteresis, device Shutdown or Low-Power mode, temperature boundary and critical temperature lock, or temperature Event output enable/disable. In addition, the user can select the Event output condition (output set for T_{UPPER} and T_{LOWER} temperature boundary or T_{CRIT} only), read Event output status and set Event output polarity and mode (Comparator Output or Interrupt Output mode).

The temperature hysteresis bits 10 and 9 can be used to prevent output chatter when the ambient temperature gradually changes beyond the user-specified temperature boundary (see [Section 5.2.2 “Temperature Hysteresis \(\$T_{HYST}\$ \)”](#)).

The Continuous Conversion or Shutdown mode is selected using bit 8. In Shutdown mode, the band gap temperature sensor circuit stops converting temperature and the Ambient Temperature register (T_A) holds the previous successfully converted temperature data (see [Section 5.2.1 “Shutdown Mode”](#)). Bits 7 and 6 are used to lock the user-specified boundaries T_{UPPER} , T_{LOWER} and T_{CRIT} to prevent an accidental rewrite. Bits 5 thru 0 are used to configure the temperature Event output pin. All functions are described in [Register 5-3](#) (see [Section 5.2.3 “Event Output Configuration”](#)).

REGISTER 5-3: CONFIGURATION REGISTER (CONFIG) → ADDRESS `0000 0001`_b

U-0	U-0	U-0	U-0	U-0	R/W-0	R/W-0	R/W-0
—	—	—	—	—	T_{HYST}		SHDN
bit 15							bit 8

R/W-0	R/W-0	R/W-0	R-0	R/W-0	R/W-0	R/W-0	R/W-0
Crit. Lock	Win. Lock	Int. Clear	Event Stat.	Event Cnt.	Event Sel.	Event Pol.	Event Mod.
bit 7							bit 0

Legend:			
R = Readable bit	W = Writable bit	U = Unimplemented bit, read as '0'	
-n = Value at POR	'1' = Bit is set	'0' = Bit is cleared	x = Bit is unknown

bit 15-11 **Unimplemented:** Read as '0'

bit 10-9 **T_{UPPER} and T_{LOWER} Limit Hysteresis (T_{HYST}):**

- 00 = 0°C (power-up default)
- 01 = 1.5°C
- 10 = 3.0°C
- 11 = 6.0°C

(Refer to [Section 5.2.3 “Event Output Configuration”](#))

This bit can not be altered when either of the lock bits are set (bit 6 and bit 7).

This bit can be programmed in Shutdown mode.

bit 8 **Shutdown Mode (SHDN):**

- 0 = Continuous Conversion (power-up default)
- 1 = Shutdown (Low-Power mode)

In shutdown, all power-consuming activities are disabled, though all registers can be written to or read. Event output will deassert.

This bit cannot be set '1' when either of the lock bits is set (bit 6 and bit 7). However, it can be cleared '0' for Continuous Conversion while locked (Refer to [Section 5.2.1 “Shutdown Mode”](#)).

**REGISTER 5-3: CONFIGURATION REGISTER (CONFIG) → ADDRESS `0000 0001'b
(CONTINUED)**

bit 7	<p>T_{CRIT} Lock Bit (Crit. Lock): 0 = Unlocked. T_{CRIT} register can be written (power-up default) 1 = Locked. T_{CRIT} register can not be written</p> <p>When enabled, this bit remains set '1' or locked until cleared by internal reset (Section 5.4 “Summary of Power-On Default”). This bit does not require a double-write.</p> <p>This bit can be programmed in Shutdown mode.</p>
bit 6	<p>T_{UPPER} and T_{LOWER} Window Lock Bit (Win. Lock): 0 = Unlocked. T_{UPPER} and T_{LOWER} registers can be written (power-up default) 1 = Locked. T_{UPPER} and T_{LOWER} registers can not be written</p> <p>When enabled, this bit remains set '1' or locked until cleared by power-on Respell (Section 5.4 “Summary of Power-On Default”). This bit does not require a double-write.</p> <p>This bit can be programmed in Shutdown mode.</p>
bit 5	<p>Interrupt Clear (Int. Clear) Bit: 0 = No effect (power-up default) 1 = Clear interrupt output. When read this bit returns '0'</p> <p>This bit clears the Interrupt flag which deasserts Event output. In Shutdown mode, the Event output is always deasserted. Therefore, setting this bit in Shutdown mode clears the interrupt after the device returns to normal operation.</p>
bit 4	<p>Event Output Status (Event Stat.) Bit: 0 = Event output is not asserted by the device (power-up default) 1 = Event output is asserted as a comparator/Interrupt or critical temperature output</p> <p>In Shutdown mode this bit will clear because Event output is always deasserted in Shutdown mode.</p>
bit 3	<p>Event Output Control (Event Cnt.) Bit: 0 = Event output Disabled (power-up default) 1 = Event output Enabled</p> <p>This bit can not be altered when either of the lock bits is set (bit 6 and bit 7).</p> <p>This bit can be programmed in Shutdown mode, but Event output will remain deasserted.</p>
bit 2	<p>Event Output Select (Event Sel.) Bit: 0 = Event output for T_{UPPER}, T_{LOWER} and T_{CRIT} (power-up default) 1 = T_A ≥ T_{CRIT} only. (T_{UPPER} and T_{LOWER} temperature boundaries are disabled.)</p> <p>When this bit is set '1' or T_{CRIT} only is enabled, the Event Output mode asserts and de-asserts in Comparator mode only. Therefore, when bit 2 is set to '1', bit 0 of CONFIG must also be set '0', since the Event output does not operate in the Interrupt mode while the Event Select bit, or only the T_A ≥ T_{CRIT} bit, is enabled (see Figure 5-9).</p> <p>When the Alarm Window Lock bit is set, this bit cannot be altered until unlocked (bit 6).</p> <p>This bit can be programmed in Shutdown mode, but Event output will remain deasserted.</p>
bit 1	<p>Event Output Polarity (Event Pol.) Bit: 0 = Active low (power-up default. Pull-up resistor required) 1 = Active-high</p> <p>This bit cannot be altered when either of the lock bits is set (bit 6 and bit 7).</p> <p>This bit can be programmed in Shutdown mode, but Event output will remain deasserted, see Section 5.2.3 “Event Output Configuration”.</p>
bit 0	<p>Event Output Mode (Event Mod.) Bit: 0 = Comparator output (power-up default) 1 = Interrupt output</p> <p>This bit cannot be altered when either of the lock bits is set (bit 6 and bit 7).</p> <p>This bit can be programmed in Shutdown mode, but Event output will remain deasserted.</p>

MCP98244

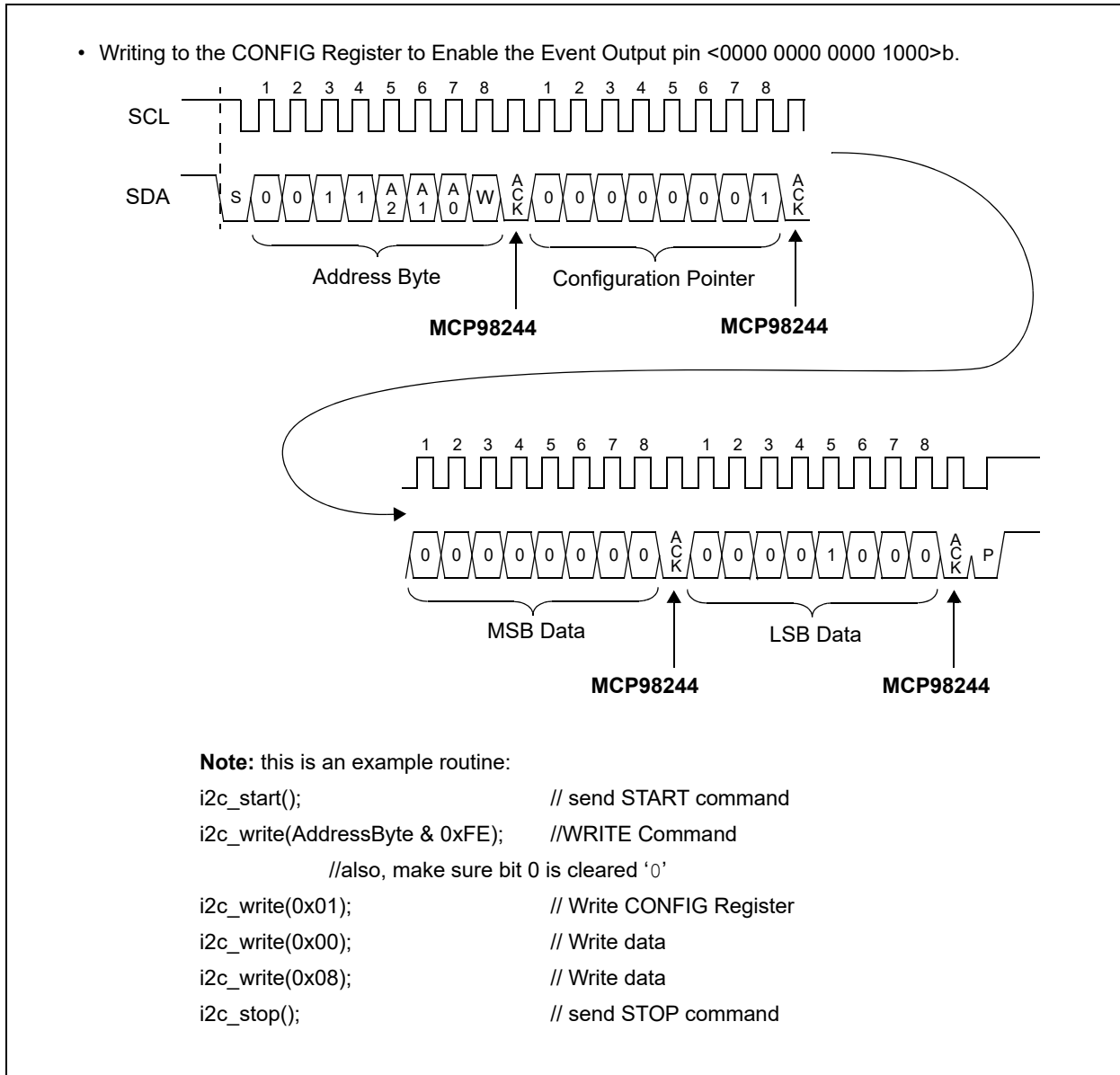

FIGURE 5-3: Timing Diagram for Writing to the Configuration Register (See [Section 4.0 “Serial Communication”](#)).

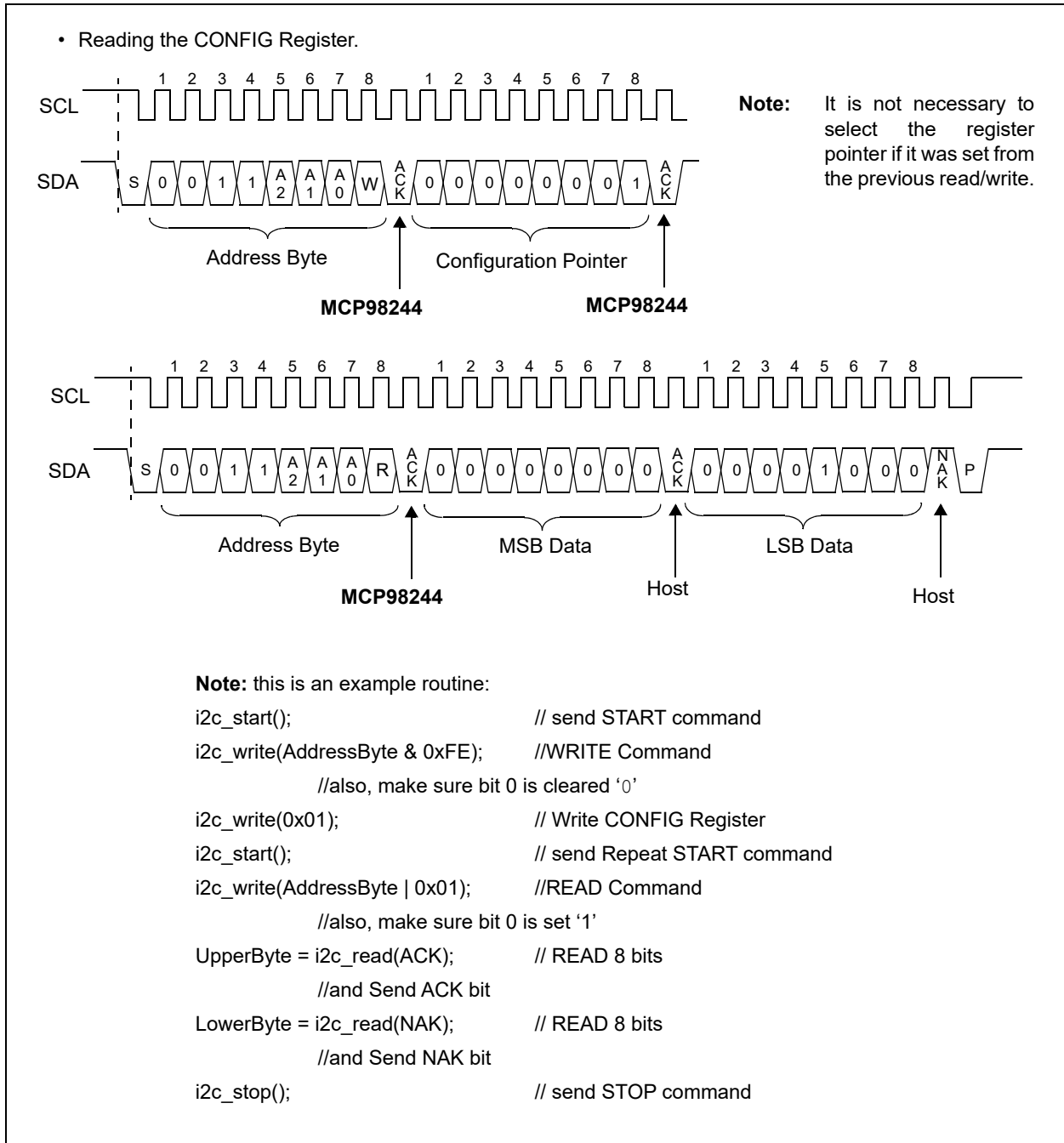

FIGURE 5-4: Timing Diagram for Reading from the Configuration Register (See [Section 4.0](#) “Serial Communication”).

MCP98244

5.1.3 UPPER/LOWER/CRITICAL TEMPERATURE LIMIT REGISTERS ($T_{UPPER}/T_{LOWER}/T_{CRIT}$)

The MCP98244 device has a 16-bit read/write Event output Temperature Upper-Boundary Trip register (T_{UPPER}), a 16-bit Lower-Boundary Trip register (T_{LOWER}) and a 16-bit Critical Boundary Trip register (T_{CRIT}) that contains 11-bit data in two's complement format (0.25°C). This data represents the maximum and minimum temperature boundary or temperature window that can be used to monitor ambient temperature. If this feature is enabled ([Section 5.1.2 “Sensor Configuration Register \(CONFIG\)”](#)) and the ambient temperature exceeds the specified boundary or window, the MCP98244 asserts an Event output. (Refer to [Section 5.2.3 “Event Output Configuration”](#)).

REGISTER 5-4: UPPER/LOWER/CRITICAL TEMPERATURE LIMIT REGISTER

($T_{UPPER}/T_{LOWER}/T_{CRIT}$) → ADDRESS '0000 0010'b/'0000 0011'b/'0000 0100'b
([Note 1](#))

U-0	U-0	U-0	R/W-0	R/W-0	R/W-0	R/W-0	R/W-0	
—	—	—	Sign	2 ⁷ °C	2 ⁶ °C	2 ⁵ °C	2 ⁴ °C	
bit 15								bit 8

R/W-0	R/W-0	R/W-0	R/W-0	R/W-0	R/W-0	U-0	U-0
2 ³ °C	2 ² °C	2 ¹ °C	2 ⁰ °C	2 ⁻¹ °C	2 ⁻² °C	—	—
bit 7						bit 0	

Legend:			
R = Readable bit	W = Writable bit	U = Unimplemented bit, read as '0'	
-n = Value at POR	'1' = Bit is set	'0' = Bit is cleared	x = Bit is unknown

bit 15-13 **Unimplemented:** Read as '0'

bit 12 **Sign:**
0 = $T_A \geq 0^\circ\text{C}$
1 = $T_A < 0^\circ\text{C}$

bit 11-2 **$T_{UPPER}/T_{LOWER}/T_{CRIT}$:**
Temperature boundary trip data in two's complement format.

bit 1-0 **Unimplemented:** Read as '0'

Note 1: This table shows two 16-bit registers for T_{UPPER} , T_{LOWER} and T_{CRIT} located at '0000 0010b', '0000 0011b' and '0000 0100b', respectively.

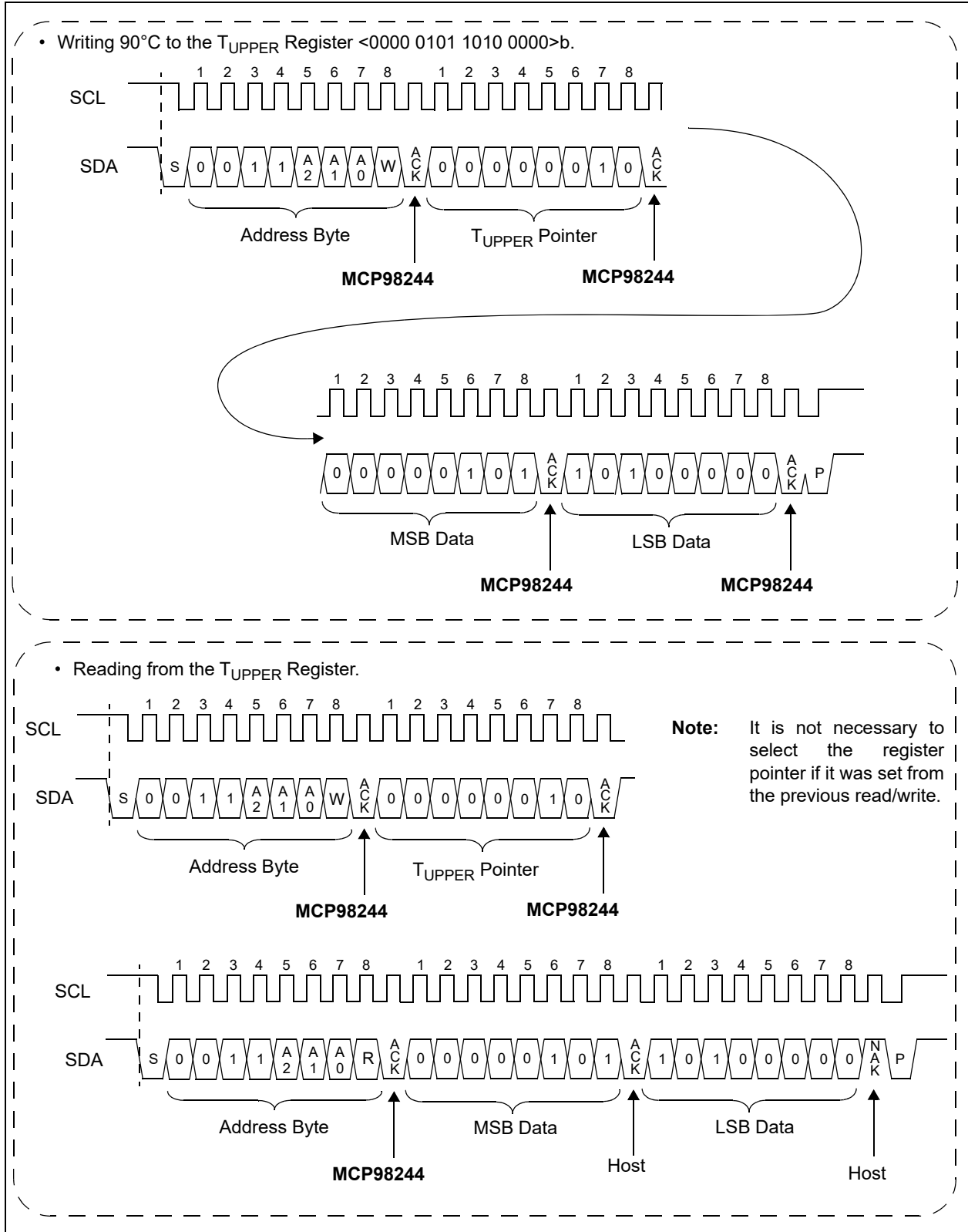

FIGURE 5-5: Timing Diagram for Writing and Reading from the T_{UPPER} Register (See [Section 4.0](#) “Serial Communication”).

MCP98244

5.1.4 AMBIENT TEMPERATURE REGISTER (T_A)

The MCP98244 device uses a band gap temperature sensor circuit to output analog voltage proportional to absolute temperature. An internal $\Delta\Sigma$ ADC is used to convert the analog voltage to a digital word. The converter resolution is set to $0.25^\circ\text{C} + \text{sign}$ (11-bit data). The digital word is loaded to a 16-bit read-only Ambient Temperature register (T_A) that contains 11-bit temperature data in two's complement format.

The T_A register bits (bits 12 through 0) are double-buffered. Therefore, the user can access the register while, in the background, the MCP98244 performs an analog-to-digital conversion. The temperature data from the $\Delta\Sigma$ ADC is loaded in parallel to the T_A register at t_{CONV} refresh rate.

In addition, the T_A register uses three bits (bits 15, 14 and 13) to reflect the Event pin state. This allows the user to identify the cause of the Event output trigger (see [Section 5.2.3 “Event Output Configuration”](#)); bit 15 is set to '1' if T_A is greater than or equal to T_{CRIT} , bit 14 is set to '1' if T_A is greater than T_{UPPER} and bit 13 is set to '1' if T_A is less than T_{LOWER} .

The T_A register bit assignment and boundary conditions are described in [Register 5-5](#).

REGISTER 5-5: AMBIENT TEMPERATURE REGISTER (T_A) → ADDRESS '0000 0101'b (Note 1)

R-0	R-0	R-0	R-0	R-0	R-0	R-0	R-0
T_A vs. T_{CRIT}	T_A vs. T_{UPPER}	T_A vs. T_{LOWER}	SIGN	2^7 °C	2^6 °C	2^5 °C	2^4 °C
bit 15							bit 8

R-0	R-0	R-0	R-0	R-0	R-0	R-0	R-0
2^3 °C	2^2 °C	2^1 °C	2^0 °C	2^{-1} °C	2^{-2} °C	2^{-3} °C	2^{-4} °C
bit 7							bit 0

Legend:			
R = Readable bit	W = Writable bit	U = Unimplemented bit, read as '0'	
-n = Value at POR	'1' = Bit is set	'0' = Bit is cleared	x = Bit is unknown

bit 15 **T_A vs. T_{CRIT} Bit: (Note 1)**

0 = $T_A < T_{\text{CRIT}}$
1 = $T_A \geq T_{\text{CRIT}}$

bit 14 **T_A vs. T_{UPPER} Bit: (Note 1):**

0 = $T_A \leq T_{\text{UPPER}}$
1 = $T_A > T_{\text{UPPER}}$

bit 13 **T_A vs. T_{LOWER} Bit: (Note 1):**

0 = $T_A \geq T_{\text{LOWER}}$
1 = $T_A < T_{\text{LOWER}}$

bit 12 **SIGN Bit:**

0 = $T_A \geq 0^\circ\text{C}$
1 = $T_A < 0^\circ\text{C}$

bit 11-0 **Ambient Temperature (T_A) Bits: (Note 2)**

12-bit Ambient Temperature data in two's complement format.

Note 1: Bits 15, 14 and 13 are not affected by the status of the Event output configuration (bits 5 to 0 of CONFIG) ([Register 5-3](#)).

2: Bits 2, 1, and 0 may remain clear '0' depending on the status of the resolution register. The Power-up default is $0.25^\circ\text{C}/\text{bit}$, bits 1 and 0 remain clear '0'.

5.1.4.1 T_A bits to Temperature Conversion

To convert the T_A bits to decimal temperature, the upper three boundary bits (15, 14 and 13) must be masked out. Then determine the sign bit (bit 12) to check positive or negative temperature, shift the bits accordingly and combine the upper and lower bytes of the 16-bit register. The upper byte contains data for temperatures greater than 32°C, while the lower byte contains data for temperature less than 32°C, including fractional data. When combining the upper and lower bytes, the upper byte must be Right-shifted by 4 bits (or multiply by 2^4) and the lower byte must be Left-shifted by 4 bits (or multiply by 2^{-4}). Adding the results of the shifted values provides the temperature data in decimal format; see Equation 5-1.

The temperature bits are in two's complement format, therefore, positive temperature data and negative temperature data are computed differently. Equation 5-1 shows the temperature computation. The example instruction code outlined in Figure 5-6 shows the communication flow, also see Figure 5-7 for timing diagram.

EQUATION 5-1: BYTES TO TEMPERATURE CONVERSION

Temperature $\geq 0^\circ\text{C}$ (bit 12 or Sign bit = 0)

$$T_A = (\text{UpperByte} \times 2^4 + \text{LowerByte} \times 2^{-4})$$

Temperature $< 0^\circ\text{C}$ (bit 12 or Sign bit = 1)

$$T_A = (\text{UpperByte} \times 2^4 + \text{LowerByte} \times 2^{-4}) - 256$$

Where:

T_A = Ambient Temperature ($^\circ\text{C}$)

UpperByte = T_A bit 11 to bit 8

LowerByte = T_A bit 7 to bit 0

This example routine assumes the variables and I²C communication subroutines are predefined:

```

i2c_start(); // send START command
i2c_write(AddressByte & 0xFE); //WRITE Command
//also, make sure bit 0 is cleared '0'
i2c_write(0x05); // Write TA Register Address
i2c_start(); //Repeat START
i2c_write(AddressByte | 0x01); // READ Command
//also, make sure bit 0 is Set '1'
UpperByte = i2c_read(ACK); // READ 8 bits
//and Send ACK bit
LowerByte = i2c_read(NAK); // READ 8 bits
//and Send NAK bit
i2c_stop(); // send STOP command
//Convert the temperature data
//First Check flag bits
if ((UpperByte & 0x80) == 0x80){ //TA ≥ TCRIT
}
if ((UpperByte & 0x40) == 0x40){ //TA > TUPPER
}
if ((UpperByte & 0x20) == 0x20){ //TA < TLOWER
}
UpperByte = UpperByte & 0x1F; //Clear flag bits
if ((UpperByte & 0x10) == 0x10){ //TA < 0°C
UpperByte = UpperByte & 0x0F; //Clear SIGN
Temperature = 256 - (UpperByte x 16 + LowerByte / 16);
}else //TA ≥ 0°C
Temperature = (UpperByte x 16 + LowerByte / 16);
//Temperature = Ambient Temperature (°C)

```

FIGURE 5-6: Example Instruction Code.

MCP98244

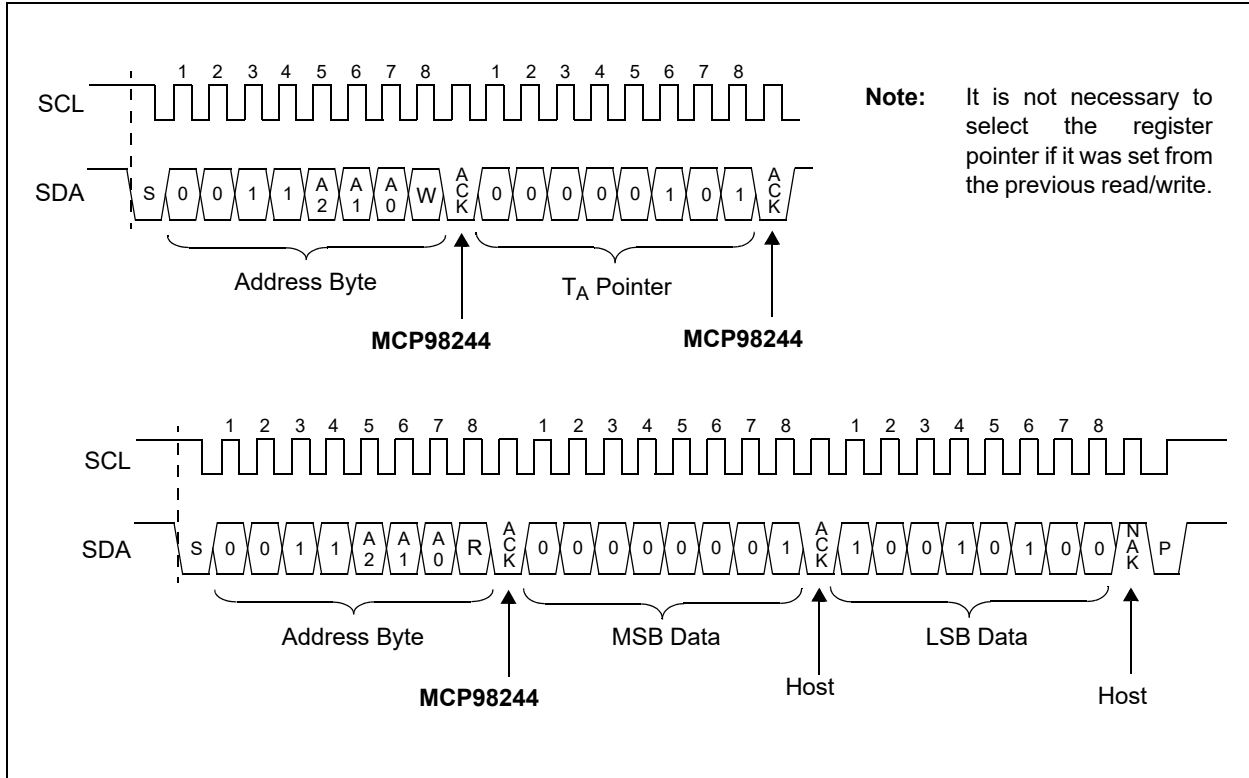

FIGURE 5-7: Timing Diagram for Reading +25.25°C Temperature from the T_A Register (See Section 4.0 “Serial Communication”).

5.1.5 MANUFACTURER ID REGISTER

This register is used to identify the manufacturer of the device in order to perform manufacturer specific operation. The Manufacturer ID for the MCP98244 is 0x0054 (hexadecimal).

REGISTER 5-6: MANUFACTURER ID REGISTER (READ-ONLY) → ADDRESS '0000 0110'b

R-0	R-0	R-0	R-0	R-0	R-0	R-0	R-0
Manufacturer ID							
bit 15				bit 8			

R-0	R-1	R-0	R-1	R-0	R-1	R-0	R-0
Manufacturer ID							
bit 7				bit 0			

Legend:

R = Readable bit W = Writable bit U = Unimplemented bit, read as '0'
 -n = Value at POR '1' = Bit is set '0' = Bit is cleared x = Bit is unknown

bit 15-0 **Device Manufacturer Identification Number**

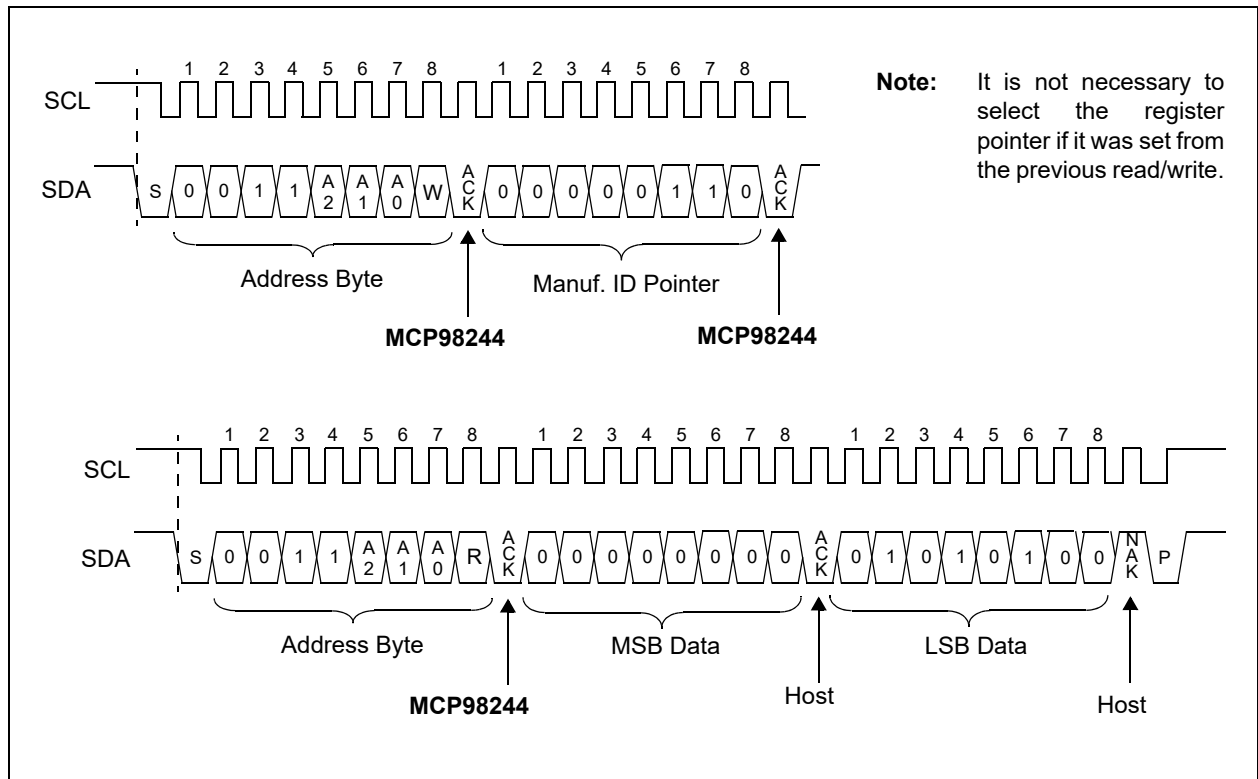

FIGURE 5-8: Timing Diagram for Reading the Manufacturer ID Register (See [Section 4.0 "Serial Communication"](#)).

MCP98244

5.1.6 DEVICE ID AND REVISION REGISTER

There are two Device ID and Revision ID registers. Address pointer 0x07 is specific to TSE2004av devices and it is used to identify compliant devices. Address Pointer 0x08 is a Microchip-specific register and it is used to identify Microchip devices. The upper byte of these registers is used to specify the device identification and the lower byte is used to specify device silicon revision. The device ID for the MCP98244 is 0x22 (hex) (same as TSE2004av).

The revision (Lower Byte) begins with 0x00 (hex) for the first release, with the number being incremented as revised versions are released.

REGISTER 5-7: TSE2004AV DEVICE ID AND DEVICE REVISION (READ-ONLY) → ADDRESS '0000 0111'b AND '0000 1000'b

R-0	R-0	R-1	R-0	R-0	R-0	R-1	R-0
Device ID							
bit 15				bit 8			

R-0	R-0	R-0	R-0	R-0	R-0	R-0	R-1
Device Revision							
bit 7				bit 0			

Legend:

R = Readable bit

W = Writable bit

U = Unimplemented bit, read as '0'

-n = Value at POR

'1' = Bit is set

'0' = Bit is cleared

x = Bit is unknown

bit 15-8 **Device ID:** Bit 15 to bit 8 are used for device ID

bit 7-0 **Device Revision:** Bit 7 to bit 0 are used for device revision

5.1.7 RESOLUTION REGISTER

This register allows the user to change the sensor resolution (see [Section 5.2.4 “Temperature Resolution”](#)). The POR default resolution is 0.25°C. The selected resolution is also reflected in the Capability register (see [Register 5-2](#)).

Note: In order to prevent accidentally writing the resolution register to higher resolution and exceeding the maximum temperature conversion time of $t_{CONV} = 125$ ms, a Shutdown Command (using the CONFIG register) is required to change the resolution register. The device must be in shutdown mode to change the resolution.

REGISTER 5-8: RESOLUTION REGISTER → '0000 1001' b

R/W-1	U-0	U-0	U-0	U-0	U-0	U-0	U-0	
—								
bit 15								bit 8

U-0	U-0	U-0	U-0	U-0	U-0	R/W-0	R/W-1
Resolution							
bit 7							bit 0

Legend:

R = Readable bit	W = Writable bit	U = Unimplemented bit, read as '0'	
-n = Value at POR	'1' = Bit is set	'0' = Bit is cleared	x = Bit is unknown

bit 15 **Unimplemented:** Read as '1'

bit 14-2 **Unimplemented:** Read as '0'

bit 1-0 **Resolution:**

00 =LSB = 0.5°C ($t_{CONV} = 23$ ms typical)

01 =LSB = 0.25°C (power up default, $t_{CONV} = 46$ ms typical)

10 =LSB = 0.125°C ($t_{CONV} = 75$ ms typical)

11 =LSB = 0.0625°C ($t_{CONV} = 150$ ms typical)

5.2 SENSOR FEATURE DESCRIPTION

5.2.1 SHUTDOWN MODE

Shutdown mode disables all power-consuming activities (including temperature sampling operations) while leaving the serial interface active. This mode is selected by setting bit 8 of CONFIG to '1'. In this mode, the device consumes I_{SHDN} . It remains in this mode until bit 8 is cleared '0' to enable Continuous Conversion mode, or until power is recycled.

The Shutdown bit (bit 8) cannot be set to '1' while bits 6 and 7 of CONFIG (Lock bits) are set to '1'. However, it can be cleared '0' or returned to Continuous Conversion while locked.

In Shutdown mode, all registers can be read or written. However, the serial bus activity increases the shutdown current.

If the device is shutdown while the Event pin is asserted, then the Event output will be deasserted during shutdown. It will remain deasserted until the device is enabled for normal operation. Once the device is enabled, it takes t_{CONV} before the device reasserts the Event output.

5.2.2 TEMPERATURE HYSTERESIS (T_{HYST})

A hysteresis of 0°C, 1.5°C, 3°C or 6°C can be selected for the T_{UPPER} , T_{LOWER} and T_{CRIT} temperature boundaries using bits 10 and 9 of CONFIG. The hysteresis applies for decreasing temperature only (hot to cold), or as temperature drifts below the specified limit.

The hysteresis bits can not be changed if either of the lock bits, bits 6 and 7 of CONFIG, are set to '1'.

The T_{UPPER} , T_{LOWER} and T_{CRIT} boundary conditions are described graphically in [Figure 5-9](#).

5.2.3 EVENT OUTPUT CONFIGURATION

The Event output can be enabled using bit 3 of CONFIG (Event output control bit) and can be configured as either a comparator output or as Interrupt Output mode using bit 0 of CONFIG (Event mode). The polarity can also be specified as active-high or active-low using bit 1 of CONFIG (Event polarity). The Event output requires a pull-up resistor to function.

These configurations are designed to serve processors with Low-to-High or High-to-Low edge triggered inputs. With Active-High configuration, when the Event output deasserts, power will be dissipated across the pull-up resistor.

When the ambient temperature increases above the critical temperature limit, the Event output is forced to a comparator output (regardless of bit 0 of CONFIG). When the temperature drifts below the critical temperature limit minus hysteresis, the Event output automatically returns to the state specified by bit 0 of CONFIG.

The status of the Event output can be read using bit 4 of CONFIG (Event status). This bit can not be set to '1' in Shutdown mode.

Bits 7 and 6 of the CONFIG register can be used to lock the T_{UPPER} , T_{LOWER} and T_{CRIT} registers. The bits prevent false triggers at the Event output due to an accidental rewrite to these registers.

The Event output can also be used as a critical temperature output using bit 2 of CONFIG (critical output only). When this feature is selected, the Event output becomes a comparator output. In this mode, the Event Output mode (bit 0 of CONFIG) must be in Comparator mode.

5.2.3.1 Comparator Mode

Comparator mode is selected using bit 0 of CONFIG. In this mode, the Event output is asserted as active-high or active-low using bit 1 of CONFIG. [Figure 5-9](#) shows the conditions that toggle the Event output.

If the device enters Shutdown mode with asserted Event output, the output will deassert. It will remain deasserted until the device enters Continuous Conversion mode and after the first temperature conversion is completed, t_{CONV} . After the initial temperature conversion, T_A must satisfy the T_{UPPER} or T_{LOWER} boundary conditions in order for Event output to be asserted.

Comparator mode is useful for thermostat-type applications, such as turning on a cooling fan or triggering a system shutdown when the temperature exceeds a safe operating range.

5.2.3.2 Interrupt Mode

In the Interrupt mode, the Event output is asserted as active-high or active-low (depending on the polarity configuration) when T_A drifts above or below T_{UPPER} and T_{LOWER} limits. The output is deasserted by setting bit 5 (Interrupt Clear) of CONFIG. If the device enters Shutdown mode with asserted Event output, the output will deassert. It will remain deasserted until the device enters Continuous Conversion mode and after the first temperature conversion is completed, t_{CONV} . If the interrupt clear bit (Bit 5) is never set, then the Event output will reassert after the first temperature conversion.

In addition, if $T_A \geq T_{CRIT}$ the Event output is forced as Comparator mode and asserts until $T_A < T_{CRIT} - T_{HYST}$. While the Event output is asserted, the user must send the Clear Interrupt command (bit 5 of CONFIG) for Event output to deassert, when temperature drops below the critical limit, $T_A < T_{CRIT} - T_{HYST}$. Otherwise, Event output remains asserted (see [Figure 5-9](#) for a graphical description). Switching from Interrupt mode to Comparator mode also deasserts Event output.

This mode is designed for interrupt-driven microcontroller-based systems. The microcontroller receiving the interrupt will have to acknowledge the interrupt by setting bit 5 of CONFIG register from the MCP98244.

5.2.4 TEMPERATURE RESOLUTION

The MCP98244 device is capable of providing temperature data with 0.5°C to 0.0625°C resolution. The Resolution can be selected using the Resolution register ([Register 5-8](#)) which is located in address '00001001'b. This address location is not specified in JEDEC Standard JC42.4. However, it provides additional flexibility while being functionally compatible with JC42.4 and provides a 0.25°C resolution at 125 ms (max.). In order to prevent accidentally changing the resolution and exceeding the 125 ms conversion time, the device must be in Shutdown mode to change this register. The selected resolution can be read by user using bit 4 and bit 3 of the Capability register ([Register 5-2](#)). A 0.25°C resolution is set as POR default by factory.

TABLE 5-2: TEMPERATURE CONVERSION TIME

Resolution	t_{CONV} (ms)	Samples/sec (typical)
0.5°C	30	33
0.25°C (Power-up default)	65	15
0.125°C	130	8
0.0625°C	260	4

MCP98244

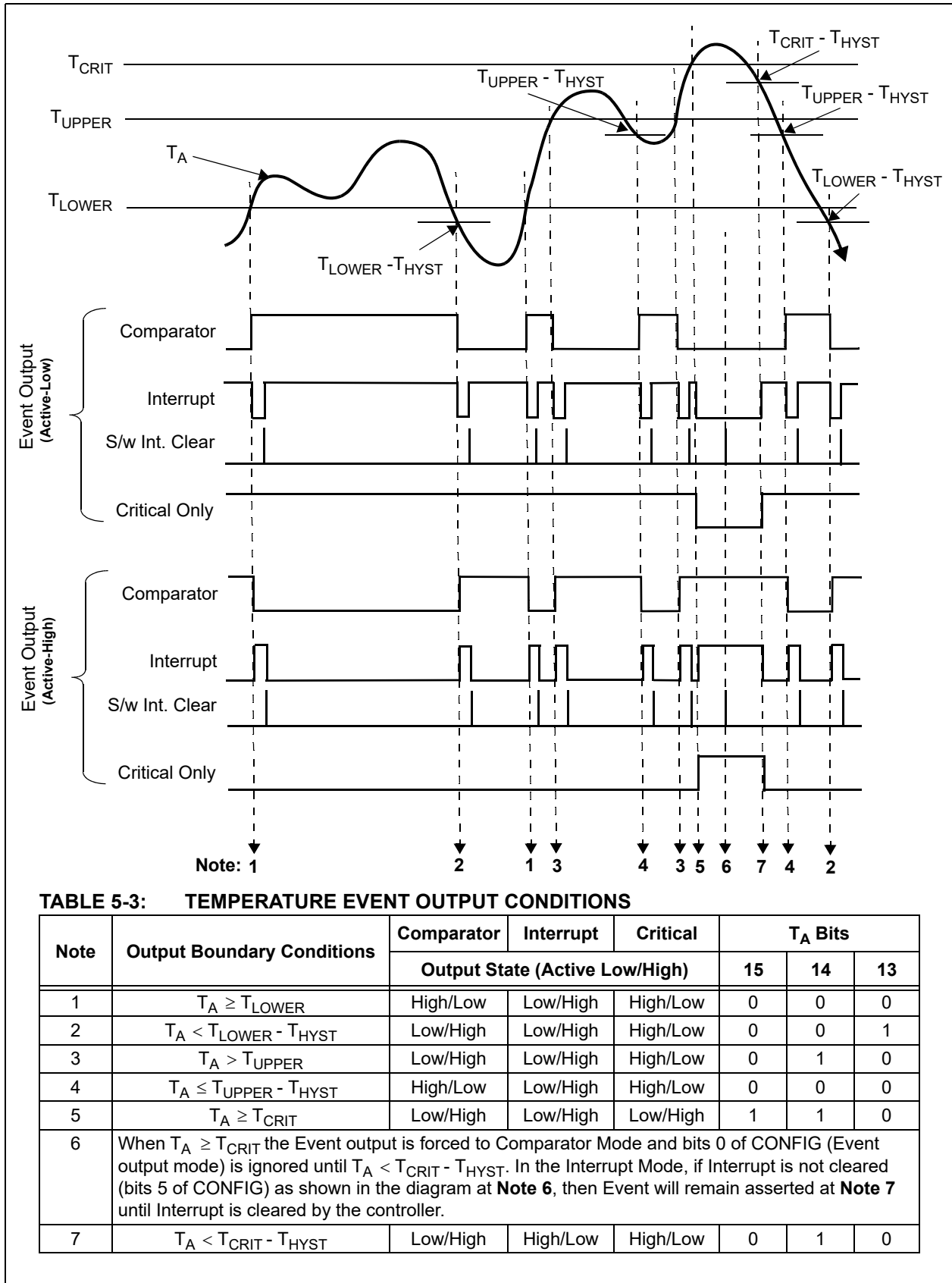

FIGURE 5-9: Event Output Condition.

5.3 MCP98244 EEPROM FEATURE DESCRIPTION

5.3.1 BYTE WRITE

To write a byte in the MCP98244 EEPROM, the host has to specify the memory location or address. Once the address byte is transmitted correctly followed by a word address, the word address is stored in the EEPROM address pointer. The following byte is data to be stored in the specified memory location. [Figure 5-10](#) shows the timing diagram.

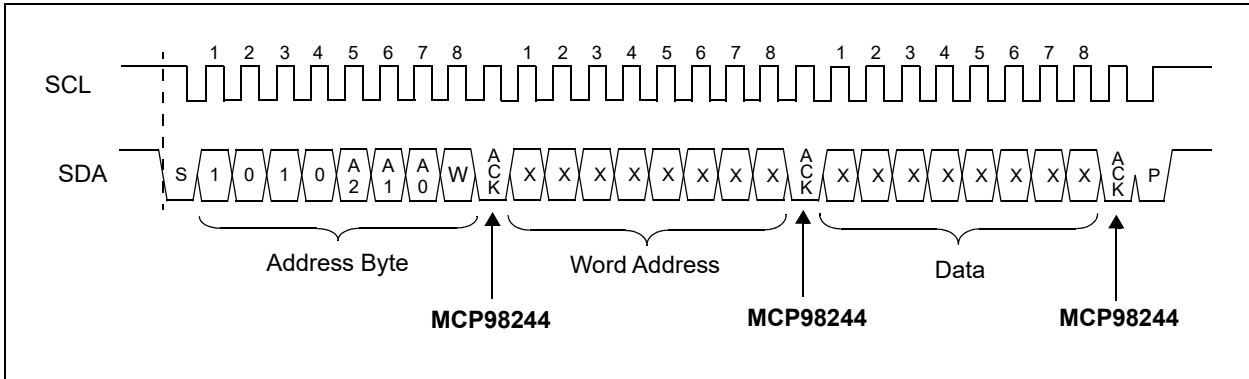

FIGURE 5-10: Timing Diagram for Byte Write (See [Section 4.0 “Serial Communication”](#)).

MCP98244

5.3.2 PAGE WRITE

The write Address Byte, word address and the first data byte are transmitted to the MCP98244 in the same way as in a byte write. Instead of generating a Stop condition, the host transmits up to 15 additional data bytes to the MCP98244, which are temporarily stored in the on-chip page buffer and will be written into the memory after the host has transmitted a Stop condition. Upon receipt of each word, the four lower order address pointer bits are internally incremented by one. The higher order four bits of the word address remain constant. If the host should transmit more than 16 bytes prior to generating the Stop condition, the address counter will roll over and the previously received data will be overwritten. As with the byte write operation, once the Stop condition is received, an internal write cycle will begin (Figure 5-11).

Note: Page write operations are limited to writing bytes within a single physical page, regardless of the number of bytes actually being written. Physical page boundaries start at addresses that are integer multiples of the page buffer size (or 'page size') and end at addresses that are integer multiples of [page size - 1]. If a Page Write command attempts to write across a physical page boundary, the result is that the data wraps around to the beginning of the current page (overwriting data previously stored there), instead of being written to the next page, as might be expected. It is therefore necessary for the application software to prevent page write operations that would attempt to cross a page boundary.

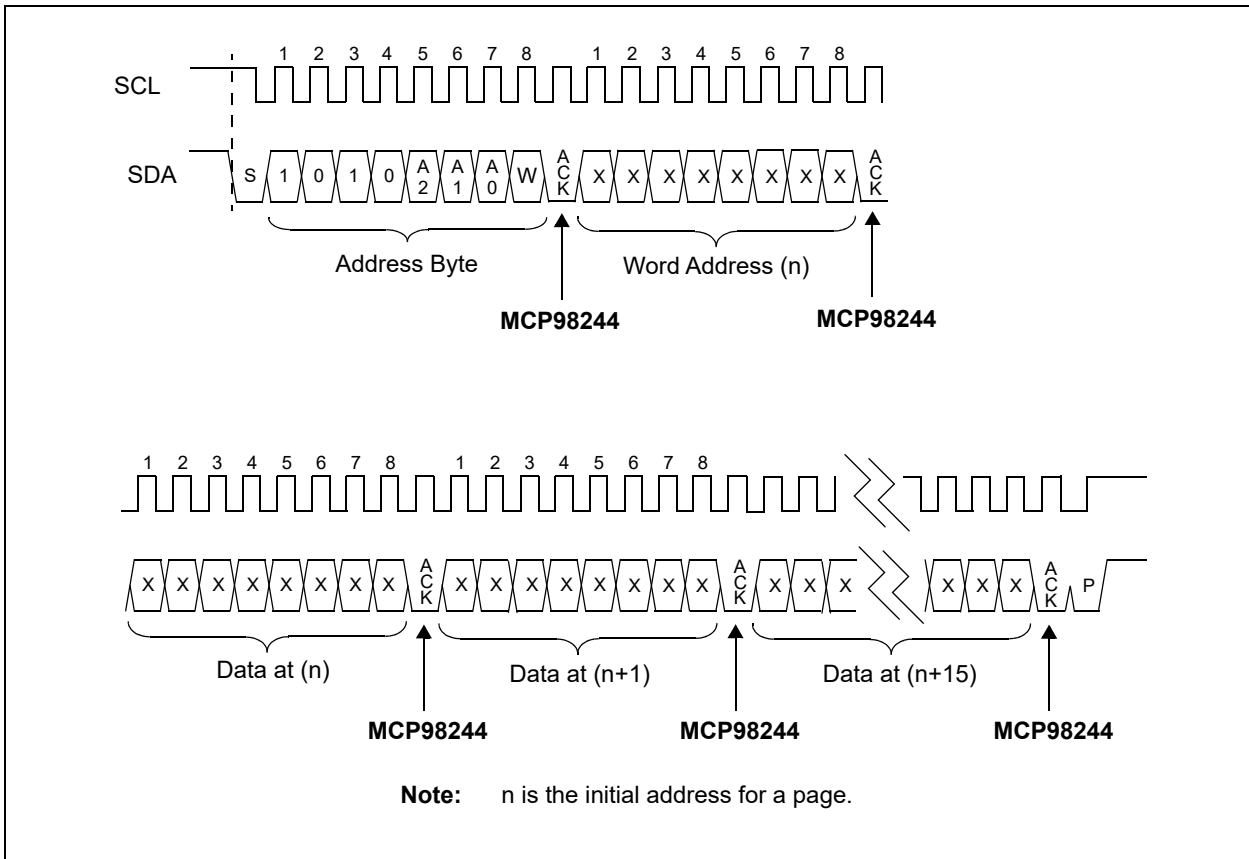

FIGURE 5-11: Timing Diagram for Page Write (See Section 4.0 “Serial Communication”).

5.3.3 BANK OR PAGE SELECTION FOR EEPROM READ/WRITE OPERATION

There are two 256 byte banks or pages in this device (512 bytes total). The pages are selected using I²C Set Page Address (SPA) command byte of '0110 1100' for bank/page 0 and '0110 1110' for bank/page 1, see [Table 5-5](#).

The current page status can be read using the Read Page Address (RPA) Command. If the device ACK or NAK the command, then the current page is 0 or 1, respectively.

TABLE 5-4: SELECTING 256 BYTE BANKS OR PAGES FOR EEPROM READ/WRITE

EEPROM Function	Operation	Address Byte					A0 PIN Voltage	MCP98244 output
		Address Code	Client Address ¹			R/W		
			A2	A1	A0			
Set Bank/Page Address 0 (SPA0)	WRITE	0110	1	1	0	0	V _{DD} , V _{SS} , V _{HV}	ACK, Page 0 Set
Set Bank/Page Address 1 (SPA1)	WRITE	0110	1	1	1	0	V _{DD} , V _{SS} , V _{HV}	ACK, Page 1 Set
Read Bank/Page Address (RPA)	READ	0110	1	1	0	1	V _{DD} , V _{SS} , V _{HV}	ACK for Page 0 NAK for Page 1

Note 1: A0, A1, A2 address pin states are ignored.

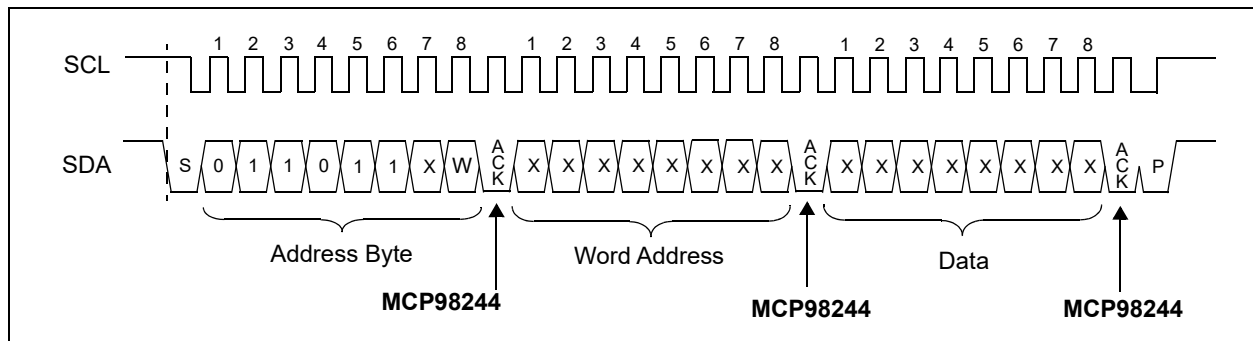

FIGURE 5-12: Timing Diagram for Bank/Page Selection (See [Section 4.0 “Serial Communication”](#)).

MCP98244

5.3.4 WRITE PROTECTION

The MCP98244 has a Software Write-Protect (SWP) feature that allows a 128-byte block to be write-protected. There are four 128-byte blocks. Each block is write protected individually. The write-protected area can be cleared by sending Clear Write Protect (CWP) commands for each block.

To access write protection, the device address code of the Address Byte is set to '0110' instead of '1010'. In this mode, the Client Address pins are ignored. Once the device is write protected it will not acknowledge any write commands to the protected block. [Table 5-5](#) shows the corresponding Address Bytes for the write-protect feature.

5.3.4.1 SWP/RPS

The SWP (Software Write Protect) feature is invoked by writing a command byte as shown on [Table 5-5](#). It can be cleared using the CWP command. In this mode, the Client Address pins are ignored. A high voltage V_{HV} needs to be applied to the A0 pin. RPS (Read Protection Status) can be executed to read protection status.

5.3.4.2 CWP (Clear Write Protect)

The CWP feature is invoked by writing clear write-protect command. A high voltage V_{HV} needs to be applied to the A0 pin and once the command is executed bank/Page 0 and bank/Page 1 are cleared. [Table 5-5](#) shows the bit configuration.

TABLE 5-5: DEVICE CLIENT ADDRESS DURING WRITE PROTECTION (SWP/CWP)

EEPROM Function	Operation	Address Byte ^{2,3}					A0 PIN Voltage
		Address Code ²	Client Address ^{1,2}			$\overline{\text{R/W}}$	
			A2	A1	A0		
SWP ₀ /RPS ₀ — Bank/Page 0, Block 0 00h to 7Fh	SWP ₀ → WRITE	0110	0	0	1	0	V_{HV}
	RPS ₀ → READ ⁴					1	V_{DD}, V_{SS}, V_{HV}
SWP ₁ /RPS ₁ — Bank/Page 0, Block 1 80h to FFh	SWP ₁ → WRITE	0110	1	0	0	0	V_{HV}
	RPS ₁ → READ ⁴					1	V_{DD}, V_{SS}, V_{HV}
SWP ₂ /RPS ₂ — Bank/Page 1, Block 2 00h to 7Fh	SWP ₂ → WRITE	0110	1	0	1	0	V_{HV}
	RPS ₂ → READ ⁴					1	V_{DD}, V_{SS}, V_{HV}
SWP ₃ /RPS ₃ — Bank/Page 1, Block 3 80h to FFh	SWP ₃ → WRITE	0110	0	0	0	0	V_{HV}
	RPS ₃ → READ ⁴					1	V_{DD}, V_{SS}, V_{HV}
CWP (Clear all Pages)	WRITE	0110	0	1	1	0	V_{HV}

Note 1: The client address bits for each block are not binary increments for compatibility.

2: For Address Code <0110> the A0, A1, A2 states are ignored.

3: All address bytes, other than those indicated below, are ignored by the device.

4: The device will NAK if protected and ACK if it is unprotected.

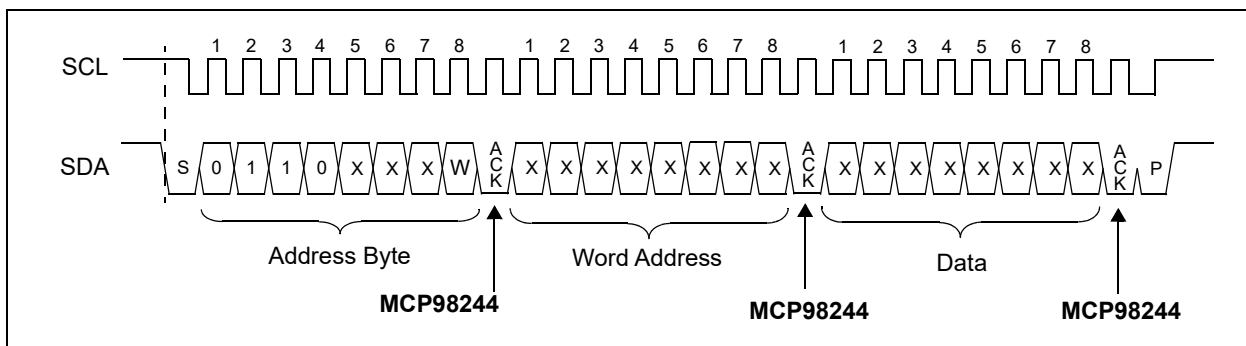

FIGURE 5-13: Timing Diagram for Setting Software Write Protect (See [Section 4.0 “Serial Communication”](#)).

TABLE 5-6: DEVICE RESPONSE WHEN WRITING DATA OR ACCESSING SWP_N/CWP/SPA_N²

Status	Command	ACK	Address	ACK	Data Byte	ACK	STOP Cmd ³	Write/Clear Cycle
Not Protected	SWP _n /CWP	ACK	—	—	—	—	Yes	Yes
	SWP _n /CWP	ACK	0xXX ¹	ACK	—	—	Yes	Yes
	SWP _n /CWP	ACK	0xXX	ACK	0xXX	ACK	Yes	Yes
	Page/byte write	ACK	Address	ACK	Data	ACK	Yes	Yes
Protected	SWP _n	NAK	0xXX	NAK	0xXX	NAK	—	No
	CWP	ACK	—	—	—	—	Yes	Yes
	CWP	ACK	0xXX	ACK	—	—	Yes	Yes
	CWP	ACK	0xXX	ACK	0xXX	ACK	Yes	Yes
	Page/byte write	ACK	Address	ACK	Data	NAK	Yes	No
Protected or Not protected	SPA _{0,1}	ACK	—	—	—	—	Yes/No ⁴	No
	SPA _{0,1}	ACK	0xXX	ACK	—	—		No
	SPA _{0,1}	ACK	0xXX	ACK	0xXX	ACK		No

Note 1: 0xXX is defined as 'don't care' byte.

2: N or n = 1, 2, 3, and 4 which describes the EEPROM Block number as shown in [Table 5-5](#).

3: I²C stop command is necessary to execute the instructions.

4: The device responds SPA_{0,1} Commands with ACK, therefore STOP command is not necessary.

TABLE 5-7: DEVICE RESPONSE WHEN RPA/RPS_N¹¹

Status	Command	ACK	Address	ACK	Data Byte	ACK	STOP Cmd ²
Not Protected	RPS _n	ACK	0xFF	NAK	0xFF	NAK	Yes/No
Protected	RPS _n	NAK	0xFF	NAK	0xFF	NAK	Yes/No
Protected or Not protected	RPA ₀	ACK	0xFF	NAK	0xFF	NAK	Yes/No
	RPA ₁	NAK	0xFF	NAK	0xFF	NAK	Yes/No

Note 1: N or n = 1, 2, 3, and 4 which describes the EEPROM Block number as shown in [Table 5-5](#).

2: Since the responses to these read commands are output on the 9th bit, STOP command is not necessary.

MCP98244

5.3.5 READ OPERATION

Read operations are initiated in the same way as write operations, with the exception that the R/W bit of the client address is set to '1'. There are three basic types of read operations: current address read, random read and sequential read.

5.3.5.1 Current Address Read

The MCP98244 contains an address counter that maintains the address of the last word accessed, internally incremented by '1'. Therefore, if the previous access (either a read or write operation) was to address n , the next current address read operation would access data from address $n+1$. Upon receipt of the client address with R/W bit set to '1', the MCP98244 issues an acknowledge and transmits the 8-bit data word. The host will not acknowledge (NAK) the transfer but does generate a Stop condition and the MCP98244 discontinues transmission (Figure 5-14).

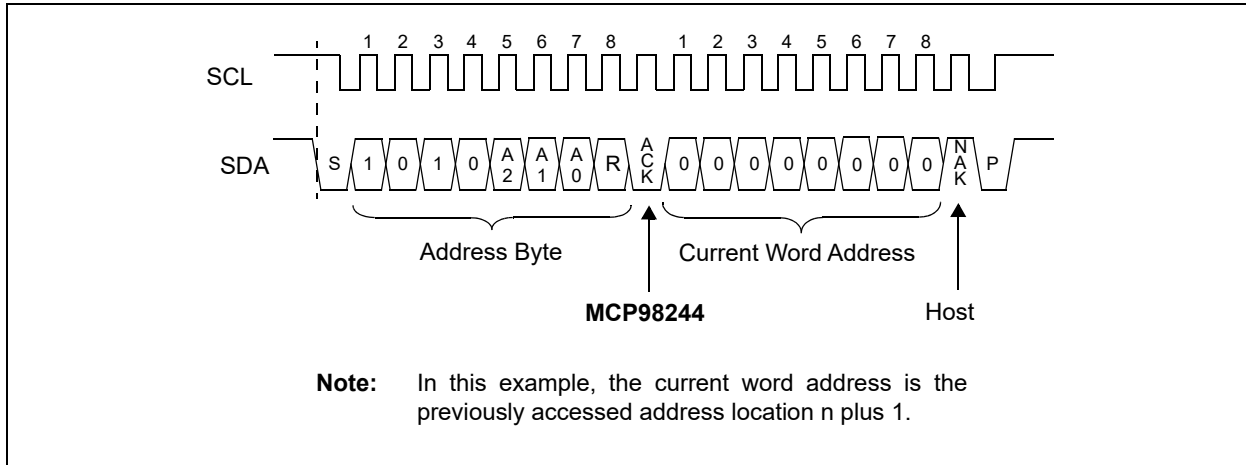

FIGURE 5-14: Reading Current Word Address (See Section 4.0 "Serial Communication").

5.3.5.2 Random Read

Random read operations allow the host to access any memory location in a random manner. To perform this type of read operation, the word address must first be set. This is done by sending the word address to the MCP98244 as part of a write operation. Once the word address is sent, the host generates a start condition following the acknowledge. This terminates the write operation, but not before the internal address pointer is

set. The host then issues the Address Byte again, but with the $\overline{R/\overline{W}}$ bit set to a '1'. The MCP98244 then issues an acknowledge and transmits the 8-bit data word. The host will not acknowledge the transfer but does generate a stop condition and the MCP98244 discontinues transmission (Figure 5-15).

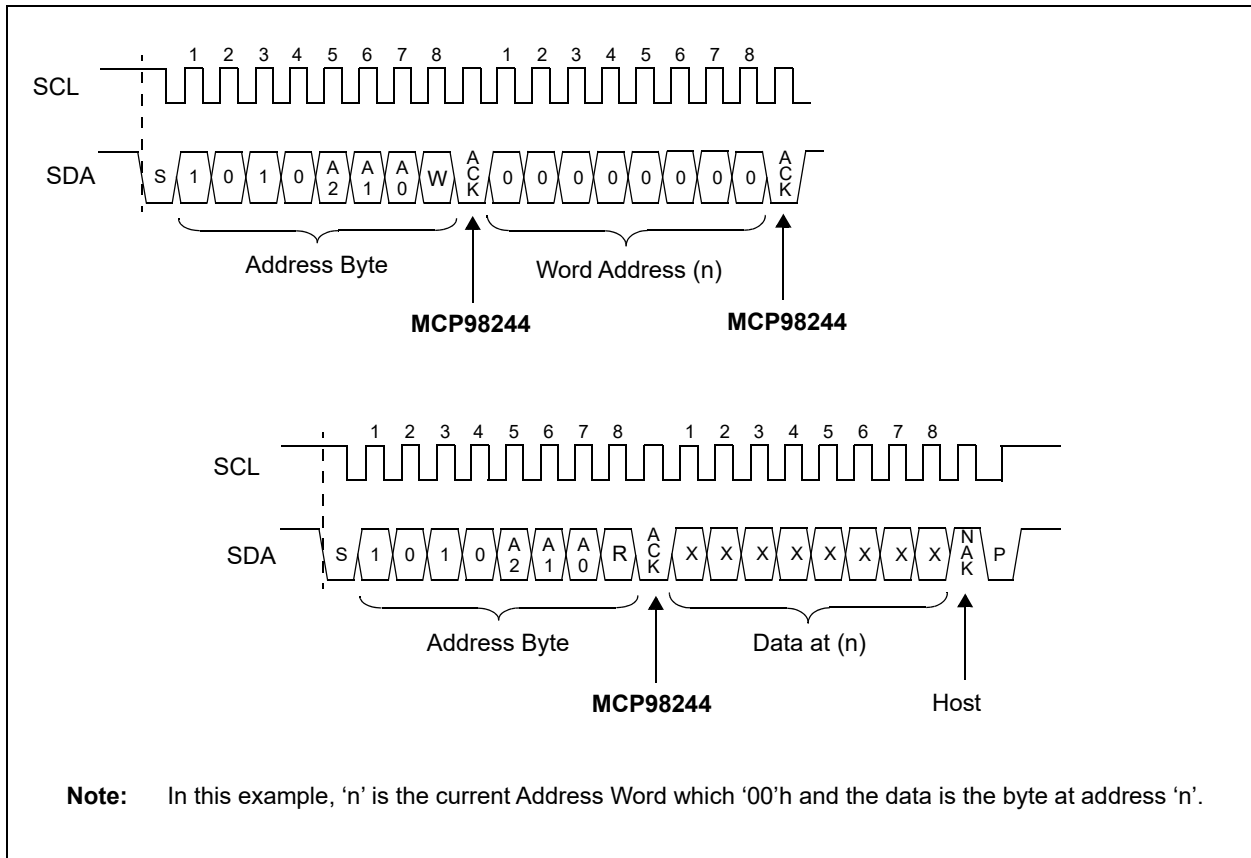

FIGURE 5-15: Timing Diagram for Random Read (See Section 4.0 “Serial Communication”).

MCP98244

5.3.5.3 Sequential Read

Sequential reads are initiated in the same way as a random read, with the exception that after the MCP98244 transmits the first data byte, the host issues an acknowledge, as opposed to a stop condition in a random read. This directs the MCP98244 to transmit the next sequentially addressed 8-bit word (Figure 5-16).

To provide sequential reads, the MCP98244 contains an internal address pointer, which is incremented by one at the completion of each operation. This address pointer allows the entire memory contents to be serially read during one operation.

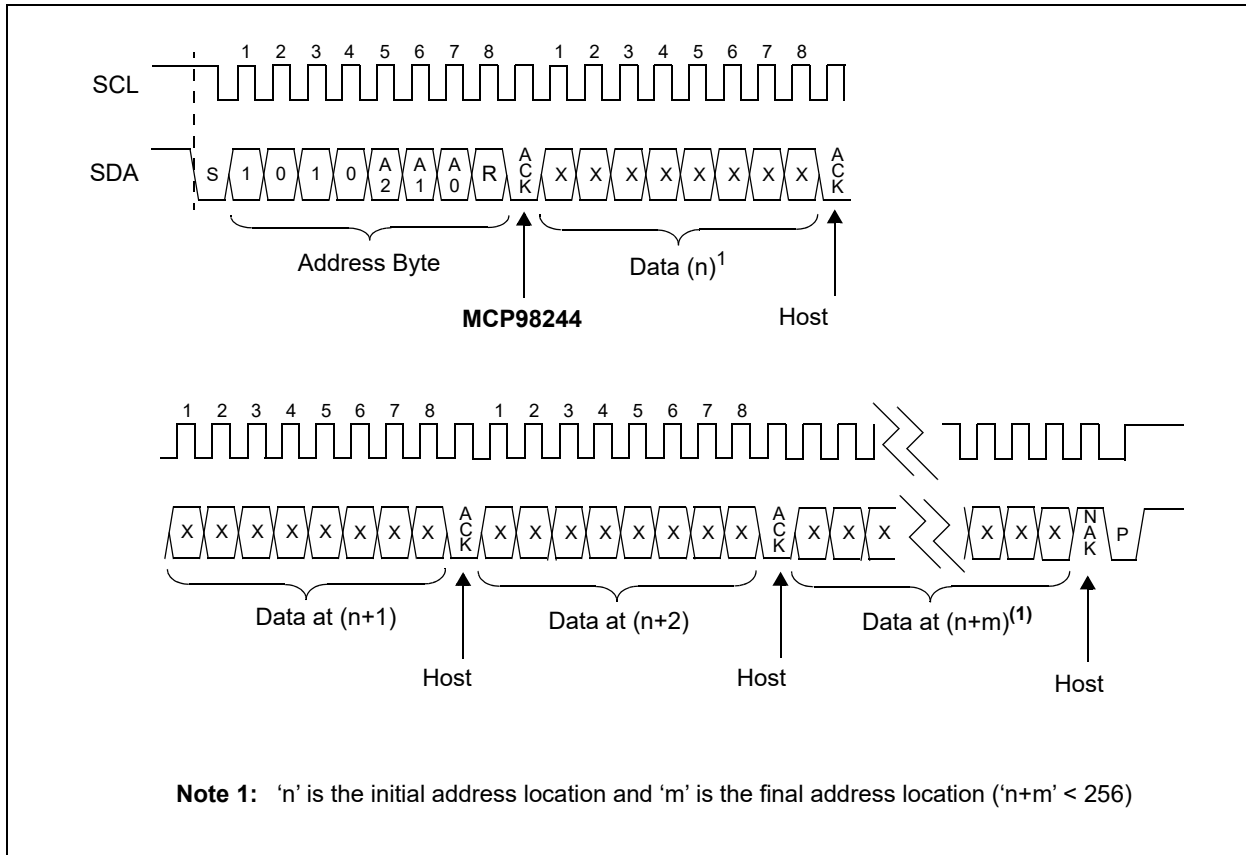

FIGURE 5-16: Timing Diagram for Sequential Read (See Section 4.0 “Serial Communication”).

5.3.6 STANDBY MODE

The design will incorporate a low-power Standby mode (I_{SHDN}). Standby mode will be entered after a normal termination of any operation and after all internal functions are complete. This would include any error conditions occurring, such as improper number of clock cycles or improper instruction byte as defined previously.

5.4 Summary of Power-On Default

The MCP98244 has an internal Power-On Reset (POR) circuit. If the power supply voltage V_{DD} glitches down to the V_{POR_TS} and V_{POR_EE} thresholds, the device resets the registers to the power-on default settings.

Table 5-8 shows the power-on default summary for the temperature sensor. The EEPROM resets the address pointer to 0x00 hex.

TABLE 5-8: MCP98244 TEMPERATURE SENSOR POWER-ON RESET DEFAULTS

Registers		Default Register Data (Hexadecimal)	Power-Up Default Register Description
Address (Hexadecimal)	Register Name		
0x00	Capability	0x00EF	Event output deasserts in Shutdown I ² C time out 25 ms to 35 ms Accepts V_{HV} at A0 pin 0.25°C Measurement Resolution Measures temperature below 0°C ±1°C accuracy over active range Temperature event output
0x01	CONFIG	0x0000	Comparator mode Active-Low output Event and critical output Output disabled Event not asserted Interrupt cleared Event limits unlocked Critical limit unlocked Continuous conversion 0°C Hysteresis
0x02	T _{UPPER}	0x0000	0°C
0x03	T _{LOWER}	0x0000	0°C
0x04	T _{CRIT}	0x0000	0°C
0x05	T _A	0x0000	0°C
0x06	Manufacturer ID	0x0054	—
0x07	TSE2004av Device ID/ Device Revision	0x2201	—
0x08	Microchip Device ID/ Device Revision	0x2201	—
0x09	Resolution	0x0001	0.25°C Measurement Resolution

MCP98244

NOTES:

6.0 APPLICATIONS INFORMATION

6.1 Layout Considerations

The MCP98244 device does not require any additional components besides the host controller in order to measure temperature. However, it is recommended that a decoupling capacitor of 0.1 μF to 1 μF be used between the V_{DD} and GND pins. A high-frequency ceramic capacitor is recommended. It is necessary for the capacitor to be located as close as possible to the power and ground pins of the device in order to provide effective noise protection.

In addition, good PCB layout is key for better thermal conduction from the PCB temperature to the sensor die. For good temperature sensitivity, add a ground layer under the device pins as shown in [Figure 6-1](#).

6.2 Thermal Considerations

A potential for self-heating errors can exist if the MCP98244 SDA, SCLK and Event lines are heavily loaded with pull-ups (high current). Typically, the self-heating error is negligible because of the relatively small current consumption of the MCP98244. A temperature accuracy error of approximately 0.5°C could result from self-heating if the communication pins sink/source the maximum current specified.

For example, if the Event output is loaded to maximum I_{OL} , [Equation 6-1](#) can be used to determine the effect of self-heating.

EQUATION 6-1: EFFECT OF SELF-HEATING

$$T_{\Delta} = \theta_{\text{JA}}(V_{\text{DD}} \cdot I_{\text{DD}} + V_{\text{OL_Event}} \cdot I_{\text{OL_Event}} + V_{\text{OL_SDA}} \cdot I_{\text{OL_SDA}})$$

Where:

$$T_{\Delta} = T_{\text{J}} - T_{\text{A}}$$

T_{J} = Junction Temperature

T_{A} = Ambient Temperature

θ_{JA} = Package Thermal Resistance

$V_{\text{OL_Event, SDA}}$ = Event and SDA Output V_{OL}
(0.4 V_{max})

$I_{\text{OL_Event, SDA}}$ = Event and SDA Output I_{OL}
(3 mA_{max} and 20 mA_{max} ,
respectively)

At room temperature ($T_{\text{A}} = +25^{\circ}\text{C}$) with maximum $I_{\text{DD}} = 500 \mu\text{A}$ and $V_{\text{DD}} = 3.6\text{V}$, the self-heating due to power dissipation T_{Δ} is 0.58°C for the TDFN-8 package.

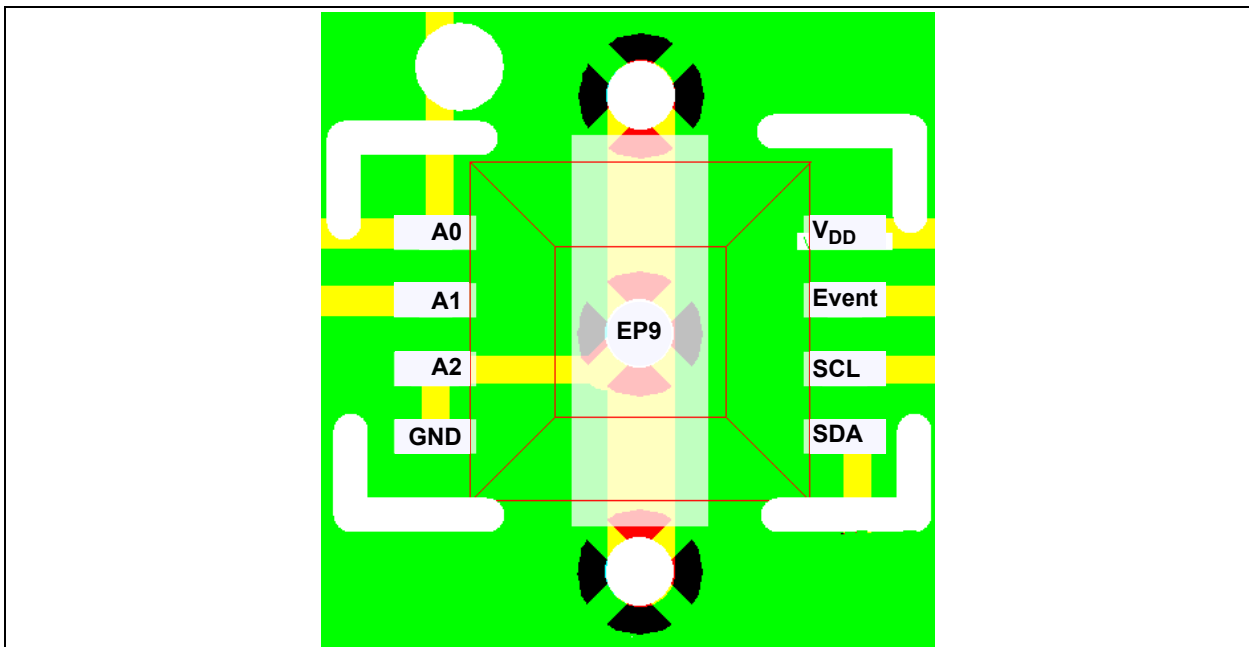

FIGURE 6-1: DFN Package Layout.

MCP98244

NOTES:

7.0 PACKAGING INFORMATION

7.1 Package Marking Information

8-Lead 2x3 TDFN



Part Number	Code
MCP98244T-BE/MNY	ABR

Example:

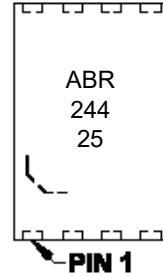

Legend:	XX...X	Customer-specific information
	Y	Year code (last digit of calendar year)
	YY	Year code (last 2 digits of calendar year)
	WW	Week code (week of January 1 is week '01')
	NNN	Alphanumeric traceability code
	(e3)	Pb-free JEDEC designator for Matte Tin (Sn)
	*	This package is Pb-free. The Pb-free JEDEC designator (e3) can be found on the outer packaging for this package.
Note:	In the event the full Microchip part number cannot be marked on one line, it will be carried over to the next line, thus limiting the number of available characters for customer-specific information.	

MCP98244

8-Lead Plastic Dual Flat, No Lead Package (MN) – 2x3x0.8 mm Body [TDFN] With 1.4x1.3 mm Exposed Pad (JEDEC Package type WDFN)

Note: For the most current package drawings, please see the Microchip Packaging Specification located at <http://www.microchip.com/packaging>

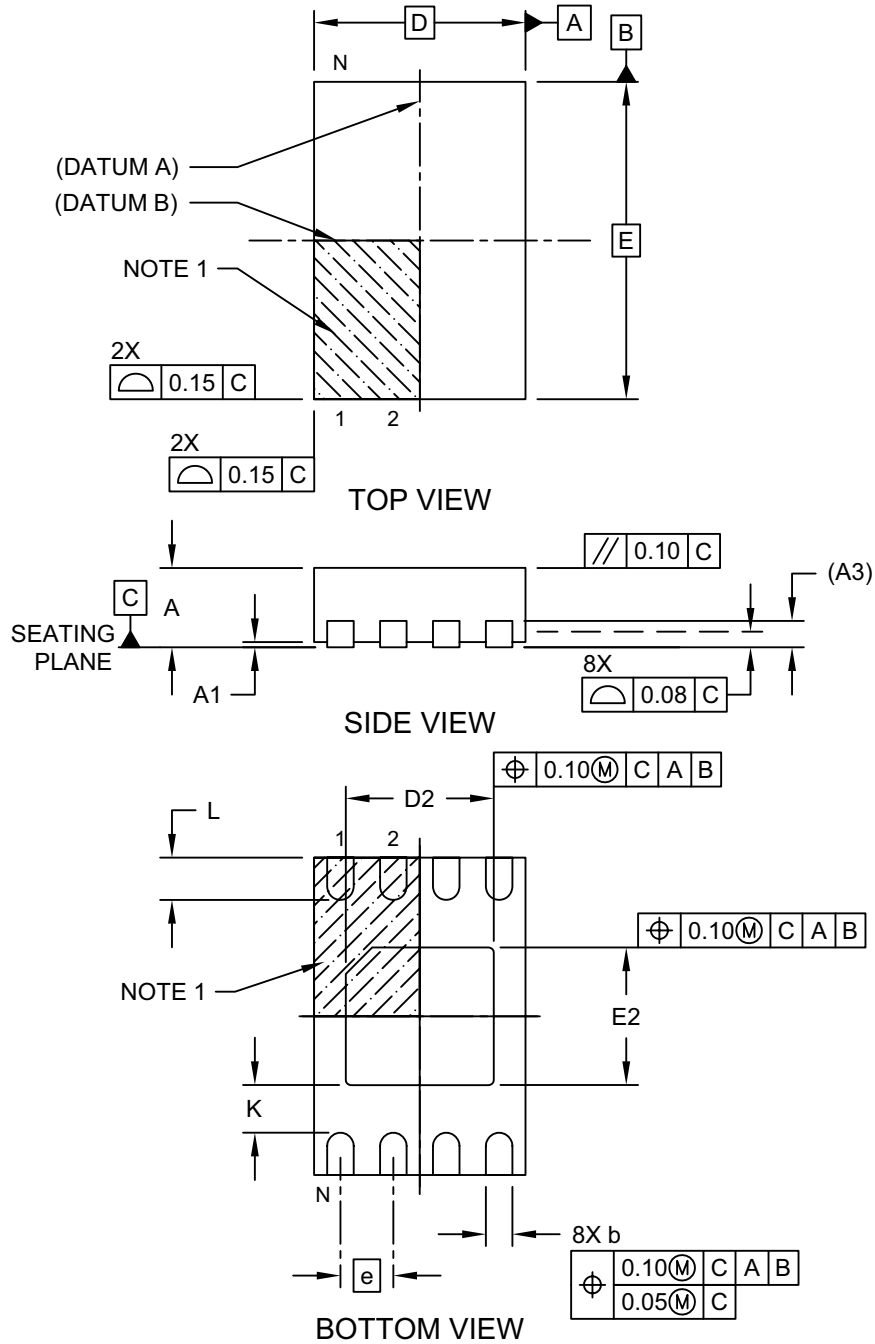

Microchip Technology Drawing No. C04-129-MN Rev E Sheet 1 of 2

8-Lead Plastic Dual Flat, No Lead Package (MN) – 2x3x0.8 mm Body [TDFN] With 1.4x1.3 mm Exposed Pad (JEDEC Package type WDFN)

Note: For the most current package drawings, please see the Microchip Packaging Specification located at <http://www.microchip.com/packaging>

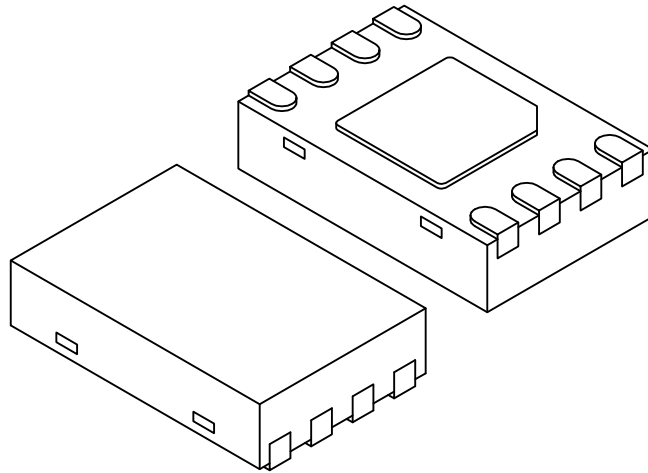

Dimension Limits	Units	MILLIMETERS		
		MIN	NOM	MAX
Number of Pins	N	8		
Pitch	e	0.50 BSC		
Overall Height	A	0.70	0.75	0.80
Standoff	A1	0.00	0.02	0.05
Contact Thickness	A3	0.20 REF		
Overall Length	D	2.00 BSC		
Overall Width	E	3.00 BSC		
Exposed Pad Length	D2	1.35	1.40	1.45
Exposed Pad Width	E2	1.25	1.30	1.35
Contact Width	b	0.20	0.25	0.30
Contact Length	L	0.25	0.30	0.45
Contact-to-Exposed Pad	K	0.20	-	-

Notes:

1. Pin 1 visual index feature may vary, but must be located within the hatched area.
2. Package may have one or more exposed tie bars at ends.
3. Package is saw singulated
4. Dimensioning and tolerancing per ASME Y14.5M

BSC: Basic Dimension. Theoretically exact value shown without tolerances.

REF: Reference Dimension, usually without tolerance, for information purposes only.

Microchip Technology Drawing No. C04-129-MN Rev E Sheet 2 of 2

MCP98244

8-Lead Plastic Dual Flat, No Lead Package (MN) – 2x3x0.8 mm Body [TDFN] With 1.4x1.3 mm Exposed Pad (JEDEC Package type WDFN)

Note: For the most current package drawings, please see the Microchip Packaging Specification located at <http://www.microchip.com/packaging>

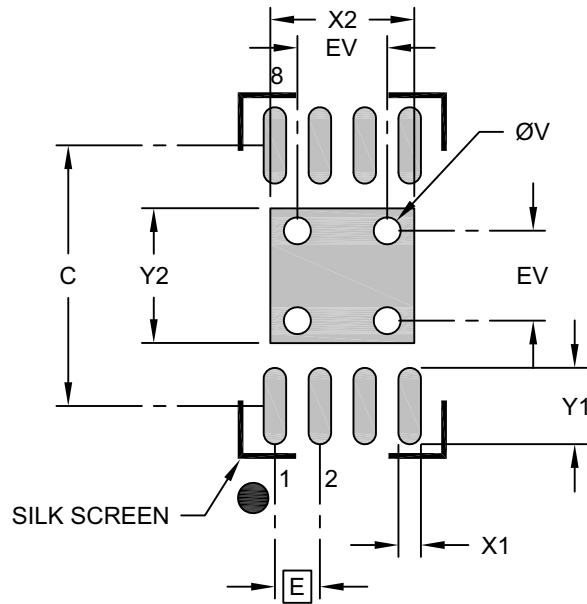

RECOMMENDED LAND PATTERN

Dimension Limits	Units	MILLIMETERS		
		MIN	NOM	MAX
Contact Pitch	E	0.50 BSC		
Optional Center Pad Width	X2			1.60
Optional Center Pad Length	Y2			1.50
Contact Pad Spacing	C		2.90	
Contact Pad Width (X8)	X1			0.25
Contact Pad Length (X8)	Y1			0.85
Thermal Via Diameter	V		0.30	
Thermal Via Pitch	EV		1.00	

Notes:

1. Dimensioning and tolerancing per ASME Y14.5M
BSC: Basic Dimension. Theoretically exact value shown without tolerances.
2. For best soldering results, thermal vias, if used, should be filled or tented to avoid solder loss during reflow process

Microchip Technology Drawing No. C04-129-MN Rev. B

APPENDIX A: REVISION HISTORY

Revision D (March 2022)

The following is the list of modification:

- Updated the [MCP98244 EEPROM DC Characteristics](#) table.
- Updated the title of [Figure 2-3](#).
- Updated the description of bit 2 in [Register 5-3](#).
- Updated [Section 5.2.3 “Event Output Configuration”](#).
- Updated [Section 7.0 “Packaging Information”](#).
- Updated “Master/Slave” terminology throughout the document to “Host/Client”.
- Minor editorial corrections.

Revision C (May 2013)

The following is the list of modifications:

- Updated the operating voltage range from $V_{DD} = 2.2V$ to $3.6V$ to $V_{DD} = 1.7V$ to $3.6V$.
- Updated the verbiage throughout the document relevant to the change in V_{DD} range.
- Updated [Figure 2-1](#) and [Figure 2-4](#).
- Incremented the silicon revision ID from 0x00 to 0x01.

Revision B (December 2012)

The following is the list of modification:

- Updated the temperature range in the [Serial Interface Timing Specifications](#) table.

Revision A (December 2012)

- Original Release of this Document.

MCP98244

NOTES:

PRODUCT IDENTIFICATION SYSTEM

To order or obtain information, e.g., on pricing or delivery, refer to the factory or the listed sales office.

<u>PART NO.</u>	<u>-X</u>	<u>X</u>	<u>/XX</u>
Device	Grade	Temperature Range	Package
Device:	MCP98244T:	Temperature Sensor (Tape and Reel)	
Temperature Range:	E	= -40°C to +125°C (Extended)	
Package:	MNY	= Plastic Dual Flat, No Lead, (2x3 TDFN), 8-lead (TDFN)	

Examples:

a) MCP98244T-BE/MNY: Tape and Reel, Extended Temp., 8LD 2x3 TDFN package

MCP98244

NOTES:

Note the following details of the code protection feature on Microchip products:

- Microchip products meet the specifications contained in their particular Microchip Data Sheet.
- Microchip believes that its family of products is secure when used in the intended manner, within operating specifications, and under normal conditions.
- Microchip values and aggressively protects its intellectual property rights. Attempts to breach the code protection features of Microchip product is strictly prohibited and may violate the Digital Millennium Copyright Act.
- Neither Microchip nor any other semiconductor manufacturer can guarantee the security of its code. Code protection does not mean that we are guaranteeing the product is “unbreakable”. Code protection is constantly evolving. Microchip is committed to continuously improving the code protection features of our products.

This publication and the information herein may be used only with Microchip products, including to design, test, and integrate Microchip products with your application. Use of this information in any other manner violates these terms. Information regarding device applications is provided only for your convenience and may be superseded by updates. It is your responsibility to ensure that your application meets with your specifications. Contact your local Microchip sales office for additional support or, obtain additional support at <https://www.microchip.com/en-us/support/design-help/client-support-services>.

THIS INFORMATION IS PROVIDED BY MICROCHIP "AS IS". MICROCHIP MAKES NO REPRESENTATIONS OR WARRANTIES OF ANY KIND WHETHER EXPRESS OR IMPLIED, WRITTEN OR ORAL, STATUTORY OR OTHERWISE, RELATED TO THE INFORMATION INCLUDING BUT NOT LIMITED TO ANY IMPLIED WARRANTIES OF NON-INFRINGEMENT, MERCHANTABILITY, AND FITNESS FOR A PARTICULAR PURPOSE, OR WARRANTIES RELATED TO ITS CONDITION, QUALITY, OR PERFORMANCE.

IN NO EVENT WILL MICROCHIP BE LIABLE FOR ANY INDIRECT, SPECIAL, PUNITIVE, INCIDENTAL, OR CONSEQUENTIAL LOSS, DAMAGE, COST, OR EXPENSE OF ANY KIND WHATSOEVER RELATED TO THE INFORMATION OR ITS USE, HOWEVER CAUSED, EVEN IF MICROCHIP HAS BEEN ADVISED OF THE POSSIBILITY OR THE DAMAGES ARE FORESEEABLE. TO THE FULLEST EXTENT ALLOWED BY LAW, MICROCHIP'S TOTAL LIABILITY ON ALL CLAIMS IN ANY WAY RELATED TO THE INFORMATION OR ITS USE WILL NOT EXCEED THE AMOUNT OF FEES, IF ANY, THAT YOU HAVE PAID DIRECTLY TO MICROCHIP FOR THE INFORMATION.

Use of Microchip devices in life support and/or safety applications is entirely at the buyer's risk, and the buyer agrees to defend, indemnify and hold harmless Microchip from any and all damages, claims, suits, or expenses resulting from such use. No licenses are conveyed, implicitly or otherwise, under any Microchip intellectual property rights unless otherwise stated.

For information regarding Microchip's Quality Management Systems, please visit www.microchip.com/quality.

Trademarks

The Microchip name and logo, the Microchip logo, Adaptec, AnyRate, AVR, AVR logo, AVR Freaks, BesTime, BitCloud, CryptoMemory, CryptoRF, dsPIC, flexPWR, HELDO, IGLOO, JukeBlox, KeeLoq, Kleer, LANCheck, LinkMD, maXStylus, maXTouch, MediaLB, megaAVR, Microsemi, Microsemi logo, MOST, MOST logo, MPLAB, OptoLyzer, PIC, picoPower, PICSTART, PIC32 logo, PolarFire, Prochip Designer, QTouch, SAM-BA, SenGenuity, SpyNIC, SST, SST Logo, SuperFlash, Symmetricom, SyncServer, Tachyon, TimeSource, tinyAVR, UNI/O, Vectron, and XMEGA are registered trademarks of Microchip Technology Incorporated in the U.S.A. and other countries.

AgileSwitch, APT, ClockWorks, The Embedded Control Solutions Company, EtherSynch, Flashtec, Hyper Speed Control, HyperLight Load, IntelliMOS, Libero, motorBench, mTouch, Powermite 3, Precision Edge, ProASIC, ProASIC Plus, ProASIC Plus logo, QuietWire, SmartFusion, SyncWorld, Temux, TimeCesium, TimeHub, TimePictra, TimeProvider, TrueTime, WinPath, and ZL are registered trademarks of Microchip Technology Incorporated in the U.S.A.

Adjacent Key Suppression, AKS, Analog-for-the-Digital Age, Any Capacitor, AnyIn, AnyOut, Augmented Switching, BlueSky, BodyCom, CodeGuard, CryptoAuthentication, CryptoAutomotive, CryptoCompanion, CryptoController, dsPICDEM, dsPICDEM.net, Dynamic Average Matching, DAM, ECAN, Espresso T1S, EtherGREEN, GridTime, IdealBridge, In-Circuit Serial Programming, ICSP, INICnet, Intelligent Paralleling, Inter-Chip Connectivity, JitterBlocker, Knob-on-Display, maxCrypto, maxView, memBrain, Mindi, MiWi, MPASM, MPF, MPLAB Certified logo, MPLIB, MPLINK, MultiTRAK, NetDetach, NVM Express, NVMe, Omniscient Code Generation, PICDEM, PICDEM.net, PICKit, PICtail, PowerSmart, PureSilicon, QMatrix, REAL ICE, Ripple Blocker, RTAX, RTG4, SAM-ICE, Serial Quad I/O, simpleMAP, SimpliPHY, SmartBuffer, SmartHLS, SMART-I.S., storClad, SQL, SuperSwitcher, SuperSwitcher II, Switchtec, SynchroPHY, Total Endurance, TSHARC, USBCheck, VariSense, VectorBlox, VeriPHY, ViewSpan, WiperLock, XpressConnect, and ZENA are trademarks of Microchip Technology Incorporated in the U.S.A. and other countries.

SQTP is a service mark of Microchip Technology Incorporated in the U.S.A.

The Adaptec logo, Frequency on Demand, Silicon Storage Technology, Symmcom, and Trusted Time are registered trademarks of Microchip Technology Inc. in other countries.

GestIC is a registered trademark of Microchip Technology Germany II GmbH & Co. KG, a subsidiary of Microchip Technology Inc., in other countries.

All other trademarks mentioned herein are property of their respective companies.

© 2012-2022, Microchip Technology Incorporated and its subsidiaries.

All Rights Reserved.

ISBN: 978-1-5224-9991-6



MICROCHIP

Worldwide Sales and Service

AMERICAS

Corporate Office
2355 West Chandler Blvd.
Chandler, AZ 85224-6199
Tel: 480-792-7200
Fax: 480-792-7277
Technical Support:
<http://www.microchip.com/support>
Web Address:
www.microchip.com

Atlanta

Duluth, GA
Tel: 678-957-9614
Fax: 678-957-1455

Austin, TX

Tel: 512-257-3370

Boston

Westborough, MA
Tel: 774-760-0087
Fax: 774-760-0088

Chicago

Itasca, IL
Tel: 630-285-0071
Fax: 630-285-0075

Dallas

Addison, TX
Tel: 972-818-7423
Fax: 972-818-2924

Detroit

Novi, MI
Tel: 248-848-4000

Houston, TX

Tel: 281-894-5983

Indianapolis

Noblesville, IN
Tel: 317-773-8323
Fax: 317-773-5453
Tel: 317-536-2380

Los Angeles

Mission Viejo, CA
Tel: 949-462-9523
Fax: 949-462-9608
Tel: 951-273-7800

Raleigh, NC

Tel: 919-844-7510

New York, NY

Tel: 631-435-6000

San Jose, CA

Tel: 408-735-9110
Tel: 408-436-4270

Canada - Toronto

Tel: 905-695-1980
Fax: 905-695-2078

ASIA/PACIFIC

Australia - Sydney
Tel: 61-2-9868-6733

China - Beijing
Tel: 86-10-8569-7000

China - Chengdu
Tel: 86-28-8665-5511

China - Chongqing
Tel: 86-23-8980-9588

China - Dongguan
Tel: 86-769-8702-9880

China - Guangzhou
Tel: 86-20-8755-8029

China - Hangzhou
Tel: 86-571-8792-8115

China - Hong Kong SAR
Tel: 852-2943-5100

China - Nanjing
Tel: 86-25-8473-2460

China - Qingdao
Tel: 86-532-8502-7355

China - Shanghai
Tel: 86-21-3326-8000

China - Shenyang
Tel: 86-24-2334-2829

China - Shenzhen
Tel: 86-755-8864-2200

China - Suzhou
Tel: 86-186-6233-1526

China - Wuhan
Tel: 86-27-5980-5300

China - Xian
Tel: 86-29-8833-7252

China - Xiamen
Tel: 86-592-2388138

China - Zhuhai
Tel: 86-756-3210040

ASIA/PACIFIC

India - Bangalore
Tel: 91-80-3090-4444

India - New Delhi
Tel: 91-11-4160-8631

India - Pune
Tel: 91-20-4121-0141

Japan - Osaka
Tel: 81-6-6152-7160

Japan - Tokyo
Tel: 81-3-6880-3770

Korea - Daegu
Tel: 82-53-744-4301

Korea - Seoul
Tel: 82-2-554-7200

Malaysia - Kuala Lumpur
Tel: 60-3-7651-7906

Malaysia - Penang
Tel: 60-4-227-8870

Philippines - Manila
Tel: 63-2-634-9065

Singapore
Tel: 65-6334-8870

Taiwan - Hsin Chu
Tel: 886-3-577-8366

Taiwan - Kaohsiung
Tel: 886-7-213-7830

Taiwan - Taipei
Tel: 886-2-2508-8600

Thailand - Bangkok
Tel: 66-2-694-1351

Vietnam - Ho Chi Minh
Tel: 84-28-5448-2100

EUROPE

Austria - Wels
Tel: 43-7242-2244-39
Fax: 43-7242-2244-393

Denmark - Copenhagen
Tel: 45-4485-5910
Fax: 45-4485-2829

Finland - Espoo
Tel: 358-9-4520-820

France - Paris
Tel: 33-1-69-53-63-20
Fax: 33-1-69-30-90-79

Germany - Garching
Tel: 49-8931-9700

Germany - Haan
Tel: 49-2129-3766400

Germany - Heilbronn
Tel: 49-7131-72400

Germany - Karlsruhe
Tel: 49-721-625370

Germany - Munich
Tel: 49-89-627-144-0
Fax: 49-89-627-144-44

Germany - Rosenheim
Tel: 49-8031-354-560

Israel - Ra'anana
Tel: 972-9-744-7705

Italy - Milan
Tel: 39-0331-742611
Fax: 39-0331-466781

Italy - Padova
Tel: 39-049-7625286

Netherlands - Drunen
Tel: 31-416-690399
Fax: 31-416-690340

Norway - Trondheim
Tel: 47-7288-4388

Poland - Warsaw
Tel: 48-22-3325737

Romania - Bucharest
Tel: 40-21-407-87-50

Spain - Madrid
Tel: 34-91-708-08-90
Fax: 34-91-708-08-91

Sweden - Gothenberg
Tel: 46-31-704-60-40

Sweden - Stockholm
Tel: 46-8-5090-4654

UK - Wokingham
Tel: 44-118-921-5800
Fax: 44-118-921-5820