

Thermocouple EMF to Temperature Converter, ±1.5°C Maximum Accuracy

Features

- Thermocouple Electromotive Force (EMF) to °C Converter:
 - Integrated cold-junction compensation
 - Integrated thermocouple open-circuit and short-circuit detection (MCP9601/L01/RL01)
- Supported Types (designated by NIST ITS-90):
 - Type K, J, T, N, S, E, B and R
- Sensor Accuracy for Thermocouple Hot-Junction:
 - MCP9600/01 ±0.5°C/±1.5°C (typ./max.)
 - MCP96L00/L01 ±2.0°C/±4.0°C (typ./max.)
 - MCP96RL00/RL01 ±4.0°C/±8.0°C (typ./max.)
- Measurement Resolution:
 - Hot and cold-junctions: +0.0625°C (typical)
- Four Programmable Temperature Alert Outputs:
 - Monitor hot or cold-junction temperatures
 - Detect rising or falling temperatures
 - Up to 255°C of programmable hysteresis
- Programmable Digital Filter for Temperature
- Low Power:
 - Shutdown mode
 - Burst mode: 1 to 128 temperature samples
- Two-Wire Interface: I²C Compatible, 100 kHz:
 - Supports eight devices per I²C Bus
- Operating Voltage Range: 2.7V to 5.5V
- Operating Current: 300 µA (typical)
- Shutdown Current: 2 µA (typical)
- Package: 20-Lead MQFN

Typical Applications

- Petrochemical Thermal Management
- Hand-Held Measurement Equipment
- Industrial Equipment Thermal Management
- Commercial and Industrial Ovens
- Industrial Engine Thermal Monitor
- Temperature Detection Racks

Description

The Microchip Technology Inc. MCP960X/L0X/RL0X converts thermocouple EMF to degree Celsius with integrated cold-junction compensation. The temperature correction coefficients are derived from the National Institute of Standards and Technology (NIST) ITS-90 Thermocouple Database. The MCP9600/01 corrects the thermocouple nonlinear error characteristics of eight thermocouple types and outputs ±0.5°C/±1.5°C (Typ./Max.).

The MCP960X/L0X/RL0X digital Thermocouple temperature converter comes with user-programmable registers which provide design flexibility for various temperature sensing applications. The registers allow user-selectable settings, such as Low-Power modes for battery powered applications, adjustable digital filter for fast transient temperatures and four individually programmable temperature alert outputs which can be used to detect multiple temperature zones.

In addition, the MCP9601/L01/RL01 family provides integrated thermocouple open-circuit and short-circuit detection features. An alert signal is asserted when the thermocouple wire is broken or disconnected. Similarly, alert signal is asserted when the thermocouple is shorted to ground or power.

The temperature alert limits have multiple user-programmable configurations, such as alert polarity as either an active-low or active-high push-pull output, and output function as a Comparator mode (useful for thermostat-type operation) or Interrupt mode for microprocessor-based systems. In addition, the alerts can detect either a rising or a falling temperature with up to +255°C hysteresis.

This sensor uses an industry standard two-wire, I²C compatible serial interface and supports up to eight devices per bus by setting the device address using the ADDR pin.

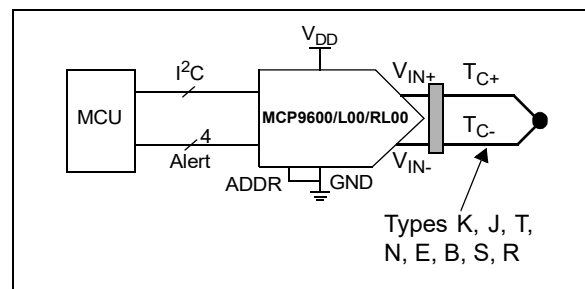

MCP960X/L0X/RL0X

Package Types

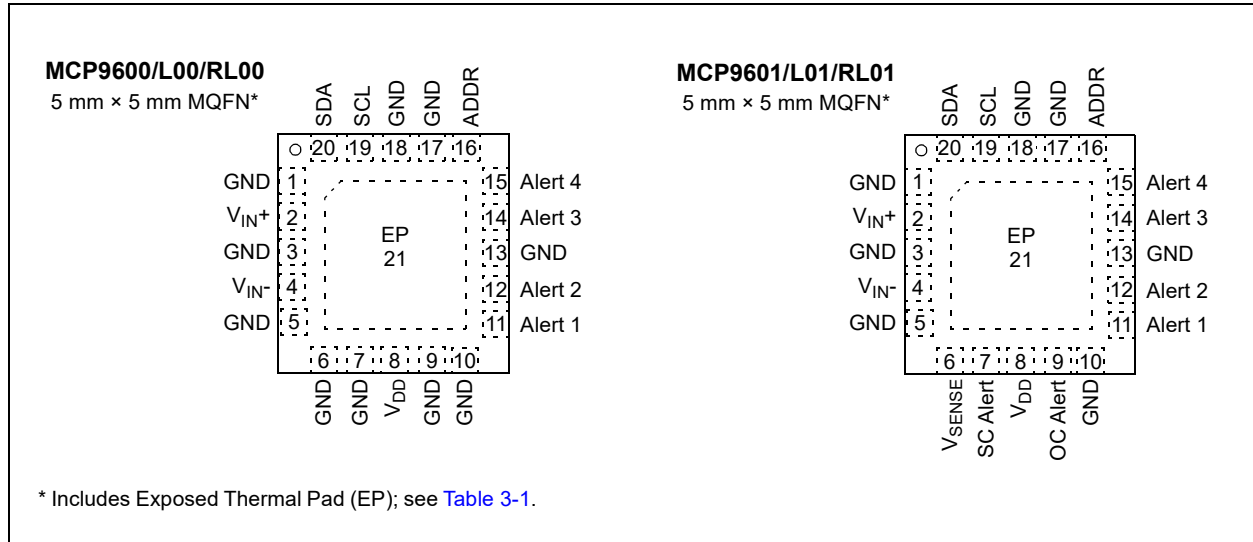

MCP960X/L0X/RL0X Block Diagram

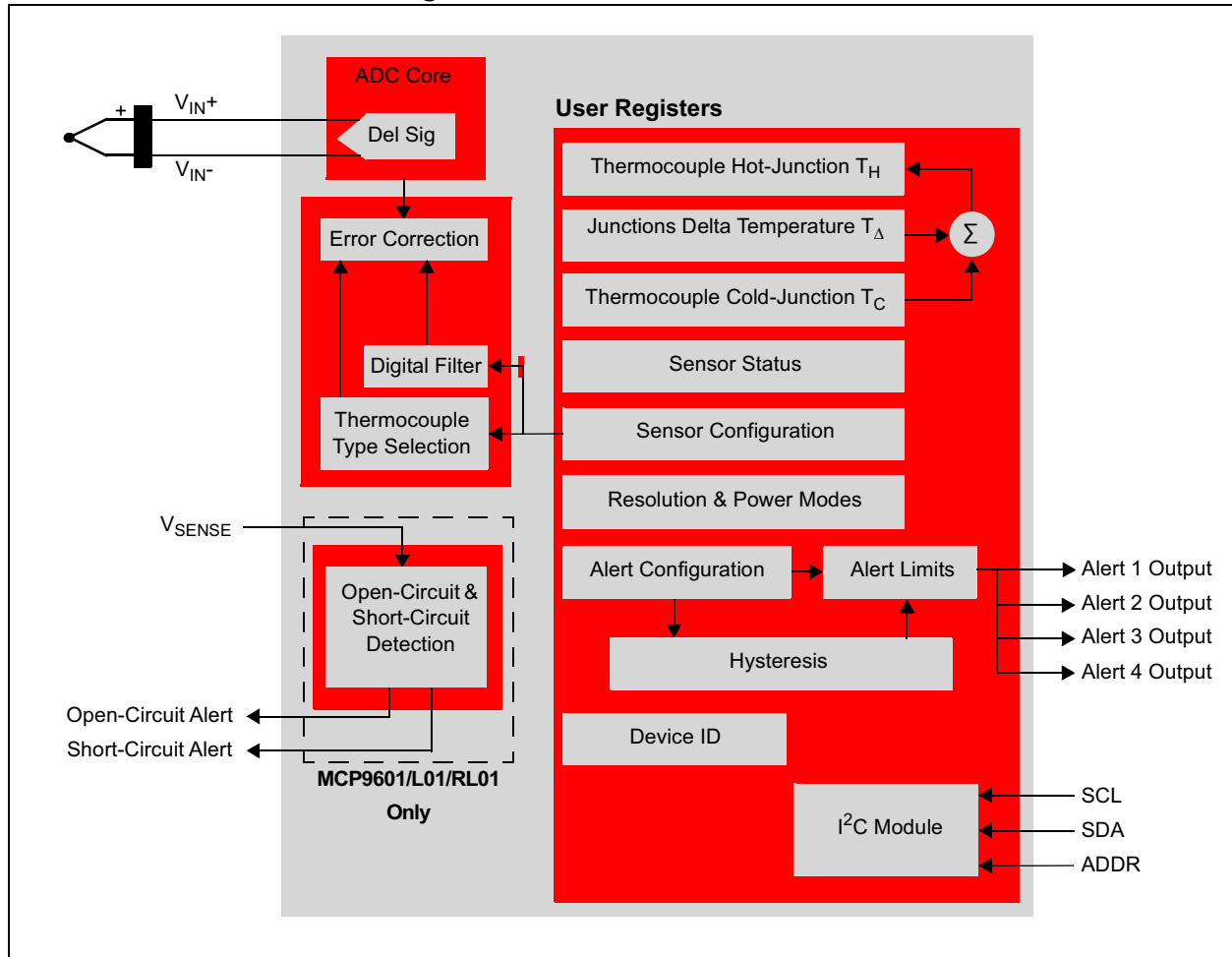

1.0 ELECTRICAL CHARACTERISTICS

Absolute Maximum Ratings †

V _{DD}	6.0V
Voltage at All Input/Output Pins	GND – 0.3V to 6.0V
Storage Temperature	-65°C to +150°C
Ambient Temperature with Power Applied	-40°C to +125°C
Junction Temperature (T _J).....	+150°C
ESD Protection on All Pins (HBM:MM)	(4 kV:300V)
Latch-up Current at Each Pin.....	±100 mA

† **Notice:** Stresses above those listed under “Maximum ratings” may cause permanent damage to the device. This is a stress rating only and functional operation of the device at those or any other conditions above those indicated in the operational listings of this specification is not implied. Exposure to maximum rating conditions for extended periods may affect device reliability.

DC CHARACTERISTICS

Electrical Specifications: Unless otherwise indicated, V_{DD} = 2.7V to 5.5V, GND = Ground, T_A = -40°C to +125°C (where: T_A = T_C, defined as Device Ambient Temperature).

Parameters	Sym.	Min.	Typ.	Max.	Unit	Conditions
Thermocouple Sensor Measurement Accuracy – MCP9600/01						
T _H Hot-Junction Accuracy (V _{DD} = 3.3V) T _H = T _C + T _Δ (Note 1)	T _{H_ACY}	-1.5 -3.0	±0.5 ±1	+1.5 +3.0	°C	T _A = 0°C to +85°C T _A = -40°C to +125°C
T _C Cold-Junction Accuracy (V _{DD} = 3.3V)	T _{C_ACY}	-1.0 -2.0	±0.5 ±1	+1.0 +2.0		°C
T_Δ Junctions Temperature Delta Accuracy – MCP9600/01						
Type K: T _Δ = -200°C to +1372°C V _{EMF} Range: -5.907 mV to 54.886 mV	T _{Δ_ACY}	-0.5	±0.25	+0.5	°C	T _A = 0°C to +85°C, V _{DD} = 3.3V (Note 2)
Type J: T _Δ = -150°C to +1200°C V _{EMF} Range: -3.336 mV to 47.476 mV						
Type T: T _Δ = -200°C to +400°C V _{EMF} Range: -5.603 mV to 20.81 mV						
Type N: T _Δ = -150°C to +1300°C V _{EMF} Range: -3.336 mV to 47.476 mV						
Type E: T _Δ = -200°C to +1000°C V _{EMF} Range: -8.825 mV to 76.298 mV						
Type S: T _Δ = 250°C to +1664°C V _{EMF} Range: -1.875 mV to 17.529 mV						
Type B: T _Δ = 1000°C to +1800°C V _{EMF} Range: -4.834 mV to 13.591 mV						T _A = 0°C to +85°C, V _{DD} = 3.3V (Notes 2, 3)
Type R: T _Δ = 250°C to +1664°C V _{EMF} Range: -1.923 mV to 19.732 mV						

- Note 1:** The T_C and T_Δ summation is implemented in milli-volt (mV) domain. The result, T_H (mV), is converted to Degree Celsius using the NIST ITS-90 Conversion database.
- 2:** The T_{Δ_ACY} temperature accuracy specification is defined as the device accuracy to the NIST ITS-90 Thermocouple EMF to Degree Celsius Conversion Database with T_C = 0°C.
- 3:** The device measures temperature below the specified range, however, the sensitivity to changes in temperature reduces exponentially. Type R and S measure down to -50°C, or -0.226 mV_{EMF} and -0.235 mV_{EMF}, respectively. Type B measures down to 500°C or 1.242 mV_{EMF} (see [Figures 2-7, 2-8, 2-10, 2-11, 2-14 and 2-17](#)).
- 4:** Exceeding the V_{IN_CM} input range may cause leakage current through the ESD protection diodes at the thermocouple input pins. This parameter is characterized but not production tested.
- 5:** The Minimum and Maximum %V_{DD} thresholds are characterized but not production tested.

MCP960X/L0X/RL0X

DC CHARACTERISTICS (CONTINUED)

Electrical Specifications: Unless otherwise indicated, $V_{DD} = 2.7V$ to $5.5V$, GND = Ground, $T_A = -40^{\circ}C$ to $+125^{\circ}C$ (where: $T_A = T_C$, defined as Device Ambient Temperature).						
Parameters	Sym.	Min.	Typ.	Max.	Unit	Conditions
Thermocouple Sensor Measurement Accuracy – MCP96L00/L01						
T_H Hot-Junction Accuracy ($V_{DD} = 3.3V$) $T_H = T_C + T_{\Delta}$ (Note 1)	T_{H_ACY}	-4.0	± 2	+4.0	$^{\circ}C$	$T_A = 0^{\circ}C$ to $+85^{\circ}C$
		-6.0	± 4	+6.0		$T_A = -40^{\circ}C$ to $+125^{\circ}C$
T_C Cold-Junction Accuracy ($V_{DD} = 3.3V$)	T_{C_ACY}	-1.0	± 0.5	+1.0	$^{\circ}C$	$T_A = 0^{\circ}C$ to $+85^{\circ}C$
		-2.0	± 1	+2.0		$T_A = -40^{\circ}C$ to $+125^{\circ}C$
T_{Δ} Junctions Temperature Delta Accuracy – MCP96L00/L01						
Type K: $T_{\Delta} = -200^{\circ}C$ to $+1372^{\circ}C$ V_{EMF} Range: -5.907 mV to 54.886 mV	T_{Δ_ACY}	-3.0	± 1.5	+3.0	$^{\circ}C$	$T_A = 0^{\circ}C$ to $+85^{\circ}C$, $V_{DD} = 3.3V$ (Note 2)
Type J: $T_{\Delta} = -150^{\circ}C$ to $+1200^{\circ}C$ V_{EMF} Range: -3.336 mV to 47.476 mV						
Type T: $T_{\Delta} = -200^{\circ}C$ to $+400^{\circ}C$ V_{EMF} Range: -5.603 mV to 20.81 mV						
Type N: $T_{\Delta} = -150^{\circ}C$ to $+1300^{\circ}C$ V_{EMF} Range: -3.336 mV to 47.476 mV						
Type E: $T_{\Delta} = -200^{\circ}C$ to $+1000^{\circ}C$ V_{EMF} Range: -8.825 mV to 76.298 mV						
Type S: $T_{\Delta} = 250^{\circ}C$ to $+1664^{\circ}C$ V_{EMF} Range: -1.875 mV to 17.529 mV						
Type B: $T_{\Delta} = 1000^{\circ}C$ to $+1800^{\circ}C$ V_{EMF} Range: -4.834 mV to 13.591 mV						
Type R: $T_{\Delta} = 250^{\circ}C$ to $+1664^{\circ}C$ V_{EMF} Range: -1.923 mV to 19.732 mV						$T_A = 0^{\circ}C$ to $+85^{\circ}C$ $V_{DD} = 3.3V$ (Notes 2, 3)

- Note 1:** The T_C and T_{Δ} summation is implemented in milli-volt (mV) domain. The result, T_H (mV), is converted to Degree Celsius using the NIST ITS-90 Conversion database.
- 2:** The T_{Δ_ACY} temperature accuracy specification is defined as the device accuracy to the NIST ITS-90 Thermocouple EMF to Degree Celsius Conversion Database with $T_C = 0^{\circ}C$.
- 3:** The device measures temperature below the specified range, however, the sensitivity to changes in temperature reduces exponentially. Type R and S measure down to $-50^{\circ}C$, or -0.226 mV_{EMF} and -0.235 mV_{EMF}, respectively. Type B measures down to $500^{\circ}C$ or 1.242 mV_{EMF} (see Figures 2-7, 2-8, 2-10, 2-11, 2-14 and 2-17).
- 4:** Exceeding the V_{IN_CM} input range may cause leakage current through the ESD protection diodes at the thermocouple input pins. This parameter is characterized but not production tested.
- 5:** The Minimum and Maximum % V_{DD} thresholds are characterized but not production tested.

DC CHARACTERISTICS (CONTINUED)

Electrical Specifications: Unless otherwise indicated, $V_{DD} = 2.7V$ to $5.5V$, GND = Ground, $T_A = -40^{\circ}C$ to $+125^{\circ}C$ (where: $T_A = T_C$, defined as Device Ambient Temperature).						
Parameters	Sym.	Min.	Typ.	Max.	Unit	Conditions
Thermocouple Sensor Measurement Accuracy – MCP96RL00/01						
T_H Hot-Junction Accuracy ($V_{DD} = 3.3V$) $T_H = T_C + T_{\Delta}$ (Note 1)	T_{H_ACY}	-8.0 -10.0	± 4 ± 6	+8.0 +10.0	$^{\circ}C$	$T_A = 0^{\circ}C$ to $+85^{\circ}C$ $T_A = -40^{\circ}C$ to $+125^{\circ}C$
T_C Cold-Junction Accuracy ($V_{DD} = 3.3V$)	T_{C_ACY}	-2.0	± 1	+2.0	$^{\circ}C$	$T_A = -40^{\circ}C$ to $+125^{\circ}C$
T_{Δ} Junctions Temperature Delta Accuracy – MCP96RL00/01						
Type K: $T_{\Delta} = -200^{\circ}C$ to $+1372^{\circ}C$ V_{EMF} Range: -5.907 mV to 54.886 mV	T_{Δ_ACY}	-6.0	± 3.0	+6.0	$^{\circ}C$	$T_A = 0^{\circ}C$ to $+85^{\circ}C$, $V_{DD} = 3.3V$ (Note 2)
Type J: $T_{\Delta} = -150^{\circ}C$ to $+1200^{\circ}C$ V_{EMF} Range: -3.336 mV to 47.476 mV						
Type T: $T_{\Delta} = -200^{\circ}C$ to $+400^{\circ}C$ V_{EMF} Range: -5.603 mV to 20.81 mV						
Type N: $T_{\Delta} = -150^{\circ}C$ to $+1300^{\circ}C$ V_{EMF} Range: -3.336 mV to 47.476 mV						
Type E: $T_{\Delta} = -200^{\circ}C$ to $+1000^{\circ}C$ V_{EMF} Range: -8.825 mV to 76.298 mV						
Type S: $T_{\Delta} = 250^{\circ}C$ to $+1664^{\circ}C$ V_{EMF} Range: -1.875 mV to 17.529 mV						
Type B: $T_{\Delta} = 1000^{\circ}C$ to $+1800^{\circ}C$ V_{EMF} Range: -4.834 mV to 13.591 mV						$T_A = 0^{\circ}C$ to $+85^{\circ}C$, $V_{DD} = 3.3V$ (Notes 2, 3)
Type R: $T_{\Delta} = 250^{\circ}C$ to $+1664^{\circ}C$ V_{EMF} Range: -1.923 mV to 19.732 mV						

- Note 1:** The T_C and T_{Δ} summation is implemented in milli-volt (mV) domain. The result, T_H (mV), is converted to Degree Celsius using the NIST ITS-90 Conversion database.
- Note 2:** The T_{Δ_ACY} temperature accuracy specification is defined as the device accuracy to the NIST ITS-90 Thermocouple EMF to Degree Celsius Conversion Database with $T_C = 0^{\circ}C$.
- Note 3:** The device measures temperature below the specified range, however, the sensitivity to changes in temperature reduces exponentially. Type R and S measure down to $-50^{\circ}C$, or -0.226 mV_{EMF} and -0.235 mV_{EMF}, respectively. Type B measures down to $500^{\circ}C$ or 1.242 mV_{EMF} (see Figures 2-7, 2-8, 2-10, 2-11, 2-14 and 2-17).
- Note 4:** Exceeding the V_{IN_CM} input range may cause leakage current through the ESD protection diodes at the thermocouple input pins. This parameter is characterized but not production tested.
- Note 5:** The Minimum and Maximum % V_{DD} thresholds are characterized but not production tested.

MCP960X/L0X/RL0X

DC CHARACTERISTICS (CONTINUED)

Electrical Specifications: Unless otherwise indicated, $V_{DD} = 2.7V$ to $5.5V$, $GND = \text{Ground}$, $T_A = -40^{\circ}\text{C}$ to $+125^{\circ}\text{C}$ (where: $T_A = T_C$, defined as Device Ambient Temperature).								
Parameters	Sym.	Min.	Typ.	Max.	Unit	Conditions		
Sensor Characteristics								
T_C and T_H Temperature Resolution	T_{RES}	—	± 0.0625	—	$^{\circ}\text{C}$	With max. resolution		
Sampling Rate ($T_A = +25^{\circ}\text{C}$)	t_{CONV}	—	320	—	ms	18-bit resolution		
		—	80	—		16-bit resolution		
		—	20	—		14-bit resolution		
		—	5	—		12-bit resolution		
Temperature Calculation Time	t_{CALC}	—	12	—	ms	$T_A = +25^{\circ}\text{C}$		
Thermocouple Input								
Offset Error	V_{OERR}	—	± 2	—	μV			
Offset Error Drift	V_{OE_DR}	—	50	—	$\text{nV}/^{\circ}\text{C}$			
Full-Scale Gain Error — MCP9600/01	G_{ERR}	—	—	± 0.04	%FS	$T_A = 0^{\circ}\text{C}$ to $+85^{\circ}\text{C}$		
Full-Scale Gain Error — MCP96L00/L01		—	± 0.12	—		$T_A = -40^{\circ}\text{C}$ to $+125^{\circ}\text{C}$		
Full-Scale Gain Error — MCP96RL00/RL01		—	± 0.24	—				
Full-Scale Gain Error Drift	G_{ER_DR}	—	± 0.01	—	%FS			
Full-Scale Integral Nonlinearity	INL	—	10	—	ppm			
Voltage Resolution	V_{RES}	—	2	—	μV	18-bit resolution		
Differential Mode Range	V_{IN_DF}	-250	—	+250	mV	ADC input range		
Differential Mode Impedance	Z_{IN_DF}	—	300	—	$\text{k}\Omega$			
Common-Mode Range	V_{IN_CM}	$V_{DD} - 0.3$	—	$V_{DD} + 0.3$	V	Note 4		
Common-Mode Impedance	Z_{IN_CM}	—	25	—	$\text{M}\Omega$			
Common-Mode Rejection Ratio	CMRR	—	105	—	dB			
Power Supply Rejection Ratio	PSRR	—	60	—	dB			
Line Regulation	V_{Line_R}	—	0.2	—	$^{\circ}\text{C}/\text{V}$			
Voltage Sense Input (V_{SENSE}) for Thermocouple Open and Short-Circuit Detection (MCP9601/L01/RL01)								
V_{SENSE} Input Range (Note 5)	V_{SIRNG}	0	—	100	% V_{DD}	(see Figure 1-1)		
		- Short Circuit to V_{DD}	V_{SiSC}	90		—	100	SC Alert Asserts
			0	—		10		
		- Open-Circuit	V_{SiOC}	19		—	50	OC Alert Asserts
		- Normal Operation	V_{SiNOR}	10		—	19	OC Alert Deasserts
V_{SENSE} Input Leakage	I_{SiLEAK}	—	0.1	1	μA			

- Note 1:** The T_C and T_A summation is implemented in milli-volt (mV) domain. The result, T_H (mV), is converted to Degree Celsius using the NIST ITS-90 Conversion database.
- 2:** The T_{A_ACY} temperature accuracy specification is defined as the device accuracy to the NIST ITS-90 Thermocouple EMF to Degree Celsius Conversion Database with $T_C = 0^{\circ}\text{C}$.
- 3:** The device measures temperature below the specified range, however, the sensitivity to changes in temperature reduces exponentially. Type R and S measure down to -50°C , or -0.226 mV_{EMF} and -0.235 mV_{EMF} , respectively. Type B measures down to 500°C or 1.242 mV_{EMF} (see [Figures 2-7, 2-8, 2-10, 2-11, 2-14 and 2-17](#)).
- 4:** Exceeding the V_{IN_CM} input range may cause leakage current through the ESD protection diodes at the thermocouple input pins. This parameter is characterized but not production tested.
- 5:** The Minimum and Maximum % V_{DD} thresholds are characterized but not production tested.

DC CHARACTERISTICS (CONTINUED)

Electrical Specifications: Unless otherwise indicated, $V_{DD} = 2.7V$ to $5.5V$, $GND = \text{Ground}$, $T_A = -40^\circ\text{C}$ to $+125^\circ\text{C}$ (where: $T_A = T_C$, defined as Device Ambient Temperature).

Parameters	Sym.	Min.	Typ.	Max.	Unit	Conditions
Alert 1, 2, 3, 4 Outputs, SC Alert and OC Alert Outputs (MCP9601/L01/RL01)						
Low-Level Voltage	V_{OL}	—	—	0.4	V	$I_{OL} = 3 \text{ mA}$
High-Level Voltage	V_{OH}	$V_{DD} - 0.5$	—	—	V	$I_{OH} = 3 \text{ mA}$
Operating Voltage and Current						
Operating Voltage	V_{DD}	2.7	—	5.5	V	
I^2C Inactive Current	I_{DD}	—	0.3	0.5	mA	$V_{DD} = 3.3V$, $T_A = +85^\circ\text{C}$
I^2C Active Current or During t_{CALC}		—	1.5	2.5	mA	
Shutdown Current	I_{SHDN}	—	2	5	μA	I^2C inactive, $T_A = +85^\circ\text{C}$
Power-on Reset (POR) Thresholds	V_{POR}	1.0	2.1	2.6	V	Rising/Falling V_{DD}
Power-up Time	t_{POR}	—	20	—	ms	
Thermal Response						
Package Thermal Response (Time to 63% of Final Temperature)	t_{RSP}	—	3	—	s	$+25^\circ\text{C}$ (air) to $+125^\circ\text{C}$ (oil bath), $2 \times 2''$ PCB

- Note 1:** The T_C and T_A summation is implemented in milli-volt (mV) domain. The result, T_H (mV), is converted to Degree Celsius using the NIST ITS-90 Conversion database.
- Note 2:** The $T_{\Delta ACY}$ temperature accuracy specification is defined as the device accuracy to the NIST ITS-90 Thermocouple EMF to Degree Celsius Conversion Database with $T_C = 0^\circ\text{C}$.
- Note 3:** The device measures temperature below the specified range, however, the sensitivity to changes in temperature reduces exponentially. Type R and S measure down to -50°C , or -0.226 mV_{EMF} and -0.235 mV_{EMF} , respectively. Type B measures down to 500°C or 1.242 mV_{EMF} (see Figures 2-7, 2-8, 2-10, 2-11, 2-14 and 2-17).
- Note 4:** Exceeding the V_{IN_CM} input range may cause leakage current through the ESD protection diodes at the thermocouple input pins. This parameter is characterized but not production tested.
- Note 5:** The Minimum and Maximum $\%V_{DD}$ thresholds are characterized but not production tested.

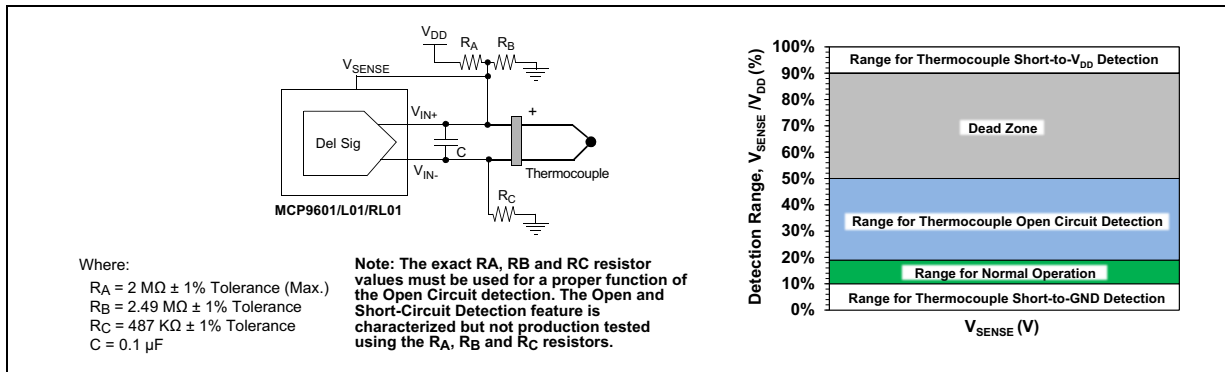

FIGURE 1-1: Open and Short-Circuit Detection Configuration.

MCP960X/L0X/RL0X

INPUT/OUTPUT PIN DC CHARACTERISTICS

Electrical Specifications: Unless otherwise indicated, $V_{DD} = 2.7V$ to $5.5V$, GND = Ground, $T_A = -40^{\circ}C$ to $+125^{\circ}C$ (where: $T_A = T_C$, defined as Device Ambient Temperature).						
Parameters	Sym.	Min.	Typ.	Max.	Units	Conditions
Serial Input/Output and I²C Address Input (ADDR)						
Input (SCL, SDA, ADDR)						
High-Level Voltage	V_{IH}	$0.7 \times V_{DD}$	—	—	V	
Low-Level Voltage	V_{IL}	—	—	$0.3 \times V_{DD}$	V	
Input Current	I_{LEAK}	—	—	± 2	μA	
Hysteresis	V_{HYST}	—	$0.05 \times V_{DD}$	—	V	$V_{DD} > 2V$
Spike Suppression	T_{SP}	—	50	—	ns	
Output (SDA)						
Low-Level Voltage	V_{OL}	—	—	0.4	V	$I_{OL} = 3\text{ mA}$
High-Level Current (leakage)	I_{OH}	—	—	1	μA	$V_{OH} = V_{DD}$
Low-Level Current	I_{OL}	6	—	—	mA	$V_{OL} = 0.6V$
Capacitance	C_{IN}	—	5	—	pF	
I²C Address Selection Levels (Note 1)						
Command Byte [1100 000x]	V_{ADDR}	GND	—	—	V	Address = 0
Command Byte [1100 001x]		V_{ADDR_L}	V_{ADDR_TYP}	V_{ADDR_H}		Address = 1
Command Byte [1100 010x]		(Note 2)	(Note 2)	(Note 2)		Address = 2
Command Byte [1100 011x]						Address = 3
Command Byte [1100 100x]						Address = 4
Command Byte [1100 101x]						Address = 5
Command Byte [1100 110x]						Address = 6
Command Byte [1100 111x]						—

Note 1 The ADDR pin can be tied to V_{DD} or V_{SS} . For additional addresses, a resistive divider network can be used to set voltage levels that are rationed to V_{DD} . The device supports up to eight levels (see [Section 6.3.1 “I²C Addressing”](#) for recommended resistor values).

- 2** $V_{ADDR_TYP} = \text{Address} * V_{DD}/8 + V_{DD}/16$,
 $V_{ADDR_L} = V_{ADDR_TYP} - V_{DD}/32$ and
 $V_{ADDR_H} = V_{ADDR_TYP} + V_{DD}/32$ (where: Address = 1, 2, 3, 4, 5, 6).

TEMPERATURE CHARACTERISTICS

Electrical Specifications: Unless otherwise indicated, $V_{DD} = 2.7V$ to $5.5V$, GND = Ground.						
Parameters	Sym.	Min.	Typ.	Max.	Units	Conditions
Temperature Ranges						
Specified Temperature Range	T_A	-40	—	+125	$^{\circ}C$	Note 1
Operating Temperature Range	T_A	-40	—	+125	$^{\circ}C$	
Storage Temperature Range	T_A	-65	—	+150	$^{\circ}C$	
Thermal Package Resistances						
Thermal Resistance, MQFN	θ_{JA}	—	38.8	—	$^{\circ}C/W$	

Note 1 Operation in this range must not cause T_J to exceed the Maximum Junction Temperature (+150 $^{\circ}C$).

SENSOR SERIAL INTERFACE TIMING SPECIFICATIONS

Electrical Specifications: Unless otherwise indicated, GND = Ground, $T_A = -40^\circ\text{C}$ to $+125^\circ\text{C}$, $V_{DD} = 2.7\text{V}$ to 5.5V and $C_L = 80\text{ pF}$ (**Note 1**).

Parameters	Sym.	Min.	Max.	Units
Two-Wire I²C Interface				
Serial Port Frequency	f_{SCL}	10	100	kHz
Low Clock (Note 2)	t_{LOW}	4700	—	ns
High Clock	t_{HIGH}	4000	—	ns
Rise Time (Note 3)	t_R	—	1000	ns
Fall Time (Note 3)	t_F	20	300	ns
Data in Setup Time (Note 2)	$t_{SU:DAT}$	250	—	ns
Data in Hold Time	$t_{HD:DAT}$	0	—	ns
Start Condition Setup Time	$t_{SU:STA}$	4700	—	ns
Start Condition Hold Time	$t_{HD:STA}$	4000	—	ns
Stop Condition Setup Time	$t_{SU:STO}$	4000	—	ns
Bus Idle/Free	t_{B-FREE}	10	—	μs
Bus Capacitive Load	C_b	—	400	pf
Clock Stretching (Note 4)	$t_{STRETCH}$	60	—	μs

Note 1 All values referred to $V_{IL\ MAX}$ and $V_{IH\ MIN}$ levels.

2 This device can be used in a Standard mode I²C bus system, but the requirement, $t_{SU:DAT} \geq 250\text{ ns}$, must be met.

3 Characterized, but not production tested.

4 Host controllers without features to detect clock stretching by device should increase the t_{LOW} period for Read Commands to a minimum of $t_{STRETCH}$ (60 μs) for a proper I²C communication. See [Figure 2-29](#) for a typical $t_{STRETCH}$ performance.

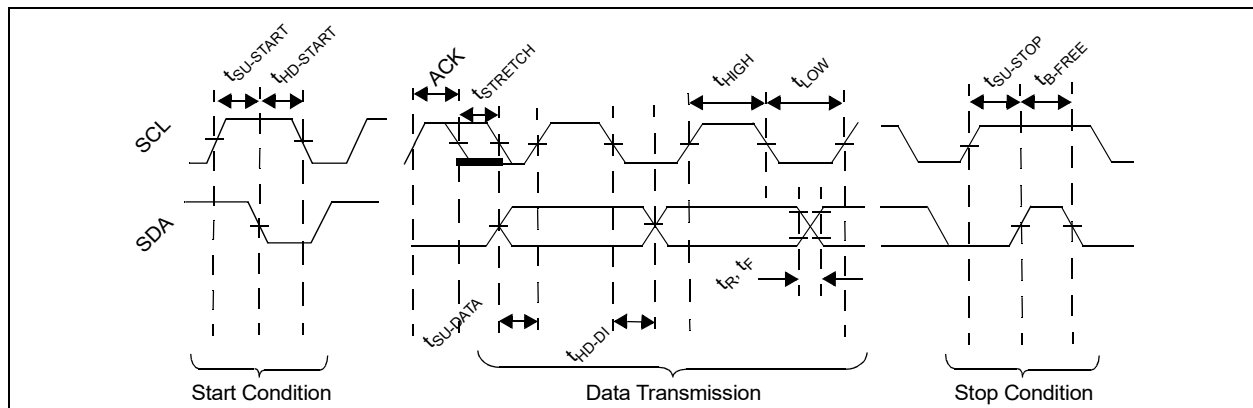

FIGURE 1-2: Timing Diagram.

NOTES:

2.0 TYPICAL PERFORMANCE CURVES

Note: The graphs and tables provided following this note are a statistical summary based on a limited number of samples and are provided for informational purposes only. The performance characteristics listed herein are not tested or guaranteed. In some graphs or tables, the data presented may be outside the specified operating range (e.g., outside specified power supply range) and therefore, outside the warranted range.

Note: Unless otherwise indicated, $V_{DD} = 2.7V$ to $5.5V$, GND = Ground, SDA/SCL pulled-up to V_{DD} and $T_A = -40^{\circ}C$ to $+125^{\circ}C$.

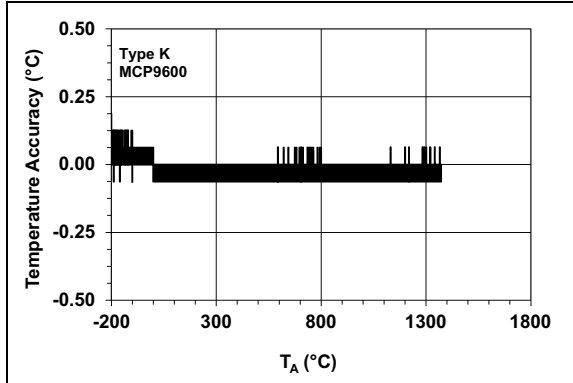

FIGURE 2-1: Typical Temperature Accuracy from NIST ITS-90 Database, Type K.

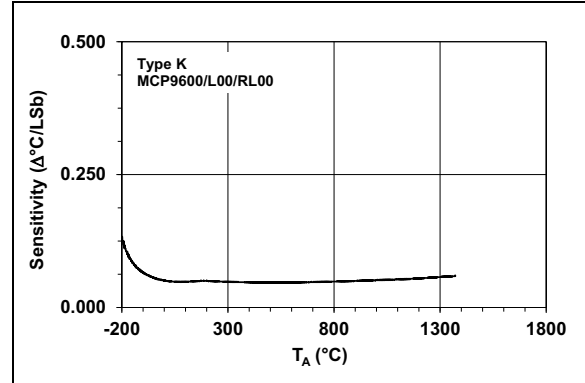

FIGURE 2-4: Temperature Sensitivity with 18-Bit Resolution, Type K.

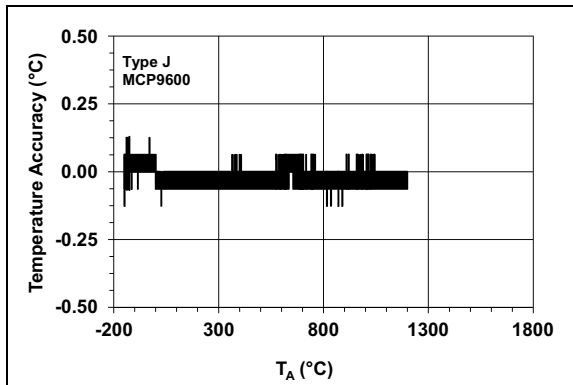

FIGURE 2-2: Typical Temperature Accuracy from NIST ITS-90 Database, Type J.

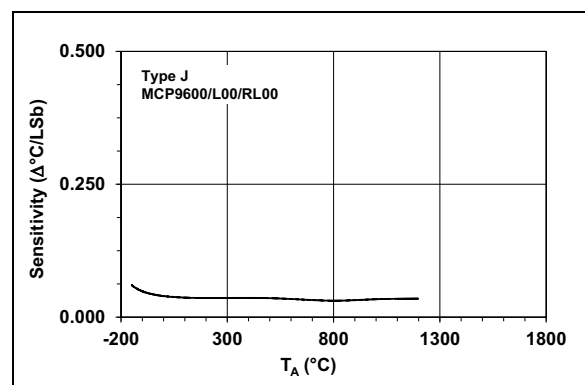

FIGURE 2-5: Temperature Sensitivity with 18-Bit Resolution, Type J.

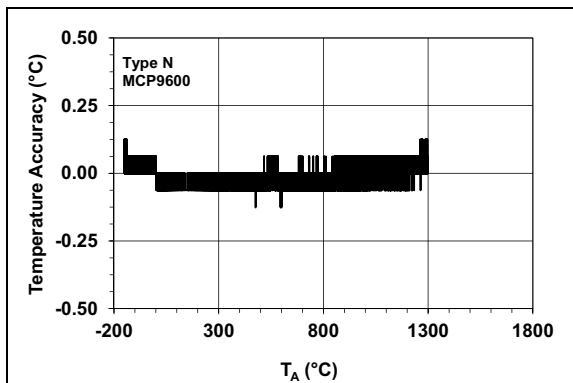

FIGURE 2-3: Typical Temperature Accuracy from NIST ITS-90 Database, Type N.

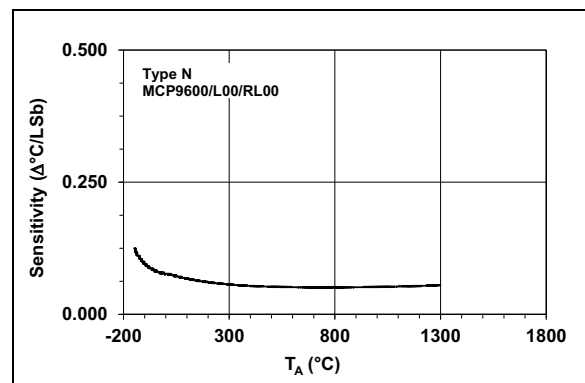

FIGURE 2-6: Temperature Sensitivity with 18-Bit Resolution, Type N.

MCP960X/L0X/RL0X

Note: Unless otherwise indicated, $V_{DD} = 2.7V$ to $5.5V$, GND = Ground, SDA/SCL pulled-up to V_{DD} and $T_A = -40^{\circ}C$ to $+125^{\circ}C$.

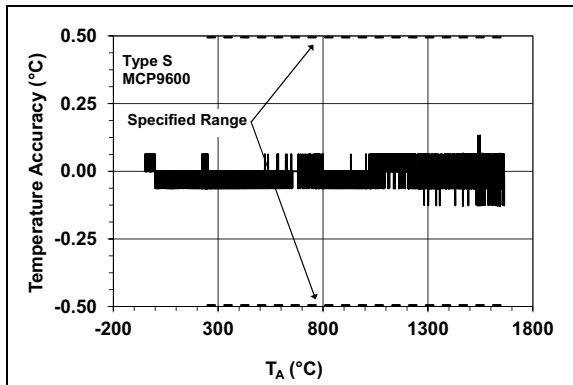

FIGURE 2-7: Typical Temperature Accuracy from NIST ITS-90 Database, Type S.

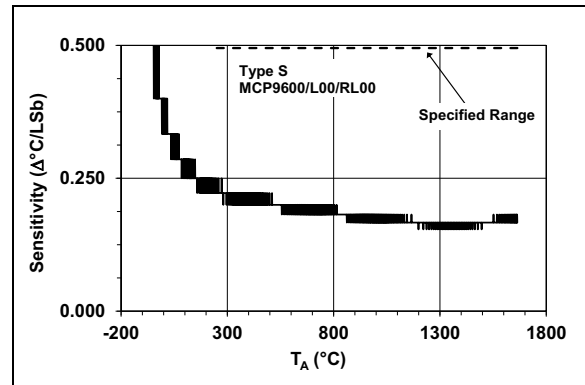

FIGURE 2-10: Temperature Sensitivity with 18-Bit Resolution, Type S.

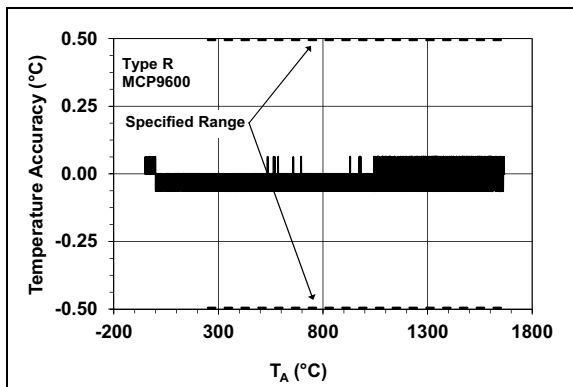

FIGURE 2-8: Typical Temperature Accuracy from NIST ITS-90 Database, Type R.

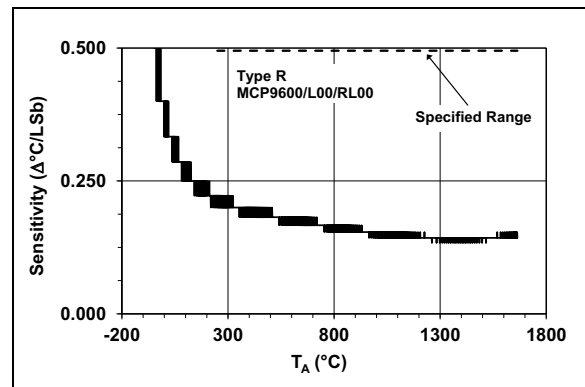

FIGURE 2-11: Temperature Sensitivity with 18-Bit Resolution, Type R.

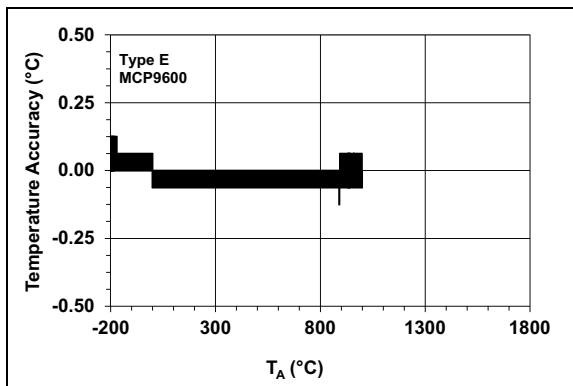

FIGURE 2-9: Typical Temperature Accuracy from NIST ITS-90 Database, Type E.

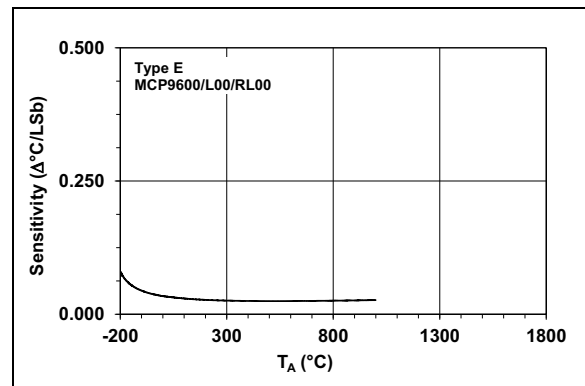

FIGURE 2-12: Temperature Sensitivity with 18-Bit Resolution, Type E.

MCP960X/L0X/RL0X

Note: Unless otherwise indicated, $V_{DD} = 2.7V$ to $5.5V$, GND = Ground, SDA/SCL pulled-up to V_{DD} and $T_A = -40^{\circ}C$ to $+125^{\circ}C$.

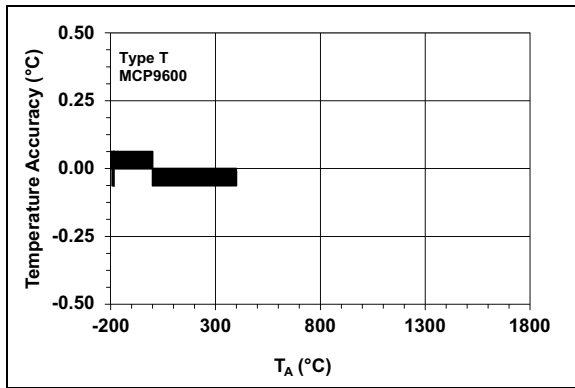

FIGURE 2-13: Typical Temperature Accuracy from NIST ITS-90 Database, Type T.

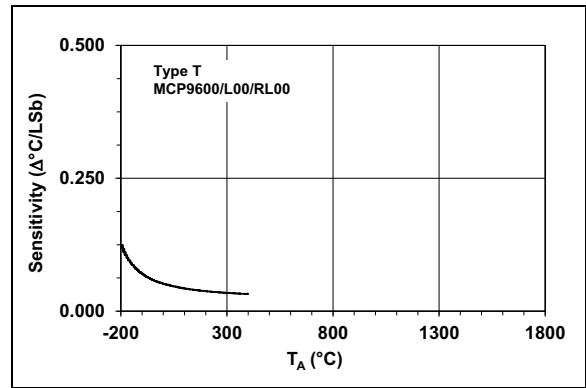

FIGURE 2-16: Temperature Sensitivity with 18-Bit Resolution, Type T.

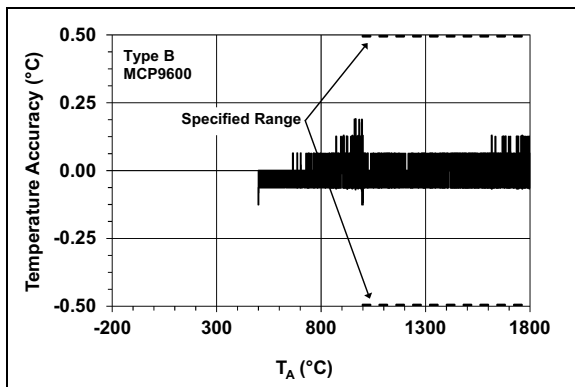

FIGURE 2-14: Typical Temperature Accuracy from NIST ITS-90 Database, Type B.

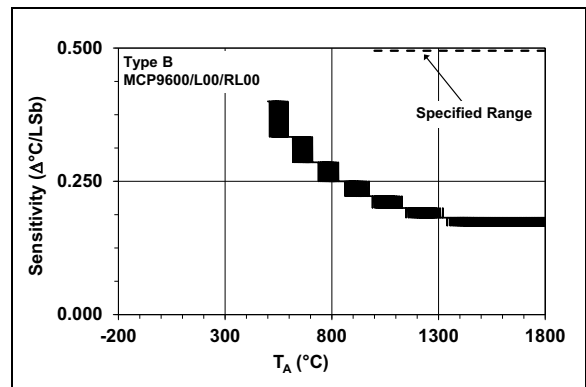

FIGURE 2-17: Temperature Sensitivity with 18-Bit Resolution, Type B.

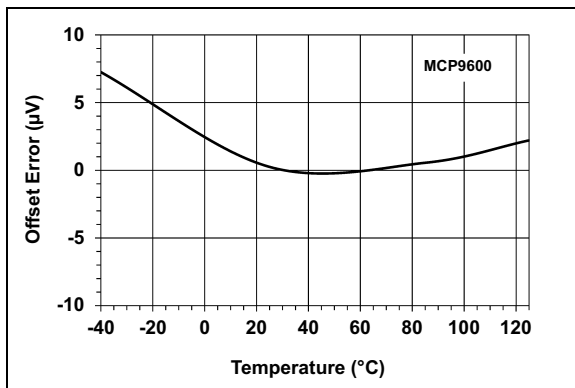

FIGURE 2-15: Input Offset Error Voltage (V_{IN+} , V_{IN-}).

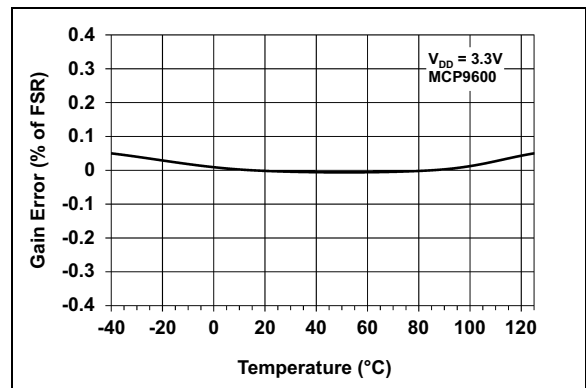

FIGURE 2-18: Full-Scale Gain Error.

MCP960X/L0X/RL0X

Note: Unless otherwise indicated, $V_{DD} = 2.7V$ to $5.5V$, GND = Ground, SDA/SCL pulled-up to V_{DD} and $T_A = -40^\circ C$ to $+125^\circ C$.

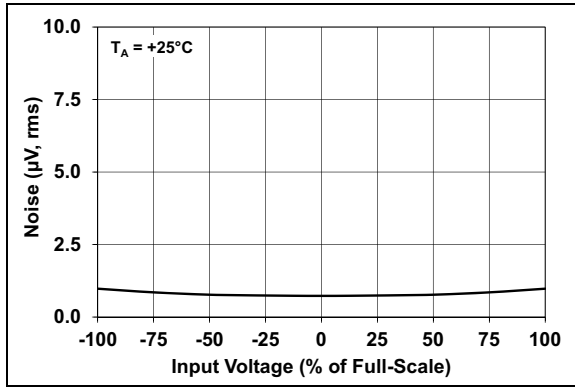

FIGURE 2-19: Input Noise, % of Full Scale.

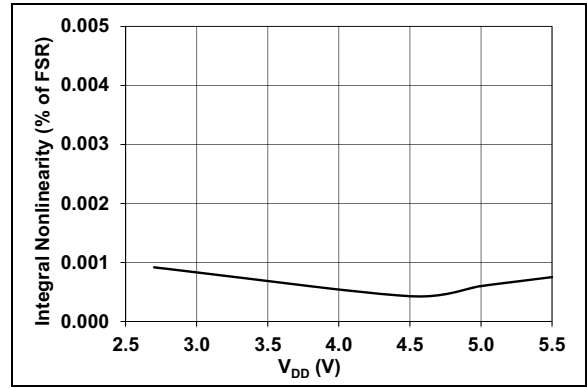

FIGURE 2-22: Integral Nonlinearity Across V_{DD} .

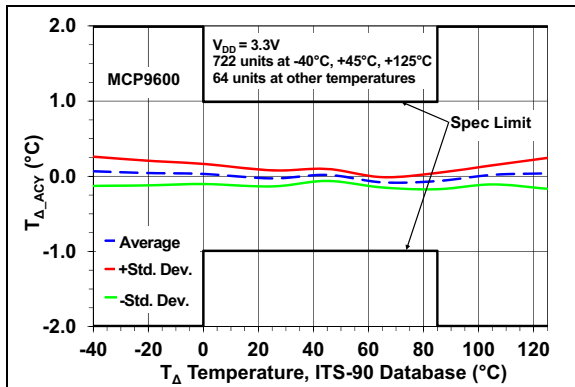

FIGURE 2-20: Cold-Junction Sensor Temperature Accuracy.

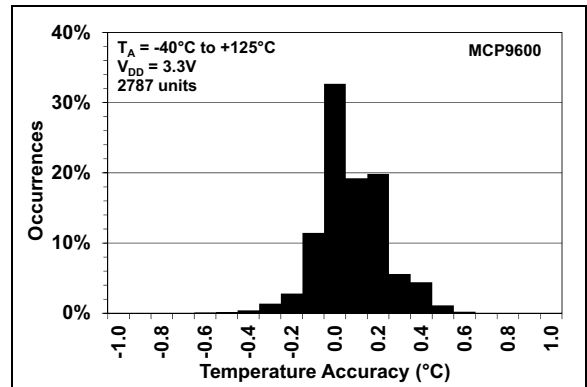

FIGURE 2-23: Cold-Junction Sensor Temperature Accuracy Distribution.

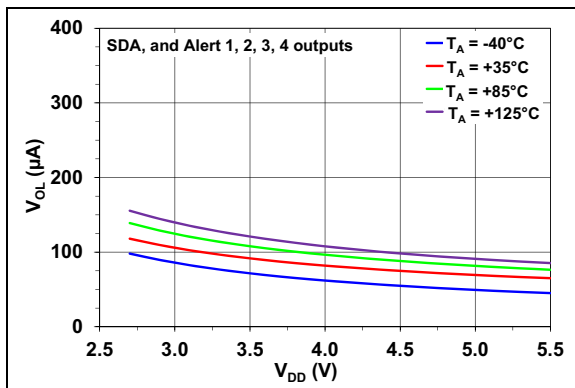

FIGURE 2-21: SDA and Alert Outputs, V_{OL} Across V_{DD} .

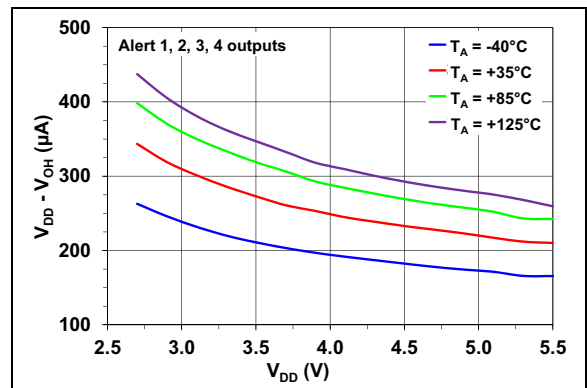

FIGURE 2-24: Alert Outputs, V_{OH} Across V_{DD} .

MCP960X/L0X/RL0X

Note: Unless otherwise indicated, $V_{DD} = 2.7V$ to $5.5V$, GND = Ground, SDA/SCL pulled-up to V_{DD} and $T_A = -40^\circ C$ to $+125^\circ C$.

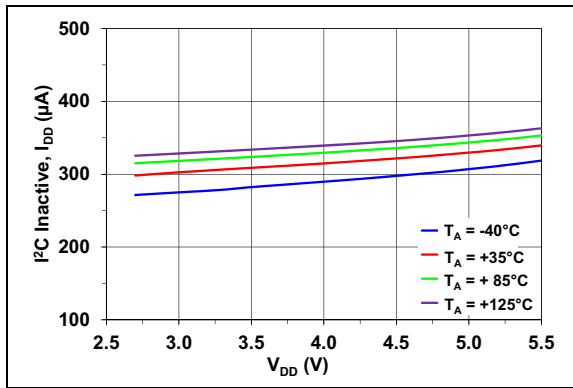

FIGURE 2-25: I^2C Inactive, I_{DD} Across V_{DD} .

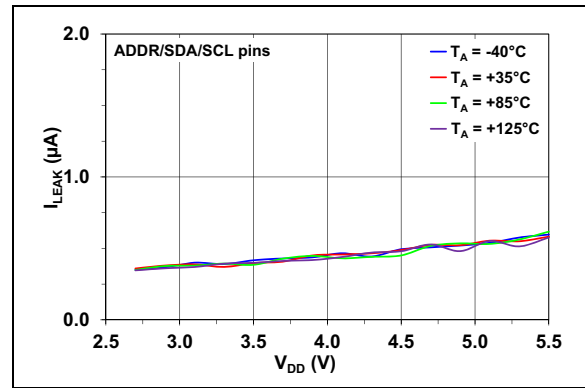

FIGURE 2-28: SDA, SCL and ADDR Input Pins Leakage Current, I_{LEAK} Across V_{DD} .

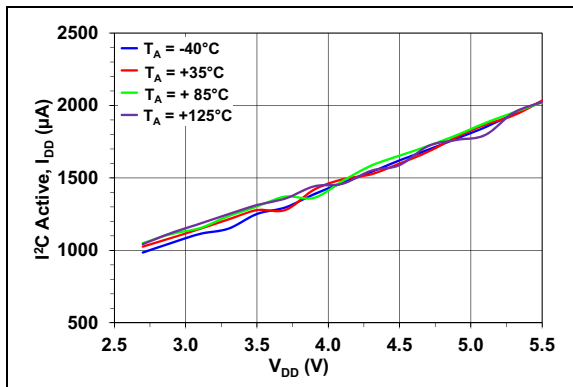

FIGURE 2-26: I^2C Active, I_{DD} Across V_{DD} .

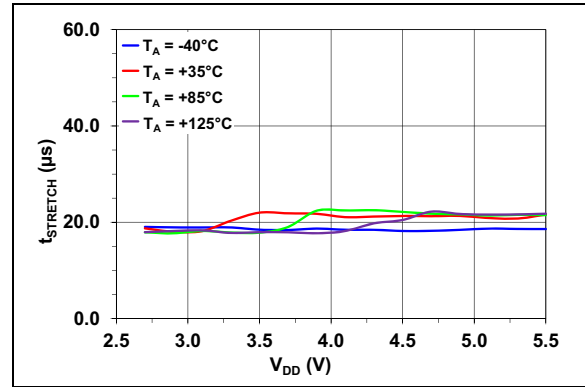

FIGURE 2-29: I^2C Interface Clock Stretch Duration, $t_{STRETCH}$ Across V_{DD} .

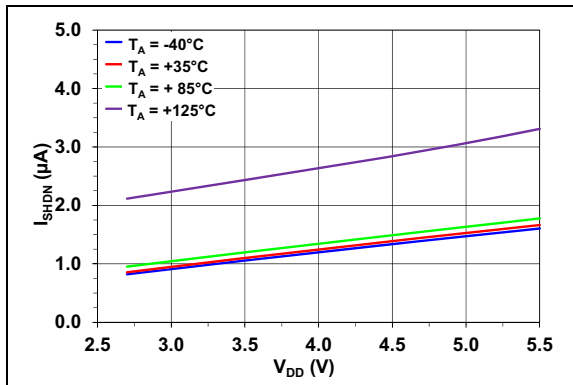

FIGURE 2-27: Shutdown Current, I_{SHDN} Across V_{DD} .

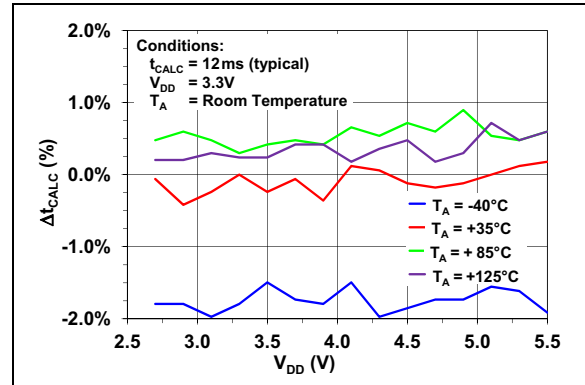

FIGURE 2-30: Temperature Calculation Duration, t_{CALC} Change Across V_{DD} .

NOTES:

3.0 PIN DESCRIPTIONS

The descriptions of the pins are listed in [Table 3-1](#).

TABLE 3-1: PIN FUNCTION TABLE

MCP9600/L00/RL00	MCP9601/L01/RL01	Symbol	Pin Function
1, 3, 5, 13, 17	1, 3, 5, 13, 17	GND	Electrical Ground
2	2	V _{IN+}	Thermocouple Positive Terminal Input
4	4	V _{IN-}	Thermocouple Negative Terminal Input
6, 7, 9, 10, 18	10, 18	GND	Not Electrical Ground; must be tied to Ground
—	6	V _{SENSE}	Thermocouple Open and Short-Circuit detection input
—	7	SC Alert	Thermocouple Short-Circuit Alert Output
8	8	V _{DD}	Power
—	9	OC Alert	Thermocouple Open-Circuit Alert Output
11	11	Alert 1	Alert Output 1
12	12	Alert 2	Alert Output 2
14	14	Alert 3	Alert Output 3
15	15	Alert 4	Alert Output 4
16	16	ADDR	I ² C Device Address Selection Voltage Input
19	19	SCL	I ² C Clock Input
20	20	SDA	I ² C Data Input
21	21	EP	Exposed Thermal Pad (EP); must be connected to GND

3.1 Ground Pin (GND)

The GND pin is the system ground pin. Pins 1, 3, 5, 13 and 17 are system ground pins and they are at the same potential. However, pins 6, 7, 9, 10 and 18 must be connected to ground for normal operation.

The Open-Circuit (OC) Alert and the Short-Circuit (SC) Alert output are also active-high push-pull outputs (MCP9601/L01/RL01). These outputs are asserted when Open-Circuit and Short-Circuit conditions are detected on the V_{SENSE} pin.

3.2 Thermocouple Input (V_{IN+}, V_{IN-})

The thermocouple wires are directly connected to these inputs. The positive node is connected to the V_{IN+} pin, while the negative node connects to the V_{IN-} node. The thermocouple voltage is converted to degree Celsius.

3.3 Power Pin (V_{DD})

V_{DD} is the power pin. The operating voltage range, as specified in the DC Characteristics table, is applied on this pin.

3.4 Push-Pull Alert Outputs (Alert 1, 2, 3, 4 and OC/SC Alert)

The Alert pins are user-programmable push-pull outputs which can be used to detect rising or falling temperatures. The device outputs signal when the ambient temperature exceeds the user-programmed temperature alert limit.

3.5 I²C Address Pin (ADDR)

This pin is used to set the I²C address. This pin can be tied to V_{DD}, GND, or a ratio of V_{DD} can be selected to set up to eight address levels using a resistive voltage divider network.

3.6 Serial Clock Line (SCL)

The SCL is a clock input pin. All communication and timing is relative to the signal on this pin. The clock is generated by the host controller on the bus (see [Section 4.0 “Serial Communication”](#)).

3.7 Serial Data Line (SDA)

SDA is a bidirectional input/output pin used to serially transmit data to/from the host controller. This pin requires a pull-up resistor (see [Section 4.0 “Serial Communication”](#)).

3.8 Thermocouple Open/Short Detection Input (V_{SENSE})

The V_{SENSE} pin is a thermocouple detection input pin (MCP9601/L01/RL01) and the voltage level on this pin is used to determine whether the thermocouple is operating normally, shorted to V_{DD}/V_{SS}, or it is disconnected from the V_{IN+} and V_{IN-} pins (see [Figure 1-1](#)).

NOTES:

4.0 SERIAL COMMUNICATION

4.1 Two-Wire Standard Mode I²C Protocol-Compatible Interface

The MCP960X/L0X/RL0X Serial Clock Input (SCL) and the bidirectional Serial Data Line (SDA) form a two-wire bidirectional data communication line (refer to the [Input/Output Pin DC Characteristics](#) table and [Sensor Serial Interface Timing Specifications](#) table).

The following bus protocol has been defined:

TABLE 4-1: MCP960X/L0X/RL0X SERIAL BUS PROTOCOL DESCRIPTIONS

Term	Description
Host	The device that controls the serial bus, typically a microcontroller
Device	The device addressed by the host, such as the MCP960X/L0X/RL0X
Transmitter	Device sending data to the bus
Receiver	Device receiving data from the bus
START	A unique signal from host to initiate serial interface with a device
STOP	A unique signal from the host to terminate serial interface from a device
Read/Write	A read or write to the MCP960X/L0X/RL0X registers
ACK	A receiver Acknowledges (ACK) the reception of each byte by polling the bus
NAK	A receiver Not Acknowledges (NAK) or releases the bus to show End-of-Data (EOD)
Busy	Communication is not possible because the bus is in use
Not Busy	The bus is in the Idle state, both SDA and SCL remain high
Data Valid	SDA must remain stable before SCL becomes high in order for a data bit to be considered valid. During normal data transfers, SDA only changes state while SCL is low.

4.1.1 DATA TRANSFER

Data transfers are initiated by a Start condition (START), followed by a 7-bit device address and a read/write bit. An Acknowledge (ACK) from the device confirms the reception of each byte. Each access must be terminated by a Stop condition (STOP).

Repeated communication is initiated after t_{B-FREE} .

This device supports the Receive Protocol. The register can be specified using the pointer for the initial read. Each repeated read or receive begins with a Start condition and address byte. The MCP960X/L0X/RL0X retains the previously selected register. Therefore, it outputs data from the previously-specified register (repeated pointer specification is not necessary).

4.1.2 HOST/DEVICE

The bus is controlled by a host device (typically a microcontroller) that controls the bus access, and generates the Start and Stop conditions. The MCP960X/L0X/RL0X is a device and does not control other devices in the bus. Both host and device can operate as either transmitter or receiver. However, the host device determines which mode is activated.

4.1.3 START/STOP CONDITION

A high-to-low transition of the SDA line (while SCL is high) is the Start condition. All data transfers must be preceded by a Start condition from the host. A low-to-high transition of the SDA line (while SCL is high) signifies a Stop condition.

If a Start or Stop condition is introduced during data transmission, the MCP960X/L0X/RL0X releases the bus. All data transfers are ended by a Stop condition from the host.

4.1.4 ADDRESS BYTE

Following the Start condition, the host must transmit an 8-bit address byte to the MCP960X/L0X/RL0X. The address for the MCP960X/L0X/RL0X temperature sensor is '11, 0, 0, A2, A1, A0' in binary, where the A2, A1 and A0 bits are set externally by connecting the corresponding V_{ADDR} voltage levels on the ADDR pin (see the ["Input/Output Pin DC Characteristics"](#) section). The 7-bit address transmitted in the serial bit stream must match the selected address for the MCP960X/L0X/RL0X to respond with an ACK. Bit 8 in the address byte is a read/write bit. Setting this bit to '1' commands a read operation, while '0' commands a write operation (see [Figure 4-1](#)).

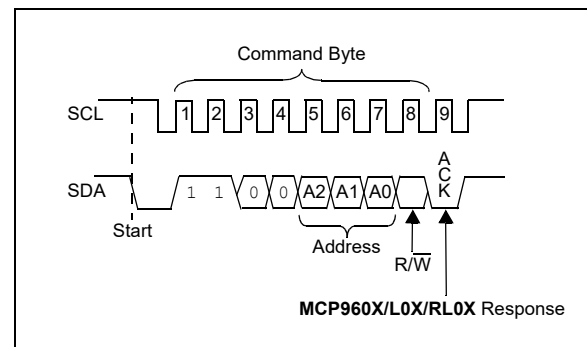

FIGURE 4-1: Device Addressing.

4.1.5 DATA VALID

After the Start condition, each bit of data in transmission needs to be settled for a time specified by $t_{SU-DATA}$ before SCL toggles from low-to-high (see the “[Sensor Serial Interface Timing Specifications](#)” section).

4.1.6 ACKNOWLEDGE (ACK/NAK)

Each receiving device, when addressed, is expected to generate an ACK bit after the reception of each byte. The host device must generate an extra clock pulse for ACK to be recognized.

The Acknowledging device pulls down the SDA line for $t_{SU-DATA}$ before the low-to-high transition of SCL from the host. SDA also needs to remain pulled down for t_{HD-DAT} after a high-to-low transition of SCL.

During read, the host must signal an End-of-Data (EOD) to the device by not generating an ACK bit (NAK) once the last bit has been clocked out of the device. In this case, the device will leave the data line released to enable the host to generate the Stop condition.

4.1.7 CLOCK STRETCHING

During the I²C read operation, this device will hold the I²C clock line low for t_{STRECH} after the falling edge of the ACK signal. In order to prevent bus contention, the host controller must release or hold the SCL line low during this period.

Note: If the host controller does not provide the adequate delay as specified by t_{STRECH} , then the device will output the previously transmitted data.

In addition, the host controller must provide eight consecutive clock cycles after generating the ACK bit from a read command. This allows the device to push out data from the SDA Output Shift registers. Missing clock cycles could result in bus contention. At the end of one or more data transmission, the host controller must provide the NAK bit, followed by a Stop Condition to terminate communication (see [Figure 4-3](#)).

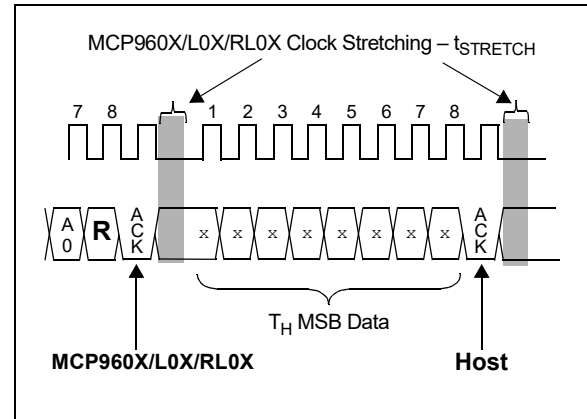

FIGURE 4-2: Clock Stretching.

4.1.8 SEQUENTIAL READ

During a sequential read, the device transmits data bytes starting from the previously set Register Pointer. The MCP960X/L0X/RL0X increments an internal address pointer each time a byte transmission is successfully completed with an ACK bit from the host controller. Therefore, the device can sequentially output the entire register values shown in [Table 5-1](#) (see [Figure 4-6](#)). A Stop Condition terminates the sequential read.

Note: The MCP960X/L0X/RL0X does not support Sequential Write function.

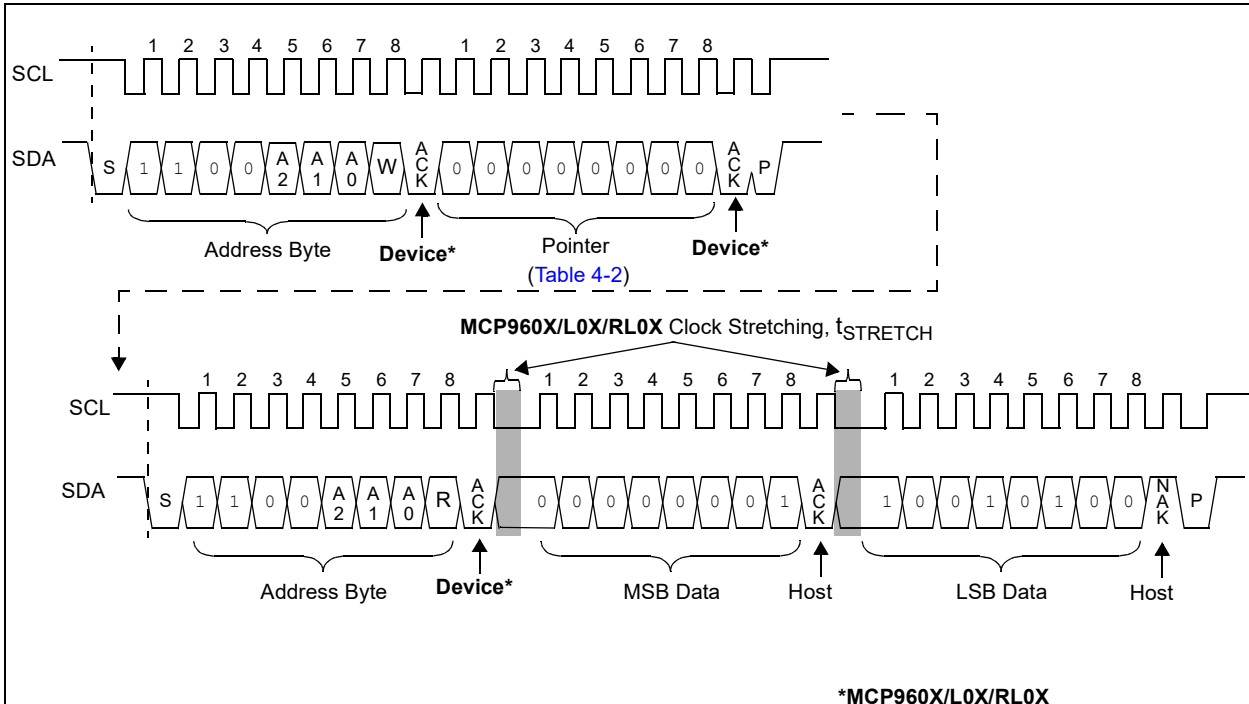

TABLE 4-2: POINTERS

Read-Only Registers	Pointer
T _H	0000 0000
T _Δ	0000 0001
T _C	0000 0010

Note: this is an example pseudo routine:

```

i2c_start(); // send START command
i2c_write(b'1100 0000'); // WRITE Command
// also, make sure bit 0 is cleared '0'
i2c_write(b'0000 00XX'); // Write TH, TΔ, or TC registers
i2c_stop(); // send STOP command
i2c_start(); // send START command
i2c_write(b'1100 0001'); // READ Command
// also, make sure bit 0 is set '1'
UpperByte = i2c_read(ACK); // READ 8 bits (with tSTRETCH delay)
// and Send ACK bit
LowerByte = i2c_read(NAK); // READ 8 bits (with tSTRETCH delay)
// and Send NAK bit
i2c_stop(); // send STOP command

//Convert the temperature data
if ((UpperByte & 0x80) == 0x80) { //Temperature < 0°C
    Temperature = (UpperByte x 16 + LowerByte / 16) - 4096;
} else //Temperature ≥ 0°C
    Temperature = (UpperByte x 16 + LowerByte / 16);
//TH, TD, or TC Temperature (°C) depending on the register pointer value shown in Table 4-2.
    
```

FIGURE 4-3: Timing Diagram to Set a Register Pointer and Read a Two-Byte Data.

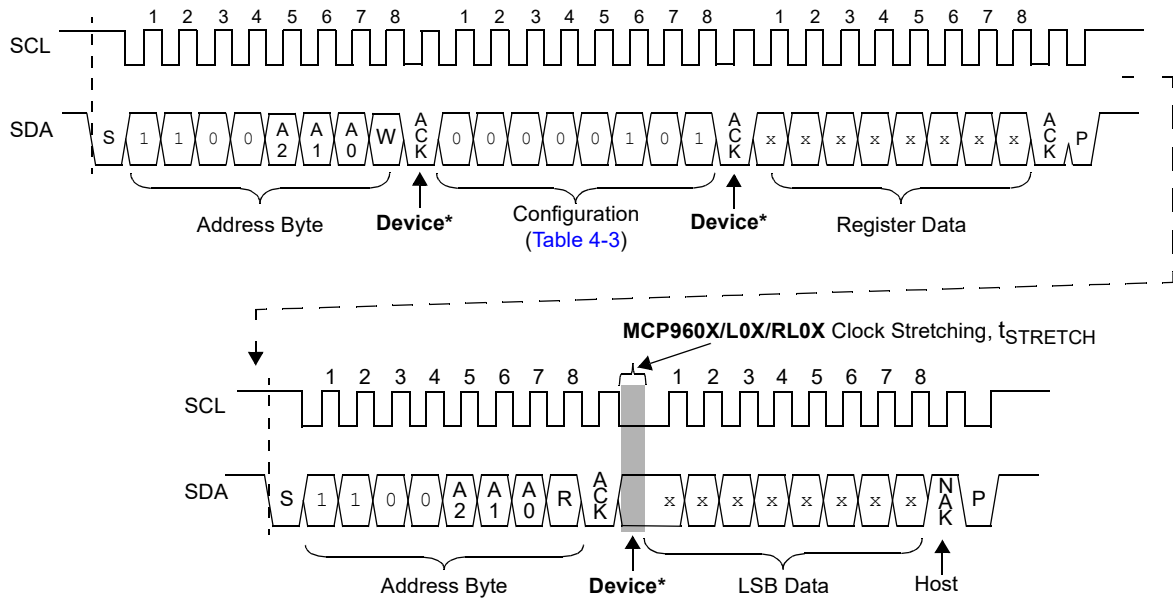

TABLE 4-3: POINTERS

Read/Write Registers	Pointer
STATUS	0000 0100
Configuration	0000 0101
	0000 0110

*MCP960X/L0X/RL0X

Note: this is an example pseudo routine:

```

i2c_start(); // send START command
i2c_write(b'1100 0000'); // WRITE Command
// also, make sure bit 0 is cleared '0'
i2c_write(b'0000 0101'); // Write Status or Configuration registers
i2c_write(b'XXXX XXXX'); // Write register data
i2c_stop(); // send STOP command
i2c_start(); // send START command
i2c_write(b'1100 0001'); // READ Command
// also, make sure bit 0 is set '1'
Data = i2c_read(NAK); // READ 8 bits (with tSTRETCH delay)
// and Send NAK bit
i2c_stop(); // send STOP command
    
```

FIGURE 4-4: Timing Diagram to Set a Register Pointer, Write One Byte, and Read the Data.

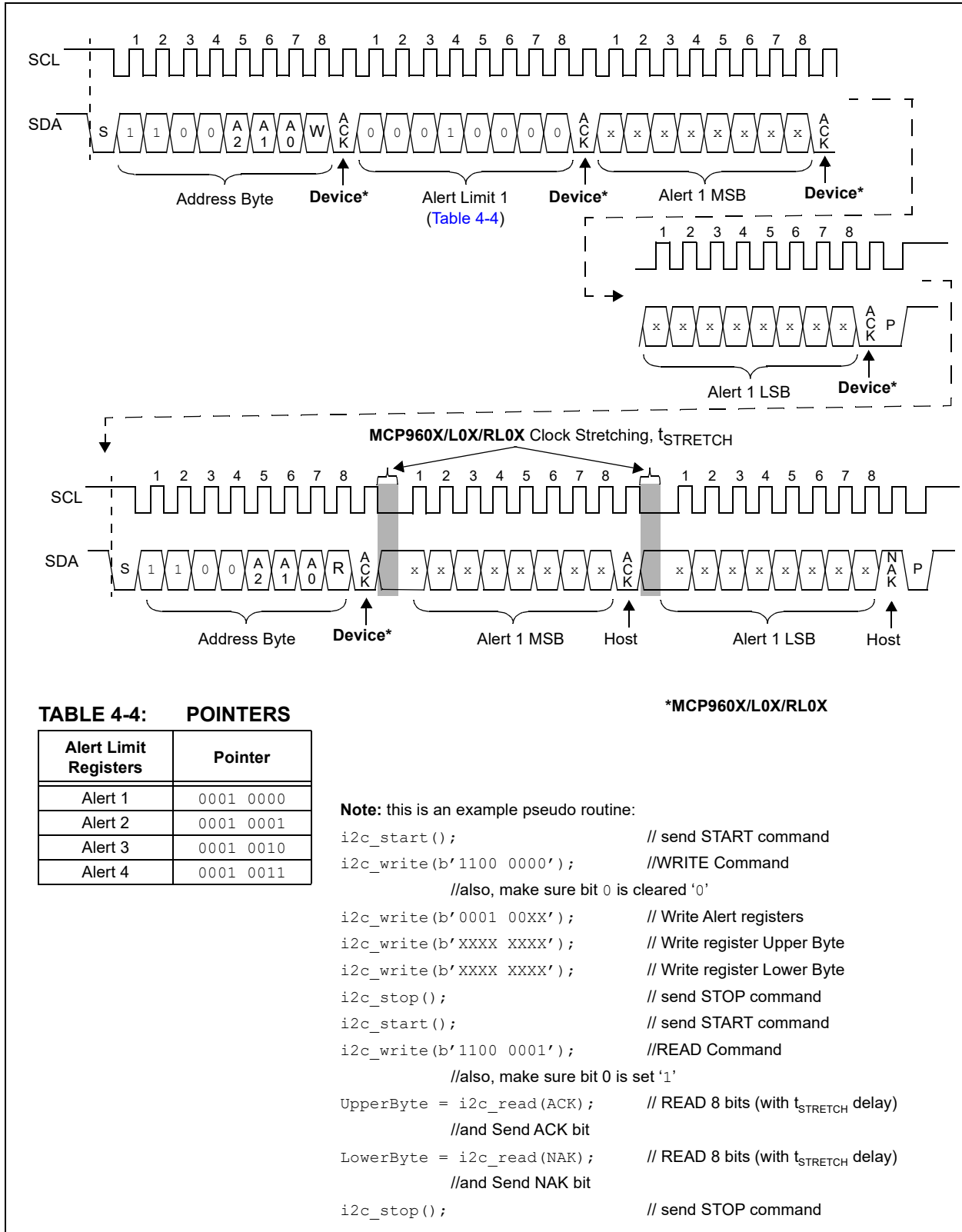
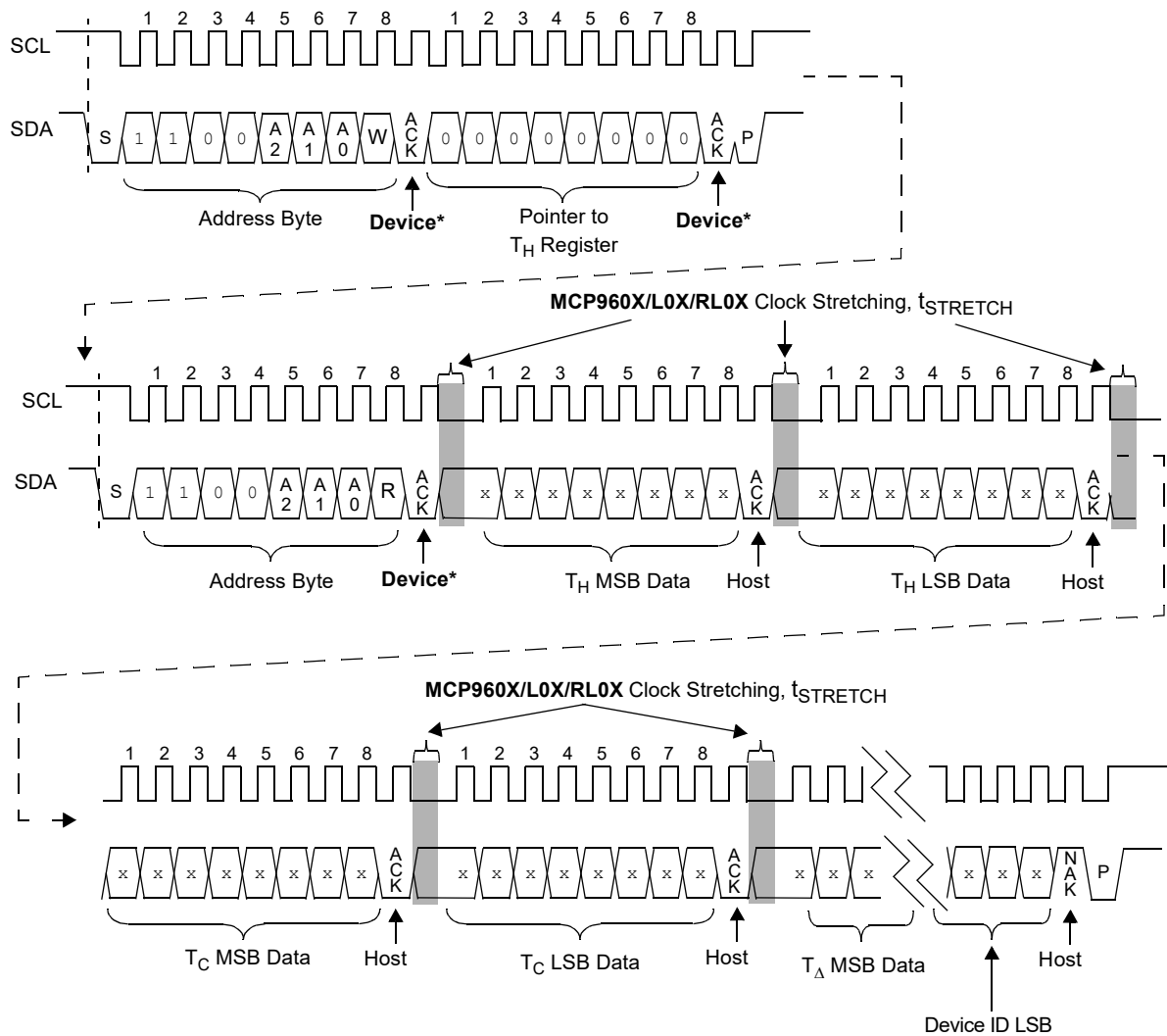

FIGURE 4-5: Timing Diagram to Set a Register Pointer, Write Two Bytes, and Read the Data.



Note: this is an example pseudo routine:

```

i2c_start(); // send START command
i2c_write(b'1100 0000'); // WRITE Command
// also, make sure bit 0 is cleared '0'
i2c_write(b'0000 0000'); // Write TH register to set the starting register for sequential read
i2c_stop(); // send STOP command
i2c_start(); // send START command
i2c_write(b'1100 0001'); // READ Command
// also, make sure bit 0 is set '1'
for (i=0; i<29, i++){
    Data_Buffer[i] = i2c_read(ACK); // READ 8 bits (with tSTRETCH delay)
    // and Send ACK bit
}
Data_Buffer[i] = i2c_read(NAK); // READ 8 bits (with tSTRETCH delay)
// and Send NAK bit
i2c_stop(); // send STOP command
    
```

***MCP960X/L0X/RL0X**

FIGURE 4-6: Timing Diagram to Sequential Read All Registers Starting from TH Register.

5.0 FUNCTIONAL DESCRIPTION

The MCP960X/L0X/RL0X Thermocouple temperature converter consists of an 18-bit Delta-Sigma Analog-to-Digital Converter (ADC), which is used to measure the thermocouple voltage or EMF, a digital

temperature sensor used to measure cold-junction or ambient temperature and a processor core which is used to compute the EMF to degree Celsius conversion using coefficients derived from the NIST ITS-90 coefficients. Figure 5-1 shows a block diagram of how these functions are structured in the device.

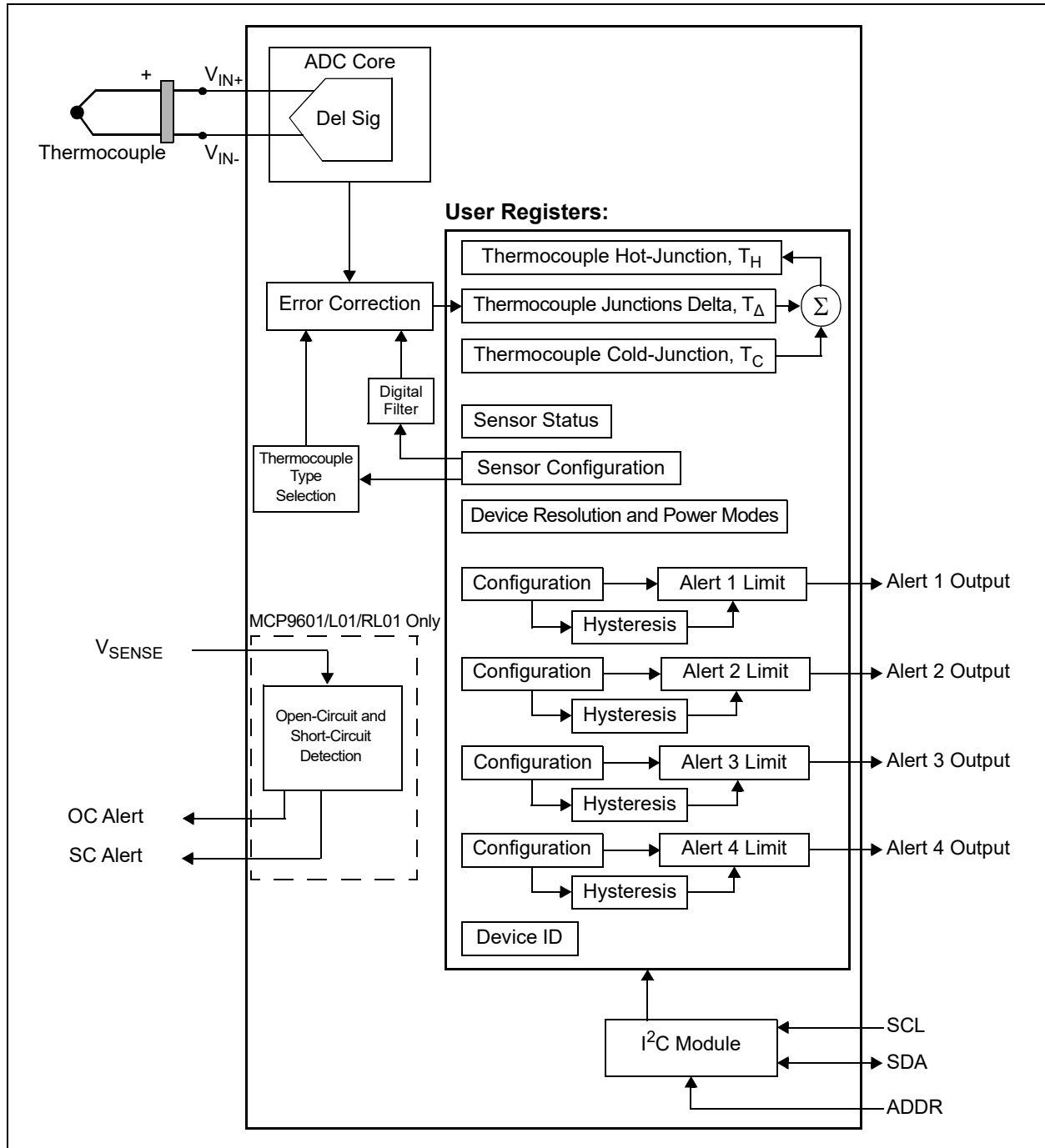

FIGURE 5-1: Functional Block Diagram.

MCP960X/L0X/RL0X

The MCP960X/L0X/RL0X device has several registers that are user-accessible. These registers include the Thermocouple Temperature (cold-junction compensated), Hot-Junction Temperature, Cold-Junction Temperature, Raw ADC Data, user-programmable Alert Limit registers, and STATUS and Configuration registers.

The Temperature and the Raw ADC Data registers are read-only registers, used to access the thermocouple and the ambient temperature data. In addition, the four Alert Temperature registers are individually controlled, and can be used to detect a rising and/or a falling temperature change. If the ambient temperature drifts beyond the user-specified limits, the MCP960X/L0X/RL0X device outputs an alert flag at the corresponding pin (refer to [Section 5.3.3 “Alert Configuration Registers”](#)). The alert limits can also be used to detect critical temperature events.

The MCP960X/L0X/RL0X also provides STATUS and Configuration registers, which allow users to detect device statuses. The Configuration registers provide various features, such as adjustable temperature measurement resolution and Shutdown modes. The thermocouple types can also be selected using the Configuration registers.

The registers are accessed by sending a Register Pointer to the MCP960X/L0X/RL0X using the serial interface. This is an 8-bit write-only pointer. [Register 5-1](#) describes the pointer definitions.

REGISTER 5-1: REGISTER POINTER

U-0	U-0	W-0	W-0	W-0	W-0	W-0	W-0
—	—	P[5:0]					
bit 7							bit 0

Legend:

R = Readable bit

W = Writable bit

U = Unimplemented bit, read as '0'

-n = Value at POR

'1' = Bit is set

'0' = Bit is cleared

x = Bit is unknown

bit 7-6

Unimplemented: Read as '0'

bit 5-0

P[5:0]: Pointer bits

- 0000 0000 = Thermocouple Hot-Junction register, T_H
- 0000 0001 = Junctions Temperature Delta register, T_{Δ}
- 0000 0010 = Cold-Junction Temperature register, T_C
- 0000 0011 = Raw ADC Data register
- 0000 0100 = STATUS register
- 0000 0101 = Thermocouple Sensor Configuration register
- 0000 0110 = Device Configuration register
- 0000 1000 = Alert 1 Configuration register
- 0000 1001 = Alert 2 Configuration register
- 0000 1010 = Alert 3 Configuration register
- 0000 1011 = Alert 4 Configuration register
- 0000 1100 = Alert 1 Hysteresis register, T_{HYST1}
- 0000 1101 = Alert 2 Hysteresis register, T_{HYST2}
- 0000 1110 = Alert 3 Hysteresis register, T_{HYST3}
- 0000 1111 = Alert 4 Hysteresis register, T_{HYST4}
- 0001 0000 = Temperature Alert 1 Limit register, T_{ALERT1}
- 0001 0001 = Temperature Alert 2 Limit register, T_{ALERT2}
- 0001 0010 = Temperature Alert 3 Limit register, T_{ALERT3}
- 0001 0011 = Temperature Alert 4 Limit register, T_{ALERT4}
- 0010 0000 = Device ID/Revision register

MCP960X/L0X/RL0X

TABLE 5-1: SUMMARY OF REGISTERS AND BIT ASSIGNMENTS

Register	Pointer	bit 7	bit 6	bit 5	bit 4	bit 3	bit 2	bit 1	bit 0
Hot-Junction Temperature – T _H	00000000	SIGN	1024°C	512°C	256°C	128°C	64°C	32°C	16°C
		8°C	4°C	2°C	1°C	0.5°C	0.25°C	0.125°C	0.0625°C
Junctions Temperature Delta – T _Δ	00000001	SIGN	1024°C	512°C	256°C	128°C	64°C	32°C	16°C
		8°C	4°C	2°C	1°C	0.5°C	0.25°C	0.125°C	0.0625°C
Cold-Junction Temperature – T _C	00000010	SIGN				128°C	64°C	32°C	16°C
		8°C	4°C	2°C	1°C	0.5°C	0.25°C	0.125°C	0.0625°C
Raw Data ADC	00000011	SIGN						bit 17	bit 16
		bit 15	—	—	—	—	—	—	bit 8
		bit 7	—	—	—	—	—	—	bit 0
STATUS MCP9600/L00/RL00	00000100	Burst Complete	T _H Update	—	Input Range	Alert 4 Status	Alert 3 Status	Alert 2 Status	Alert 1 Status
STATUS MCP9601/L01/RL01				Short-Circuit (SC)	Open-Circuit (OC)/Input Range				
Thermocouple Sensor Configuration	00000101	—	Thermocouple Type Select Type K, J, T, N, S, E, B, R			—	Filter Coefficients		
Device Configuration	00000110	Cold-Junc. Resolution	ADC Resolution		Burst Mode Temperature Samples			Shutdown Modes	
			Unimplemented bits, Read as '0'						
Alert 1 Configuration	00001000	Interrupt Clear	—	—	Monitor T _H or T _C	Detect Rising or Falling Temps	Active- High or Active-Low Output	Comparator or Interrupt Mode	Enable Alert Output
Alert 2 Configuration	00001001								
Alert 3 Configuration	00001010								
Alert 4 Configuration	00001011								
Alert 1 Hysteresis	00001100	128°C	64°C	32°C	16°C	8°C	4°C	2°C	1°C
Alert 2 Hysteresis	00001101								
Alert 3 Hysteresis	00001110								
Alert 4 Hysteresis	00001111								
Alert 1 Limit	00010000	SIGN	1024°C	512°C	256°C	128°C	64°C	32°C	16°C
		8°C	4°C	2°C	1°C	0.5°C	0.25°C	—	—
Alert 2 Limit	00010001	SIGN	1024°C	512°C	256°C	128°C	64°C	32°C	16°C
		8°C	4°C	2°C	1°C	0.5°C	0.25°C	—	—
Alert 3 Limit	00010010	SIGN	1024°C	512°C	256°C	128°C	64°C	32°C	16°C
		8°C	4°C	2°C	1°C	0.5°C	0.25°C	—	—
Alert 4 Limit	00010011	SIGN	1024°C	512°C	256°C	128°C	64°C	32°C	16°C
		8°C	4°C	2°C	1°C	0.5°C	0.25°C	—	—
Device ID/Revision MCP9600/L00/RL00	00100000	0	1	0	0	0	0	0	0
		Revision-Major				Revision-Minor			
Device ID/Revision MCP9601/L01/RL01	00100000	0	1	0	0	0	0	0	1
		Revision-Major				Revision-Minor			

5.1 Thermocouple Temperature Sensor Registers

This device integrates three Temperature registers that are used to read the cold and hot-junction temperatures, and the sum of the two junctions to output the absolute thermocouple temperature. In addition, the Raw ADC Data register, which is used to derive the thermocouple temperature, is available. The following sections describe each register in detail.

5.1.1 THERMOCOUPLE TEMPERATURE REGISTER (T_H)

This register contains the cold-junction compensated and error-corrected thermocouple temperature in degree Celsius. The temperature data from this register is the absolute Thermocouple Hot-Junction temperature, T_H, to the specified accuracy (see [Section 1.0 “Electrical Characteristics”](#)). T_H is the sum of the values in the T_Δ and T_C registers, as shown in [Figure 5-2](#).

The temperature bits are in two’s complement format; therefore, positive temperature data and negative temperature data are computed differently. [Equation 5-1](#) shows how to convert the binary data to temperature in degree Celsius.

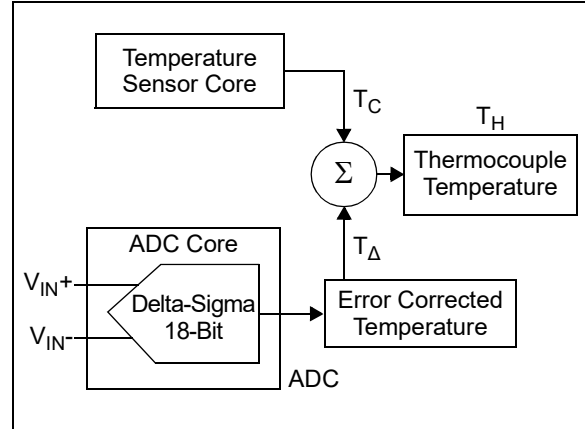

FIGURE 5-2: Thermocouple Temperature Register Block Diagram.

EQUATION 5-1: TEMPERATURE CONVERSION

Temperature ≥ 0°C $T_H = (UpperByte \times 16 + LowerByte/16)$
Temperature < 0°C $T_H = (UpperByte \times 16 + LowerByte/16) - 4096$

REGISTER 5-2: THERMOCOUPLE TEMPERATURE REGISTER - T_H (READ-ONLY)

R-0	R-0	R-0	R-0	R-0	R-0	R-0	R-0
SIGN	1024°C	512°C	256°C	128°C	64°C	32°C	16°C
bit 15							bit 8

R-0	R-0	R-0	R-0	R-0	R-0	R-0	R-0
8°C	4°C	2°C	1°C	0.5°C	0.25°C	0.125°C	0.0625°C
bit 7							bit 0

Legend:			
R = Readable bit	W = Writable bit	U = Unimplemented bit, read as '0'	
-n = Value at POR	'1' = Bit is set	'0' = Bit is cleared	x = Bit is unknown

bit 15-0 **T_H**: Data in Two’s Complement Format. Bit 15 is the sign bit and it is set when the temperature data is less than 0°C.
 This register contains the error corrected and cold-junction compensated thermocouple temperature.

5.1.2 THERMOCOUPLE JUNCTIONS DELTA TEMPERATURE REGISTER (T_{Δ})

This register contains the error corrected Thermocouple Hot-Junction temperature without the Cold-Junction compensation. The error correction methodology uses several coefficients to convert the digitized Thermocouple EMF voltage to degree Celsius. Each Thermocouple type has a unique set of coefficients as specified by NIST, and these coefficients are available in the configuration register for user selection as shown in [Figure 5-3](#).

EQUATION 5-2: TEMPERATURE CONVERSION

Temperature $\geq 0^{\circ}\text{C}$

$$T_{\Delta} = (\text{UpperByte} \times 16 + \text{LowerByte} / 16)$$

Temperature $< 0^{\circ}\text{C}$

$$T_{\Delta} = (\text{UpperByte} \times 16 + \text{LowerByte} / 16) - 4096$$

The temperature bits are in two's complement format, therefore, positive temperature data and negative temperature data are computed differently, as shown in [Equation 5-2](#).

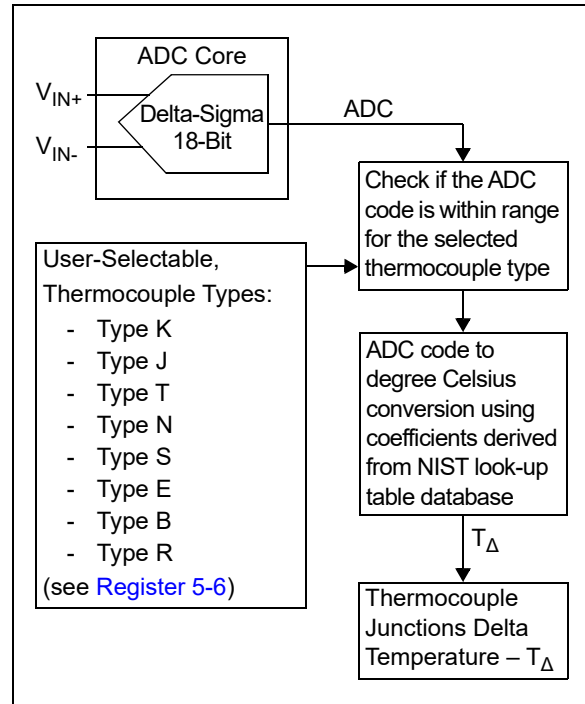

FIGURE 5-3: Thermocouple Hot-Junction Register (T_{Δ}) Block Diagram.

REGISTER 5-3: HOT-JUNCTION TEMPERATURE REGISTER - T_{Δ} (READ-ONLY)

R-0	R-0	R-0	R-0	R-0	R-0	R-0	R-0
SIGN	1024°C	512°C	256°C	128°C	64°C	32°C	16°C
bit 15							bit 8

R-0	R-0	R-0	R-0	R-0	R-0	R-0	R-0
8°C	4°C	2°C	1°C	0.5°C	0.25°C	0.125°C	0.0625°C
bit 7							bit 0

Legend:

R = Readable bit
-n = Value at POR

W = Writable bit
'1' = Bit is set

U = Unimplemented bit, read as '0'
'0' = Bit is cleared
x = Bit is unknown

bit 15-0 T_{Δ} : Data in Two's Complement Format. Bit 15 is the sign bit and it is set when the temperature data is less than 0°C .

This register contains Thermocouple Hot-Junction temperature data without the cold-junction compensation.

5.1.3 COLD-JUNCTION/AMBIENT TEMPERATURE REGISTER (T_C)

The MCP960X/L0X/RL0X integrates an ambient temperature sensor which can be used to measure the thermocouple cold-junction temperature. For accurate measurement, the device will have to be placed at close proximity to the thermocouple cold-junction to detect the junction ambient temperature. This is a 16-bit double-buffered, read-only register. The temperature resolution is user-selectable to 0.0625°C/LSb or 0.25°C/LSb resolutions and setting the resolution determines the temperature update rate, as shown in [Table 5-2](#).

EQUATION 5-3: TEMPERATURE CONVERSION

Temperature ≥ 0°C $T_C = (UpperByte \times 16 + LowerByte/16)$
Temperature < 0°C $T_C = (UpperByte \times 16 + LowerByte/16) - 4096$

The temperature bits are in two's complement format; therefore, positive temperature data and negative temperature data are computed differently, as shown in [Equation 5-3](#).

TABLE 5-2: RESOLUTION vs. CONVERSION TIME

Resolution	Conversion Time (typical)	Register Bits (Note 1)
0.0625°C	250 ms	s s s s x x x x x x x x x x x x
0.25°C	63 ms	s s s s x x x x x x x x x x 0 0

Note 1: 's' is Sign and 'x' is unknown bit.

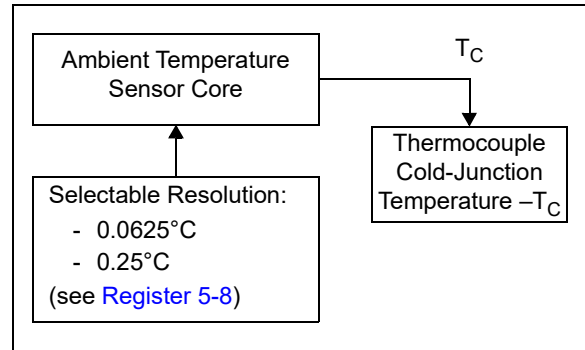

FIGURE 5-4: Thermocouple Cold-Junction Register (T_C) Block Diagram.

REGISTER 5-4: COLD-JUNCTION TEMPERATURE REGISTER - T_C (READ ONLY)

R-0	R-0	R-0	R-0	R-0	R-0	R-0	R-0
SIGN				128°C	64°C	32°C	16°C
bit 15				bit 8			

R-0	R-0	R-0	R-0	R-0	R-0	R-0	R-0
8°C	4°C	2°C	1°C	0.5°C	0.25°C	0.125°C	0.0625°C
bit 7				bit 0			

Legend:		
R = Readable bit	W = Writable bit	U = Unimplemented bit, read as '0'
-n = Value at POR	'1' = Bit is set	'0' = Bit is cleared x = Bit is unknown

bit 15-0 **T_C:** Data in Two's Complement Format. Bits 15-12 are sign bits and the bits are set when the temperature data is less than 0°C.
 This register contains the thermocouple cold-junction temperature or the device ambient temperature data. Bits 1 and 0 may remain clear ('0') depending on the status of the Resolution setting, bit 7 of Register 5-8.

5.1.4 ANALOG-TO-DIGITAL CONVERTER (ADC)

The MCP960X/L0X/RL0X uses an 18-bit Delta-Sigma Analog-to-Digital Converter to digitize the Thermocouple EMF voltage and the data is available in the ADC register. The ADC measurement resolution is selectable, which enables the user to choose faster conversion times with reduced resolution. This feature is useful to detect fast transient temperatures.

TABLE 5-3: ADC RESOLUTION⁽³²⁾

Resolution/ Sensitivity (typical)	Conversion Time (typical)	Raw ADC Register Bit Format (Note 1)
18-bit/2 μ V	320 ms	ssss sssx xxxx xxxx xxxx xxxx
16-bit/8 μ V	80 ms	ssss sssx xxxx xxxx xxxx xx00
14-bit/32 μ V	20 ms	ssss sssx xxxx xxxx xxxx 0000
12-bit/128 μ V	5 ms	ssss sssx xxxx xxxx xx00 0000

Note 1: 's' is the Sign bit and 'x' is the ADC data bit.

2: See [Section 6.2.2 "Conversion Time vs. Self-Heat"](#).

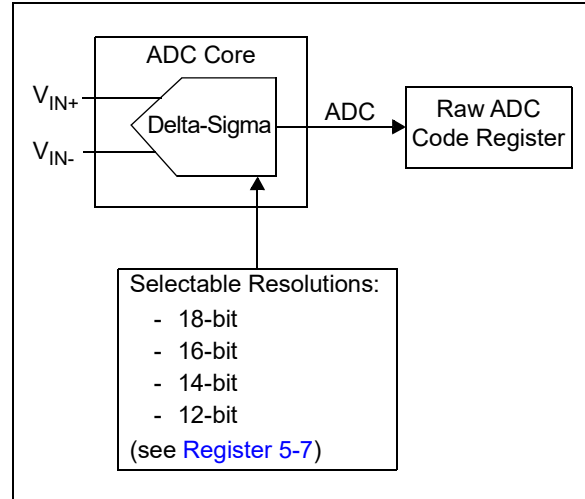

FIGURE 5-5: Delta-Sigma Analog-to-Digital Converter, ADC Core Block Diagram.

REGISTER 5-5: 24-BIT ADC REGISTER (READ-ONLY)

R-0	R-0	R-0	R-0	R-0	R-0	R-0	R-0
SIGN						ADC Data	
bit 23						bit 16	
R-0	R-0	R-0	R-0	R-0	R-0	R-0	R-0
ADC Data							
bit 15						bit 8	
R-0	R-0	R-0	R-0	R-0	R-0	R-0	R-0
ADC Data							
bit 7						bit 0	

Legend:

R = Readable bit	W = Writable bit	U = Unimplemented bit, read as '0'
-n = Value at POR	'1' = Bit is set	'0' = Bit is cleared
		x = Bit is unknown

bit 23-0 **ADC Data:** Raw ADC data in Two's Complement Format. Bits 23-18 are sign bits and the bits are set when the ADC data is less than 0 micro-volt.

5.2 Sensor STATUS and Configuration Registers

This device provides various temperature and measurement Status bits which can be monitored regularly by the host controller. In addition, this device integrates various user-programmable features which can be useful to develop complex thermal management applications. The following sections describe each feature in detail.

5.2.1 STATUS REGISTER

The STATUS register contains several flag bits that indicate statuses, such as temperature alert, the ADC input range status for the selected thermocouple type and the Temperature register update status for both single conversion or Burst mode conversions.

REGISTER 5-6: STATUS REGISTER

R/W-0	R/W-0	U-0	R-0	R-0	R-0	R-0	R-0
Burst Complete	T _H Update	—	Input Range	Alert 4 Status	Alert 3 Status	Alert 2 Status	Alert 1 Status
		Short-Circuit (SC) ⁽¹⁾	Open-Circuit (OC)/Input Range ⁽¹⁾				
bit 7							bit 0

Legend:

R = Readable bit	W = Writable bit	U = Unimplemented bit, read as '0'
-n = Value at POR	'1' = Bit is set	'0' = Bit is cleared x = Bit is unknown

bit 7 **Burst Complete:** Burst Mode Conversions Status Flag bit

1 = T_Δ register Burst mode conversions complete
0 = Writing '0' has no effect

Once Burst mode is enabled, this bit is normally set after the first burst is complete. User can clear it and poll the bit periodically until the next burst of temperature conversions is complete (see [Register 5-8](#)).

bit 6 **T_H Update:** Temperature Update Flag bit

1 = Temperature conversion complete
0 = Writing '0' has no effect

This bit is normally set. User can clear it and poll the bit until the next temperature conversion is complete.

bit 5 **Unimplemented:** Read as '0' for the MCP9600/L00/RL00 only.

Short-Circuit (SC): Short-Circuit Detection bit for the MCP9601/L01/RL01 only (read-only)

1 = Thermocouple Shorted to V_{DD} or V_{SS}
0 = Normal operation

The V_{SENSE} pin must be connected to the Thermocouple as indicated in [Figure 1-1](#), using R_A and R_B resistors.

Note 1: MCP9601/L01/RL01 only.

REGISTER 5-6: STATUS REGISTER (CONTINUED)

- bit 4 **Input Range:** Temperature Range Detection bit (read-only)
- 1 = The ADC input Voltage (EMF) or the temperature data from the T_H register exceeds the measurement range for the selected thermocouple type
 - 0 = The ADC input Voltage (EMF) or the temperature data from the T_H register is within the measurement range for the selected thermocouple type
- If this bit is set, then the MCP9600/L00/RL00 input voltage (EMF) to Degree Celsius conversion may be bypassed under these conditions:
- If the thermocouple EMF exceeds the specified range, then the T_H and T_{Δ} registers are not updated, but the T_C register is updated with valid temperature data at the specified interval, or t_{CONV} .
 - If the thermocouple EMF is within the specified range, but the sum with the Cold-Junction EMF exceeds the specified range, then the T_H register is not updated, but the T_{Δ} and T_C registers are updated with valid temperature data at the specified interval, or t_{CONV} . In this case, the value of the T_{Δ} and T_C registers can be used to calculate valid Hot-Junction Temperature data using the NIST ITS-90 conversion look-up table or polynomial equation.
 - To identify date code for devices with this feature, refer to “MCP9600 Rev. A Silicon Errata and Data Sheet Clarification”, DS80000741.
- For the MCP9601/L01/RL01, this bit indicates whether the Thermocouple is disconnected from the inputs. The V_{SENSE} pin must be connected to the Thermocouple as indicated in [Figure 1-1](#), using R_A and R_B resistors. When the Thermocouple is disconnected, the voltage at the inputs exceeds the voltage range for the selected Thermocouple due to the R_A and R_B resistors.
- bit 3 **Alert 4:** Status bit (read-only)
- 1 = $T_X > T_{ALERT4}$
 - 0 = $T_X \leq T_{ALERT4}$
- Where: T_X is either T_H or T_C (user-selectable, see [Register 5-10](#)).
- bit 2 **Alert 3:** Status bit (read-only)
- 1 = $T_X > T_{ALERT3}$
 - 0 = $T_X \leq T_{ALERT3}$
- Where: T_X is either T_H or T_C (user-selectable, see [Register 5-10](#)).
- bit 1 **Alert 2:** Status bit (read-only)
- 1 = $T_X > T_{ALERT2}$
 - 0 = $T_X \leq T_{ALERT2}$
- Where: T_X is either T_H or T_C (user-selectable, see [Register 5-10](#)).
- bit 0 **Alert 1:** Status bit (read-only)
- 1 = $T_X > T_{ALERT1}$
 - 0 = $T_X \leq T_{ALERT1}$
- Where: T_X is either T_H or T_C (user-selectable, see [Register 5-10](#)).

Note 1: MCP9601/L01/RL01 only.

5.2.2 THERMOCOUPLE SENSOR CONFIGURATION REGISTER

The MCP960X/L0X/RL0X Sensor Configuration register is used to select the thermocouple sensor types and to select the digital filter options. This device supports eight thermocouple types. Each type has a unique set of error correction coefficients that are derived from the NIST Thermocouple EMF Voltage Conversion database.

In addition, this device integrates a first order, recursive Infinite Impulse Response (IIR) filter, also known as Exponential Moving Average (EMA). The filter uses the current new temperature sample and the previous filter output to calculate the next filter output. It also adds more weight to the current temperature data, allowing a faster filter response to the immediate change in temperature. This feature can be used to filter out fast thermal transients or thermal instability at the thermocouple hot-junction temperature. Writing this register resets the filter.

The filter equation is shown in Equation 5-4 and the Filter Coefficient n is user-selectable, from Level 0 to 7. A coefficient of 0 disables the filter function and a 7 coefficient provides a maximum digital filter. Figure 5-6 shows the filter response to a step function, which can be used to extrapolate the filter performance to various temperature changes.

EQUATION 5-4: DIGITAL FILTER

$$Y = k \times X + (1 - k) \times Y_{-1}$$

$$k = 2 / (2^n + 1)$$

Where:

- Y = New filtered temperature in T_{Δ}
- X = Current, unfiltered hot-junction temperatures
- Y_{-1} = Previous filtered temperature
- n = User-selectable filter coefficient

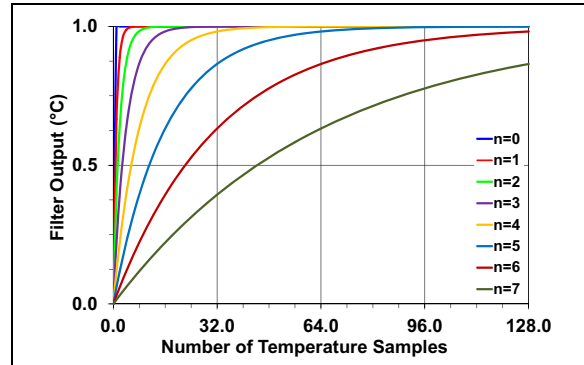

FIGURE 5-6: Filter Step Response.

REGISTER 5-7: SENSOR CONFIGURATION REGISTER

U-0	R/W-0	R/W-0	R/W-0	U-0	R/W-0	R/W-0	R/W-0
—	Thermocouple Type Select, Type K, J, T, N, S, E, B, R			—	Filter Coefficients		
bit 7				bit 0			

Legend:

R = Readable bit W = Writable bit U = Unimplemented bit, read as '0'
 -n = Value at POR '1' = Bit is set '0' = Bit is cleared x = Bit is unknown

- bit 7 **Unimplemented:** Read as '0'
- bit 6-4 **Thermocouple Type:** Thermocouple Type Select bits
 - 000 = Type K
 - 001 = Type J
 - 010 = Type T
 - 011 = Type N
 - 100 = Type S
 - 101 = Type E
 - 110 = Type B
 - 111 = Type R
- bit 3 **Unimplemented:** Read as '0'
- bit 2-0 **Filter Coefficient – n:** Filter Coefficient bits
 - 000 = n = 0: Filter off
 - 001 = n = 1: Minimum filter
 - 010 = n = 2
 - 011 = n = 3
 - 100 = n = 4: Mid filter
 - 101 = n = 5
 - 110 = n = 6
 - 111 = n = 7: Maximum filter

5.2.3 DEVICE CONFIGURATION REGISTER

The device Configuration register allows the user to configure various functions, such as sensor measurement resolutions and Power modes. The Resolution register is used to select the sensor resolution for the desired temperature conversion time. When resolutions are changed, the change takes effect when the next measurement cycle begins.

This device integrates two Low-Power Operating modes: Shutdown mode and Burst mode, which can be selected using bit 0 and bit 1. When the Shutdown mode is executed, all power consuming activities are disabled and the operating current remains at I_{SHDN} . During the Shutdown mode, all registers are accessible; however, I^2C activity on the bus increases the current.

The Burst mode enables users to execute a given number of temperature samples (defined by bits[4-2]) before entering Shutdown mode. Each temperature sample is compared to the user-settable alert temperature limits, and if the alert conditions are true, then the device asserts the corresponding alert output. In addition, if the filter option is enabled, then the filter engine is applied to each temperature sample. The alert thresholds are also compared to the filtered temperature data. This feature is useful for battery power applications, where temperature is sampled upon request from the host controller.

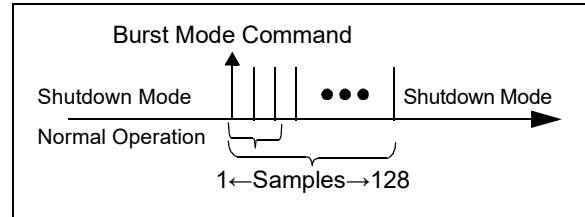

FIGURE 5-7: Burst Mode Operation.

REGISTER 5-8: DEVICE CONFIGURATION REGISTER

R/W-0	R/W-0	R/W-0	R/W-0	R/W-0	R/W-0	R/W-0	R/W-0
Cold-Junction Resolution	ADC Measurement Resolution		Burst Mode Temperature Samples		Shutdown Modes		
bit 7							bit 0

Legend:

R = Readable bit W = Writable bit U = Unimplemented bit, read as '0'
 -n = Value at POR '1' = Bit is set '0' = Bit is cleared x = Bit is unknown

- bit 7 **Cold-Junction/Ambient Sensor Resolution:** Cold-Junction Resolution bit (see [Table 5-2](#)):
 0 = 0.0625°C
 1 = 0.25°C
- bit 6-5 **ADC Measurement Resolution:** ADC Resolution bits (see [Table 5-3](#)):
 00 = 18-bit Resolution
 01 = 16-bit Resolution
 10 = 14-bit Resolution
 11 = 12-bit Resolution
- bit 4-2 **Burst Mode Temperature Samples:** Number of Temperature Samples bits
 000 = 1 sample
 001 = 2 samples
 010 = 4 samples
 011 = 8 samples
 100 = 16 samples
 101 = 32 samples
 110 = 64 samples
 111 = 128 samples
- bit 1-0 **Shutdown Modes:** Shutdown Mode bits
 00 = Normal operation
 01 = Shutdown mode
 10 = Burst mode
 11 = Unimplemented: this setting has no effect

5.3 Temperature Alert Registers

This device provides four Temperature Alert registers that are individually configured, which allow users to monitor multiple temperature zones with a single device. The following sections describe each alert feature in detail.

5.3.1 ALERT LIMIT REGISTERS

This device integrates four individually controlled Temperature Alert Limit registers. Each alert limit is individually set to detect a rising or falling temperature, or either the Thermocouple Temperature (T_H) register or the Cold-Junction (T_C) register. The corresponding alert limit outputs can also be enabled for temperature status indicators. All alert functions are configured using the Alert Limit Configuration registers (Register 5-11) and the alert output hysteresis function is set using the Alert Hysteresis registers (Register 5-10).

TABLE 5-4: ALERT LIMIT REGISTERS

Register	Register Pointer
Alert 1 Limit – T_{ALERT1}	0001 0000
Alert 2 Limit – T_{ALERT2}	0001 0001
Alert 3 Limit – T_{ALERT3}	0001 0010
Alert 4 Limit – T_{ALERT4}	0001 0011

REGISTER 5-9: ALERT LIMITS 1, 2, 3 AND 4 REGISTERS

R/W-0	R/W-0	R/W-0	R/W-0	R/W-0	R/W-0	R/W-0	R/W-0
SIGN	1024°C	512°C	255°C	128°C	64°C	32°C	16°C
bit 15							bit 8
R/W-0	R/W-0	R/W-0	R/W-0	R/W-0	R/W-0	U-0	U-0
8°C	4°C	2°C	1°C	0.5°C	0.25°C	—	—
bit 7							bit 0

Legend:

R = Readable bit W = Writable bit U = Unimplemented bit, read as '0'
 -n = Value at POR '1' = Bit is set '0' = Bit is cleared x = Bit is unknown

bit 15-0 **Alert 1, 2, 3 and 4:** Data in Two's Complement Format. Bit 15 is the sign bit and it is set when the temperature data is less than 0°C. Bits 1 and 0 are unimplemented, therefore, writing these bits has no effect.

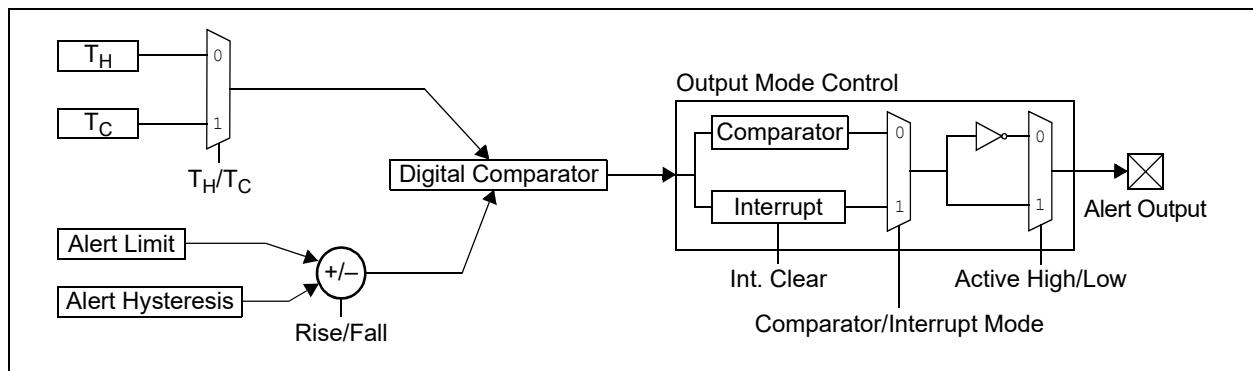

FIGURE 5-8: Alert Limits Set to Detect T_H and T_C .

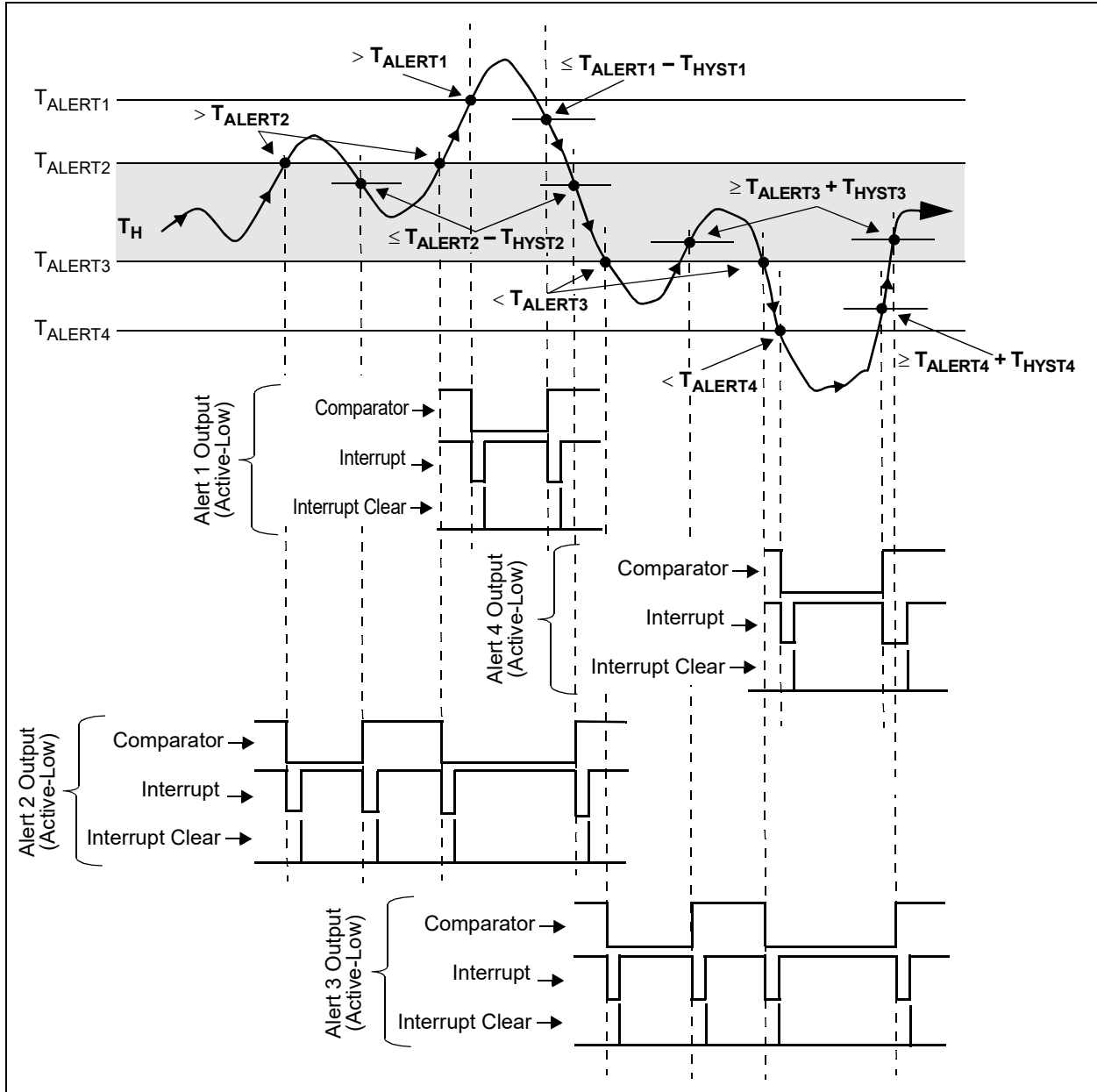

FIGURE 5-9: Alert Limits Boundary Conditions and Output Characteristics when Set to Detect T_H .

5.3.2 ALERT HYSTERESIS REGISTER

This device integrates four individually controlled temperature Alert Hysteresis registers for each alert output, with a range of 0°C to +255°C.

The alert hysteresis directions are set using bit 3 of the corresponding Alert Configuration registers (Register 5-10) to detect rising or falling temperatures. For rising temperatures, the hysteresis range is below the alert limit where, as for falling temperatures, the hysteresis range is above the alert limit, as shown in Figure 5-10.

TABLE 5-5: ALERT HYSTERESIS REGISTERS

Register	Register Pointer
Alert 1 Hysteresis – T_{HYST1}	0000 1100
Alert 2 Hysteresis – T_{HYST2}	0000 1101
Alert 3 Hysteresis – T_{HYST3}	0000 1110
Alert 4 Hysteresis – T_{HYST4}	0000 1111

REGISTER 5-10: T_{HYSTx} : ALERT 1, 2, 3 AND 4 HYSTERESIS REGISTERS

R/W-0	R/W-0	R/W-0	R/W-0	R/W-0	R/W-0	R/W-0	R/W-0
128°C	64°C	32°C	16°C	8°C	4°C	2°C	1°C
bit 7							bit 0

Legend:

R = Readable bit
-n = Value at POR

W = Writable bit
'1' = Bit is set

U = Unimplemented bit, read as '0'
'0' = Bit is cleared

x = Bit is unknown

bit 7-0 **Alert Hysteresis:** Alert Hysteresis Range 0x00 to 0xFF bits (which represents +1°C to +255°C)

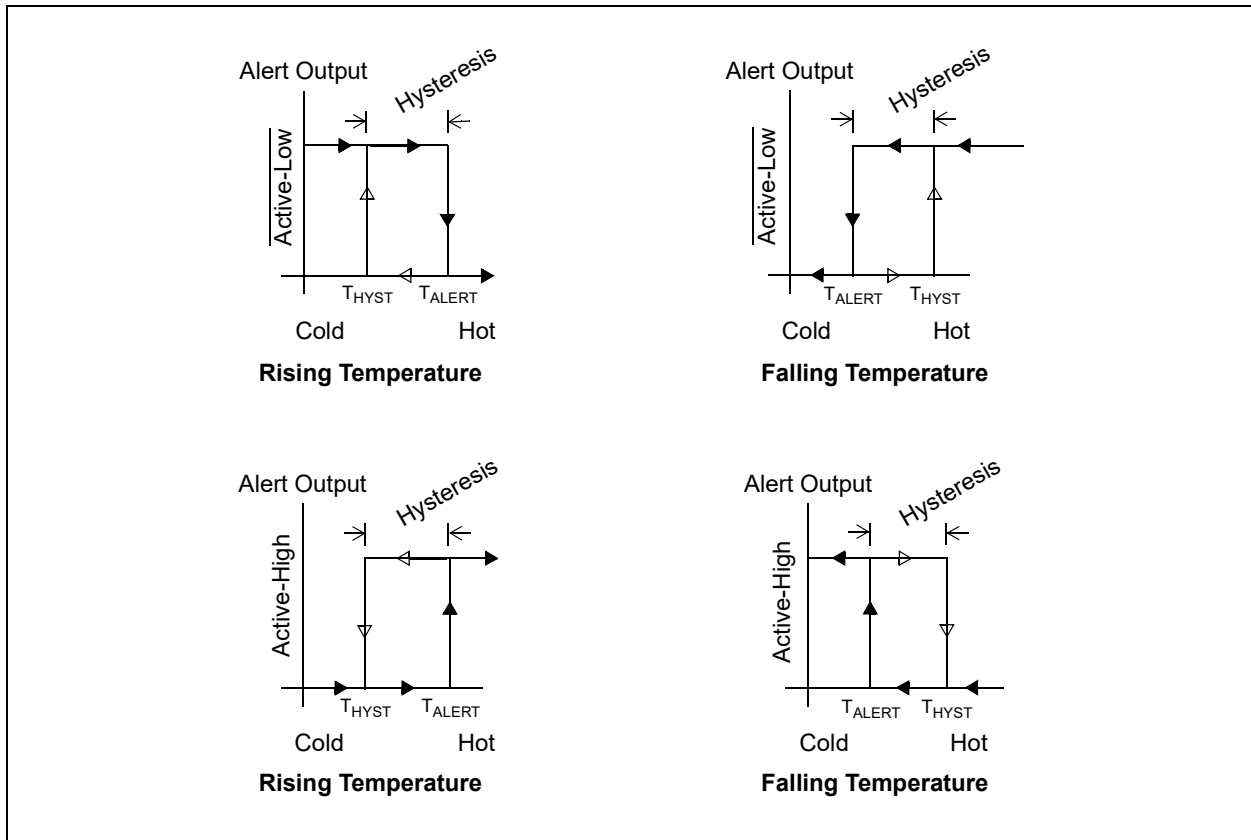

FIGURE 5-10: Graphical Description of Alert Output Hysteresis Direction.

5.3.3 ALERT CONFIGURATION REGISTERS

This device integrates four individually controlled temperature alert outputs. Each output is configured for the corresponding alert output using the Alert Output Configuration registers.

The Configuration registers are used to enable each output, select the Alert Function mode as Comparator or Interrupt mode, active-high or active-low output, detect rising or falling temperatures and detect T_H or T_C Temperature registers.

The Comparator mode is useful for thermostat-type applications, such as on/off switches for fan controllers, buzzer or LED indicators. The alert output asserts and deasserts when the temperature exceeds the user-specified limit, and the user-specified hysteresis limit. The Interrupt mode is useful for interrupt driven microcontroller-based systems. The alert outputs are asserted each time the temperature exceeds the user-specified alert limit and hysteresis limits.

The microcontroller will have Acknowledged the interrupt signal from the corresponding alert output by clearing the interrupt using bit 7 of the corresponding Configuration register.

The Rise/Fall bit (bit 3) and the Monitor T_H/T_C bit (bit 4) can be used to detect and maintain the thermocouple temperature or the cold-junction temperature to the desired temperature window.

TABLE 5-6: ALERT CONFIGURATION REGISTERS

Register	Register Pointer
Alert 1 Configuration	0000 1000
Alert 2 Configuration	0000 1001
Alert 3 Configuration	0000 1010
Alert 4 Configuration	0000 1011

REGISTER 5-11: ALERT 1, 2, 3 AND 4 CONFIGURATION REGISTER

R/W-0	U-0	U-0	R/W-0	R/W-0	R/W-0	R/W-0	R/W-0
Interrupt Clear	—	—	Monitor T_H/T_C	Rise/Fall	Active-High/Low	Comp./Int.	Alert Enable
bit 7							bit 0

Legend:

R = Readable bit W = Writable bit U = Unimplemented bit, read as '0'
 -n = Value at POR '1' = Bit is set '0' = Bit is cleared x = Bit is unknown

- bit 7 **Interrupt Clear:** Interrupt Clear bit
 1 = Clears Interrupt flag (forced '0' by device)
 0 = Normal state or cleared state
- bit 6-5 **Unimplemented:** Read as '0'
- bit 4 **Monitor T_H or T_C :** Temperature Maintain/Detect bit
 1 = Alert monitor for T_C cold-junction sensor
 0 = Alert monitor for T_H thermocouple temperature
- bit 3 **Rise/Fall:** Alert Temperature Direction bit
 1 = Alert limit for falling or cooling temperatures
 0 = Alert limit for rising or heating temperatures
- bit 2 **Active-High/Low:** Alert State bit
 1 = Active-high
 0 = Active-low
- bit 1 **Comp./Int.:** Alert Mode bit
 1 = Interrupt mode: Interrupt clears bit (bit 7) – must be set to deassert the alert output
 0 = Comparator mode
- bit 0 **Alert Enable:** Alert Output Enable bit
 1 = Alert output is enabled
 0 = Alert output is disabled

MCP960X/L0X/RL0X

5.3.4 DEVICE ID AND REVISION ID REGISTER

The Device ID (Identification) and Revision ID register is a 16-bit read-only register, which can be used to identify this device among other devices on the I²C bus. The upper 8 bits indicate the Device ID of 0x40 for the MCP9600/L00/RL00 and 0x41 for the MCP9601/L01/RL01 respectively, while the lower 8 bits indicate the device revision. The device revision byte is

divided into nibbles, where the upper nibble indicates the major revision and the lower nibble indicates minor revisions. The initial release is indicated by a major revision of '1' and a minor revision of '0' or 0x4010 for the MCP9600/L00/RL00 and 0x4110 for the MCP9601/L01/RL01. (Refer to "MCP9600 Silicon Errata and Data Sheet Clarification", DS80000741, for changes and revision IDs).

REGISTER 5-12: MCP9600/L00/RL00 DEVICE ID AND REVISION ID REGISTER

R-0	R-1	R-0	R-0	R-0	R-0	R-0	R-0
Device ID							
bit 15							
bit 8							

R-0	R-0	R-0	R-1	R-0	R-0	R-0	R-0
Revision-Major				Revision-Minor			
bit 7							
bit 0							

Legend:

R = Readable bit

W = Writable bit

U = Unimplemented bit, read as '0'

-n = Value at POR

'1' = Bit is set

'0' = Bit is cleared

x = Bit is unknown

bit 15-8 **Device ID:** Device ID bits (0x40)

bit 7-0 **Revision:** Major/Minor Revision ID bits (0x10) for the initial Release, or Revision 1.0 (Refer to the Silicon Errata, DS80000741, for change date codes and revision IDs).

REGISTER 5-13: MCP9601/L01/RL01 DEVICE ID AND REVISION ID REGISTER

R-0	R-1	R-0	R-0	R-0	R-0	R-0	R-1
Device ID							
bit 15							
bit 8							

R-0	R-0	R-0	R-1	R-0	R-0	R-0	R-0
Revision-Major				Revision-Minor			
bit 7							
bit 0							

Legend:

R = Readable bit

W = Writable bit

U = Unimplemented bit, read as '0'

-n = Value at POR

'1' = Bit is set

'0' = Bit is cleared

x = Bit is unknown

bit 15-8 **Device ID:** Device ID bits (0x41)

bit 7-0 **Revision:** Major/Minor Revision ID bits (0x10) for the initial Release, or Revision 1.0 (Refer to the Silicon Errata, DS80000741, for change date codes and revision IDs).

6.0 APPLICATION INFORMATION

6.1 Layout Considerations

The MCP960X/L0X/RL0X does not require any additional components to digitize thermocouples. However, it is recommended that a decoupling capacitor of 0.1 μF to 1 μF be used between the V_{DD} and GND pins. A high-frequency ceramic capacitor is recommended. It is necessary for the capacitor to be located as close as possible to the V_{DD} and ground pins of the device in order to provide effective noise protection.

In addition, good PCB layout is key for better thermal conduction from the PCB temperature to the sensor die. The PCB provides thermal conduction from the die to the thermocouple cold-junction; therefore, the component placement positioning and the copper layout techniques are key for optimum cold-junction compensation. The recommended implementation for optimum temperature sensitivity is to extend a copper ground pad around the device pins, as shown in Figure 6-1.

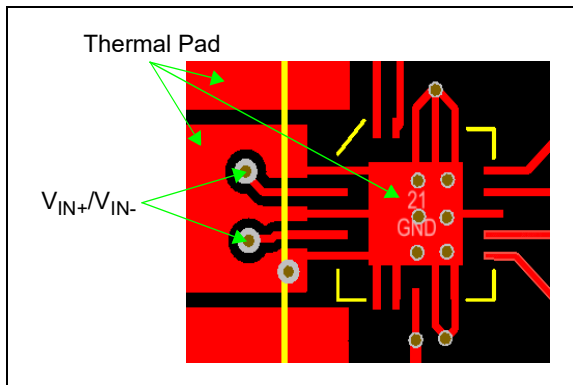

FIGURE 6-1: Recommended PCB Layout.

6.1.1 COLD-JUNCTION COMPENSATION

Copper provides better thermal conductivity than PCB FR4 to the ambient temperature. It also provides better thermal conduction than the 5 mm x 5 mm MQFN plastic package, which houses the temperature sensor die. Therefore, when connecting the thermocouple wire to the PCB, it is recommended to place the ground copper between the thermocouple connector footprint, where dissimilar conductive material is attached to the PCB and the MCP960X/L0X/RL0X exposed pad. This allows temperature to stabilize to the local ambient temperature (between the thermocouple connector junction and the PCB copper) and the copper trace conducts the temperature to the package exposed pad where the temperature sensor die is placed. The placement of the sensor exposed pad to the thermocouple connector junction greatly determines the temperature sensor's sensitivity to the local junction temperature changes. Figure 6-2 demonstrates the recommended techniques.

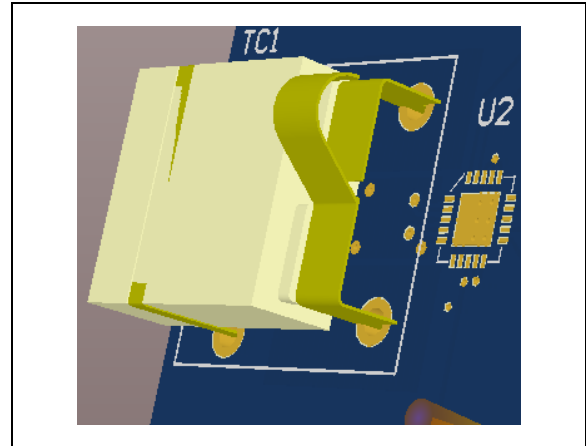

FIGURE 6-2: Recommended Component Placement.

6.2 Thermal Considerations

The potential for self-heating errors exist if the MCP960X/L0X/RL0X SDA, SCL and alert outputs are heavily loaded (high current) with pull-up resistors and circuits, such as high-current LEDs or buzzer loads. The temperature rise due to self-heat increases the ambient temperature sensor output, resulting in an increased temperature offset error compared to the thermocouple cold-junction ambient temperature.

6.2.1 SELF-HEAT DURING OPERATION

During normal operation, the typical self-heating error is negligible due to the relatively small current consumption of the MCP960X/L0X/RL0X. However, this device integrates a processor to compute the equations necessary to convert the thermocouple EMF voltage to degrees Celsius. The processor also maintains the I²C bus. During I²C communication, the device operating current increases to $I_{\text{DD}} = 1.5 \text{ mA}$ (typical), I²C Active specification. If the bus is continually polled for data at frequent intervals, then the processor power dissipates heat to the temperature sensor and the effect of self-heat can be detected. Therefore, the recommended implementation is to maintain polling to no more than three times per temperature conversion period of 320 ms or use the Burst mode feature to manage self-heat (refer to Section 6.2.3 “Using Burst Mode to Manage Self-Heat”). Equation 6-1 can also be used to determine the effect of self-heat.

EQUATION 6-1: EFFECT OF SELF-HEATING

$$T_{\Delta} = \theta_{JA}(V_{DD} \bullet I_{DD})$$

$$T_{\Delta} = \theta_{JC}(V_{DD} \bullet I_{DD})$$

$$T_{\Delta} = T_J - T_A$$

Where:

- T_J = Junction Temperature
- T_A = Ambient Temperature
- θ_{JA} = Package Thermal Resistance:
 - Junction to Ambient
- θ_{JC} = Package Thermal Resistance:
 - Junction to Case

At room temperature ($T_A = +25^{\circ}\text{C}$) with $I_{DD} = 2.5 \text{ mA}$ (maximum) and $V_{DD} = 3.3\text{V}$, the self-heating due to power dissipation, T_{Δ} , is 0.32°C for the MQFN package.

6.2.2 CONVERSION TIME vs. SELF-HEAT

Once the ADC completes digitization, the processor initiates the data computation routine for t_{CALC} , which also increases I_{DD} . During the 18-bit ADC conversion time (3 SPS, Samples per Second), the increased current lasts for approximately 5% of the one-second period. The effect of self-heat for the total power consumed per second, including the 5% t_{CALC} period, is negligible. However, as the ADC resolution is reduced from 18-bit to 16-bit, the power consuming t_{CALC} period increases to 20% per second. This change in resolution adds approximately 0.04°C (typical) temperature error due to self-heat. Table 6-1 provides an estimate for self-heat for all resolutions using Equation 6-1.

In order to reduce the effects of self-heat for lower resolution settings, the Burst mode feature is recommended to manage the effects of self-heat.

TABLE 6-1: ADC RESOLUTION vs. SELF-HEAT

Resolution	SPS (typ.)	t_{CALC} Duration per Second	T_{Δ}
18-bit	3	5%	0.0096°C
16-bit	15	20%	0.0384°C
14-bit	60	80%	0.1536°C
12-bit	240	100%	0.1920°C

Note: $V_{DD} = 3.3\text{V}$ and $I_{DD} = 1.5 \text{ mA}$ (typical).

6.2.3 USING BURST MODE TO MANAGE SELF-HEAT

The Burst mode feature is useful to manage power dissipation while maintaining the device sensitivity to changes in temperature (see Section 5.2.3 “Device Configuration Register”). While the device is in Low-Power or Shutdown mode, the host controller executes Burst mode to sample temperature. The number of temperature samples and the measurement resolution settings are selected while executing the command. While in Burst mode, if the temperature data exceeds the alert limits, the device asserts the corresponding alert output. The alert outputs are used so the host controller does not need to continually poll the latest temperature data and potentially increase the temperature error.

In addition, with some applications monitoring several hundred degrees of temperature changes, 18-bit resolution may not be necessary. In this case, a fewer number of burst samples reducing the resolution enables the user to monitor fast transient temperatures at the burst intervals. The 12-bit ADC resolution provides approximately 3°C resolution (for Type K) and a new sample of temperature data is computed at approximately 20 ms intervals. Therefore, the number of Burst mode Samples per Second can be selected to manage the effects of self-heat using these estimates.

The temperature conversion status during Burst mode can also be momentarily polled (using bit 7 of Register 5-6) to detect whether the on-going sample bursts are completed. The host controller may terminate an on-going burst by executing a shutdown command or resetting the Burst mode by sending another burst command.

6.2.4 ALERT OUTPUTS

The alert outputs are intended to drive high-impedance loads. Typically, the outputs are connected to a microcontroller input pin. However, if the outputs are used to drive indicators, such as LEDs or buzzers, then a buffer circuit is recommended in order to minimize the effects of self-heat due to the applied load (see Figure 6-3).

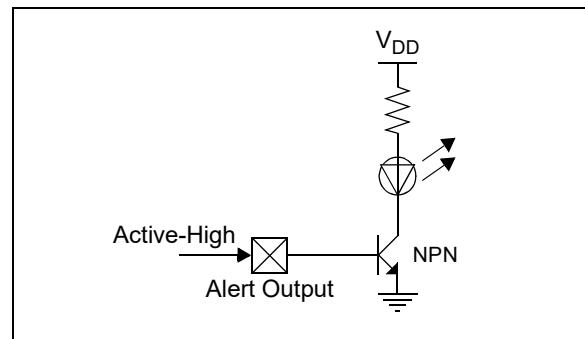

FIGURE 6-3: Alert Output Buffer for LED Indicator.

6.3 Device Features

6.3.1 I²C ADDRESSING

The MCP960X/L0X/RL0X supports up to eight devices on the I²C bus. Applications, such as large thermal management racks with several thermocouple sensor interfaces, are able to monitor various temperature zones with minimal pin count microcontrollers. This reduces the total solution cost, while providing a highly accurate thermal management solution using the MCP960X/L0X/RL0X.

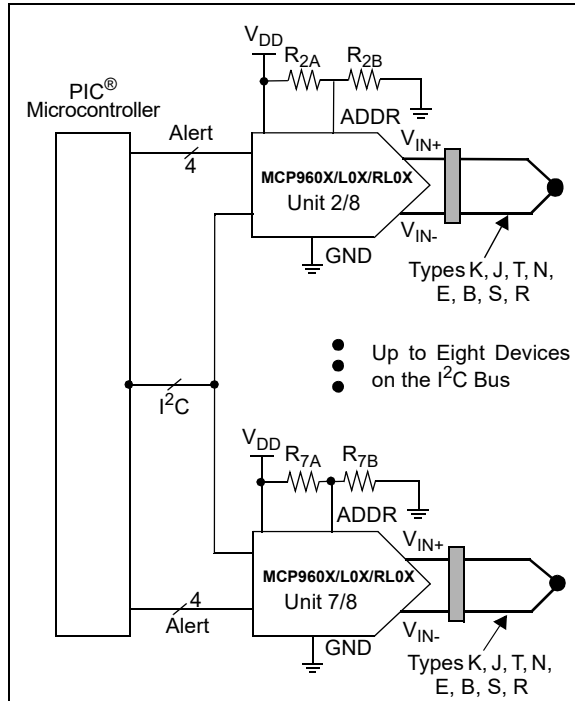

TABLE 6-2: RECOMMENDED RESISTOR VALUES FOR I²C ADDRESSING

Device #	Command Byte	Values	
		R _{XA} (kΩ)	R _{XB} (kΩ)
1	1100 000x	ADDR Pin Tied to GND	
2	1100 001x	R _{2A} = 10	R _{2B} = 2.2
3	1100 010x	R _{3A} = 10	R _{3B} = 4.3
4	1100 011x	R _{4A} = 10	R _{4B} = 7.5
5	1100 100x	R _{5A} = 10	R _{5B} = 13
6	1100 101x	R _{6A} = 10	R _{6B} = 22
7	1100 110x	R _{7A} = 10	R _{7B} = 43
8	1100 111x	ADDR Pin Tied to V _{DD}	

Note: Standard 5% tolerance resistors are used in the table; however, 1% tolerance resistors provide better ratio matching.

FIGURE 6-4: I²C Address Selection Implementation.

6.3.2 INPUT IMPEDANCE

The MCP960X/L0X/RL0X uses a switched capacitor amplifier input stage to gain the input signal to a maximum resolution of 2 μV/LSb at an 18-bit ADC setting. An internal input capacitor is used for charge storage. The differential input impedance, Z_{IN_DF}, is dominated by the sampling capacitor and the switched capacitor amplifier sampling frequency. During a sampling period, the charging and discharging of the sampling capacitor creates dynamic input currents at the input pins. Adding a 10-100 nF capacitor between the inputs can improve stability.

Since the sampling capacitor is only switching to the input pins during a conversion process, the input impedance is only valid during conversion periods. During Low-Power or Shutdown mode, the input amplifier stage is disabled; therefore, the input impedance is Z_{IN_CM}, which is due to the leakage current from ESD protection diodes, as shown in Figure 6-5.

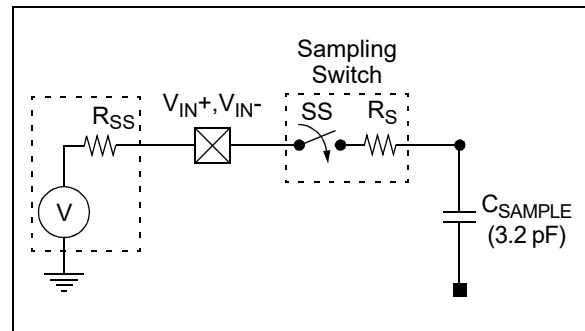

FIGURE 6-5: Thermocouple Input Stage.

6.3.3 OPEN AND SHORT DETECTION CIRCUITS

For the MCP9600/L00/RL00, external circuits can be added to detect the thermocouple status as open (physically disconnected) or as short (thermocouple wire in contact with the system ground or V_{DD}). If a passive circuit is added to the input stage, then the circuit loading effect to the MCP9600/L00/RL00 ADC inputs must be considered. System calibration is also required to ensure proper accuracy. In addition, external loads can degrade the device performance, such as input offset, gain and Integral Nonlinearity (INL) errors. If a low-impedance active circuit is added, then both offset and gain errors must be calibrated.

The MCP9601/L01/RL01 has a Thermocouple open and short-circuit detection mechanism, which is implemented using a Sense-Input pin (V_{SENSE}), as shown in Figure 1-1. The V_{SENSE} pin and R_A and R_B resistors must be connected as indicated in Figure 1-1. For proper operation, the resistor values must also be within the specified tolerance range. When open-circuit or short-circuit conditions are detected, the OC Alert and SC Alert Active-High Push-Pull outputs are asserted, respectively.

6.3.3.1 Open-Circuit Detection Technique

For MCP9600/L00/RL00 open-circuit detection, the Input Range bit (bit 4) of the STATUS register (Register 5-6), can be used to detect open-circuit conditions. This would require a few external resistors, as shown in Figure 6-6. The passive circuit does not affect the MCP9600/L00/RL00 accuracy. When the thermocouple is connected, the input Common-mode voltage is 50% of V_{DD} . When the thermocouple is disconnected, the voltage at the V_{IN+} input is 66% of V_{DD} and the voltage at the V_{IN-} input is pulled low to V_{SS} . This change forces the Input Range bit to be set.

The MCP9601/L01/RL01 open-circuit detection mechanism operates similarly (see Figure 6-7), and the detection thresholds are specified as V_{SiOC} and V_{SiNOR} (see DC Characteristics).

The host controller can momentarily poll the Status bit to detect the Open-Circuit condition. For the MCP9601/L01/RL01, the OC Alert pin can be used as hardware indicator.

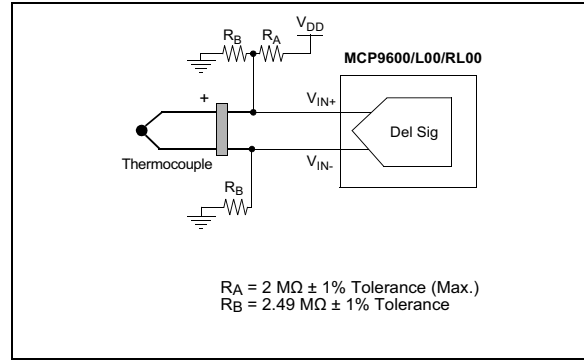

FIGURE 6-6: Adding Open-Circuit Detection Resistors (MCP9600/L00/RL00).

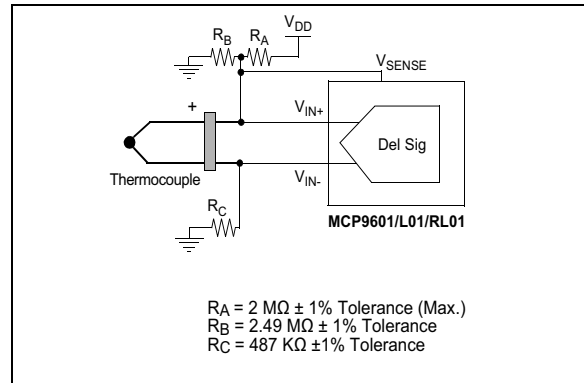

FIGURE 6-7: Adding Open-Circuit Detection Resistors (MCP9601/L01/RL01).

6.3.4 ALIASING AND ANTI-ALIASING FILTER

Aliasing occurs when the input signal contains time varying signals with frequency greater than half the sample rate. In the aliasing conditions, the ADC can output unexpected codes. The ADC integrates a first order sync filter; however, an external anti-aliasing filter can provide an added filter for high noise applications. This can be done with a simple RC low-pass filter at the inputs, as shown in Figure 6-8. Open-circuit detection resistors can also be added, as shown in Figure 6-9.

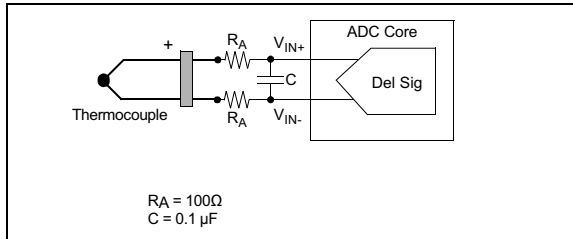

FIGURE 6-8: Adding a Low-Pass Filter.

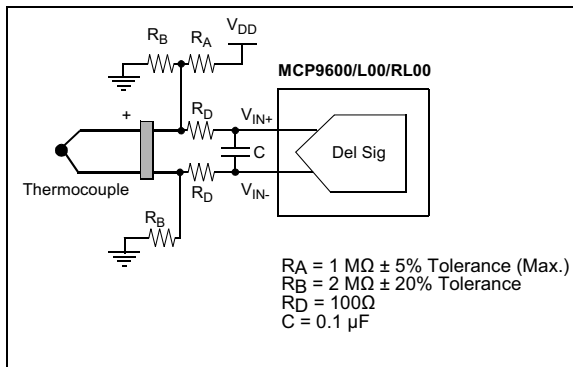

FIGURE 6-9: Adding Open-Circuit Detection Resistors with an Input Low-Pass Filter (MCP9600/L00/RL00, see Section 6.3.3 “Open and Short Detection Circuits”).

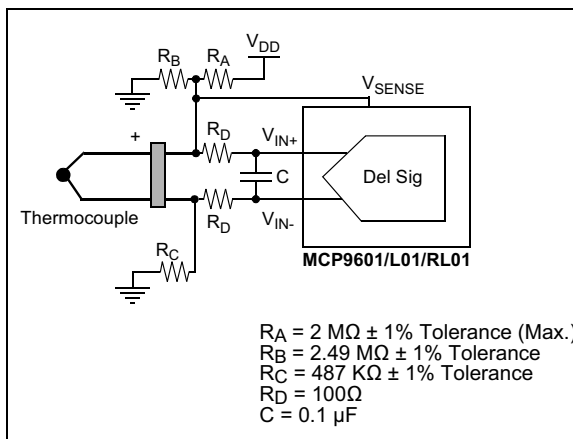

FIGURE 6-10: Adding Open-Circuit Detection Resistors with an Input Low-Pass Filter (MCP9601/L01/RL01).

6.3.5 ESD PROTECTION USING FERRITE BEADS

Ferrite beads and Transient Voltage Suppression (TVS) Diodes are highly recommended to protect the MCP960X/L0X/RL0X and other devices from a high frequency noise and ESD discharge through the thermocouple wire. These additional components can be added to the input channel as shown in Figure 6-11 and Figure 6-12.

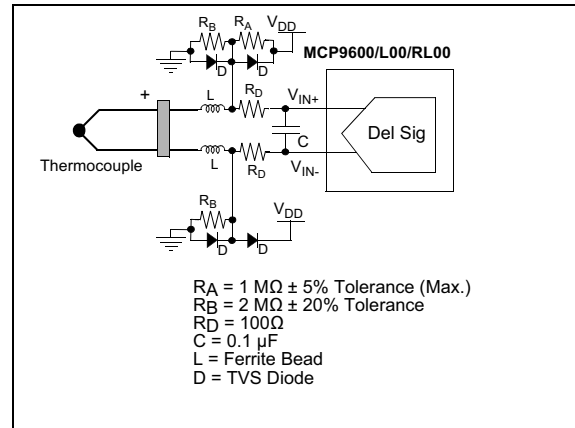

FIGURE 6-11: Adding Ferrite Beads (MCP9600/L00/RL00).

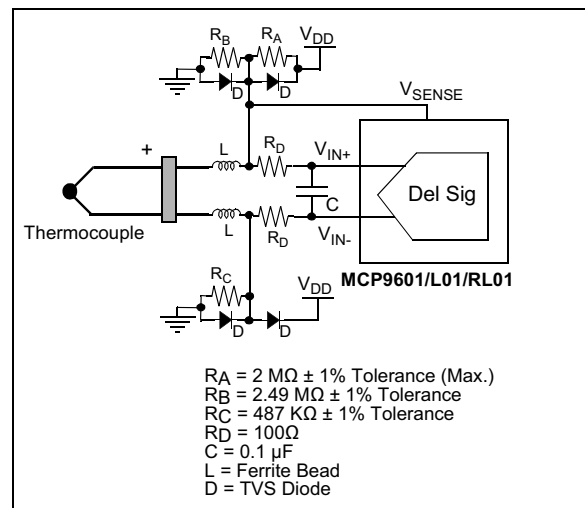

FIGURE 6-12: Adding Ferrite Beads (MCP9601/L01/RL01).

NOTES:

7.0 PACKAGING INFORMATION

7.1 Package Marking Information

20-Lead MQFN (5 × 5 × 1.0 mm)

Examples

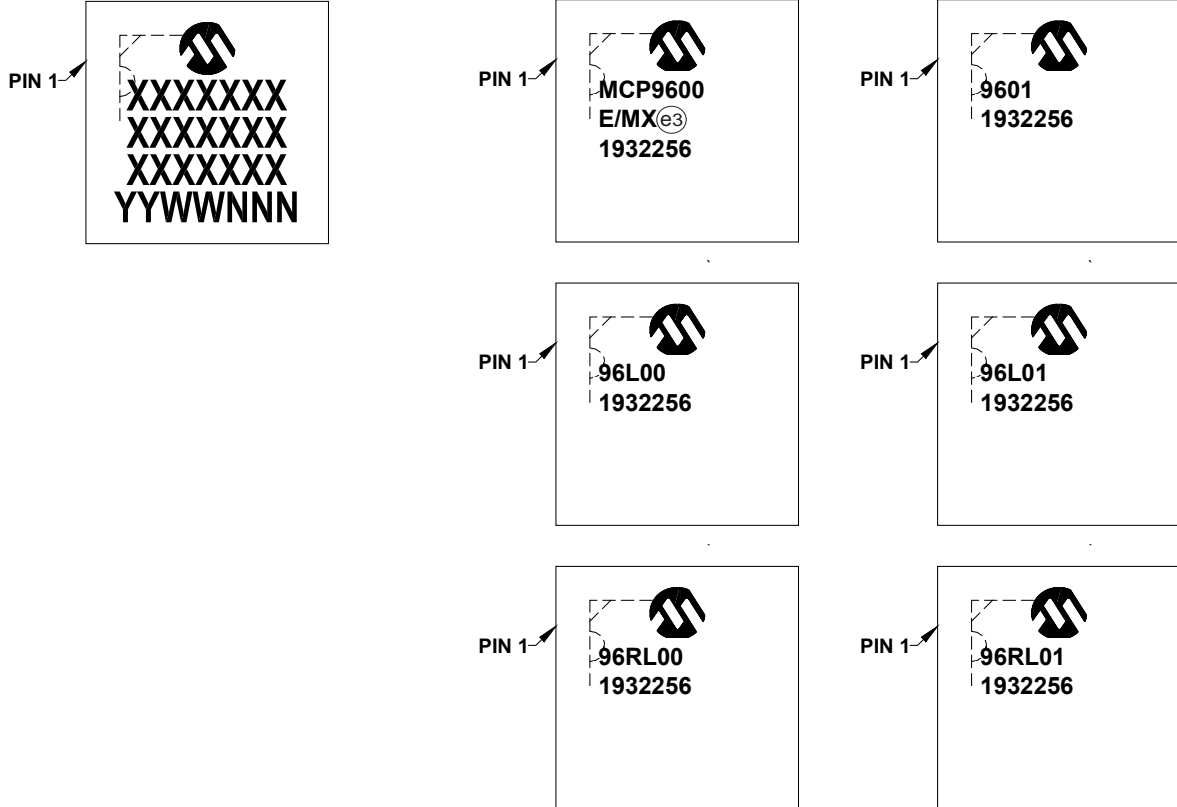

Legend:	XX...X	Customer-specific information
	Y	Year code (last digit of calendar year)
	YY	Year code (last 2 digits of calendar year)
	WW	Week code (week of January 1 is week '01')
	NNN	Alphanumeric traceability code
	(e3)	Pb-free JEDEC® designator for Matte Tin (Sn)
	*	This package is Pb-free. The Pb-free JEDEC designator (e3) can be found on the outer packaging for this package.

Note: In the event the full Microchip part number cannot be marked on one line, it will be carried over to the next line, thus limiting the number of available characters for customer-specific information.

MCP960X/L0X/RL0X

20-Lead More Thin Plastic Quad Flat, No Lead Package (NU) - 5x5x1.0 mm Body [MQFN] - (Also called VQFN)

Note: For the most current package drawings, please see the Microchip Packaging Specification located at <http://www.microchip.com/packaging>

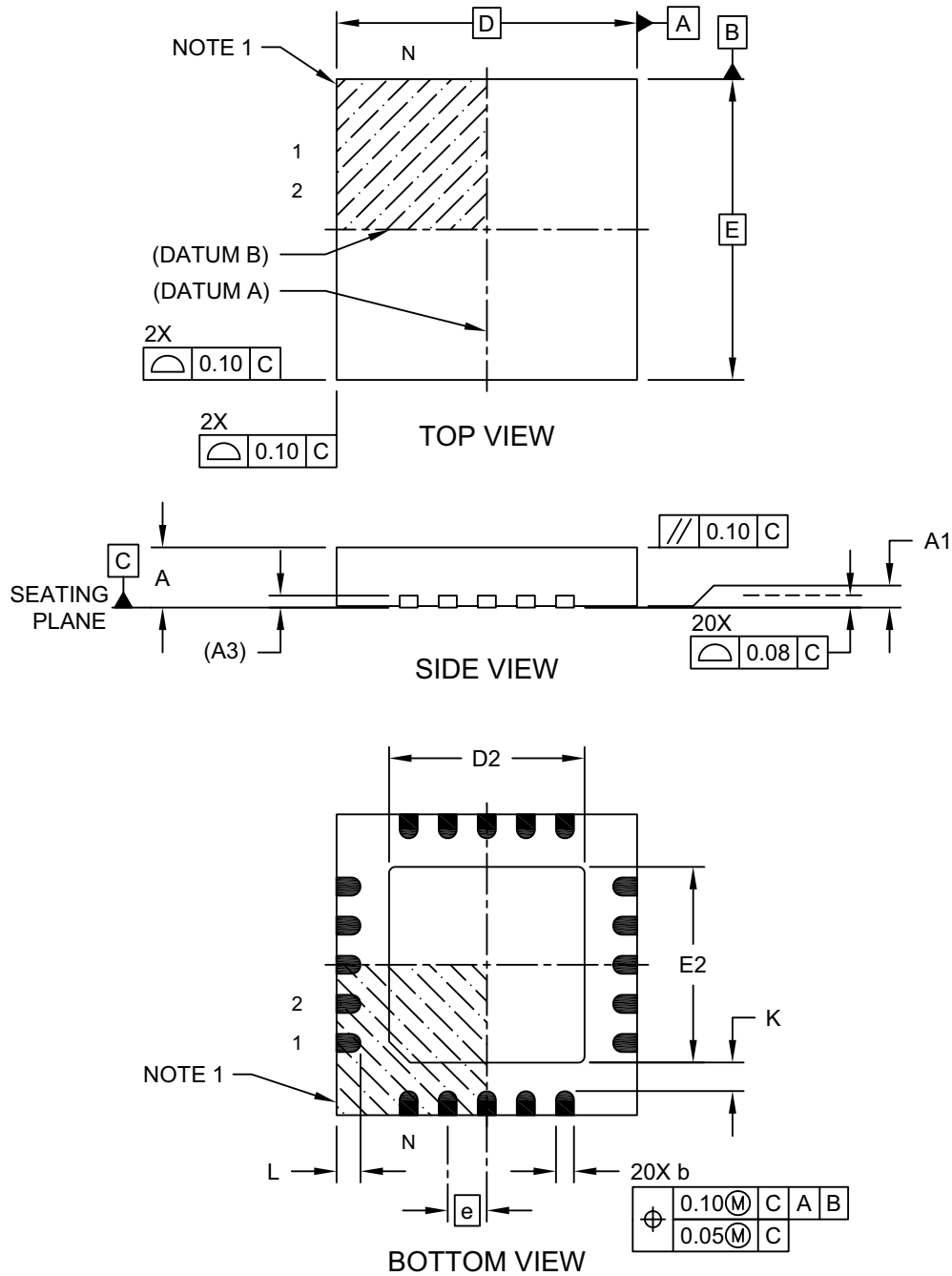

Microchip Technology Drawing C04-186B Sheet 1 of 2

MCP960X/L0X/RL0X

20-Lead More Thin Plastic Quad Flat, No Lead Package (NU) - 5x5x1.0 mm Body [MQFN] - (Also called VQFN)

Note: For the most current package drawings, please see the Microchip Packaging Specification located at <http://www.microchip.com/packaging>

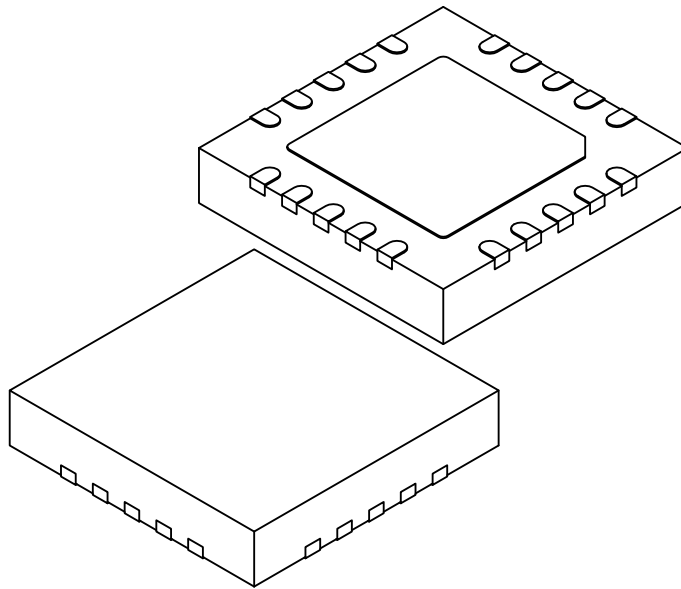

Dimension Limits	Units	MILLIMETERS		
		MIN	NOM	MAX
Number of Pins	N	20		
Pitch	e	0.65 BSC		
Overall Height	A	0.90	0.95	1.00
Standoff	A1	0.00	0.02	0.05
Terminal Thickness	A3	0.20 REF		
Overall Length	D	5.00 BSC		
Exposed Pad Length	D2	3.15	3.25	3.35
Overall Width	E	5.00 BSC		
Exposed Pad Width	E2	3.15	3.25	3.35
Terminal Width	b	0.25	0.30	0.35
Terminal Length	L	0.35	0.40	0.45
Terminal-to-Exposed-Pad	K	0.20	-	-

Notes:

1. Pin 1 visual index feature may vary, but must be located within the hatched area.
2. Package is saw singulated
3. Dimensioning and tolerancing per ASME Y14.5M

BSC: Basic Dimension. Theoretically exact value shown without tolerances.

REF: Reference Dimension, usually without tolerance, for information purposes only.

Microchip Technology Drawing C04-186B Sheet 2 of 2

MCP960X/L0X/RL0X

20-Lead More Thin Plastic Quad Flat, No Lead Package (NU) - 5x5x1.0 mm Body [MQFN] - (Also called VQFN)

Note: For the most current package drawings, please see the Microchip Packaging Specification located at <http://www.microchip.com/packaging>

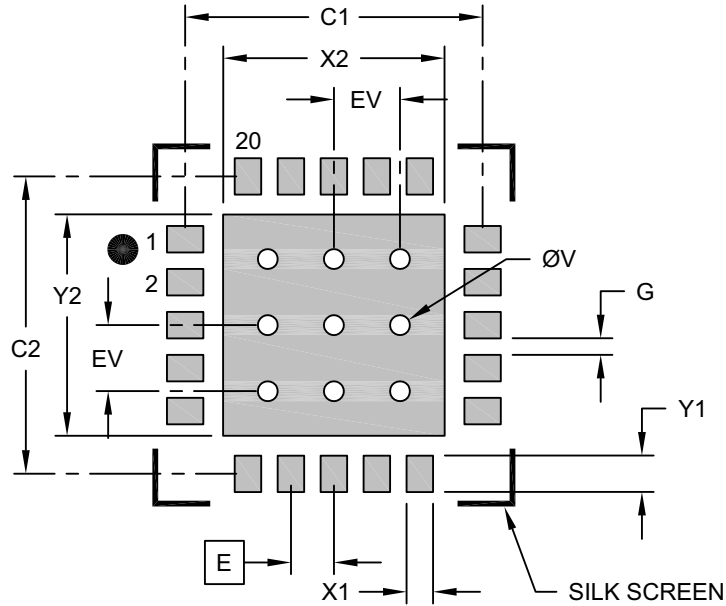

RECOMMENDED LAND PATTERN

Dimension Limits	Units	MILLIMETERS		
		MIN	NOM	MAX
Contact Pitch	E	0.65 BSC		
Optional Center Pad Width	X2			3.35
Optional Center Pad Length	Y2			3.35
Contact Pad Spacing	C1		4.50	
Contact Pad Spacing	C2		4.50	
Contact Pad Width (X20)	X1			0.40
Contact Pad Length (X20)	Y1			0.55
Distance Between Pads	G	0.20		
Thermal Via Diameter	V		0.30	
Thermal Via Pitch	EV		1.00	

Notes:

1. Dimensioning and tolerancing per ASME Y14.5M
BSC: Basic Dimension. Theoretically exact value shown without tolerances.
2. For best soldering results, thermal vias, if used, should be filled or tented to avoid solder loss during reflow process

Microchip Technology Drawing C04-186B

APPENDIX A: REVISION HISTORY

section.

Revision G (April 2021)

The following is the list of modifications:

1. Updated the [“MCP960X/L0X/RL0X Block Diagram”](#)
2. Updated bit 3 description of [Register 5-11](#).
3. Minor typographical edits.
4. Changed V_{SENSE} thresholds from the electrical specifications table (See Errata).
5. Added T_{POR} specification.
6. Updated Figure 1-1.
7. Updated Figure 6-6, 7, 9, 10, 11, 12.

Revision F (August 2019)

The following is the list of modifications:

1. Added the MCP9601/L01/RL01 device family and related information throughout the document.

Revision E (January 2019)

The following is the list of modifications:

1. Added the MCP96RL00/RL01 device and related information throughout the document.

Revision D (August 2018)

The following is the list of modifications:

1. Added the MCP96L00 device and related information throughout the document.

Revision C (September 2017)

The following is the list of modifications:

1. Updated [Figure 4-3](#), [Equation 5-1](#), [Equation 5-2](#) and [Equation 5-3](#).
2. Updated [Section 6.3.3.1 “Open-Circuit Detection Technique”](#).
3. Various typographical edits.

Revision B (June 2016)

The following is the list of modifications:

1. Corrected the pin description error for pins 19 and 20 on page 1.
2. Added the MCP9600 Evaluation Board picture on page 2.
3. Added [Section 6.3.3.1 “Open-Circuit Detection Technique”](#) and updated [Section 6.3.4 “Aliasing and Anti-Aliasing Filter”](#) and [Section 6.3.5 “ESD Protection Using Ferrite Beads”](#).
4. Updated the Product Identification System

Revision A (August 2015)

- Original release of this document.

NOTES:

MCP960X/L0X/RL0X

PRODUCT IDENTIFICATION SYSTEM

To order or obtain information, e.g., on pricing or delivery, refer to the factory or the listed sales office.

<u>PART NO.</u> ⁽¹⁾	<u>/X/</u> ⁽²⁾	<u>X</u>	<u>/XX</u>																																																												
Device	Tape and Reel Option	Temperature Range	Package																																																												
<table border="1"> <tr> <td style="vertical-align: top;">Device:</td> <td>MCP9600: Signal Conditioning IC⁽¹⁾</td> <td>Signal Conditioning IC⁽¹⁾</td> <td></td> </tr> <tr> <td></td> <td>MCP9600T: Signal Conditioning IC⁽¹⁾ (Tape and Reel)</td> <td>Signal Conditioning IC⁽¹⁾ (Tape and Reel)</td> <td></td> </tr> <tr> <td></td> <td>MCP96L00: Signal Conditioning IC⁽¹⁾</td> <td>Signal Conditioning IC⁽¹⁾</td> <td></td> </tr> <tr> <td></td> <td>MCP96L00T: Signal Conditioning IC⁽¹⁾ (Tape and Reel)</td> <td>Signal Conditioning IC⁽¹⁾ (Tape and Reel)</td> <td></td> </tr> <tr> <td></td> <td>MCP96RL00: Signal Conditioning IC⁽¹⁾</td> <td>Signal Conditioning IC⁽¹⁾</td> <td></td> </tr> <tr> <td></td> <td>MCP96RL00T: Signal Conditioning IC⁽¹⁾ (Tape and Reel)</td> <td>Signal Conditioning IC⁽¹⁾ (Tape and Reel)</td> <td></td> </tr> <tr> <td></td> <td>MCP9601: Signal Conditioning IC⁽¹⁾</td> <td>Signal Conditioning IC⁽¹⁾</td> <td></td> </tr> <tr> <td></td> <td>MCP9601T: Signal Conditioning IC⁽¹⁾ (Tape and Reel)</td> <td>Signal Conditioning IC⁽¹⁾ (Tape and Reel)</td> <td></td> </tr> <tr> <td></td> <td>MCP96L01: Signal Conditioning IC⁽¹⁾</td> <td>Signal Conditioning IC⁽¹⁾</td> <td></td> </tr> <tr> <td></td> <td>MCP96L01T: Signal Conditioning IC⁽¹⁾ (Tape and Reel)</td> <td>Signal Conditioning IC⁽¹⁾ (Tape and Reel)</td> <td></td> </tr> <tr> <td></td> <td>MCP96RL01: Signal Conditioning IC⁽¹⁾</td> <td>Signal Conditioning IC⁽¹⁾</td> <td></td> </tr> <tr> <td></td> <td>MCP96RL01T: Signal Conditioning IC⁽¹⁾ (Tape and Reel)</td> <td>Signal Conditioning IC⁽¹⁾ (Tape and Reel)</td> <td></td> </tr> <tr> <td style="vertical-align: top;">Tape and Reel Option:</td> <td>T = Tape and Reel⁽²⁾</td> <td></td> <td></td> </tr> <tr> <td style="vertical-align: top;">Temperature Range:</td> <td>E = -40°C to +125°C</td> <td></td> <td></td> </tr> <tr> <td style="vertical-align: top;">Package:</td> <td>MX = More Thin Plastic Quad Flat, MQFN, 20-Lead</td> <td></td> <td></td> </tr> </table>				Device:	MCP9600: Signal Conditioning IC ⁽¹⁾	Signal Conditioning IC ⁽¹⁾			MCP9600T: Signal Conditioning IC ⁽¹⁾ (Tape and Reel)	Signal Conditioning IC ⁽¹⁾ (Tape and Reel)			MCP96L00: Signal Conditioning IC ⁽¹⁾	Signal Conditioning IC ⁽¹⁾			MCP96L00T: Signal Conditioning IC ⁽¹⁾ (Tape and Reel)	Signal Conditioning IC ⁽¹⁾ (Tape and Reel)			MCP96RL00: Signal Conditioning IC ⁽¹⁾	Signal Conditioning IC ⁽¹⁾			MCP96RL00T: Signal Conditioning IC ⁽¹⁾ (Tape and Reel)	Signal Conditioning IC ⁽¹⁾ (Tape and Reel)			MCP9601: Signal Conditioning IC ⁽¹⁾	Signal Conditioning IC ⁽¹⁾			MCP9601T: Signal Conditioning IC ⁽¹⁾ (Tape and Reel)	Signal Conditioning IC ⁽¹⁾ (Tape and Reel)			MCP96L01: Signal Conditioning IC ⁽¹⁾	Signal Conditioning IC ⁽¹⁾			MCP96L01T: Signal Conditioning IC ⁽¹⁾ (Tape and Reel)	Signal Conditioning IC ⁽¹⁾ (Tape and Reel)			MCP96RL01: Signal Conditioning IC ⁽¹⁾	Signal Conditioning IC ⁽¹⁾			MCP96RL01T: Signal Conditioning IC ⁽¹⁾ (Tape and Reel)	Signal Conditioning IC ⁽¹⁾ (Tape and Reel)		Tape and Reel Option:	T = Tape and Reel ⁽²⁾			Temperature Range:	E = -40°C to +125°C			Package:	MX = More Thin Plastic Quad Flat, MQFN, 20-Lead		
Device:	MCP9600: Signal Conditioning IC ⁽¹⁾	Signal Conditioning IC ⁽¹⁾																																																													
	MCP9600T: Signal Conditioning IC ⁽¹⁾ (Tape and Reel)	Signal Conditioning IC ⁽¹⁾ (Tape and Reel)																																																													
	MCP96L00: Signal Conditioning IC ⁽¹⁾	Signal Conditioning IC ⁽¹⁾																																																													
	MCP96L00T: Signal Conditioning IC ⁽¹⁾ (Tape and Reel)	Signal Conditioning IC ⁽¹⁾ (Tape and Reel)																																																													
	MCP96RL00: Signal Conditioning IC ⁽¹⁾	Signal Conditioning IC ⁽¹⁾																																																													
	MCP96RL00T: Signal Conditioning IC ⁽¹⁾ (Tape and Reel)	Signal Conditioning IC ⁽¹⁾ (Tape and Reel)																																																													
	MCP9601: Signal Conditioning IC ⁽¹⁾	Signal Conditioning IC ⁽¹⁾																																																													
	MCP9601T: Signal Conditioning IC ⁽¹⁾ (Tape and Reel)	Signal Conditioning IC ⁽¹⁾ (Tape and Reel)																																																													
	MCP96L01: Signal Conditioning IC ⁽¹⁾	Signal Conditioning IC ⁽¹⁾																																																													
	MCP96L01T: Signal Conditioning IC ⁽¹⁾ (Tape and Reel)	Signal Conditioning IC ⁽¹⁾ (Tape and Reel)																																																													
	MCP96RL01: Signal Conditioning IC ⁽¹⁾	Signal Conditioning IC ⁽¹⁾																																																													
	MCP96RL01T: Signal Conditioning IC ⁽¹⁾ (Tape and Reel)	Signal Conditioning IC ⁽¹⁾ (Tape and Reel)																																																													
Tape and Reel Option:	T = Tape and Reel ⁽²⁾																																																														
Temperature Range:	E = -40°C to +125°C																																																														
Package:	MX = More Thin Plastic Quad Flat, MQFN, 20-Lead																																																														
<p>Examples:</p> <ul style="list-style-type: none"> a) MCP9600-E/MX: Extended temperature, 20-lead MQFN package b) MCP9600T-E/MX: Tape and Reel, Extended temperature, 20-lead MQFN package c) MCP96L00-E/MX: Extended Temperature, 20-lead MQFN package d) MCP96L00T-E/MX: Tape and Reel, Extended temperature, 20-lead MQFN package e) MCP96RL00-E/MX: Extended temperature, 20-lead MQFN package f) MCP96RL00T-E/MX: Tape and Reel, Extended temperature, 20-lead MQFN package g) MCP9601-E/MX: Extended temperature, 20-lead MQFN package h) MCP9601T-E/MX: Tape and Reel, Extended temperature, 20-lead MQFN package i) MCP96L01-E/MX: Extended Temperature, 20-lead MQFN package j) MCP96L01T-E/MX: Tape and Reel, Extended temperature, 20-lead MQFN package k) MCP96RL01-E/MX: Extended temperature, 20-lead MQFN package l) MCP96RL01T-E/MX: Tape and Reel, Extended temperature, 20-lead MQFN package <p>Note 1: For custom thermocouple types or custom features, please contact your local Microchip sales office. Minimum purchase volumes are required.</p> <p>2: Tape and Reel identifier only appears in the catalog part number description. This identifier is used for ordering purposes and is not printed on the device package. Check with your Microchip Sales Office for package availability with the Tape and Reel option.</p>																																																															

NOTES:

Note the following details of the code protection feature on Microchip devices:

- Microchip products meet the specification contained in their particular Microchip Data Sheet.
- Microchip believes that its family of products is one of the most secure families of its kind on the market today, when used in the intended manner and under normal conditions.
- There are dishonest and possibly illegal methods used to breach the code protection feature. All of these methods, to our knowledge, require using the Microchip products in a manner outside the operating specifications contained in Microchip's Data Sheets. Most likely, the person doing so is engaged in theft of intellectual property.
- Microchip is willing to work with the customer who is concerned about the integrity of their code.
- Neither Microchip nor any other semiconductor manufacturer can guarantee the security of their code. Code protection does not mean that we are guaranteeing the product as “unbreakable.”

Code protection is constantly evolving. We at Microchip are committed to continuously improving the code protection features of our products. Attempts to break Microchip's code protection feature may be a violation of the Digital Millennium Copyright Act. If such acts allow unauthorized access to your software or other copyrighted work, you may have a right to sue for relief under that Act.

Information contained in this publication regarding device applications and the like is provided only for your convenience and may be superseded by updates. It is your responsibility to ensure that your application meets with your specifications. MICROCHIP MAKES NO REPRESENTATIONS OR WARRANTIES OF ANY KIND WHETHER EXPRESS OR IMPLIED, WRITTEN OR ORAL, STATUTORY OR OTHERWISE, RELATED TO THE INFORMATION, INCLUDING BUT NOT LIMITED TO ITS CONDITION, QUALITY, PERFORMANCE, MERCHANTABILITY OR FITNESS FOR PURPOSE. Microchip disclaims all liability arising from this information and its use. Use of Microchip devices in life support and/or safety applications is entirely at the buyer's risk, and the buyer agrees to defend, indemnify and hold harmless Microchip from any and all damages, claims, suits, or expenses resulting from such use. No licenses are conveyed, implicitly or otherwise, under any Microchip intellectual property rights unless otherwise stated.

Trademarks

The Microchip name and logo, the Microchip logo, Adaptec, AnyRate, AVR, AVR logo, AVR Freaks, BesTime, BitCloud, chipKIT, chipKIT logo, CryptoMemory, CryptoRF, dsPIC, FlashFlex, flexPWR, HELDO, IGLOO, JukeBlox, KeeLoq, Klear, LANCheck, LinkMD, maXStylus, maXTouch, MediaLB, megaAVR, Microsemi, Microsemi logo, MOST, MOST logo, MPLAB, OptoLyzer, PackeTime, PIC, picoPower, PICSTART, PIC32 logo, PolarFire, Prochip Designer, QTouch, SAM-BA, SenGenuity, SpyNIC, SST, SST Logo, SuperFlash, Symmetricom, SyncServer, Tachyon, TempTrackr, TimeSource, tinyAVR, UNI/O, Vectron, and XMEGA are registered trademarks of Microchip Technology Incorporated in the U.S.A. and other countries.

APT, ClockWorks, The Embedded Control Solutions Company, EtherSynch, FlashTec, Hyper Speed Control, HyperLight Load, IntelliMOS, Libero, motorBench, mTouch, Powermite 3, Precision Edge, ProASIC, ProASIC Plus, ProASIC Plus logo, Quiet-Wire, SmartFusion, SyncWorld, Temux, TimeCesium, TimeHub, TimePictra, TimeProvider, Vite, WinPath, and ZL are registered trademarks of Microchip Technology Incorporated in the U.S.A.

Adjacent Key Suppression, AKS, Analog-for-the-Digital Age, Any Capacitor, AnyIn, AnyOut, BlueSky, BodyCom, CodeGuard, CryptoAuthentication, CryptoAutomotive, CryptoCompanion, CryptoController, dsPICDEM, dsPICDEM.net, Dynamic Average Matching, DAM, ECAN, EtherGREEN, In-Circuit Serial Programming, ICSP, INICnet, Inter-Chip Connectivity, JitterBlocker, KlearNet, KlearNet logo, memBrain, Mindi, MiWi, MPASM, MPF, MPLAB Certified logo, MPLIB, MPLINK, MultiTRAK, NetDetach, Omniscient Code Generation, PICDEM, PICDEM.net, PICKit, PICtail, PowerSmart, PureSilicon, QMatrix, REAL ICE, Ripple Blocker, SAM-ICE, Serial Quad I/O, SMART-I.S., SQI, SuperSwitcher, SuperSwitcher II, Total Endurance, TSHARC, USBCheck, VariSense, ViewSpan, WiperLock, Wireless DNA, and ZENA are trademarks of Microchip Technology Incorporated in the U.S.A. and other countries.

SQTP is a service mark of Microchip Technology Incorporated in the U.S.A.

The Adaptec logo, Frequency on Demand, Silicon Storage Technology, and Symmcom are registered trademarks of Microchip Technology Inc. in other countries.

GestIC is a registered trademark of Microchip Technology Germany II GmbH & Co. KG, a subsidiary of Microchip Technology Inc., in other countries.

All other trademarks mentioned herein are property of their respective companies.

© 2019, Microchip Technology Incorporated, All Rights Reserved.

ISBN: 978-1-5224-8109-6

For information regarding Microchip's Quality Management Systems, please visit www.microchip.com/quality.



MICROCHIP

Worldwide Sales and Service

AMERICAS

Corporate Office
2355 West Chandler Blvd.
Chandler, AZ 85224-6199
Tel: 480-792-7200
Fax: 480-792-7277
Technical Support:
<http://www.microchip.com/support>
Web Address:
www.microchip.com

Atlanta

Duluth, GA
Tel: 678-957-9614
Fax: 678-957-1455

Austin, TX

Tel: 512-257-3370

Boston

Westborough, MA
Tel: 774-760-0087
Fax: 774-760-0088

Chicago

Itasca, IL
Tel: 630-285-0071
Fax: 630-285-0075

Dallas

Addison, TX
Tel: 972-818-7423
Fax: 972-818-2924

Detroit

Novi, MI
Tel: 248-848-4000

Houston, TX

Tel: 281-894-5983

Indianapolis

Noblesville, IN
Tel: 317-773-8323
Fax: 317-773-5453
Tel: 317-536-2380

Los Angeles

Mission Viejo, CA
Tel: 949-462-9523
Fax: 949-462-9608
Tel: 951-273-7800

Raleigh, NC

Tel: 919-844-7510

New York, NY

Tel: 631-435-6000

San Jose, CA

Tel: 408-735-9110
Tel: 408-436-4270

Canada - Toronto

Tel: 905-695-1980
Fax: 905-695-2078

ASIA/PACIFIC

Australia - Sydney
Tel: 61-2-9868-6733

China - Beijing
Tel: 86-10-8569-7000

China - Chengdu
Tel: 86-28-8665-5511

China - Chongqing
Tel: 86-23-8980-9588

China - Dongguan
Tel: 86-769-8702-9880

China - Guangzhou
Tel: 86-20-8755-8029

China - Hangzhou
Tel: 86-571-8792-8115

China - Hong Kong SAR
Tel: 852-2943-5100

China - Nanjing
Tel: 86-25-8473-2460

China - Qingdao
Tel: 86-532-8502-7355

China - Shanghai
Tel: 86-21-3326-8000

China - Shenyang
Tel: 86-24-2334-2829

China - Shenzhen
Tel: 86-755-8864-2200

China - Suzhou
Tel: 86-186-6233-1526

China - Wuhan
Tel: 86-27-5980-5300

China - Xian
Tel: 86-29-8833-7252

China - Xiamen
Tel: 86-592-2388138

China - Zhuhai
Tel: 86-756-3210040

ASIA/PACIFIC

India - Bangalore
Tel: 91-80-3090-4444

India - New Delhi
Tel: 91-11-4160-8631

India - Pune
Tel: 91-20-4121-0141

Japan - Osaka
Tel: 81-6-6152-7160

Japan - Tokyo
Tel: 81-3-6880-3770

Korea - Daegu
Tel: 82-53-744-4301

Korea - Seoul
Tel: 82-2-554-7200

Malaysia - Kuala Lumpur
Tel: 60-3-7651-7906

Malaysia - Penang
Tel: 60-4-227-8870

Philippines - Manila
Tel: 63-2-634-9065

Singapore
Tel: 65-6334-8870

Taiwan - Hsin Chu
Tel: 886-3-577-8366

Taiwan - Kaohsiung
Tel: 886-7-213-7830

Taiwan - Taipei
Tel: 886-2-2508-8600

Thailand - Bangkok
Tel: 66-2-694-1351

Vietnam - Ho Chi Minh
Tel: 84-28-5448-2100

EUROPE

Austria - Wels
Tel: 43-7242-2244-39
Fax: 43-7242-2244-393

Denmark - Copenhagen
Tel: 45-4485-5910
Fax: 45-4485-2829

Finland - Espoo
Tel: 358-9-4520-820

France - Paris
Tel: 33-1-69-53-63-20
Fax: 33-1-69-30-90-79

Germany - Garching
Tel: 49-8931-9700

Germany - Haan
Tel: 49-2129-3766400

Germany - Heilbronn
Tel: 49-7131-72400

Germany - Karlsruhe
Tel: 49-721-625370

Germany - Munich
Tel: 49-89-627-144-0
Fax: 49-89-627-144-44

Germany - Rosenheim
Tel: 49-8031-354-560

Israel - Ra'anana
Tel: 972-9-744-7705

Italy - Milan
Tel: 39-0331-742611
Fax: 39-0331-466781

Italy - Padova
Tel: 39-049-7625286

Netherlands - Drunen
Tel: 31-416-690399
Fax: 31-416-690340

Norway - Trondheim
Tel: 47-7288-4388

Poland - Warsaw
Tel: 48-22-3325737

Romania - Bucharest
Tel: 40-21-407-87-50

Spain - Madrid
Tel: 34-91-708-08-90
Fax: 34-91-708-08-91

Sweden - Gothenberg
Tel: 46-31-704-60-40

Sweden - Stockholm
Tel: 46-8-5090-4654

UK - Wokingham
Tel: 44-118-921-5800
Fax: 44-118-921-5820