

## 3.3V Two-Channel Analog Front End

### Features

- Two Synchronous Sampling 16/24-bit Resolution Delta-Sigma A/D Converters
- 94.5 dB SINAD, -106.5 dBc Total Harmonic Distortion (THD) (up to 35th harmonic), 111 dB SFDR for Each Channel
- 2.7V - 3.6V AV<sub>DD</sub>, DV<sub>DD</sub>
- Programmable Data Rate up to 125 ksp/s
  - 4 MHz Maximum Sampling Frequency
- Oversampling Ratio up to 4096
- Ultra Low Power Shutdown Mode with <2 μA
- -122 dB Crosstalk between the Two Channels
- Low Drift 1.2V Internal Voltage Reference: 7 ppm/°C
- Differential Voltage Reference Input Pins
- High Gain PGA on Each Channel (up to 32V/V)
- Phase Delay Compensation with 1 μs Time Resolution
- Separate Modulator Output Pins for Each Channel
- Separate Data Ready Pin for Easy Synchronization
- Individual 24-bit Digital Offset and Gain Error Correction for Each Channel
- High-Speed 20 MHz SPI Interface with Mode 0,0 and 1,1 Compatibility
- Continuous Read/Write Modes for Minimum Communication
- Low Power Consumption (8.9 mW at 3.3V, 5.6 mW at 3.3V in low-power mode, typical)
- Available in Small 20-lead QFN and SSOP Packages, Pin-to-pin Compatible with MCP3901
- Extended Temperature Range: -40°C to +125°C

### Applications

- Energy Metering and Power Measurement
- Automotive
- Portable Instrumentation
- Medical and Power Monitoring
- Audio/Voice Recognition

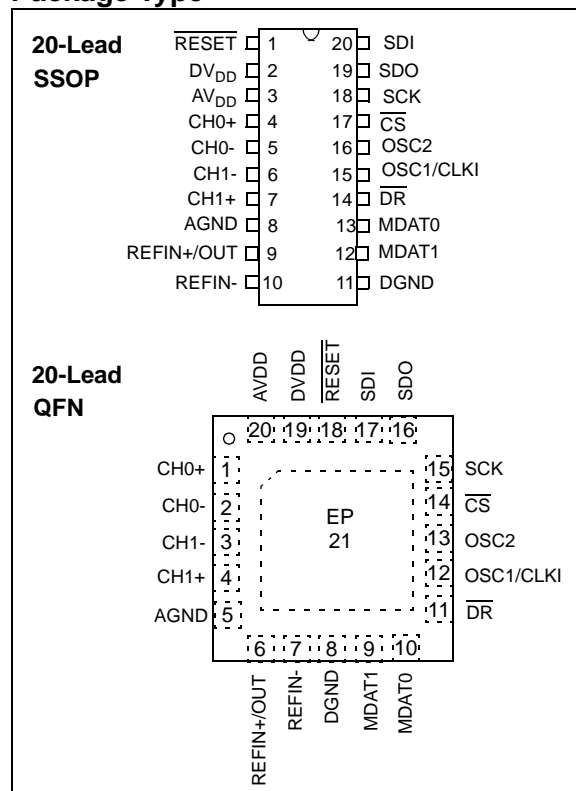
### Description

The MCP3911 is a 2.7V to 3.6V dual channel Analog Front End (AFE) containing two synchronous sampling Delta-Sigma Analog-to-Digital Converters (ADC), two PGAs, phase delay compensation block, low-drift internal voltage reference, modulator output block, digital offset and gain errors calibration registers, and high-speed 20 MHz SPI compatible serial interface.

The MCP3911 ADCs are fully configurable with features such as: 16/24-bit resolution, OSR from 32 to 4096, gain from 1x to 32x, independent shutdown and reset, dithering and auto-zeroing. The communication is largely simplified with the one-byte-long commands including various continuous read/write modes that can be accessed by the Direct Memory Access (DMA) of an MCU, and with a separate data ready pin that can be directly connected to an Interrupt Request (IRQ) input of an MCU.

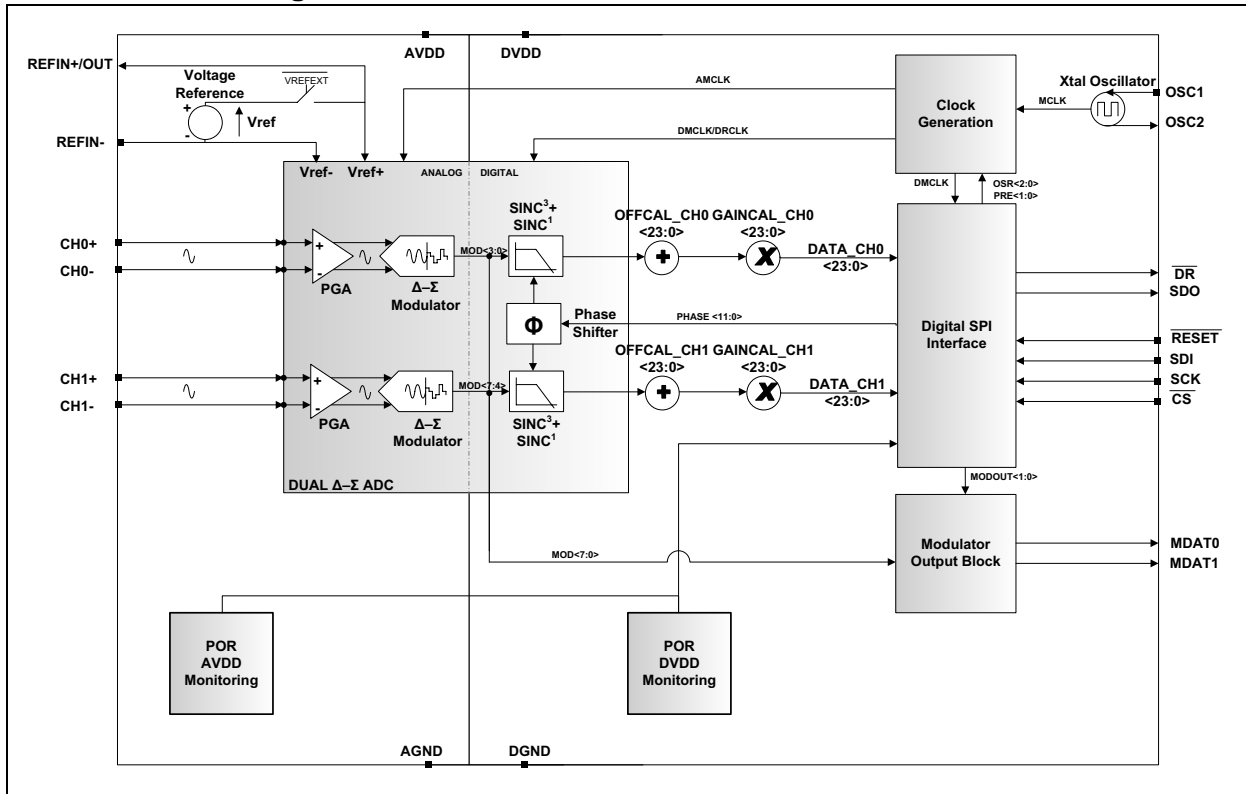
The MCP3911 is capable of interfacing a large variety of voltage and current sensors including shunts, current transformers, Rogowski coils and Hall effect sensors.

### Package Type



# MCP3911

## Functional block diagram



## 1.0 ELECTRICAL CHARACTERISTICS

### ABSOLUTE MAXIMUM RATINGS †

$V_{DD}$ .....	-0.3V to 4.0V
Digital inputs and outputs w.r.t. $A_{GND}$ .....	--0.3V to 4.0V
Analog input w.r.t. $A_{GND}$ .....	-2V to +2V
$V_{REF}$ input w.r.t. $A_{GND}$ .....	-0.6V to $V_{DD} + 0.6V$
Storage temperature .....	-65°C to +150°C
Ambient temp. with power applied .....	-65°C to +125°C
Soldering temperature of leads (10 seconds) .....	+300°C
ESD on the analog inputs (HBM,MM) .....	4.0 kV, 200V
ESD on all other pins (HBM,MM) .....	4.0 kV, 200V

† **Notice:** Stresses above those listed under “Absolute Maximum Ratings” may cause permanent damage to the device. This is a stress rating only and functional operation of the device at those or any other conditions, above those indicated in the operational listings of this specification, is not implied. Exposure to maximum rating conditions for extended periods may affect device reliability.

### 1.1 ELECTRICAL SPECIFICATIONS

**TABLE 1-1: ANALOG SPECIFICATIONS TARGET TABLE**

Sym	Characteristic	Min	Typ	Max	Units	Test Conditions
<b>Electrical Specifications:</b> Unless otherwise indicated, all parameters apply at $AV_{DD} = DV_{DD} = 2.7V$ to $3.6V$ , $MCLK = 4$ MHz; $PRE<1:0> = 00$ ; $OSR = 256$ ; $GAIN = 1$ ; $VREFEXT=0$ , $CLKEXT=1$ , $AZ\_FREQ=0$ , $DITHER<1:0>=11$ , $BOOST<1:0> = 10$ ; $V_{CM}=0V$ ; $T_A = -40^{\circ}C$ to $+125^{\circ}C$ ; $V_{IN} = 1.2 V_{PP} = 424 mV_{RMS}$ @ 50/60 Hz on both channels.						
<b>ADC Performance</b>						
	Resolution (No Missing Codes)	24	--	--	bits	$OSR = 256$ or greater
$f_S(DMCLK)$	Sampling Frequency		1	4	MHz	For maximum condition, $BOOST<1:0> = 11$
$f_D(DRCLK)$	Output Data Rate		4	125	ksps	For maximum condition, $BOOST<1:0> = 11$ , $OSR = 32$
CH0+/-	Analog Input Absolute Voltage on CH0+, CH0-, CH1+, CH1- pins	-1		+1	V	All analog input channels, measured to $AGND$
$I_{IN}$	Analog Input Leakage Current		+/-1		nA	$RESET<1:0>=11$ , $MCLK$ running continuously
$(CH_{n+}-CH_{n-})$	Differential Input Voltage Range	-600/GAIN		+600/ GAIN	mV	$V_{REF}=1.2V$ , proportional to $V_{REF}$
$V_{OS}$	Offset Error	-1	0.2	+1	mV	<b>(Note 4)</b>
	Offset Error Drift		0.5		$\mu V/^{\circ}C$	
GE	Gain Error	-4		+4	%	<b>(Note 4)</b>

- Note 1:** This specification implies that the ADC output is valid over this entire differential range and that there is no distortion or instability across this input range. Dynamic Performance specified at -0.5 dB below the maximum signal range,  $V_{IN} = 1.2V_{PP} = 424 mV_{RMS}$ ,  $V_{REF} = 1.2V$  @ 50/60 Hz. See terminology section for definition. This parameter is established by characterization and not 100% tested. See performance graphs for other than default settings provided here.
- 2:** For these operating currents the following configuration bit settings apply:  $SHUTDOWN<1:0>=00$ ,  $RESET<1:0>=00$ ,  $VREFEXT=0$ ,  $CLKEXT=0$ .
- 3:** For these operating currents the following configuration bit settings apply:  $SHUTDOWN<1:0>=11$ ,  $VREFEXT=1$ ,  $CLKEXT=1$ .
- 4:** Applies to all gains. Offset and gain errors depend on PGA gain setting, see typical performance curves for typical performance.
- 5:** Outside of this range, ADC accuracy is not specified. An extended input range of +/-2 V can be applied continuously to the part with no damage.
- 6:** For proper operation, and for optimizing ADC accuracy,  $AMCLK$  should be limited to the maximum frequency defined in the [Table 5-2](#) as a function of the  $BOOST$  and  $PGA$  setting chosen.  $MCLK$  can take larger values as long as the prescaler settings ( $PRE<1:0>$ ) limit  $AMCLK=MCLK/PRESCALE$  in the defined range in the [Table 5-2](#).

# MCP3911

**TABLE 1-1: ANALOG SPECIFICATIONS TARGET TABLE (CONTINUED)**

**Electrical Specifications:** Unless otherwise indicated, all parameters apply at  $V_{DD} = DV_{DD} = 2.7V$  to  $3.6V$ ,  $MCLK = 4$  MHz;  $PRE<1:0> = 00$ ;  $OSR = 256$ ;  $GAIN = 1$ ;  $VREFEXT=0$ ,  $CLKEXT=1$ ,  $AZ\_FREQ=0$ ,  $DITHER<1:0>=11$ ,  $BOOST<1:0> = 10$ ;  $V_{CM}=0V$ ;  $T_A = -40^{\circ}C$  to  $+125^{\circ}C$ ;  $V_{IN} = 1.2$   $V_{PP} = 424$   $mV_{RMS}$  @ 50/60 Hz on both channels.

Sym	Characteristic	Min	Typ	Max	Units	Test Conditions
	Gain Error Drift		1		ppm/ $^{\circ}C$	
INL	Integral Non-Linearity		5		ppm	
$Z_{IN}$	Differential Input Impedance	232	—	—	k $\Omega$	G=1, proportional to 1/AMCLK
		142	—	—	k $\Omega$	G=2, proportional to 1/AMCLK
		72	—	—	k $\Omega$	G=4, proportional to 1/AMCLK
		38	—	—	k $\Omega$	G=8, proportional to 1/AMCLK
		36	—	—	k $\Omega$	G=16, proportional to 1/AMCLK
		33	—	—	k $\Omega$	G=32, proportional to 1/AMCLK
SINAD	Signal-to-Noise and Distortion Ratio (Note 1)	92	94.5	—	dB	
THD	Total Harmonic Distortion (Note 1)		-106.5	-103	dBc	Includes the first 35 harmonics
SNR	Signal to Noise Ratio (Note 1)	92	95		dB	
SFDR	Spurious Free Dynamic Range (Note 1)		111		dBFS	
CTALK	Crosstalk (50, 60 Hz)	—	-122	—	dB	
AC PSRR	AC Power Supply Rejection	—	-73	—	dB	$V_{DD} = DV_{DD} = 3.3V + 0.6V_{pp}$ , 50/60 Hz, 100/120 Hz
DC PSRR	DC Power Supply Rejection	—	-73	—	dB	$V_{DD} = DV_{DD} = 2.7V$ to $3.6V$
DC CMRR	DC Common Mode Rejection	—	-105	—	dB	$V_{CM}$ from $-1V$ to $+1V$
<b>Internal Voltage Reference</b>						
$V_{REF}$	Tolerance	1.176	1.2	1.224	V	$VREFEXT = 0$ , $T_A = 25^{\circ}C$ only
$TCV_{REF}$	Temperature Coefficient	—	7	—	ppm/ $^{\circ}C$	$T_A = -40^{\circ}C$ to $+125^{\circ}C$ , $VREFEXT = 0$

**Note 1:** This specification implies that the ADC output is valid over this entire differential range and that there is no distortion or instability across this input range. Dynamic Performance specified at  $-0.5$  dB below the maximum signal range,  $V_{IN} = 1.2V_{PP} = 424$   $mV_{RMS}$ ,  $V_{REF} = 1.2V$  @ 50/60 Hz. See terminology section for definition. This parameter is established by characterization and not 100% tested. See performance graphs for other than default settings provided here.

- 2: For these operating currents the following configuration bit settings apply:  $SHUTDOWN<1:0>=00$ ,  $RESET<1:0>=00$ ,  $VREFEXT=0$ ,  $CLKEXT=0$ .
- 3: For these operating currents the following configuration bit settings apply:  $SHUTDOWN<1:0>=11$ ,  $VREFEXT=1$ ,  $CLKEXT=1$ .
- 4: Applies to all gains. Offset and gain errors depend on PGA gain setting, see typical performance curves for typical performance.
- 5: Outside of this range, ADC accuracy is not specified. An extended input range of  $\pm 2$  V can be applied continuously to the part with no damage.
- 6: For proper operation, and for optimizing ADC accuracy, AMCLK should be limited to the maximum frequency defined in the Table 5-2 as a function of the BOOST and PGA setting chosen. MCLK can take larger values as long as the prescaler settings ( $PRE<1:0>$ ) limit  $AMCLK=MCLK/PRESCALE$  in the defined range in the Table 5-2.

**TABLE 1-1: ANALOG SPECIFICATIONS TARGET TABLE (CONTINUED)**

<b>Electrical Specifications:</b> Unless otherwise indicated, all parameters apply at $V_{DD} = DV_{DD} = 2.7V$ to $3.6V$ , $MCLK = 4$ MHz; $PRE<1:0> = 00$ ; $OSR = 256$ ; $GAIN = 1$ ; $VREFEXT=0$ , $CLKEXT=1$ , $AZ\_FREQ=0$ , $DITHER<1:0>=11$ , $BOOST<1:0> = 10$ ; $V_{CM}=0V$ ; $T_A = -40^{\circ}C$ to $+125^{\circ}C$ ; $V_{IN} = 1.2 V_{PP} = 424 mV_{RMS}$ @ 50/60 Hz on both channels.						
Sym	Characteristic	Min	Typ	Max	Units	Test Conditions
ZOUTV <sub>REF</sub>	Output Impedance		2	—	k $\Omega$	VREFEXT = 0
AI <sub>DD</sub> V <sub>REF</sub>	Internal Voltage Reference Operating Current		25	—	$\mu A$	VREFEXT=0, SHUT-DOWN<1:0>=11
<b>Voltage Reference Input</b>						
	Input Capacitance	—	—	10	pF	
V <sub>REF</sub>	Differential Input Voltage Range (VREF+ - VREF -)	1.1	—	1.3	V	VREFEXT = 1
V <sub>REF+</sub>	Absolute Voltage on REFIN+ pin	V <sub>REF-</sub> + 1.1	—	V <sub>REF-</sub> + 1.3	V	VREFEXT = 1
V <sub>REF-</sub>	Absolute Voltage REFIN- pin	-0.1	—	+0.1	V	REFIN- should be connected to AGND when VREFEXT=0
<b>Master Clock Input</b>						
f <sub>MCLK</sub>	Master Clock Input Frequency Range		—	20	MHz	CLKEXT = 1, (Note 6)
f <sub>XTAL</sub>	Crystal Oscillator Operating Frequency Range	1	—	20	MHz	CLKEXT = 0, (Note 6)
AMCLK	Analog Master Clock	—	—	16	MHz	(Note 6)
<b>Power Supply</b>						
AV <sub>DD</sub>	Operating Voltage, Analog	2.7	—	3.6	V	
DV <sub>DD</sub>	Operating Voltage, Digital	2.7	—	3.6	V	
I <sub>DD,A</sub>	Operating Current, Analog (Note 2)	—	1.5	2.3	mA	BOOST<1:0>=00
		—	1.8	2.8	mA	BOOST<1:0>=01
		—	2.5	3.5	mA	BOOST<1:0>=10
		—	4.4	6.25	mA	BOOST<1:0>= 11
I <sub>DD,D</sub>	Operating Current, Digital	—	0.2	0.3	mA	MCLK = 4 MHz, proportional to MCLK
		—	0.7	—	mA	MCLK = 16 MHz, proportional to MCLK
I <sub>DDS,A</sub>	Shutdown Current, Analog	—	—	1	$\mu A$	AV <sub>DD</sub> pin only (Note 3)
I <sub>DDS,D</sub>	Shutdown Current, Digital	—	—	1	$\mu A$	DV <sub>DD</sub> pin only (Note 3)

**Note 1:** This specification implies that the ADC output is valid over this entire differential range and that there is no distortion or instability across this input range. Dynamic Performance specified at -0.5 dB below the maximum signal range,  $V_{IN} = 1.2V_{PP} = 424 mV_{RMS}$ ,  $V_{REF} = 1.2V$  @ 50/60 Hz. See terminology section for definition. This parameter is established by characterization and not 100% tested. See performance graphs for other than default settings provided here.

- 2: For these operating currents the following configuration bit settings apply: SHUTDOWN<1:0>=00, RESET<1:0>=00, VREFEXT=0, CLKEXT=0.
- 3: For these operating currents the following configuration bit settings apply: SHUTDOWN<1:0>=11, VREFEXT=1, CLKEXT=1.
- 4: Applies to all gains. Offset and gain errors depend on PGA gain setting, see typical performance curves for typical performance.
- 5: Outside of this range, ADC accuracy is not specified. An extended input range of +/-2 V can be applied continuously to the part with no damage.
- 6: For proper operation, and for optimizing ADC accuracy, AMCLK should be limited to the maximum frequency defined in the Table 5-2 as a function of the BOOST and PGA setting chosen. MCLK can take larger values as long as the prescaler settings (PRE<1:0>) limit  $AMCLK=MCLK/PRESCALE$  in the defined range in the Table 5-2.

# MCP3911

## 1.2 SERIAL INTERFACE CHARACTERISTICS

**TABLE 1-2: SERIAL DC CHARACTERISTICS TABLE**

<b>Electrical Specifications:</b> Unless otherwise indicated, all parameters apply at $DV_{DD} = 2.7$ to $3.6V$ , $T_A = -40^\circ C$ to $+125^\circ C$ , $C_{LOAD} = 30pF$ , applies to all digital I/O.						
Sym	Characteristics	Min	Typ	Max	Units	Test Conditions
V <sub>IH</sub>	High-level Input voltage	0.7 $DV_{DD}$	—		V	Schmitt Triggered
V <sub>IL</sub>	Low-level Input voltage		—	0.3 $DV_{DD}$	V	Schmitt Triggered
I <sub>LI</sub>	Input leakage current	—	—	±1	μA	$\overline{CS} = DV_{DD}$ , $V_{IN} = DGND$ TO $DV_{DD}$
I <sub>LO</sub>	Output leakage current	—	—	±1	μA	$\overline{CS} = DV_{DD}$ , $V_{OUT} = DGND$ OR $DV_{DD}$
V <sub>HYS</sub>	Hysteresis of Schmitt Trigger Inputs	—	200		mV	(Note 2), $DV_{DD} = 3.3V$ only
V <sub>OL</sub>	Low-level output voltage	—	—	0.4	V	$I_{OL} = +2.1mA$ , $DV_{DD} = 3.3V$
V <sub>OH</sub>	High-level output voltage	$DV_{DD} - 0.5$	—	—	V	$I_{OH} = -2.1mA$ , $DV_{DD} = 3.3V$
C <sub>INT</sub>	Internal capacitance (all inputs and outputs)	—	—	7	pF	$T_A = 25^\circ C$ , $SCK = 1.0 MHz$ , $DV_{DD} = 3.3V$ (Note 1)

**Note 1:** This parameter is periodically sampled and not 100% tested.

**Note 2:** This parameter is established by characterization and not production tested.

**TABLE 1-3: SERIAL AC CHARACTERISTICS TABLE**

<b>Electrical Specifications:</b> Unless otherwise indicated, all parameters apply at $DV_{DD} = 2.7$ to $3.6V$ , $T_A = -40^\circ C$ to $+125^\circ C$ , $GAIN = 1$ , $C_{LOAD} = 30pF$ .						
Sym	Characteristics	Min	Typ	Max	Units	Test Conditions
f <sub>SCK</sub>	Serial Clock frequency	—	—	20	MHz	
t <sub>CSS</sub>	$\overline{CS}$ setup time	25	—	—	ns	
t <sub>CSH</sub>	$\overline{CS}$ hold time	50	—	—	ns	
t <sub>CSD</sub>	$\overline{CS}$ disable time	50	—	—	ns	
t <sub>SU</sub>	Data setup time	5	—	—	ns	
t <sub>HD</sub>	Data hold time	10	—	—	ns	
t <sub>HI</sub>	Serial Clock high time	20	—	—	ns	
t <sub>LO</sub>	Serial Clock low time	20	—	—	ns	
t <sub>CLD</sub>	Serial Clock delay time	50	—	—	ns	
t <sub>CLE</sub>	Serial Clock enable time	50	—	—	ns	
t <sub>DO</sub>	Output valid from SCK low	—	—	25	ns	
t <sub>DOMDAT</sub>	Modulator output valid from AMCLK high	—	—	1/(2*AMCLK)	s	
t <sub>HO</sub>	Output hold time	0	—	—	ns	(Note 1)
t <sub>DIS</sub>	Output disable time	—	—	25	ns	(Note 1)
t <sub>MCLR</sub>	Reset Pulse Width (RESET)	100	—	—	ns	
t <sub>DODR</sub>	Data Transfer Time to DR (Data Ready)		—	25	ns	(Note 2)

**Note 1:** This parameter is periodically sampled and not 100% tested.

**Note 2:** This parameter is established by characterization and not production tested.

**TABLE 1-3: SERIAL AC CHARACTERISTICS TABLE (CONTINUED)**

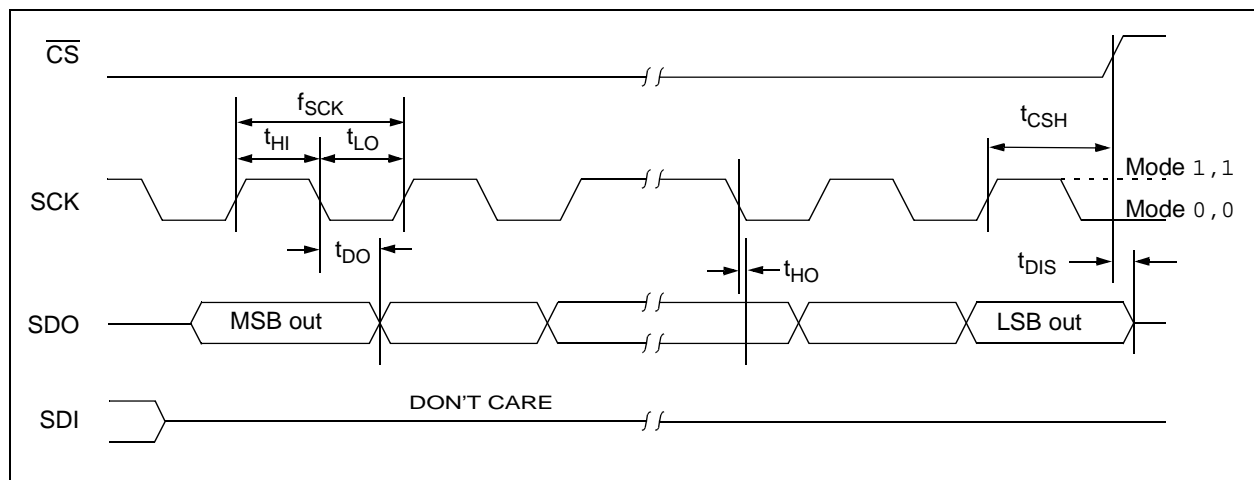
<b>Electrical Specifications:</b> Unless otherwise indicated, all parameters apply at $DV_{DD} = 2.7$ to $3.6V$ , $T_A = -40^{\circ}C$ to $+125^{\circ}C$ , $GAIN = 1$ , $C_{LOAD} = 30pF$ .						
Sym	Characteristics	Min	Typ	Max	Units	Test Conditions
$t_{MODSU}$	Modulator Mode Entry to Modulator Data Present		—	100	ns	
$t_{DRP}$	Data Ready Pulse Low Time		1/DMCLK	—	$\mu s$	

- Note 1:** This parameter is periodically sampled and not 100% tested.  
**Note 2:** This parameter is established by characterization and not production tested.

**TABLE 1-4: TEMPERATURE SPECIFICATIONS TABLE**

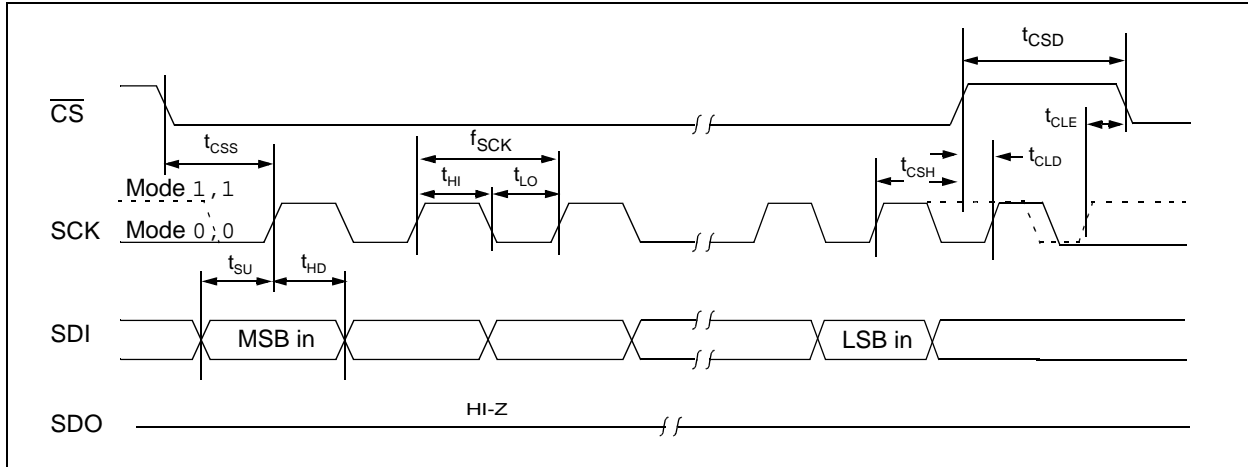
<b>Electrical Specifications:</b> Unless otherwise indicated, all parameters apply at $AV_{DD} = 2.7$ to $3.6V$ , $DV_{DD} = 2.7$ to $3.6V$ .						
Parameters	Sym	Min	Typ	Max	Units	Conditions
<b>Temperature Ranges</b>						
Operating Temperature Range	$T_A$	-40	—	+125	$^{\circ}C$	(Note 1)
Storage Temperature Range	$T_A$	-65	—	+150	$^{\circ}C$	
<b>Thermal Package Resistances</b>						
Thermal Resistance, 20L SSOP	$\theta_{JA}$	—	89.3	—	$^{\circ}C/W$	
Thermal Resistance, 20L QFN	$\theta_{JA}$	—	43	—	$^{\circ}C/W$	

- Note 1:** The internal junction temperature ( $T_J$ ) must not exceed the absolute maximum specification of  $+150^{\circ}C$ .

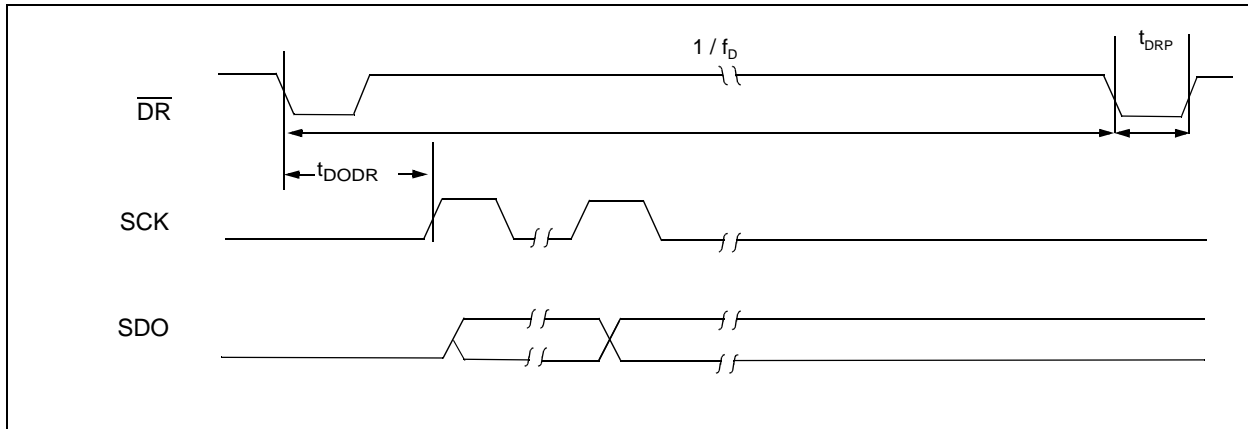


**FIGURE 1-1: Serial Output Timing Diagram.**

# MCP3911

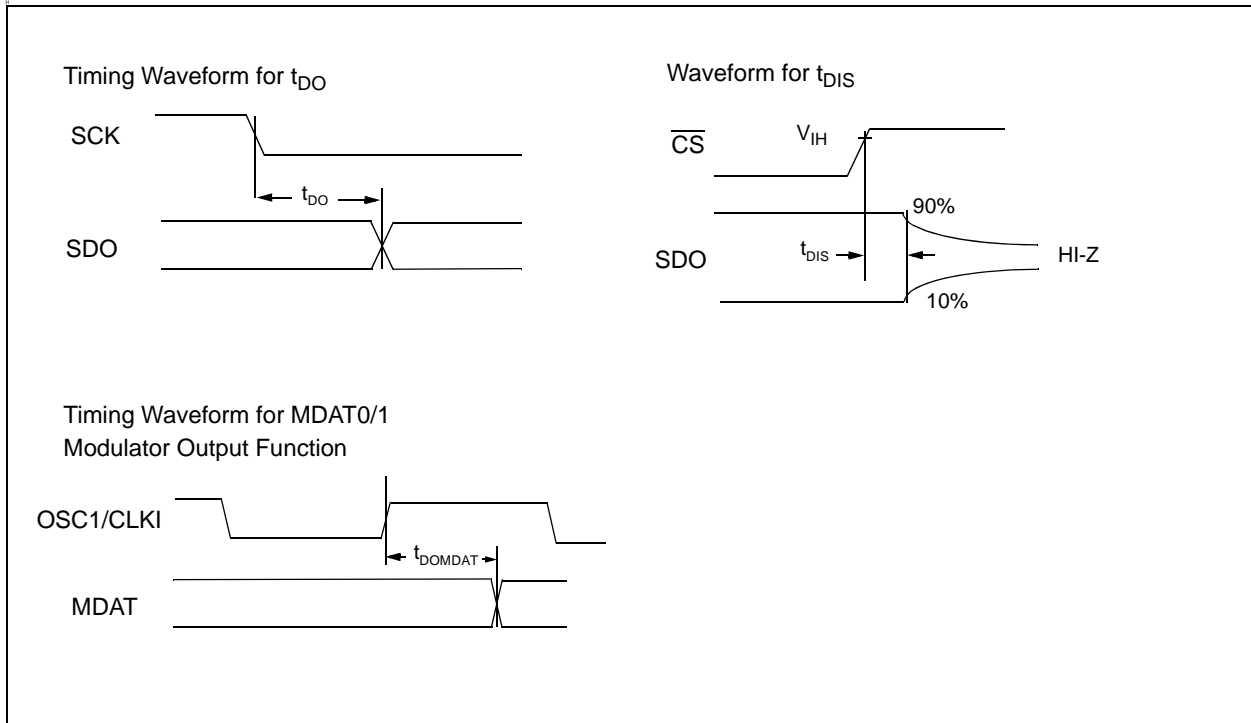


**FIGURE 1-2:** Serial Input Timing Diagram.



**FIGURE 1-3:** Data Ready Pulse / Sampling Timing Diagram.





**FIGURE 1-4:** Timing Diagrams, continued.

# MCP3911

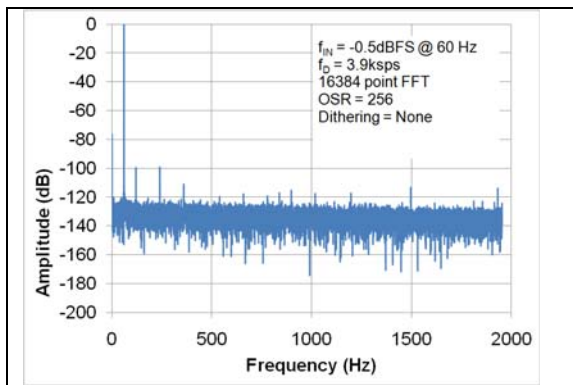
---

NOTES:

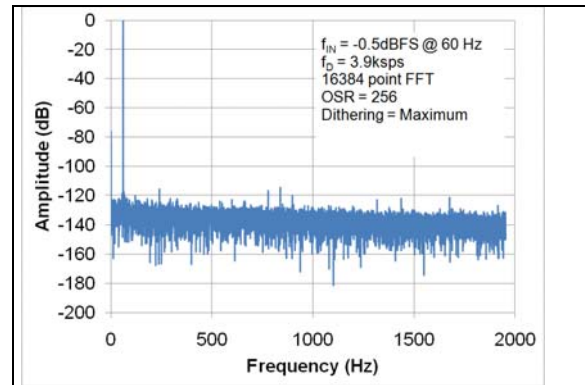
## 2.0 TYPICAL PERFORMANCE CURVES

**Note:** The graphs and tables provided following this note are a statistical summary based on a limited number of samples and are provided for informational purposes only. The performance characteristics listed herein are not tested or guaranteed. In some graphs or tables, the data presented may be outside the specified operating range (e.g., outside specified power supply range) and therefore outside the warranted range.

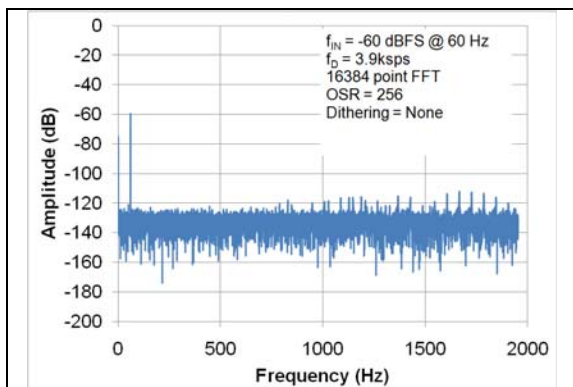
**Note:** Unless otherwise indicated,  $AV_{DD} = 3.3V$ ,  $DV_{DD} = 3.3V$ ;  $T_A = 25^\circ C$ ,  $MCLK = 4\text{ MHz}$ ;  $PRESCALE = 1$ ;  $OSR = 256$ ;  $GAIN = 1$ ;  $Dithering = Maximum$ ;  $V_{IN} = -0.5\text{ dBFS @ }60\text{ Hz}$ ,  $VREFEXT = 0$ ;  $CLKEXT = 1$ ,  $AZ\_FREQ = 0$ ;  $BOOST = 1X$ .



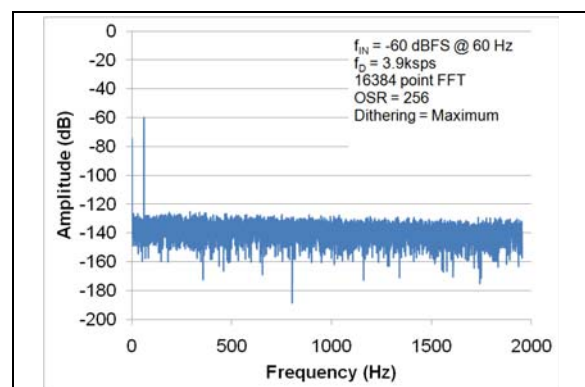
**FIGURE 2-1:** Spectral Response.



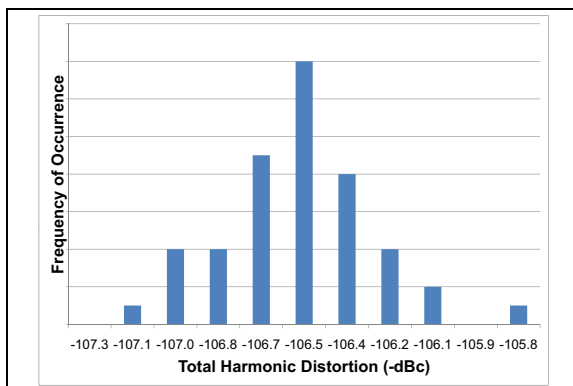
**FIGURE 2-4:** Spectral Response.



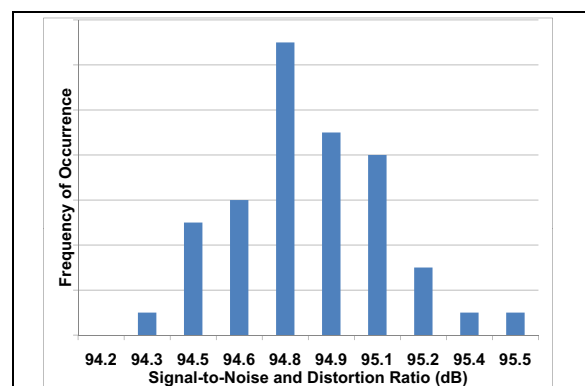
**FIGURE 2-2:** Spectral Response.



**FIGURE 2-5:** Spectral Response.



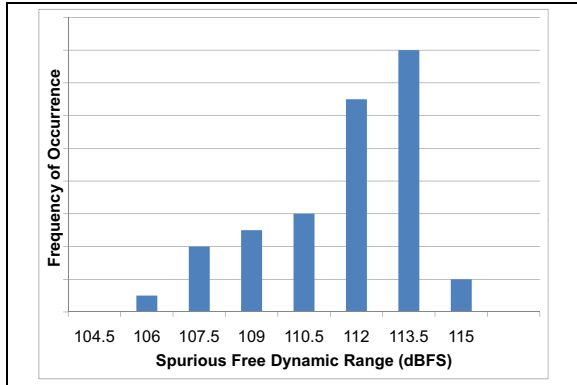
**FIGURE 2-3:** THD Histogram.



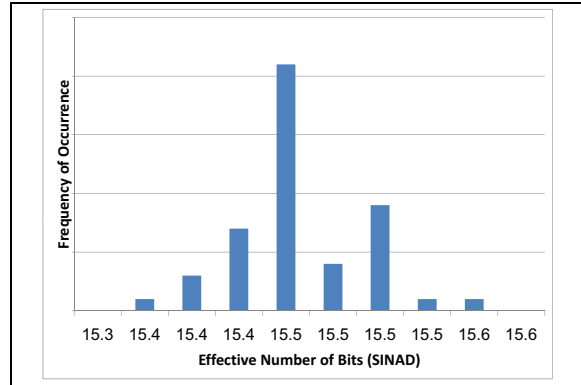
**FIGURE 2-6:** SINAD Histogram.

# MCP3911

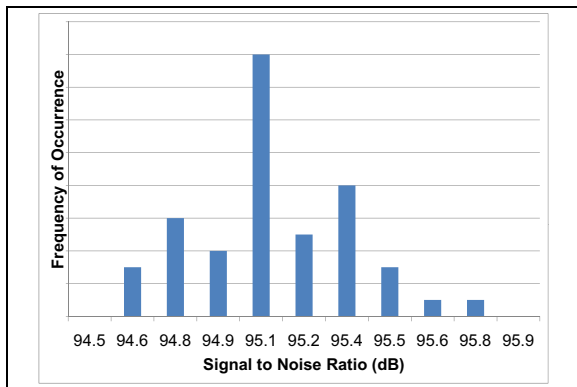
**Note:** Unless otherwise indicated,  $AV_{DD} = 3.3V$ ,  $DV_{DD} = 3.3V$ ;  $T_A = 25^\circ C$ ,  $MCLK = 4\text{ MHz}$ ;  $PRESCALE = 1$ ;  $OSR = 256$ ;  $GAIN = 1$ ;  $Dithering = \text{Maximum}$ ;  $V_{IN} = -0.5\text{ dBFS @ } 60\text{ Hz}$ ,  $V_{REFEXT} = 0$ ;  $CLKEXT = 1$ ,  $AZ\_FREQ = 0$ ;  $BOOST = 1X$ .



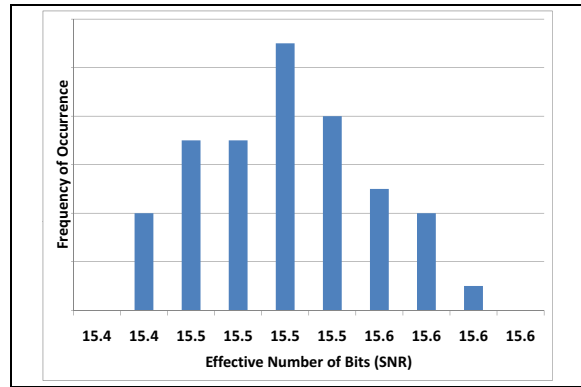
**FIGURE 2-7:** Spurious Free Dynamic Range Histogram.



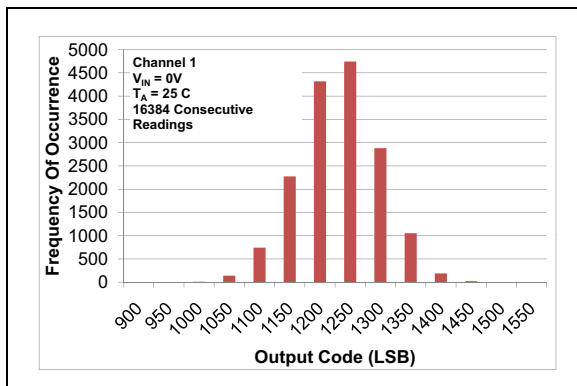
**FIGURE 2-10:** ENOB SINAD Histogram.



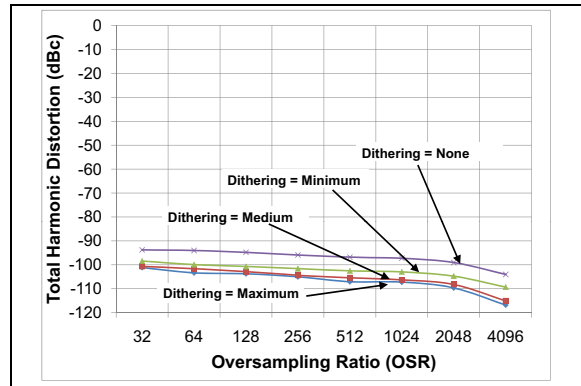
**FIGURE 2-8:** SNR Histogram.



**FIGURE 2-11:** ENOB SNR Histogram.

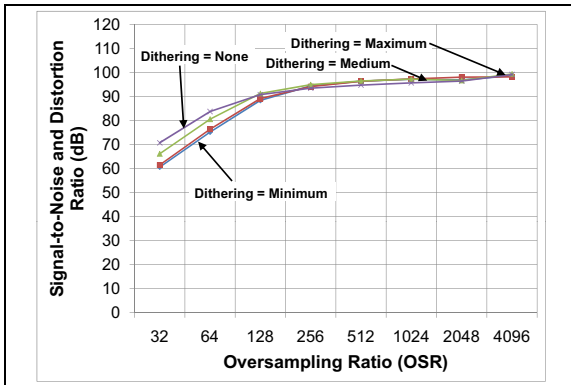


**FIGURE 2-9:** Noise Histogram.

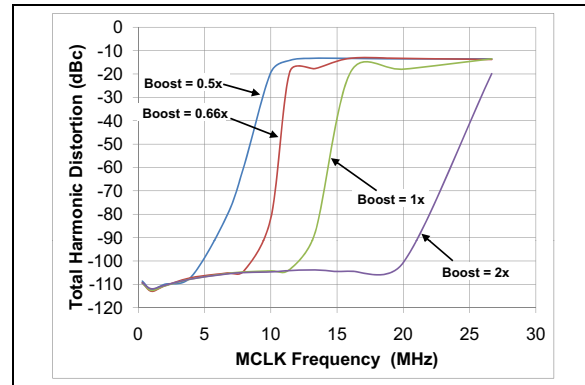


**FIGURE 2-12:** THD vs. OSR.

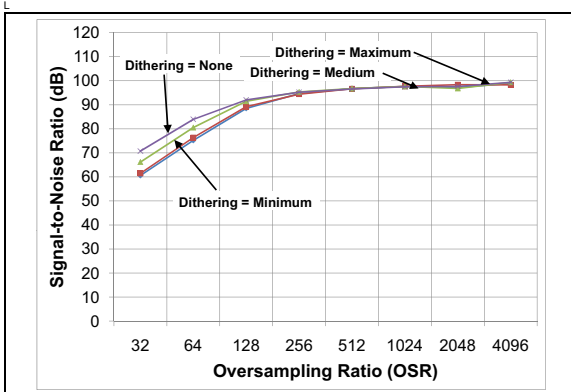
**Note:** Unless otherwise indicated, AVDD = 3.3V, DVDD = 3.3V; TA = 25 °C, MCLK = 4 MHz; PRESCALE = 1; OSR = 256; GAIN = 1; Dithering = Maximum; VIN = -0.5 dBFS @ 60 Hz, VREFEXT = 0; CLKEXT = 1, AZ\_FREQ = 0; BOOST = 1X.



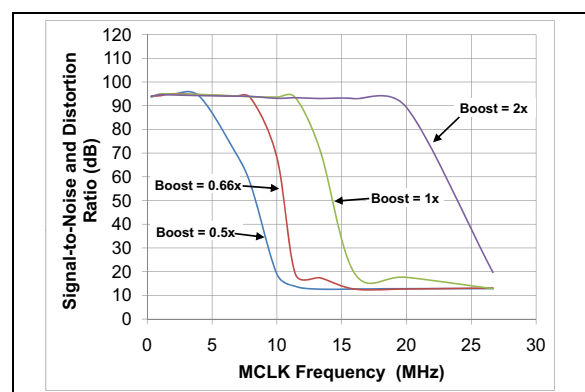
**FIGURE 2-13:** SINAD vs. OSR.



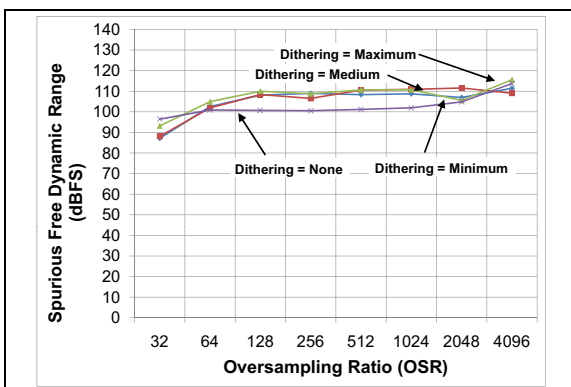
**FIGURE 2-16:** THD vs. MCLK.



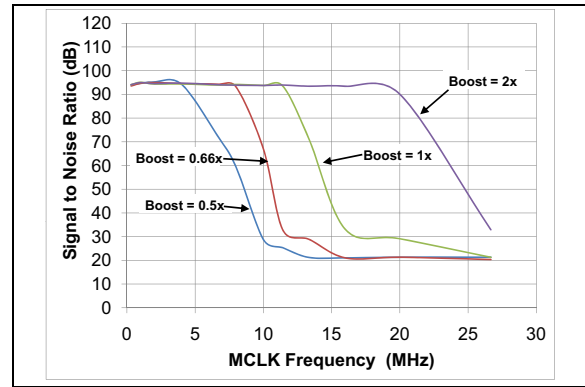
**FIGURE 2-14:** SNR vs. OSR.



**FIGURE 2-17:** SINAD vs. MCLK.



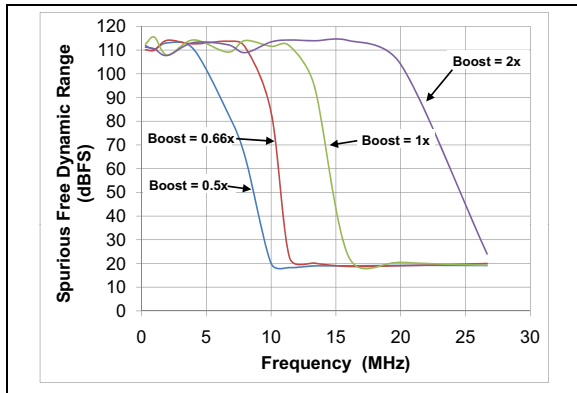
**FIGURE 2-15:** SFDR vs. OSR.



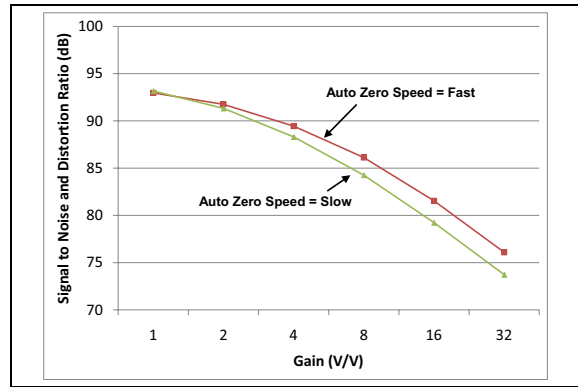
**FIGURE 2-18:** SNR vs. MCLK.

# MCP3911

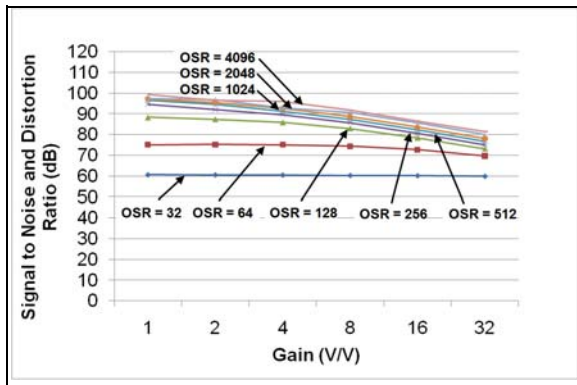
**Note:** Unless otherwise indicated,  $AV_{DD} = 3.3V$ ,  $DV_{DD} = 3.3V$ ;  $T_A = 25^\circ C$ ,  $MCLK = 4MHz$ ;  $PRESCALE = 1$ ;  $OSR = 256$ ;  $GAIN = 1$ ;  $Dithering = Maximum$ ;  $V_{IN} = -0.5dBFS @ 60Hz$ ,  $V_{REFEXT} = 0$ ;  $CLKEXT = 1$ ,  $AZ\_FREQ = 0$ ;  $BOOST = 1X$ .



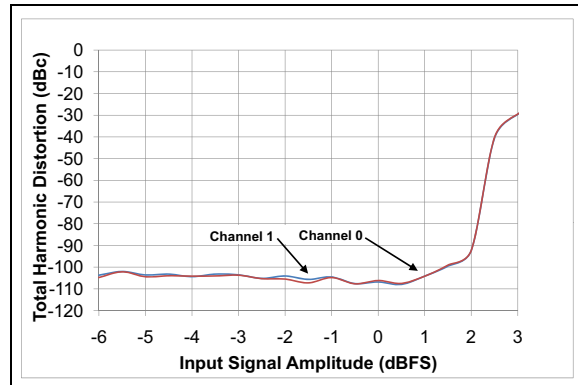
**FIGURE 2-19:** SFDR vs. MCLK.



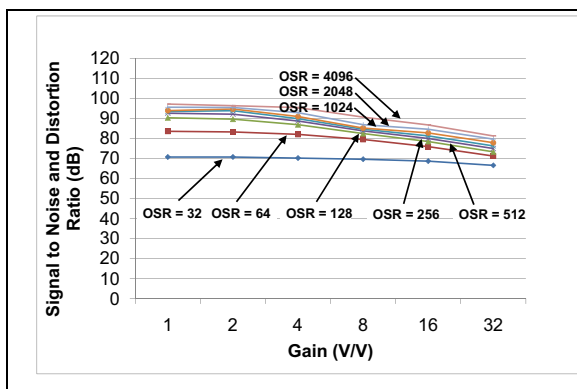
**FIGURE 2-22:** SINAD vs. GAIN vs. AZ Speed Chart.



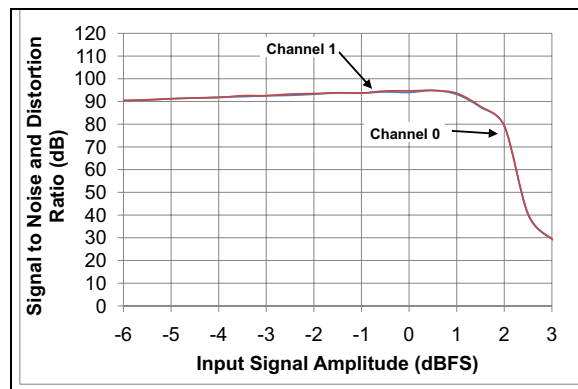
**FIGURE 2-20:** SINAD vs. GAIN.



**FIGURE 2-23:** THD vs. Input Signal Amplitude.

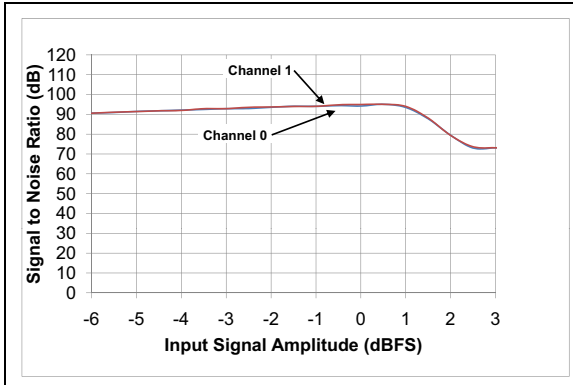


**FIGURE 2-21:** SINAD vs. GAIN (Dithering Off).

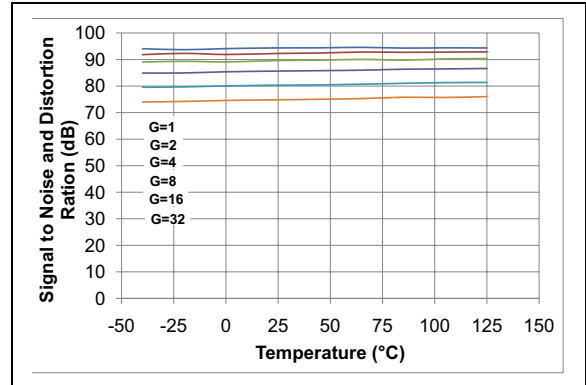


**FIGURE 2-24:** SINAD vs. Input Signal Amplitude.

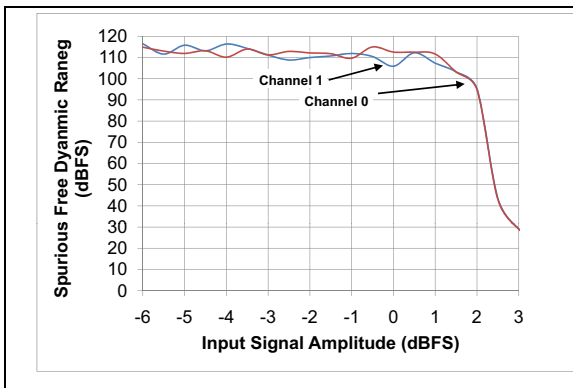
**Note:** Unless otherwise indicated,  $AV_{DD} = 3.3V$ ,  $DV_{DD} = 3.3V$ ;  $T_A = 25^\circ C$ ,  $MCLK = 4\text{ MHz}$ ;  $PRESCALE = 1$ ;  $OSR = 256$ ;  $GAIN = 1$ ; Dithering = Maximum;  $V_{IN} = -0.5\text{ dBFS @ }60\text{ Hz}$ ,  $VREFEXT = 0$ ;  $CLKEXT = 1$ ,  $AZ\_FREQ = 0$ ;  $BOOST = 1X$ .



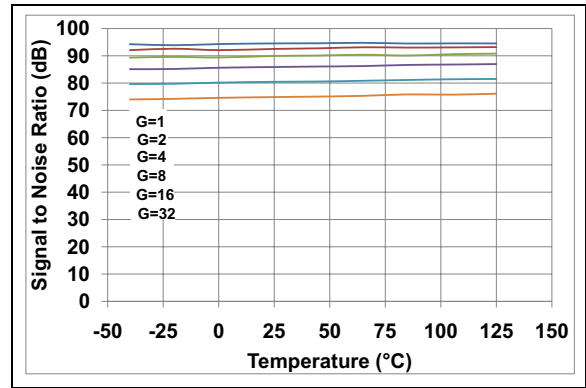
**FIGURE 2-25:** SNR vs. Input Signal Amplitude.



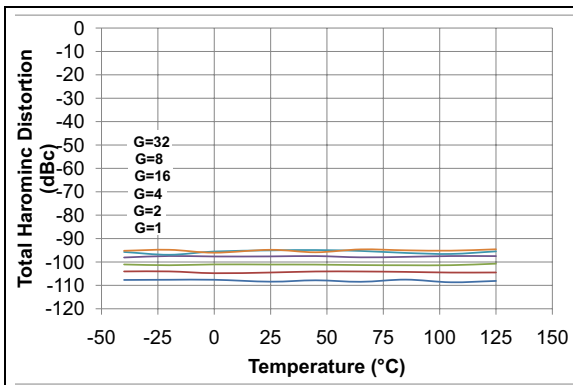
**FIGURE 2-28:** SINAD vs. Temperature.



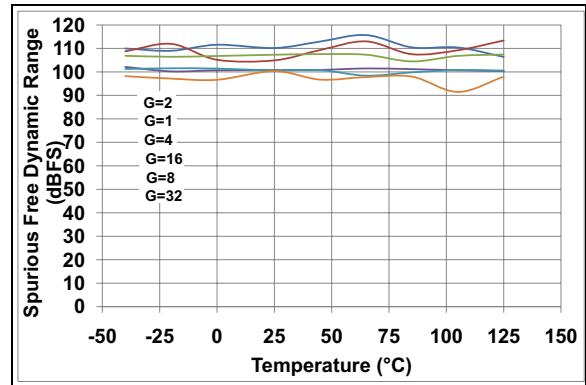
**FIGURE 2-26:** SFDR vs. Input Signal Amplitude.



**FIGURE 2-29:** SNR vs. Temperature.



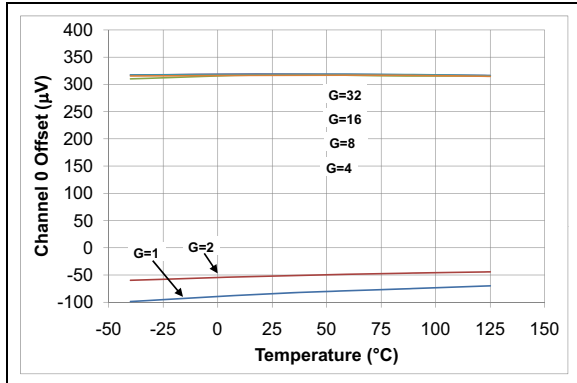
**FIGURE 2-27:** THD vs. Temperature.



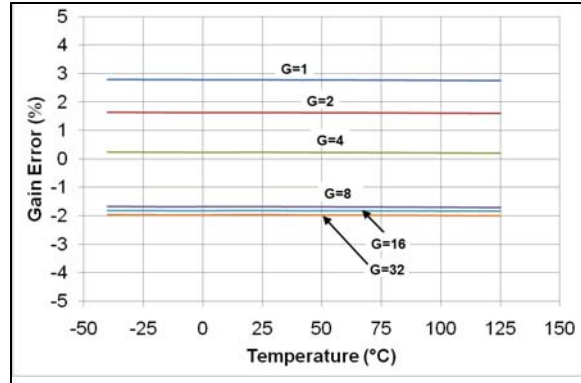
**FIGURE 2-30:** SFDR vs. Temperature.

# MCP3911

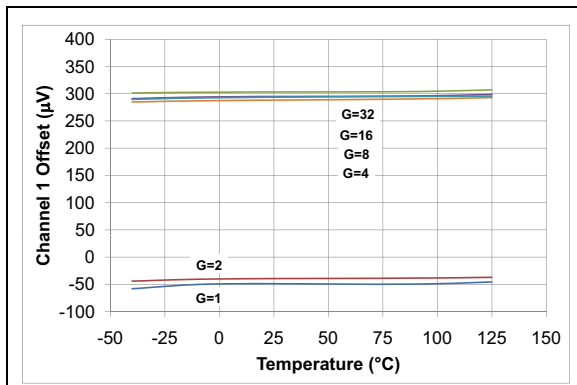
**Note:** Unless otherwise indicated,  $V_{DD} = 3.3V$ ,  $DV_{DD} = 3.3V$ ;  $T_A = 25^\circ C$ , MCLK = 4 MHz; PRESCALE = 1; OSR = 256; GAIN = 1; Dithering = Maximum;  $V_{IN} = -0.5 \text{ dBFS @ } 60 \text{ Hz}$ , VREFEXT = 0; CLKEXT = 1, AZ\_FREQ = 0; BOOST = 1X.



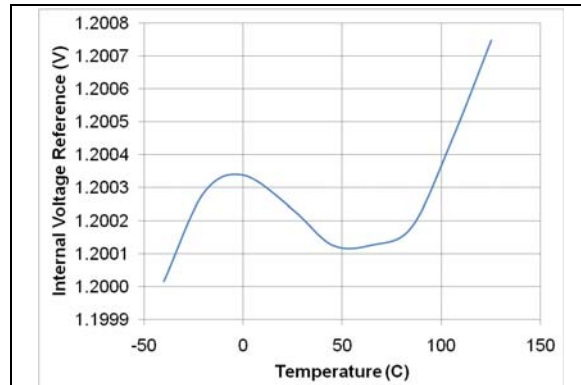
**FIGURE 2-31:** Channel 0 Offset vs. Temperature.



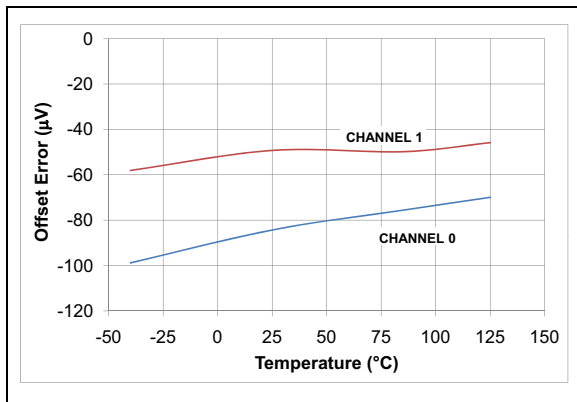
**FIGURE 2-34:** Gain Error vs. Temperature.



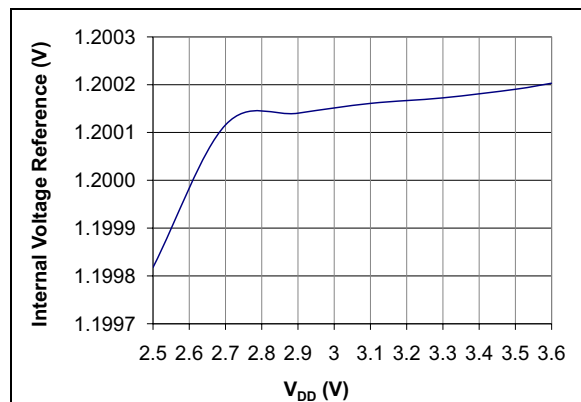
**FIGURE 2-32:** Channel 1 Offset vs. Temperature.



**FIGURE 2-35:** Internal Voltage Reference vs. Temperature.



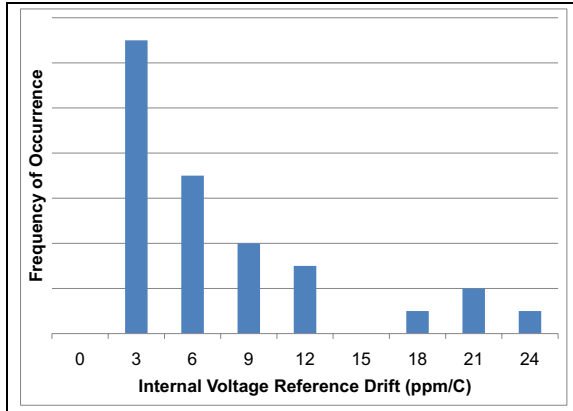
**FIGURE 2-33:** Channel to Channel Offset Match vs. Temperature.



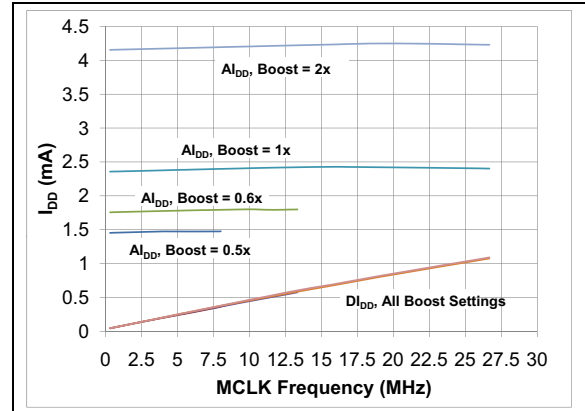
**FIGURE 2-36:** Internal Voltage Reference vs. Supply Voltage.



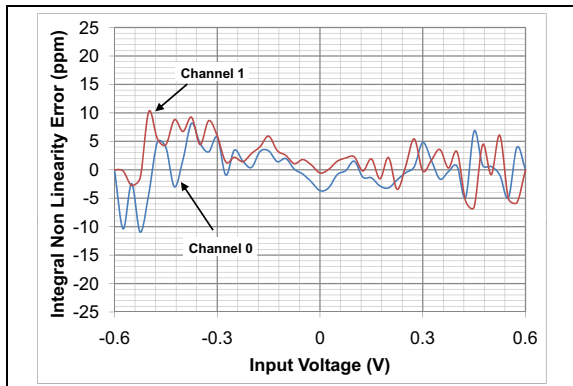
**Note:** Unless otherwise indicated,  $V_{DD} = 3.3V$ ,  $DV_{DD} = 3.3V$ ;  $T_A = 25^\circ C$ ,  $MCLK = 4\text{ MHz}$ ;  $PRESCALE = 1$ ;  $OSR = 256$ ;  $GAIN = 1$ ;  $Dithering = \text{Maximum}$ ;  $V_{IN} = -0.5\text{ dBFS @ } 60\text{ Hz}$ ,  $V_{REFEXT} = 0$ ;  $CLKEXT = 1$ ,  $AZ\_FREQ = 0$ ;  $BOOST = 1X$ .



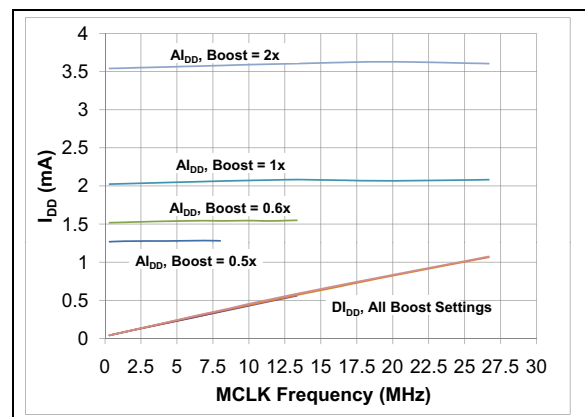
**FIGURE 2-37:**  $V_{REF}$  Drift Data Histogram Chart.



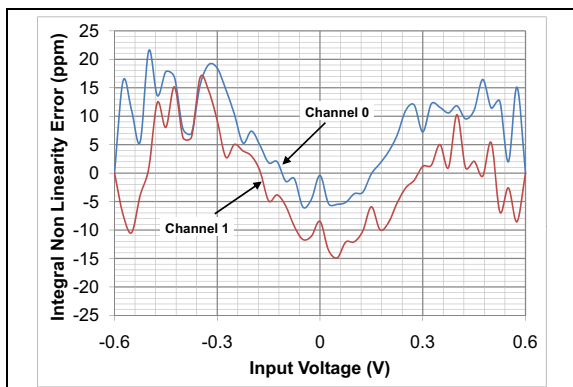
**FIGURE 2-40:** Operating Current vs. MCLK,  $V_{DD} = 3.3V$ .



**FIGURE 2-38:** Integral Non-Linearity (Dithering Maximum).



**FIGURE 2-41:** Operating Current vs. MCLK,  $V_{DD} = 2.7V$ .



**FIGURE 2-39:** Integral Non-Linearity (Dithering Off).

# MCP3911

---

NOTES:

### 3.0 PIN DESCRIPTION

The descriptions of the pins are listed in [Table 3-1](#).

**TABLE 3-1: PIN FUNCTION TABLE**

Pin No. SSOP	Pin No. QFN	Symbol	Function
1	18	$\overline{\text{RESET}}$	Master Reset Logic Input Pin
2	19	$\text{DV}_{\text{DD}}$	Digital Power Supply Pin
3	20	$\text{AV}_{\text{DD}}$	Analog Power Supply Pin
4	1	CH0+	Non-Inverting Analog Input Pin for Channel 0
5	2	CH0-	Inverting Analog Input Pin for Channel 0
6	3	CH1-	Inverting Analog Input Pin for Channel 1
7	4	CH1+	Non-Inverting Analog Input Pin for Channel 1
8	5	AGND	Analog Ground Pin, Return Path for internal analog circuitry
9	6	REFIN+/OUT	Non-Inverting Voltage Reference Input and Internal Reference Output Pin
10	7	REFIN-	Inverting Voltage Reference Input Pin
11	8	DGND	Digital Ground Pin, Return Path for internal digital circuitry
12	9	MDAT1	Modulator Data Output Pin for Channel 1
13	10	MDAT0	Modulator Data Output Pin for Channel 0
14	11	$\overline{\text{DR}}$	Data Ready Signal Output Pin
15	12	OSC1/CLKI	Oscillator Crystal Connection Pin or External Clock Input Pin
16	13	OSC2	Oscillator Crystal Connection Pin
17	14	$\overline{\text{CS}}$	Serial Interface Chip Select Pin
18	15	SCK	Serial Interface Clock Input Pin
19	16	SDO	Serial Interface Data Input Pin
20	17	SDI	Serial Interface Data Input Pin
-	21	EP	Exposed Thermal Pad. Must be connected to AGND.

#### 3.1 Master Reset ( $\overline{\text{RESET}}$ )

This pin is active low and places the entire chip in a reset state when active.

When  $\overline{\text{RESET}}=0$ , all registers are reset to their default value, no communication can take place, and no clock is distributed inside the part, except in the input structure if MCLK is applied (if idle, then no clock is distributed). This state is equivalent to a POR state.

Since the default state of the ADCs is on, the analog power consumption, when  $\overline{\text{RESET}}=0$ , is equivalent to when  $\overline{\text{RESET}}=1$ . Only the digital power consumption is largely reduced because this current consumption is essentially dynamic and is reduced drastically when there is no clock running.

All the analog biases are enabled during a reset so that the part is fully operational just after a  $\overline{\text{RESET}}$  rising edge, if the MCLK is applied during the rising edge. If not applied, there is a small time after  $\overline{\text{RESET}}$  where the conversion may not be accurate corresponding to the startup of the charge pump of the input structure.

This input is Schmitt triggered.

#### 3.2 Digital $\text{V}_{\text{DD}}$ ( $\text{DV}_{\text{DD}}$ )

$\text{DV}_{\text{DD}}$  is the power supply pin for the digital circuitry within the MCP3911. This pin requires appropriate bypass capacitors and should be maintained between 2.7V and 3.6V for specified operation.

#### 3.3 Analog $\text{V}_{\text{DD}}$ ( $\text{AV}_{\text{DD}}$ )

$\text{AV}_{\text{DD}}$  is the power supply pin for the analog circuitry within the MCP3911. This pin requires appropriate bypass capacitors and should be maintained to 2.7V and 3.6V for specified operation.

#### 3.4 ADC Differential Analog inputs ( $\text{CHn+}/\text{CHn-}$ )

CH0- and CH0+, and CH1- and CH1+, are the two fully-differential analog voltage inputs for the Delta-Sigma ADCs.

# MCP3911

The linear and specified region of the channels are dependent on the PGA gain. This region corresponds to a differential voltage range of  $\pm 600 \text{ mV}/\text{GAIN}$  with  $V_{\text{REF}}=1.2\text{V}$ .

The maximum differential voltage is proportional to the  $V_{\text{REF}}$  voltage. The maximum absolute voltage, with respect to AGND, for each CHn $\pm$  input pin is  $\pm 1\text{V}$  with no distortion and  $\pm 2\text{V}$  with no breaking after continuous voltage. This maximum absolute voltage is not proportional to the  $V_{\text{REF}}$  voltage.

## 3.5 Analog Ground (AGND)

AGND is the ground connection to internal analog circuitry (See the “[Functional block diagram](#)”). To ensure accuracy and noise cancellation, this pin must be connected to the same ground as DGND, preferably with a star connection. If an analog ground plane is available, it is recommended that this pin be tied to this plane of the PCB. This plane should also reference all other analog circuitry in the system.

## 3.6 Non-inverting Reference Input, Internal Reference Output (REFIN+/OUT)

This pin is the non-inverting side of the differential voltage reference input for both ADCs or the internal voltage reference output.

When  $V_{\text{REFEXT}}=1$ , an external voltage reference source can be used, the internal voltage reference is disabled. When using an external differential voltage reference, it should be connected to its  $V_{\text{REF+}}$  pin. When using an external single-ended reference, it should be connected to this pin.

When  $V_{\text{REFEXT}}=0$ , the internal voltage reference is enabled and connected to this pin through a switch. This voltage reference has minimal drive capability and thus needs proper buffering and bypass capacitances (a  $0.1 \mu\text{F}$  ceramic capacitor is sufficient in most cases) if used as a voltage source.

If the voltage reference is only used as an internal  $V_{\text{REF}}$ , adding bypass capacitance on REFIN+/OUT is not necessary for keeping ADC accuracy, but a minimal  $0.1 \mu\text{F}$  ceramic capacitance can be connected to avoid EMI/EMC susceptibility issues due to the antenna created by the REFIN+/OUT pin if left floating.

## 3.7 Inverting Reference Input (REFIN-)

This pin is the inverting side of the differential voltage reference input for both ADCs. When using an external differential voltage reference, it should be connected to its  $V_{\text{REF-}}$  pin. When using an external single-ended voltage reference, or when  $V_{\text{REFEXT}}=0$  (Default) and using the internal voltage reference, this pin should be directly connected to AGND.

## 3.8 Digital Ground Connection (DGND)

DGND is the ground connection to internal digital circuitry (See the MCP3911 Block diagram). To ensure optimal accuracy and noise cancellation, DGND must be connected to the same ground as AGND, preferably with a star connection. If a digital ground plane is available, it is recommended that this pin be tied to this plane of the Printed Circuit Board (PCB). This plane should also reference all other digital circuitry in the system.

## 3.9 Modulator Data Output Pin for Channel 1 and Channel 0 (MDAT1/MDAT0)

MDAT0 and MDAT1 are the output pins for the modulator serial bitstreams of ADC channels 0 and 1, respectively. These pins are high impedance when their corresponding MODOUT bit is logic low. When the MODOUT<1:0> are enabled, the modulator bitstream of the corresponding channel is present on the pin and updated at the AMCLK frequency. (See [Section 5.4 “Modulator Output Block”](#) for a complete description of the modulator outputs). These pins can be directly connected to a MCU or DSP when a specific digital filtering is needed.

## 3.10 Data Ready Output ( $\overline{\text{DR}}$ )

The data ready pin indicates if a new conversion result is ready to be read. The default state of this pin is high when  $\text{DR\_HIZ}=1$  and is high impedance when  $\text{DR\_HIZ}=0$  (Default). After each conversion is finished, a logic low pulse will take place on the data ready pin to indicate the conversion result is ready as an interrupt. This pulse is synchronous with the master clock and has a defined and constant width.

The data ready pin is independent of the SPI interface and acts like an interrupt output. The data ready pin state is not latched and the pulse width (and period) are both determined by the MCLK frequency, over-sampling rate, and internal clock pre-scale settings. The DR pulse width is equal to one DMCLK period and the frequency of the pulses is equal to DRCLK (see [Figure 1-3](#)).

**Note:** This pin should not be left floating when  $\overline{\text{DR\_HIZ}}$  bit is low; a  $100 \text{ k}\Omega$  pull-up resistor connected to  $\text{DV}_{\text{DD}}$  is recommended.

### 3.11 Oscillator And Master Clock Input Pins (OSC1/CLKI, OSC2)

OSC1/CLKI and OSC2 provide the master clock (MCLK) for the device. When CLKEXT=0, a resonant crystal or clock source with a similar sinusoidal waveform must be placed across these pins to ensure proper operation. The typical clock frequency specified is 4 MHz. For proper operation, and for optimizing ADC accuracy, AMCLK should be limited to the maximum frequency defined in the [Table 5-3](#) in function of the BOOST and PGA setting chosen. MCLK can take larger values as long as the prescaler settings (PRE<1:0>) limit AMCLK=MCLK/PRESCALE in the defined range in the [Table 5-3](#). Appropriate load capacitance should be connected to these pins for proper operation.

### 3.12 Chip Select ( $\overline{\text{CS}}$ )

This pin is the SPI chip select that enables the serial communication. When this pin is high, no communication can take place. A chip select falling edge initiates the serial communication and a chip select rising edge terminates the communication. No communication can take place even when CS is low when  $\overline{\text{RESET}}$  is low.

This input is Schmitt-triggered.

### 3.13 Serial Data Clock (SCK)

This is the serial clock pin for SPI communication.

Data is clocked into the device on the RISING edge of SCK. Data is clocked out of the device on the FALLING edge of SCK.

The MCP3911 interface is compatible with both SPI 0,0 and 1,1 modes. SPI modes can be changed during a  $\overline{\text{CS}}$  high time.

The maximum clock speed specified is 20 MHz.

This input is Schmitt triggered.

### 3.14 Serial Data Output (SDO)

This is the SPI data output pin. Data is clocked out of the device on the FALLING edge of SCK.

This pin stays high impedance during the first command byte. It also stays high impedance during the whole communication for write commands and when  $\overline{\text{CS}}$  pin is high or when  $\overline{\text{RESET}}$  pin is low. This pin is active only when a read command is processed. Each read is processed by packet of 8 bits.

### 3.15 Serial Data Input (SDI)

This is the SPI data input pin. Data is clocked into the device on the RISING edge of SCK.

When  $\overline{\text{CS}}$  is low, this pin is used to communicate with a series of 8-bit commands.

The interface is half-duplex (inputs and outputs do not happen at the same time).

Each communication starts with a chip select falling edge followed by an 8-bit command word entered through the SDI pin. Each command is either a Read or a Write command. Toggling SDI during a Read command has no effect.

This input is Schmitt triggered.

# MCP3911

---

NOTES:

## 4.0 TERMINOLOGY AND FORMULAS

This section defines the terms and formulas used throughout this data sheet. The following terms are defined:

- MCLK - Master Clock
- AMCLK - Analog Master Clock
- DMCLK - Digital Master Clock
- DRCLK - Data Rate Clock
- OSR - Oversampling Ratio
- Offset Error
- Gain Error
- Integral Non-Linearity Error
- Signal-To-Noise Ratio (SNR)
- Signal-To-Noise Ratio And Distortion (SINAD)
- Total Harmonic Distortion (THD)
- Spurious-Free Dynamic Range (SFDR)
- MCP3911 Delta-Sigma Architecture
- Idle Tones
- Dithering
- Crosstalk
- PSRR
- CMRR
- ADC Reset Mode
- Hard Reset Mode (RESET = 0)
- ADC Shutdown Mode
- Full Shutdown Mode

## 4.1 MCLK - Master Clock

This is the fastest clock present in the device. This is the frequency of the crystal placed at the OSC1/OSC2 inputs when CLKEXT=0 or the frequency of the clock input at the OSC1/CLKI when CLKEXT=1. See Figure 4-1.

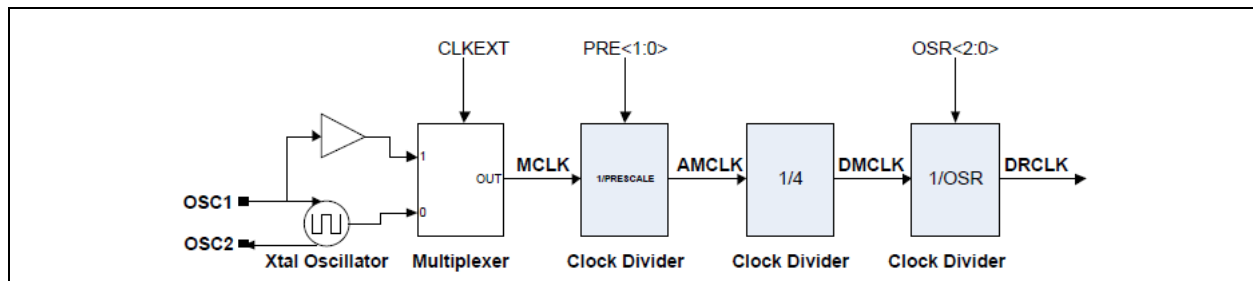
## 4.2 AMCLK - Analog Master Clock

This is the clock frequency that is present on the analog portion of the device, after prescaling has occurred via the CONFIG PRE<1:0> register bits. The analog portion includes the PGAs and the two Delta-Sigma modulators.

$$AMCLK = \frac{MCLK}{PRESCALE}$$

**TABLE 4-1: MCP3911 OVERSAMPLING RATIO SETTINGS**

Config		Analog Master Clock Prescale
PRE<1:0>		
0	0	AMCLK = MCLK/ 1 (default)
0	1	AMCLK = MCLK/ 2
1	0	AMCLK = MCLK/ 4
1	1	AMCLK = MCLK/ 8



**FIGURE 4-1:** Clock Sub-circuitry.

## 4.3 DMCLK - Digital Master Clock

This is the clock frequency that is present on the digital portion of the device, after prescaling and division by 4. This is also the sampling frequency, that is the rate at which the modulator outputs are refreshed. Each period of this clock corresponds to one sample and one modulator output. See Figure 4-1.

**EQUATION 4-1:**

$$DMCLK = \frac{AMCLK}{4} = \frac{MCLK}{4 \times PRESCALE}$$

## 4.4 DRCLK - Data Rate Clock

This is the output data rate, i.e., the rate at which the ADCs output new data. Each new data is signaled by a data ready pulse on the DR pin.

This data rate is depending on the OSR and the prescaler with the following formula:

**EQUATION 4-2:**

$$DRCLK = \frac{DMCLK}{OSR} = \frac{AMCLK}{4 \times OSR} = \frac{MCLK}{4 \times OSR \times PRESCALE}$$

# MCP3911

Since this is the output data rate, and since the decimation filter is a SINC (or notch) filter, there is a notch in the filter transfer function at each integer multiple of this rate.

The following table describes the various combinations of OSR and PRESCALE and their associated AMCLK, DMCLK and DRCLK rates.

**TABLE 4-2: DEVICE DATA RATES IN FUNCTION OF MCLK, OSR, AND PRESCALE, MCLK=4MHZ**

PRE <1:0>		OSR <2:0>			OSR	AMCLK	DMCLK	DRCLK	DRCLK (ksp/s)	SINAD (dB) Note 1	ENOB from SINAD (bits) Note 1
1	1	1	1	1	4096	MCLK/8	MCLK/32	MCLK/131072	0.035	98	16
1	1	1	1	1	2048	MCLK/8	MCLK/32	MCLK/65536	0.061	98	16
1	1	1	1	1	1024	MCLK/8	MCLK/32	MCLK/32768	0.122	97	15.8
1	1	1	1	1	512	MCLK/8	MCLK/32	MCLK/16384	0.244	96	15.6
1	1	0	1	1	256	MCLK/8	MCLK/32	MCLK/8192	0.488	95	15.5
1	1	0	1	0	128	MCLK/8	MCLK/32	MCLK/4096	0.976	90	14.7
1	1	0	0	1	64	MCLK/8	MCLK/32	MCLK/2048	1.95	83	13.5
1	1	0	0	0	32	MCLK/8	MCLK/32	MCLK/1024	3.9	70	11.3
1	0	1	1	1	4096	MCLK/4	MCLK/16	MCLK/65536	0.061	98	16
1	0	1	1	1	2048	MCLK/4	MCLK/16	MCLK/32768	0.122	98	16
1	0	1	1	1	1024	MCLK/4	MCLK/16	MCLK/16384	0.244	97	15.8
1	0	1	1	1	512	MCLK/4	MCLK/16	MCLK/8192	0.488	96	15.6
1	0	0	1	1	256	MCLK/4	MCLK/16	MCLK/4096	0.976	95	15.5
1	0	0	1	0	128	MCLK/4	MCLK/16	MCLK/2048	1.95	90	14.7
1	0	0	0	1	64	MCLK/4	MCLK/16	MCLK/1024	3.9	83	13.5
1	0	0	0	0	32	MCLK/4	MCLK/16	MCLK/512	7.8125	70	11.3
0	1	1	1	1	4096	MCLK/2	MCLK/8	MCLK/32768	0.122	98	16
0	1	1	1	1	2048	MCLK/2	MCLK/8	MCLK/16384	0.244	98	16
0	1	1	1	1	1024	MCLK/2	MCLK/8	MCLK/8192	0.488	97	15.8
0	1	1	1	1	512	MCLK/2	MCLK/8	MCLK/4096	0.976	96	15.6
0	1	0	1	1	256	MCLK/2	MCLK/8	MCLK/2048	1.95	95	15.5
0	1	0	1	0	128	MCLK/2	MCLK/8	MCLK/1024	3.9	90	14.7
0	1	0	0	1	64	MCLK/2	MCLK/8	MCLK/512	7.8125	83	13.5
0	1	0	0	0	32	MCLK/2	MCLK/8	MCLK/256	15.625	70	11.3
0	0	1	1	1	4096	MCLK	MCLK/4	MCLK/16384	0.244	98	16
0	0	1	1	0	2048	MCLK	MCLK/4	MCLK/8192	0.488	98	16
0	0	1	0	1	1024	MCLK	MCLK/4	MCLK/4096	0.976	97	15.8
0	0	1	0	0	512	MCLK	MCLK/4	MCLK/2048	1.95	96	15.6
0	0	0	1	1	256	MCLK	MCLK/4	MCLK/1024	3.9	95	15.5
0	0	0	1	0	128	MCLK	MCLK/4	MCLK/512	7.8125	90	14.7
0	0	0	0	1	64	MCLK	MCLK/4	MCLK/256	15.625	83	13.5
0	0	0	0	0	32	MCLK	MCLK/4	MCLK/128	31.25	70	11.3

**Note 1:** For OSR = 32 and 64, DITHER = None. For OSR = 128 and higher, DITHER = Maximum. The SINAD values are given from GAIN = 1.



## 4.5 OSR - Oversampling Ratio

This is the ratio of the sampling frequency to the output data rate.  $OSR = DMCLK/DRCLK$ . The default OSR is 256, or with  $MCLK = 4\text{ MHz}$ ,  $PRESCALE = 1$ ,  $AMCLK = 4\text{ MHz}$ ,  $f_S = 1\text{ MHz}$ ,  $f_D = 3.90625\text{ ksp}$ s. The following bits in the CONFIG register are used to change the oversampling ratio (OSR).

**TABLE 4-3: MCP3911 OVERSAMPLING RATIO SETTINGS**

CONFIG			OVER SAMPLING RATIO OSR
OSR<2:0>			
0	0	0	32
0	0	1	64
0	1	0	128
0	1	1	256 (DEFAULT)
1	0	0	512
1	0	1	1024
1	1	0	2048
1	1	1	4096

## 4.6 Offset Error

This is the error induced by the ADC when the inputs are shorted together ( $V_{IN} = 0V$ ). The specification incorporates both PGA and ADC offset contributions. This error varies with PGA and OSR settings. The offset is different on each channel and varies from chip to chip. The offset is specified in  $\mu V$ . The offset error can be digitally compensated independently on each channel through the OFFCAL registers with a 24-bit calibration word.

The offset on the MCP3911 has a low temperature coefficient, see typical performance curves for more information, [Figure 2-33](#).

## 4.7 Gain Error

This is the error induced by the ADC on the slope of the transfer function. It is the deviation expressed in % compared to the ideal transfer function defined by [Equation 5-3](#). The specification incorporates both PGA and ADC gain error contributions, but not the  $V_{REF}$  contribution (it is measured with an external  $V_{REF}$ ).

This error varies with PGA and OSR settings. The gain error can be digitally compensated independently on each channel through the GAINCAL registers with a 24-bit calibration word.

The gain error on the MCP3911 has a low temperature coefficient; for more information, see [Figure 2-34](#).

## 4.8 Integral Non-Linearity Error

Integral non-linearity error is the maximum deviation of an ADC transition point from the corresponding point of an ideal transfer function, with the offset and gain errors removed, or with the end points equal to zero.

It is the maximum remaining error after calibration of offset and gain errors for a DC input signal.

## 4.9 Signal-To-Noise Ratio (SNR)

For the MCP3911 ADCs, the signal-to-noise ratio is a ratio of the output fundamental signal power to the noise power (not including the harmonics of the signal), when the input is a sine wave at a predetermined frequency. It is measured in dB. Usually, only the maximum signal to noise ratio is specified. The SNR figure depends mainly on the OSR and DITHER settings of the device.

**EQUATION 4-3: SIGNAL-TO-NOISE RATIO**

$$SNR(dB) = 10\log\left(\frac{SignalPower}{NoisePower}\right)$$

## 4.10 Signal-To-Noise Ratio And Distortion (SINAD)

The most important figure of merit for the analog performance of the ADCs present on the MCP3911 is the Signal-to-Noise And Distortion (SINAD) specification.

Signal-to-noise and distortion ratio is similar to signal-to-noise ratio, with the exception that you must include the harmonics power in the noise power calculation. The SINAD specification depends mainly on the OSR and DITHER settings.

**EQUATION 4-4: SINAD EQUATION**

$$SINAD(dB) = 10\log\left(\frac{SignalPower}{Noise + HarmonicsPower}\right)$$

The calculated combination of SNR and THD per the following formula also yields SINAD:

**EQUATION 4-5: SINAD, THD, AND SNR RELATIONSHIP**

$$SINAD(dB) = 10\log\left[10^{\left(\frac{SNR}{10}\right)} + 10^{\left(\frac{-THD}{10}\right)}\right]$$

# MCP3911

## 4.11 Total Harmonic Distortion (THD)

The total harmonic distortion is the ratio of the output harmonics power to the fundamental signal power for a sine wave input and is defined by the following equation.

### EQUATION 4-6:

$$THD(dB) = 10 \log \left( \frac{\text{Harmonics Power}}{\text{Fundamental Power}} \right)$$

The THD calculation includes the first 35 harmonics for the MCP3911 specifications. The THD is usually only measured with respect to the 10 first harmonics. THD is sometimes expressed in %. For converting the THD in %, here is the formula:

### EQUATION 4-7:

$$THD(\%) = 100 \times 10^{\frac{THD(dB)}{20}}$$

This specification depends mainly on the DITHER setting.

## 4.12 Spurious-Free Dynamic Range (SFDR)

The ratio between the output power of the fundamental and the highest spur in the frequency spectrum. The spur frequency is not necessarily a harmonic of the fundamental even though it is usually the case. This figure represents the dynamic range of the ADC when a full-scale signal is used at the input. This specification depends mainly on the DITHER setting.

### EQUATION 4-8:

$$SFDR(dB) = 10 \log \left( \frac{\text{Fundamental Power}}{\text{Highest Spur Power}} \right)$$

## 4.13 MCP3911 Delta-Sigma Architecture

The MCP3911 incorporates two Delta-Sigma ADCs with a multi-bit architecture. A Delta-Sigma ADC is an oversampling converter that incorporates a built-in modulator which is digitizing the quantity of charge integrated by the modulator loop (see [Figure 5-1](#)). The quantizer is the block that is performing the analog-to-digital conversion. The quantizer is typically 1-bit, or a simple comparator which helps to maintain the linearity performance of the ADC (the DAC structure is, in this case, inherently linear).

Multi-bit quantizers help to lower the quantization error (the error fed back in the loop can be very large with 1-bit quantizers) without changing the order of the

modulator or the OSR which leads to better SNR figures. However, typically, the linearity of such architectures is more difficult to achieve since the DAC is no more simple to realize and its linearity limits the THD of such ADCs.

The MCP3911's 5-level quantizer is a flash ADC composed of four comparators arranged with equally spaced thresholds and a thermometer coding. The MCP3911 also includes proprietary 5-level DAC architecture that is inherently linear for improved THD figures.

## 4.14 Idle Tones

A Delta-Sigma converter is an integrating converter. It also has a finite quantization step (LSB) which can be detected by its quantizer. A DC input voltage that is below the quantization step should only provide an all zeros result since the input is not large enough to be detected. As an integrating device, any Delta-Sigma will show in this case idle tones. This means that the output will have spurs in the frequency content that are depending on the ratio between quantization step voltage and the input voltage. These spurs are the result of the integrated sub-quantization step inputs that will eventually cross the quantization steps after a long enough integration. This will induce an AC frequency at the output of the ADC and can be shown in the ADC output spectrum.

These idle tones are residues that are inherent to the quantization process and the fact that the converter is integrating at all times without being reset. They are residues of the finite resolution of the conversion process. They are very difficult to attenuate and they are heavily signal dependent. They can degrade both SFDR and THD of the converter, even for DC inputs. They can be localized in the baseband of the converter and thus difficult to filter from the actual input signal.

For power metering applications, idle tones can be very disturbing because energy can be detected even at the 50 or 60 Hz frequency, depending on the DC offset of the ADCs, while no power is really present at the inputs. The only practical way to suppress or attenuate idle tones phenomenon is to apply dithering to the ADC. The idle tones amplitudes are a function of the order of the modulator, the OSR and the number of levels in the quantizer of the modulator. A higher order, a higher OSR or a higher number of levels for the quantizer will attenuate the idle tones amplitude.

## 4.15 Dithering

In order to suppress, or attenuate, the idle tones present in any Delta-Sigma ADCs, dithering can be applied to the ADC. Dithering is the process of adding an error to the ADC feedback loop in order to “decorrelate” the outputs and “break” the idle tones behavior. Usually a random or pseudo-random generator adds an analog or digital error to the feedback loop of the Delta-Sigma ADC in order to ensure that no tonal behavior can happen at its outputs. This error is filter by the feedback loop and typically has a zero average value so that the converter static transfer function is not disturbed by the dithering process. However, the dithering process slightly increases the noise floor (it adds noise to the part) while reducing its tonal behavior and thus improving SFDR and THD. (See [Figure 2-14](#) and [Figure 2-18](#)). The dithering process scrambles the idle tones into baseband white noise and ensures that dynamic specs (SNR, SINAD, THD, SFDR) are less signal dependent. The MCP3911 incorporates a proprietary dithering algorithm on both ADCs in order to remove idle tones and improve THD, which is crucial for power metering applications.

## 4.16 Crosstalk

The crosstalk is defined as the perturbation caused by one ADC channel on the other ADC channel. It is a measurement of the isolation between the two ADCs present in the chip.

This measurement is a two-step procedure:

1. Measure one ADC input with no perturbation on the other ADC (ADC inputs shorted).
2. Measure the same ADC input with a perturbation sine wave signal on the other ADC at a certain predefined frequency.

The crosstalk is then the ratio between the output power of the ADC when the perturbation is present and when it is not divided by the power of the perturbation signal.

A lower crosstalk value implies more independence and isolation between the two channels.

The measurement of this signal is performed under the default conditions at MCLK = 4 MHz:

- GAIN = 1,
- PRESCALE = 1,
- OSR = 256,
- MCLK = 4 MHz

### Step 1

- CH0+=CH0-=AGND
- CH1+=CH1-=AGND

### Step 2

- CH0+=CH0-=AGND
- CH1+ - CH1-=1.2V<sub>P-P</sub> @ 50/60 Hz (Full-scale sine wave)

The crosstalk is then calculated with the following formula:

#### EQUATION 4-9:

$$CTalk(dB) = 10\log\left(\frac{\Delta CH0Power}{\Delta CH1Power}\right)$$

## 4.17 PSRR

This is the ratio between a change in the power supply voltage and the ADC output codes. It measures the influence of the power supply voltage on the ADC outputs.

The PSRR specification can be DC (the power supply is taking multiple DC values) or AC (the power supply is a sinewave at a certain frequency with a certain common mode). In AC, the amplitude of the sinewave is representing the change in the power supply.

It is defined as:

#### EQUATION 4-10:

$$PSRR(dB) = 20\log\left(\frac{\Delta V_{OUT}}{\Delta V_{DD}}\right)$$

Where V<sub>OUT</sub> is the equivalent input voltage that the output code translates to with the ADC transfer function. In the MCP3911 specification, AV<sub>DD</sub> varies from 2.7V to 3.6V, and for AC PSRR a 50/60 Hz sinewave is chosen centered around 3.3V with a maximum 300 mV amplitude. The PSRR specification is measured with AV<sub>DD</sub> = DV<sub>DD</sub>.

## 4.18 CMRR

This is the ratio between a change in the common-mode input voltage and the ADC output codes. It measures the influence of the common-mode input voltage on the ADC outputs.

The CMRR specification can be DC (the common-mode input voltage is taking multiple DC values) or AC (the common-mode input voltage is a sinewave at a certain frequency with a certain common mode). In AC, the amplitude of the sinewave is representing the change in the power supply.

It is defined as:

## EQUATION 4-11:

$$CMRR(dB) = 20\log\left(\frac{\Delta V_{OUT}}{\Delta V_{CM}}\right)$$

Where  $V_{CM} = (CH_n+ + CH_n-)/2$  is the common-mode input voltage and  $V_{OUT}$  is the equivalent input voltage that the output code translates to with the ADC transfer function. In the MCP3911 specification,  $V_{CM}$  varies from -1V to +1V.

### 4.19 ADC Reset Mode

ADC Reset mode (called also soft reset mode) can only be entered through setting high the RESET<1:0> bits in the configuration register. This mode is defined as the condition where the converters are active but their output is forced to 0.

The registers are not affected in this reset mode and retain their except the data registers of the corresponding channel which are reset to 0.

The ADCs can immediately output meaningful codes after leaving reset mode (and after the sinc filter settling time). This mode is both entered and exited through setting of bits in the configuration register.

Each converter can be placed in soft reset mode independently. The configuration registers are not modified by the soft reset mode.

A data ready pulse will not be generated by any ADC while in reset mode.

Reset mode also effects the modulator output block, i.e., the MDAT pin, corresponding to the channel in reset. If enabled, it provides a bitstream corresponding to a zero output (a series of 0011 bits continuously repeated).

When an ADC exits ADC reset mode, any phase delay present before reset was entered will still be present. If one ADC was not in reset, the ADC leaving reset mode will resynchronize automatically the phase delay relative to the other ADC channel per the phase delay register block and give data ready pulses accordingly.

If an ADC is placed in Reset mode while the other is converting, it is not shutting down the internal clock. When going back out of reset, it will be resynchronized automatically with the clock that did not stop during reset.

If both ADCs are in soft reset the clock is no longer distributed to the digital core for low power operation. Once any of the ADC is back to normal operation, the clock is automatically distributed again.

However, when the two channels are in soft reset, the input structure is still clocking if MCLK is applied in order to bias properly the inputs so that no leakage current is observed. If MCLK is not applied, large analog

input leakage currents can be observed for highly negative input voltages (typically below -0.6V referred to AGND).

### 4.20 Hard Reset Mode (RESET = 0)

This mode is only available during a POR or when the RESET pin is pulled low. The RESET pin low state places the device in a hard reset mode.

In this mode all internal registers are reset to their default state.

The DC biases for the analog blocks are still active, i.e., the MCP3911 is ready to convert. However, this pin clears all conversion data in the ADCs. In this mode, the MDAT outputs are in high impedance. The comparator's outputs of both ADCs are forced to their reset state (0011). The SINC filters are all reset, as well as their double output buffers. See serial timing for minimum pulse low time, in [Section 1.0 "Electrical Characteristics"](#).

During a hard reset, no communication with the part is possible. The digital interface is maintained in a reset state.

During this state, the clock MCLK can be applied to the part in order to properly bias the input structures of both channels. If not applied, large analog input leakage currents can be observed for highly negative input signals and after removing the RESET state a certain start up time is necessary to bias the input structure properly. During this delay the ADC conversions can be inaccurate.

### 4.21 ADC Shutdown Mode

ADC shutdown mode is defined as a state where the converters and their biases are off, consuming only leakage current. When Shutdown bit is reset to 0, the analog biases will be enabled, as well as the clock and the digital circuitry. The ADC will give a data ready after the SINC filter settling time has occurred. However, since the analog biases are not completely settled at the beginning of the conversion, the sampling may not be accurate during about 1 ms (corresponding to the settling time of the biasing in worst case conditions). In order to guarantee the accuracy, the data ready pulse, coming within the delay of 1 ms + settling time of the SINC filter, should be discarded.

Each converter can be placed in shutdown mode independently. The CONFIG registers are not modified by the shutdown mode. This mode is only available through programming of the SHUTDOWN<1:0> bits the CONFIG register.

The output data is flushed to all zeros while in ADC shutdown. No data ready pulses are generated by any ADC while in ADC shutdown mode.

ADC shutdown mode also effects the modulator output block, i.e., if MDAT of the channel in shutdown mode is enabled, this pin will provide a bitstream corresponding to a zero output (series of 0011 bits continuously repeated).

When an ADC exits ADC shutdown mode, any phase delay present before shutdown was entered will still be present. If one ADC was not in shutdown, the ADC leaving shutdown mode will automatically resynchronize the phase delay, relative to the other ADC channel, per the phase delay register block and give data ready pulses accordingly.

If an ADC is placed in shutdown mode while the other is converting, it is not shutting down the internal clock. When going back out of shutdown, it will be resynchronized automatically with the clock that did not stop during reset.

If both ADCs are ADC shutdown modes, the clock is no more distributed to the digital core for low power operation. The clock is no more distributed to the input structure too. This can cause potential high analog input leakage currents at the analog inputs if the input voltage is highly negative (typically below -0.6V, referred to AGND). Once any of the ADC is back to normal operation, the clock is automatically distributed again.

## 4.22 Full Shutdown Mode

The lowest power consumption can be achieved when  $\text{SHUTDOWN}\langle 1:0 \rangle = 11$ ,  $\text{VREFEXT} = \text{CLKEXT} = 1$ . This mode is called “Full shutdown mode”, and no analog circuitry is enabled. In this mode, both  $\text{AV}_{\text{DD}}$  and  $\text{DV}_{\text{DD}}$  POR monitoring are also disabled. No clock is propagated throughout the chip. Both ADCs are in shutdown, and the internal voltage reference is disabled.

The clock is no more distributed to the input structure too. This can cause potential high analog inputs leakage currents at the analog inputs if the input voltage is highly negative (typically below -0.6V, referred to AGND).

The only circuit that remains active is the SPI interface but this circuit does not induce any static power consumption. If SCK is idle, the only current consumption comes from the leakage currents induced by the transistors and is less than 1  $\mu\text{A}$  on each power supply.

This mode can be used to power down the chip completely and avoid power consumption when there is no data to convert at the analog inputs. Any SCK or MCLK edge coming while in this mode will induce dynamic power consumption.

Once any of the SHUTDOWN, CLKEXT and VREFEXT bits return to 0, the two POR monitoring blocks are back to operation and  $\text{AV}_{\text{DD}}$  and  $\text{DV}_{\text{DD}}$  monitoring can take place.

When exiting full Shutdown mode, the device resets to its default configuration state. The Configuration bits all reset to their default value, and the ADCs reset to their initial state, requiring 3 DRCLK periods for an initial data ready pulse. Exiting full Shutdown mode is effectively identical to an internal reset or returning from a POR condition.

# MCP3911

---

NOTES:

## 5.0 DEVICE OVERVIEW

### 5.1 Analog Inputs (CHn+/-)

The MCP3911 analog inputs can be connected directly to current and voltage transducers (such as shunts, current transformers, or Rogowski coils). Each input pin is protected by specialized ESD structures that are certified to pass 4.0 kV HBM and 200V MM contact charge. These structures allow bipolar  $\pm 2V$  continuous voltage with respect to AGND, to be present at their inputs without the risk of permanent damage.

Both channels have fully differential voltage inputs for better noise performance. The absolute voltage at each pin, relative to AGND, should be maintained in the  $\pm 1V$  range during operation, in order to ensure the specified ADC accuracy. The common-mode signals should be adapted to respect both the previous conditions and the differential input voltage range. For best performance, the common-mode signals should be maintained to AGND.

**Note:** If the analog inputs are held to a potential of -0.6 to -1V, for extended periods of time, the clock MCLK must be present inside the device in order to avoid large leakage currents at the analog inputs. This is true even during the hard reset mode or the soft reset of both ADCs. However during shutdown mode of the two ADCs or POR state, the clock is not distributed inside the circuit. During these states, it is recommended to keep the analog input voltages above -0.6V referred to AGND, to avoid high analog inputs leakage currents.

### 5.2 Programmable Gain Amplifiers (PGA)

The two Programmable Gain Amplifiers (PGAs) reside at the front-end of each Delta-Sigma ADC. They have two functions: translate the common-mode of the input from AGND to an internal level between AGND and  $A_{VDD}$ , and amplify the input differential signal. The translation of the common mode does not change the differential signal but recenters the common-mode so that the input signal can be properly amplified.

The PGA block can be used to amplify very low signals, but the differential input range of the Delta-Sigma modulator must not be exceeded. The PGA is controlled by the PGA\_CHn<2:0> bits in the GAIN register. The following table represents the gain settings for the PGA:

**TABLE 5-1: PGA CONFIGURATION SETTING**

Gain PGA_CHn<2:0>			Gain (V/V)	Gain (dB)	V <sub>IN</sub> Range (V)
0	0	0	1	0	$\pm 0.6$
0	0	1	2	6	$\pm 0.3$
0	1	0	4	12	$\pm 0.15$
0	1	1	8	18	$\pm 0.075$
1	0	0	16	24	$\pm 0.0375$
1	0	1	32	30	$\pm 0.01875$

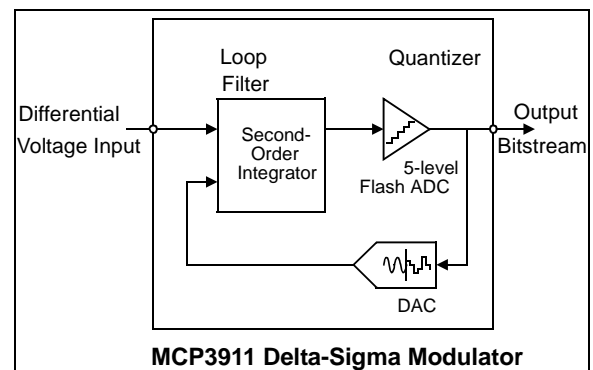
**Note:** The 2 undefined settings are G=1; this table is defined with  $V_{REF} = 1.2V$ .

### 5.3 Delta-Sigma Modulator

#### 5.3.1 ARCHITECTURE

Both ADCs are identical in the MCP3911, and they include a proprietary second-order modulator with a multi-bit 5-level DAC architecture (see Figure 5-1). The quantizer is a flash ADC composed of four comparators, with equally spaced thresholds, and a thermometer output coding. The proprietary 5-level architecture ensures minimum quantization noise at the outputs of the modulators without disturbing linearity or inducing additional distortion. The sampling frequency is DMCLK (typically 1 MHz with MCLK=4 MHz) so the modulator outputs are refreshed at a DMCLK rate. The modulator outputs are available in the MOD register or serially transferred on each MDAT pin.

Figure 5-1 represents a simplified block diagram of the Delta-Sigma ADC present on MCP3911.



**FIGURE 5-1:** Simplified Delta-Sigma ADC Block Diagram.

#### 5.3.2 MODULATOR INPUT RANGE AND SATURATION POINT

For a specified voltage reference value of 1.2V, the modulators specified differential input range is  $\pm 600$  mV. The input range is proportional to  $V_{REF}$  and scales according to the  $V_{REF}$  voltage. This range is guaranteeing the stability of the modulator over amplitude and frequency. Outside of this range, the

# MCP3911

modulator is still functional, however its stability is no longer guaranteed and therefore it is not recommended to exceed this limit (see [FIGURE 2-24: “SINAD vs. Input Signal Amplitude.”](#) for extended dynamic range performance limitations). The saturation point for the modulator is  $V_{REF}/1.5$  since the transfer function of the ADC includes a gain of 1.5 by default (independent from the PGA setting. See [Section 5.6 “ADC Output Coding”](#)).

### 5.3.3 BOOST SETTINGS

The Delta-Sigma modulators include a programmable biasing circuit in order to further adjust the power consumption to the sampling speed applied through the

MCLK. This can be programmed through the BOOST<1:0> bits which are applied to both channels simultaneously.

The maximum achievable analog master clock speed (AMCLK) and the maximum sampling frequency (DMCLK), and therefore the maximum achievable data rate (DRCLK), highly depend on BOOST<1:0> and PGA\_CHn<2:0> settings. The following table specifies the maximum AMCLK possible to keep optimal accuracy in function of BOOST<1:0> and PGA\_CHn<2:0> settings.

**TABLE 5-2: MAXIMUM AMCLK LIMITS AS A FUNCTION OF BOOST AND PGA GAIN**

Conditions		$V_{DD} = 3.0V$ to $3.6V$ , $T_A$ from $-40^{\circ}C$ to $125^{\circ}C$		$V_{DD} = 2.7V$ to $3.6V$ , $T_A$ from $-40^{\circ}C$ to $125^{\circ}C$	
Boost	Gain	Maximum AMCLK (MHz) (SINAD within -3 dB from its maximum)	Maximum AMCLK (MHz) (SINAD within -5 dB from its maximum)	Maximum AMCLK (MHz) (SINAD within -3 dB from its maximum)	Maximum AMCLK (MHz) (SINAD within -5 dB from its maximum)
0.5x	1	3	3	3	3
0.66x	1	4	4	4	4
1x	1	10	10	10	10
2x	1	16	16	16	16
0.5x	2	2.5	3	3	3
0.66x	2	4	4	4	4
1x	2	10	10	10	10
2x	2	14.5	16	13.3	14.5
0.5x	4	2.5	2.5	2.5	2.5
0.66x	4	4	4	4	4
1x	4	10	10	8	10
2x	4	13.3	16	10.7	11.4
0.5x	8	2.5	2.5	2.5	2.5
0.66x	8	4	4	4	4
1x	8	10	11.4	6.7	8
2x	8	10	14.5	8	8
0.5x	16	2	2	2	2
0.66x	16	4	4	4	4
1x	16	10.6	10.6	8	10
2x	16	12.3	16	8	10.7
0.5x	32	2	2	2	2
0.66x	32	4	4	4	4
1x	32	10	11.4	8	10
2x	32	13.3	16	8	10



## 5.3.4 AUTOZEROING FREQUENCY SETTING (AZ\_FREQ)

The MCP3911 modulators include an autozeroing algorithm to improve the offset error performance and greatly diminish 1/f noise in the ADC. This algorithm permits it to reach very high SNR and flattens the noise spectrum at the output of the ADC (see performance graphs [Figure 2-1](#), [Figure 2-2](#), [Figure 2-3](#) and [Figure 2-4](#)). This autozeroing algorithm is performed synchronously with the MCLK coming to the device, and its rate can be adjusted throughout the AZ\_FREQ bit in the CONFIG register.

When AZ\_FREQ=0 (default) the autozeroing is happening at the slowest rate, which diminishes the 1/f noise while not impacting the THD performance. This mode is recommended for low values of the PGA gain (GAIN=1x or 2x).

When AZ\_FREQ=1, the autozeroing is happening at the fastest rate, which further diminishes the 1/f noise and further improves the SNR, especially at higher gain settings. The THD may slightly be impacted in this mode (see [Figure 2-22](#)). This mode is recommended for higher PGA gain settings to improve SNR (GAIN superior or equal to 4x).

## 5.3.5 DITHER SETTINGS

Both modulators also include a dithering algorithm that can be enabled through the DITHER<1:0> bits in the configuration register. This dithering process improves THD and SFDR (for high OSR settings) while increasing slightly the noise floor of the ADCs. For power metering applications and applications that are distortion-sensitive, it is recommended to keep DITHER at maximum settings for best THD and SFDR performance. In the case of power metering applications, THD and SFDR are critical specifications. Optimizing SNR (noise floor) is not really problematic due to large averaging factor at the output of the ADCs, therefore even for low OSR settings, the dithering algorithm will show a positive impact on the performance of the application.

## 5.4 Modulator Output Block

If the user wishes to use the modulator output of the device, the appropriate bits to enable the modulator output must be set in the configuration register.

When MODOUT<1:0> bits are enabled, the modulator output of the corresponding channel is present at the corresponding MDAT output pin as soon as the command is placed. Additionally, the corresponding SINC filter is disabled in order to consume less current. The corresponding DR pulse is also not present at the DR output pin. When MODOUT<1:0> bits are cleared, the corresponding SINC filters are back to normal operation and the corresponding MDAT outputs are in high impedance.

Since the Delta-Sigma modulators have a 5-level output given by the state of four comparators with thermometer coding, their outputs can be represented on four bits, each bit giving the state of the corresponding comparator (See [Table 5-3](#)). These bits are present on the MOD register and are updated at the DMCLK rate.

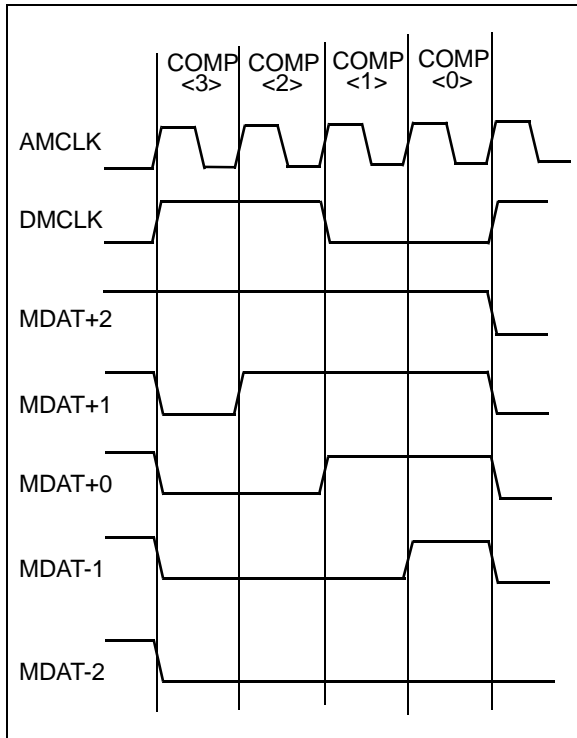
In order to output the comparators result on a separate pin (MDAT0 and MDAT1), these comparator output bits have been arranged to be serially output at the AMCLK rate (See [Figure 5-2](#)).

This 1-bit serial bitstream is the same that would be produced by a 1-bit DAC modulator with a sampling frequency of AMCLK. The modulator can either be considered like a 5 level-output at DMCLK rate, or 1-bit output at AMCLK rate. These two representations are interchangeable. The MDAT outputs can therefore be used in any application that requires 1-bit modulator outputs. These applications will often integrate and filter the 1-bit output with SINC, or more complex decimation filters computed by a MCU or a DSP.

**TABLE 5-3: DELTA-SIGMA MODULATOR CODING**

Comp<3:0> Code	Modulator Output Code	MDAT Serial Stream
1111	+2	1111
0111	+1	0111
0011	0	0011
0001	-1	0001
0000	-2	0000

# MCP3911



**FIGURE 5-2:** MDAT Serial Outputs in Function of the Modulator Output Code.

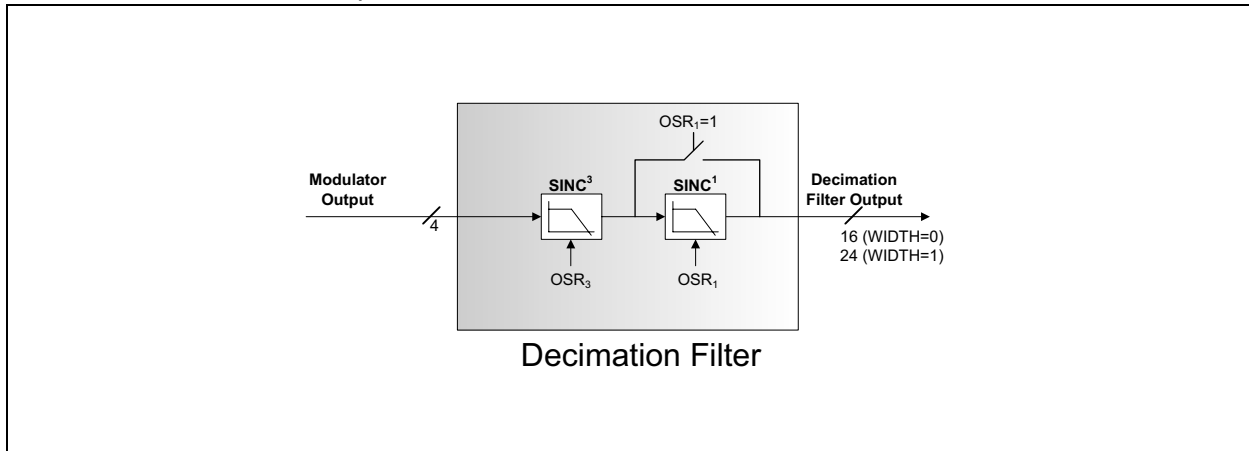
Since the reset and shutdown SPI commands are asynchronous, the MDAT pins are resynchronized with DMCLK after each time the part goes out of reset and shutdown.

This means that the first output of MDAT, after a soft reset or a shutdown, is always 0011 after the first DMCLK rising edge.

The two MDAT output pins are in high impedance if the RESET pin is low.

## 5.5 SINC<sup>3</sup> + SINC<sup>1</sup> Filter

The decimation filter present in both channels of the MCP3911 is a cascade of two sinc filters (sinc<sup>3</sup>+sinc<sup>1</sup>): a third order sinc filter with a decimation ratio of OSR<sub>3</sub> followed by first order sinc filter with a decimation ratio of OSR<sub>1</sub> (moving average of OSR<sub>1</sub> values). Figure 5-3 represents the decimation filter architecture.



**FIGURE 5-3:** MCP3911 Decimation Filter Block Diagram.

The formula for calculating the transfer function of the digital decimation filter and settling time of the ADC is as follows:

### EQUATION 5-1: SINC FILTER TRANSFER FUNCTION

$$H(z) = \frac{(1 - z^{-OSR_3})^3}{(OSR_3(1 - z^{-1}))^3} \times \frac{(1 - z^{-OSR_1 \times OSR_3})}{OSR_1 \times (1 - z^{-OSR_3})}, \text{ where}$$

$$z = EXP(2\pi \cdot j \cdot f_{in} / DMCLK)$$

## EQUATION 5-2: SETTLING TIME OF THE ADC AS A FUNCTION OF DMCLK PERIODS

$$SettlingTime(DMCLKPeriods) = 3 \times OSR_3 + (OSR_1 - 1) \times OSR_3$$

The SINC<sup>1</sup> filter following the SINC<sup>3</sup> filter is only enabled for the high OSR settings. This SINC<sup>1</sup> filter provides additional rejection at a low cost with little modification to the -3 dB bandwidth. For 24-Bit Output mode (WIDTH = 1), the output of the sinc filter is padded on the right with least significant zeros, up to 24 bits, for any resolution less than 24 bits. For 16-Bit Output modes, the output of the sinc filter is rounded to the closest 16-bit number, in order to conserve only 16-bit words and to minimize truncation error.

The gain of the transfer function of this filter is 1 at each multiple of DMCLK (typically 1 MHz) so a proper anti-aliasing filter must be placed at the inputs. This will attenuate the frequency content around DMCLK and keep the desired accuracy over the baseband of the converter. This anti-aliasing filter can be a simple, first-order RC network with a sufficiently low time constant to generate high rejection at DMCLK frequency.

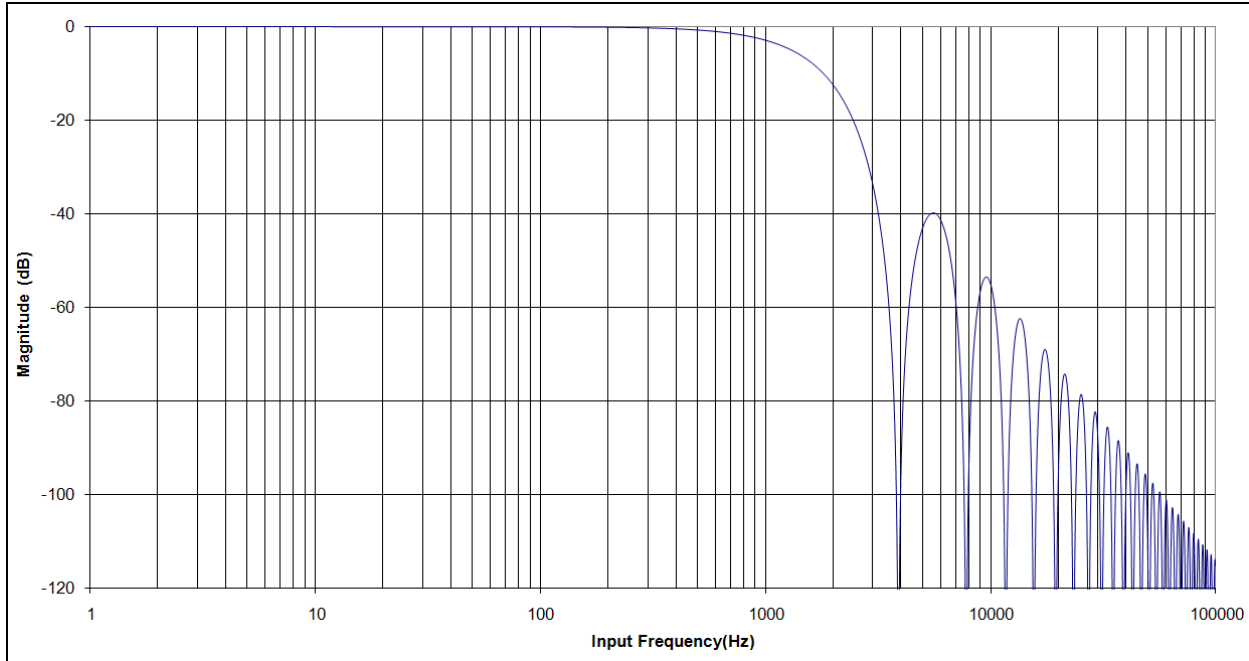
Any unsettled data is automatically discarded to avoid data corruption. Each data ready pulse corresponds to fully settled data at the output of the decimation filter. The first data available at the output of the decimation filter is present after the complete settling time of the filter (see Table 5-4). After the first data has been processed, the delay between two data ready pulses is 1/DRCLK. The data stream from input to output is delayed by an amount equal to the settling time of the filter (which is the group delay of the filter).

The achievable resolution, the -3 dB bandwidth and the settling time at the output of the decimation filter (the output of the ADC), is dependent on the OSR of each sinc filter and is summarized with the following table:

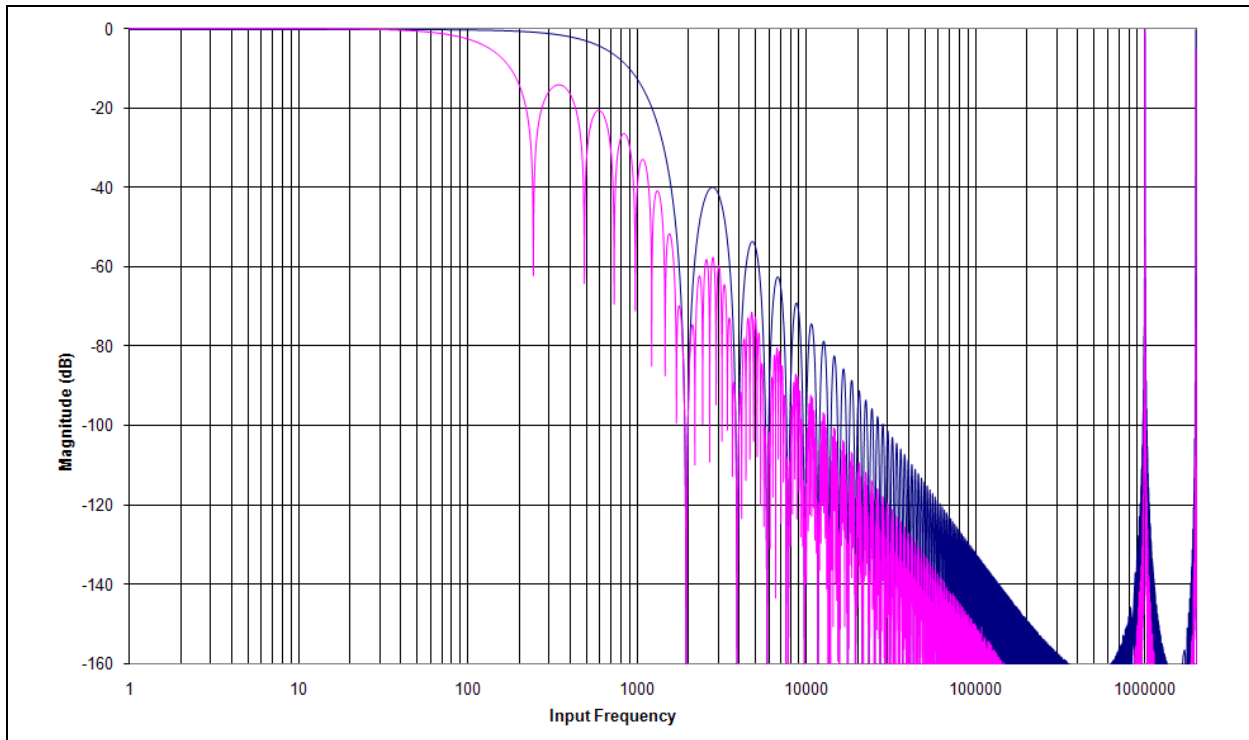
**TABLE 5-4: OVERSAMPLING RATIO AND SINC FILTER SETTLING TIME**

OSR<2:0>			OSR <sub>3</sub>	OSR <sub>1</sub>	TOTAL OSR	RESOLUTION IN BITS (NO MISSING CODES)	SETTLING TIME	-3 dB BANDWIDTH
0	0	0	32	1	32	17	96/DMCLK	0.26*DRCLK
0	0	1	64	1	64	20	192/DMCLK	0.26*DRCLK
0	1	0	128	1	128	23	384/DMCLK	0.26*DRCLK
0	1	1	256	1	256	24	768/DMCLK	0.26*DRCLK
1	0	0	512	1	512	24	1536/DMCLK	0.26*DRCLK
1	0	1	512	2	1024	24	2048/DMCLK	0.37*DRCLK
1	1	0	512	4	2048	24	3072/DMCLK	0.42*DRCLK
1	1	1	512	8	4096	24	5120/DMCLK	0.43*DRCLK

# MCP3911



**FIGURE 5-4:** SINC Filter Frequency Response, OSR = 256, MCLK = 4 MHz, PRE<1:0> = 00.



**FIGURE 5-5:** SINC Filter Frequency Response, OSR = 4096 (pink), OSR = 512 (blue), MCLK = 4 MHz, PRE<1:0> = 00.

## 5.6 ADC Output Coding

The second order modulator, SINC<sup>3</sup>+SINC<sup>1</sup> filter, PGA, V<sub>REF</sub> and analog input structure, all work together to produce the device transfer function for the analog to digital conversion, [Equation 5-3](#).

The channel data is either a 16-bit or 24-bit word, presented in 23-bit or 15-bit plus sign, two's complement format and is MSB (left) justified.

The ADC data is two or three bytes wide depending on the WIDTH bit of the associated channel. The 16-bit mode includes a round to the closest 16-bit word (instead of truncation), in order to improve the accuracy of the ADC data.

In case of positive saturation (CH<sub>n+</sub> - CH<sub>n-</sub> > V<sub>REF</sub>/1.5), the output is locked to 7FFFFFF for 24 bit mode (7FFF for 16 bit mode). In case of negative saturation (CH<sub>n+</sub> - CH<sub>n-</sub> < -V<sub>REF</sub>/1.5), the output code is locked to 800000 for 24-bit mode (8000 for 16 bit mode).

[Equation 5-3](#) is only true for DC inputs. For AC inputs, this transfer function needs to be multiplied by the transfer function of the SINC<sup>3</sup>+SINC<sup>1</sup> filter (see [Equation 5-1](#) and [Equation 5-3](#)).

### EQUATION 5-3:

$$DATA\_CHn = \left( \frac{CH_{n+} - CH_{n-}}{V_{REF+} - V_{REF-}} \right) \times 8,388,608 \times G \times 1.5 \quad (\text{For 24-bit Mode Or WIDTH} = 1)$$

$$DATA\_CHn = \left( \frac{CH_{n+} - CH_{n-}}{V_{REF+} - V_{REF-}} \right) \times 32,768 \times G \times 1.5 \quad (\text{For 16-bit Mode Or WIDTH} = 0)$$

The ADC resolution is a function of the OSR ([Section 5.5 "SINC3 + SINC1 Filter"](#)). The resolution is the same for both channels. No matter what the resolution is, the ADC output data is always presented in 24-bit words, with added zeros at the end, if the OSR is not large enough to produce 24-bit resolution (left justification).

**TABLE 5-5: OSR = 256 (AND HIGHER) OUTPUT CODE EXAMPLES**

ADC Output Code (MSB First)	Hexadecimal	Decimal, 24-bit Resolution
0 1	0x7FFFFFFF	+ 8,388,607
0 1 0	0x7FFFFFFE	+ 8,388,606
0 0	0x000000	0
1 1	0xFFFFFFFF	-1
1 0 1	0x800001	- 8,388,607
1 0	0x800000	- 8,388,608

**TABLE 5-6: OSR = 128 OUTPUT CODE EXAMPLES**

ADC Output Code (MSB First)	Hexadecimal	Decimal 23-bit Resolution
0 1 1 1 1 1 1 1 1 1 1 1 1 1 1 1 1 0	0x7FFFFFFE	+ 4,194,303
0 1 1 1 1 1 1 1 1 1 1 1 1 0 1 1 1 1 1 1 0	0x7FFFFFFC	+ 4,194,302
0 0	0x000000	0
1 1 1 1 1 1 1 1 1 1 1 1 1 1 1 1 1 1 0	0xFFFFFFFF	-1
1 0 0 0 0 0 0 0 0 0 0 0 0 0 0 0 0 0 1 0	0x800002	- 4,194,303
1 0 0 0 0 0 0 0 0 0 0 0 0 0 0 0 0 0 0 0	0x800000	- 4,194,304

# MCP3911

**TABLE 5-7: OSR = 64 OUTPUT CODE EXAMPLES**

ADC Output code (MSB First)	Hexadecimal	Decimal 20-bit resolution
0 1 1 1 1 1 1 1 1 1 1 1 1 1 1 1 0 0 0 0	0x7FFFF0	+ 524, 287
0 1 1 1 1 1 1 1 1 1 1 1 1 1 1 0 0 0 0 0	0x7FFFE0	+ 524, 286
0 0 0 0 0 0 0 0 0 0 0 0 0 0 0 0 0 0 0 0	0x000000	0
1 1 1 1 1 1 1 1 1 1 1 1 1 1 1 1 0 0 0 0	0xFFFFF0	-1
1 0 0 0 0 0 0 0 0 0 0 0 0 0 0 0 1 0 0 0 0	0x800010	- 524, 287
1 0 0 0 0 0 0 0 0 0 0 0 0 0 0 0 0 0 0 0	0x800000	- 524, 288

**TABLE 5-8: OSR = 32 OUTPUT CODE EXAMPLES**

ADC Output code (MSB First)	Hexadecimal	Decimal 17-bit resolution
0 1 1 1 1 1 1 1 1 1 1 0 0 0 0 0 0 0 0 0	0x7FFF80	+ 65, 535
0 1 1 1 1 1 1 1 1 1 1 0 0 0 0 0 0 0 0 0	0x7FFF00	+ 65, 534
0 0 0 0 0 0 0 0 0 0 0 0 0 0 0 0 0 0 0 0	0x000000	0
1 1 1 1 1 1 1 1 1 1 1 0 0 0 0 0 0 0 0 0	0xFFFF80	-1
1 0 0 0 0 0 0 0 0 0 0 0 1 0 0 0 0 0 0 0	0x800080	- 65, 535
1 0 0 0 0 0 0 0 0 0 0 0 0 0 0 0 0 0 0 0	0x800000	- 65, 536

## 5.7 Voltage Reference

### 5.7.1 INTERNAL VOLTAGE REFERENCE

The MCP3911 contains an internal voltage reference source specially designed to minimize drift over temperature. In order to enable the internal voltage reference, the VREFEXT bit in the configuration register must be set to 0 (default mode). This internal  $V_{REF}$  supplies reference voltage to both channels. The typical value of this voltage reference is 1.2V  $\pm$ 2%. The internal reference has a very low typical temperature coefficient of  $\pm$ 7 ppm/ $^{\circ}$ C, allowing the output to have minimal variation with respect to temperature since they are proportional to  $(1/V_{REF})$ .

The noise of the internal voltage reference is low enough not to significantly degrade the SNR of the ADC if compared to a precision external low-noise voltage reference. The output pin for the internal voltage reference is REFIN+/OUT.

If the voltage reference is only used as an internal  $V_{REF}$ , adding bypass capacitance on REFIN+/OUT is not necessary for keeping ADC accuracy, but a minimal 0.1  $\mu$ F ceramic capacitance can be connected to avoid EMI/EMC susceptibility issues, due to the antenna created by the REFIN+/OUT pin if left floating.

The bypass capacitors also help applications where the voltage reference output is connected to other circuits. In this case, additional buffering may be needed as the output drive capability of this output is low.

Adding too much capacitance on the REFIN+/OUT pin may slightly degrade the THD performance of the ADCs.

### 5.7.2 DIFFERENTIAL EXTERNAL VOLTAGE INPUTS

When the VREFEXT bit is high, the two reference pins (REFIN+/OUT, REFIN-) become a differential voltage reference input. The internal voltage reference circuit is placed into shutdown and the switch connecting this circuit to the reference voltage input of the ADC is opened. The internal voltage reference circuit is placed into shutdown and the switch connecting this circuit to the reference voltage input of the ADC is opened. The voltage at the REFIN+/OUT is noted  $V_{REF+}$  and the voltage at the REFIN- pin is noted  $V_{REF-}$ . The differential voltage input value is given by the following equation:

**EQUATION 5-4:**

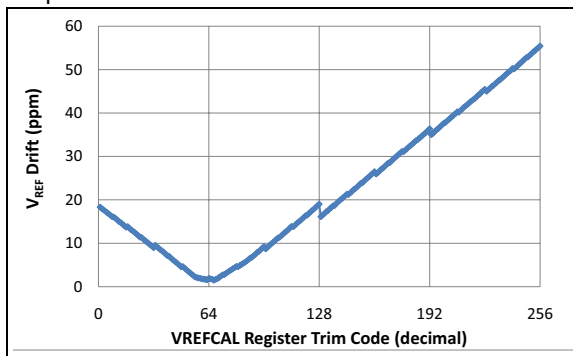
$$V_{REF} = V_{REF+} - V_{REF-}$$

The specified  $V_{REF}$  range is from 1.1V to 1.3V. The REFIN- pin voltage ( $V_{REF-}$ ) should be limited to  $\pm$ 0.1V, with respect to AGND. Typically, for single-ended reference applications, the REFIN- pin should be directly connected to AGND, with its own separate track to avoid any spike due to switching noise.

## 5.7.3 TEMPERATURE COMPENSATION (VREFCAL REGISTER)

The internal voltage reference comprises a proprietary circuit and algorithm to compensate first order and second order temperature coefficients. The compensation allows very low temperature coefficients (typically 7 ppm/°C) on the entire range of temperatures from -40°C to 125°C. This temperature coefficient varies from part to part.

This temperature coefficient can be adjusted on each part through the VREFCAL register (address 0x1A). This register is only for advanced users. This register should not be written unless the user wants to calibrate the temperature coefficient of the whole system or application. The default value of this register is set to 0x42. The typical variation of the temperature coefficient of the internal voltage reference, with respect to VREFCAL register code, is given by Figure 5-6. Modifying the value stored in the VREFCAL register may also vary the output voltage, in addition to the temperature coefficient.



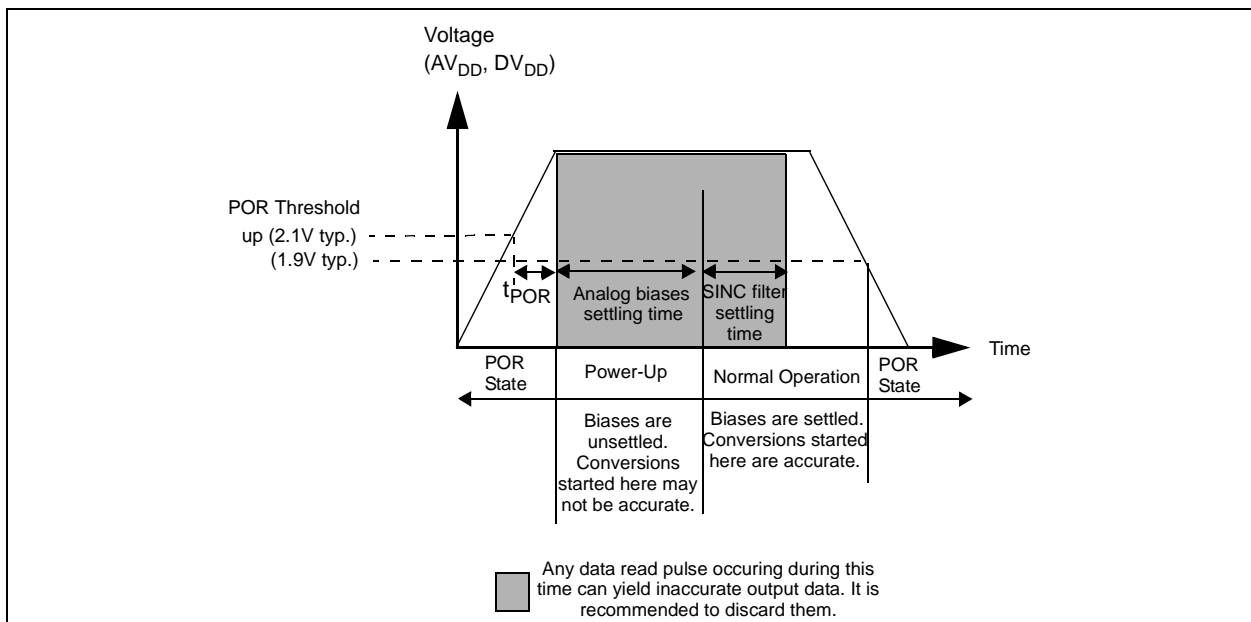
**FIGURE 5-6:**  $V_{REF}$  Tempco vs. VREFCAL Trimcode Chart.

## 5.8 Power-on Reset

The MCP3911 contains an internal POR circuit that monitors both analog and digital supply voltages during operation. The typical threshold for a power-up event detection is 2.1 V  $\pm$ 5% and a typical start-up time ( $t_{POR}$ ) of 50  $\mu$ s. The POR circuit has a built-in hysteresis for improved transient spikes immunity that has a typical value of 200 mV. Proper decoupling capacitors (0.1  $\mu$ F ceramic and 10  $\mu$ F tantalum) should be mounted as close as possible to the AV<sub>DD</sub> and DV<sub>DD</sub> pins, providing additional transient immunity.

Figure 5-7 illustrates the different conditions at power-up and a power-down event in typical conditions. All internal DC biases are not settled until at least 1 ms, in worst case conditions, after system POR. Any data ready pulse that occurs within 1 ms, plus the sinc filter settling time after system reset, should be ignored to guarantee proper accuracy. After POR, data ready pulses are present at the pin with all the default conditions in the configuration registers.

Both AV<sub>DD</sub> and DV<sub>DD</sub> are monitored so either power supply can sequence first.



**FIGURE 5-7:** Power-on Reset Operation.

## 5.9 RESET Effect On Delta-Sigma Modulator/SINC Filter

When the  $\overline{\text{RESET}}$  pin is logic low, both ADCs will be in Reset and output code 0x0000h. The  $\overline{\text{RESET}}$  pin performs a hard reset (DC biases still on, part ready to convert) and clears all charges contained in the Delta-Sigma modulators. The comparator's output is 0011 for each ADC.

The SINC filters are all reset, as well as their double output buffers. This pin is independent of the serial interface. It brings all the registers to the default state. When  $\overline{\text{RESET}}$  is logic low, any write with the SPI interface, will be disabled and will have no effect. All output pins (SDO, DR, MDAT0/1) are high impedance.

If MCLK is applied, the input structure is enabled and is properly biasing the substrate of the input transistors. In this case, the leakage current on the analog inputs is low, if the analog inputs are between -1V and +1V.

If MCLK is not applied, when in reset mode, the leakage can be high if the analog inputs are below -0.6V, referred to AGND.

## 5.10 Phase Delay Block

The MCP3911 incorporates a phase delay generator, which ensures that the two ADCs are converting the inputs with a fixed delay between them. The two ADCs are synchronously sampling but the averaging of modulator outputs is delayed, so that the SINC filter outputs (thus the ADC outputs), show a fixed phase delay, as determined by the PHASE register's setting.

The phase value (PHASE<11:0>) is a 11 bit + sign, MSB first, two's complement code that indicates how much phase delay there is to be between Channel 0 and Channel 1. The four MSB of the first phase register (address 0x07) are undefined and set to 0. The reference channel for the delay is Channel 1 (typically the voltage channel for power metering applications). When PHASE<11:0> is positive, Channel 0 is lagging versus Channel 1. When PHASE<11:0> is negative, Channel 0 is leading versus Channel 1. The amount of delay between two ADC conversions is shown in the following formula.

### EQUATION 5-5:

$$\text{Delay} = \frac{\text{Phase Register Code}}{\text{DMCLK}}$$

The timing resolution of the phase delay is 1/DMCLK, or 1  $\mu\text{s}$  in the default configuration with MCLK = 4 MHz.

The data ready signals are affected by the phase delay settings. Typically, the time difference between the data ready pulses of channel 0 and channel 1, is equal to the phase delay setting.

**Note:** A detailed explanation of the data ready pin (DR) with phase delay is [Figure 6-9](#).

### 5.10.1 PHASE DELAY LIMITS

The Phase delay can only go from -OSR/2 to +OSR/2 - 1. This sets the fine phase resolution. The phase register is coded with two's complement.

If larger delays between the two channels are needed, they can be implemented externally to the chip with an MCU. A FIFO in the MCU can save incoming data from the leading channel for a number N of DRCLK clocks. In this case, DRCLK would represent the coarse timing resolution, and DMCLK the fine timing resolution. The total delay will then be equal to:

$$\text{Delay} = N/\text{DRCLK} + \text{PHASE}/\text{DMCLK}$$

**Note:** Re-writing the PHASE registers with the same value resets and automatically restarts both ADCs.

The Phase delay register can be programmed once, with the OSR=4096 setting, and will adjust to the OSR automatically afterwards without the need to change the value of the PHASE register.

- **OSR=4096:** the delay can go from -2048 to +2047. PHASE<11> is the sign bit. Phase<10> is the MSB and PHASE<0> the LSB.
- **OSR=2048:** the delay can go from -1024 to +1023. PHASE<10> is the sign bit. Phase<9> is the MSB and PHASE<0> the LSB.
- **OSR=1024:** the delay can go from -512 to +511. PHASE<9> is the sign bit. Phase<8> is the MSB and PHASE<0> the LSB.
- **OSR=512:** the delay can go from -256 to +255. PHASE<8> is the sign bit. Phase<7> is the MSB and PHASE<0> the LSB.
- **OSR=256:** the delay can go from -128 to +127. PHASE<7> is the sign bit. Phase<6> is the MSB and PHASE<0> the LSB.
- **OSR=128:** the delay can go from -64 to +63. PHASE<6> is the sign bit. Phase<5> is the MSB and PHASE<0> the LSB.
- **OSR=64:** the delay can go from -32 to +31. PHASE<5> is the sign bit. Phase<4> is the MSB and PHASE<0> the LSB.
- **OSR=32:** the delay can go from -16 to +15. PHASE<4> is the sign bit. Phase<3> is the MSB and PHASE<0> the LSB.



**TABLE 5-9: PHASE VALUES WITH  
MCLK = 4 MHz, OSR = 4096**

Phase Register Value	Hex	Delay (CH0 relative to CH1)
0 1 1 1 1 1 1 1 1 1 1 1	0x7FF	+ 2047 $\mu$ s
0 1 1 1 1 1 1 1 1 1 1 0	0x7FE	+ 2046 $\mu$ s
0 0 0 0 0 0 0 0 0 0 0 1	0x001	+ 1 $\mu$ s
0 0 0 0 0 0 0 0 0 0 0 0	0x000	0 $\mu$ s
1 1 1 1 1 1 1 1 1 1 1 1	0xFFF	- 1 $\mu$ s
1 0 0 0 0 0 0 0 0 0 0 1	0x801	- 2048 $\mu$ s
1 0 0 0 0 0 0 0 0 0 0 0	0x800	-2048 $\mu$ s

## 5.11 Crystal Oscillator

The MCP3911 includes a Pierce-type crystal oscillator with very high stability and ensures very low tempco and jitter for the clock generation. This oscillator can handle up to 20 MHz crystal frequencies, provided that proper load capacitances and quartz quality factor are used.

For a proper start-up, the load capacitors of the crystal should be connected between OSC1 and DGND and between OSC2 and DGND. They should also respect the following equation:

**EQUATION 5-6:**

$$R_M < 1.6 \times 10^6 \times \left( \frac{1}{f \cdot C_{LOAD}} \right)^2$$

Where:

- f = crystal frequency in MHz
- C<sub>LOAD</sub> = load capacitance in pF including parasitics from the PCB
- R<sub>M</sub> = motional resistance in ohms of the quartz

**EQUATION 5-7: DIGITAL OFFSET AND GAIN ERROR CALIBRATION REGISTERS CALCULATIONS**

$$DATA\_CHn(post-cal) = (DATA\_CHn(pre-cal) + OFFCAL\_CHn) \times (1 + GAINCAL\_CHn)$$

When CLKEXT=1, the crystal oscillator is bypassed by a digital buffer to allow direct clock input for an external clock (see Figure 4-1).

When CLKEXT=1, it is recommended to connect OSC2 pin to DGND directly at all times. The external clock should not be higher than 20 MHz before prescaler (MCLK < 20 MHz) for proper operation.

**Note:** In addition to the conditions defining the maximum MCLK input frequency range, the AMCLK frequency should be maintained inferior to the maximum limits defined in Table 5-2 to guarantee the accuracy of the ADCs. If these limits are exceeded, it is recommended to either choose a larger OSR, or a large prescaler value, so that AMCLK can respect these limits.

## 5.12 Digital System Offset and Gain Errors

The MCP3911 incorporates two sets of additional registers per channel, to perform system digital offset and gain errors calibration. Each channel has its own set of registers associated that will modify the output result of the channel, if the calibration is enabled. The gain and offset calibrations can be enabled or disabled through two configuration bits (EN\_OFFCAL and EN\_GAINCAL). These two bits enable or disable system calibration on both channels at the same time. When both calibrations are enabled, the output of the ADC is modified as follows:

## 5.12.1 DIGITAL OFFSET ERROR CALIBRATION

The OFFCAL\_CHn registers are 23-bit plus sign two's complement register, which LSB value is the same as the Channel ADC Data. These two registers are then added bit-by-bit to the ADC output codes, if the EN\_OFFCAL bit is enabled. Enabling the EN\_OFFCAL bit does not create any pipeline delay, the offset addition is instantaneous. For low OSR values, only the significant digits are added to the output (up to the resolution of the ADC. For example, at OSR=32, only the 17 first bits are added).

The offset is not added when the corresponding channel is in reset or shutdown mode. The corresponding input voltage offset value added by each LSB in these 24-bit registers is:

$$\text{OFFSET}(1\text{LSB}) = V_{\text{REF}} / (\text{PGA\_CHn} * 1.5 * 8388608)$$

This register is a Don't Care if EN\_OFFCAL=0 (Offset calibration disabled), but its value is not cleared by the EN\_OFFCAL bit.

## 5.12.2 DIGITAL GAIN ERROR CALIBRATION

This register is 24-bit signed MSB first coding with a range of -1x to +0.9999999x (from 0x80000 to 0x7FFFFFFF). The gain calibration adds 1x to this register and multiplies it to the output code of the channel bit-by-bit, after offset calibration. The range of the gain calibration is thus from 0x to 1.9999999x (from 0x80000 to 0x7FFFFFFF). The LSB corresponds to a  $2^{-23}$  increment in the multiplier.

Enabling EN\_GAINCAL creates a pipeline delay of 24 DMCLK periods on both channels. All data ready pulses are delayed by 24 DMCLK periods, starting from the data ready, following the command enabling EN\_GAINCAL bit. The gain calibration is effective on the next data ready, following the command enabling EN\_GAINCAL bit.

The digital gain calibration does not function when the corresponding channel is in reset or shutdown mode. The gain multiplier value for an LSB in these 24-bit registers is:

$$\text{GAIN}(1\text{LSB}) = 1/8388608$$

This register is a Don't Care if EN\_GAINCAL=0 (Offset calibration disabled) but its value is not cleared by the EN\_GAINCAL bit.

The output data on each channel is kept to either 7FFF or 8000 (16-bit mode) or 7FFFFFFF or 800000 (24-bit mode) if the output result is out of bounds, after all calibrations are performed.

## 6.0 SERIAL INTERFACE DESCRIPTION

### 6.1 Overview

The MCP3911 device is compatible with SPI Modes 0,0 and 1,1. Data is clocked *out* of the MCP3911 on the *falling* edge of SCK and data is clocked *into* the MCP3911 on the *rising* edge of SCK. In these modes, SCK can idle either high or low.

Each SPI communication starts with a  $\overline{CS}$  falling edge and stops with the  $\overline{CS}$  rising edge. Each SPI communication is independent. When  $\overline{CS}$  is high, SDO is in high-impedance, transitions on SCK, and SDI have no effect. Additional controls:  $\overline{RESET}$ ,  $\overline{DR}$  and MDAT0/1 are also provided on separate pins for advanced communication.

The MCP3911 interface has a simple command structure. The first byte transmitted is always the CONTROL byte and is followed by data bytes that are 8-bits wide. Both ADCs are continuously converting data by default and can be reset or shut down through a CONFIG register setting.

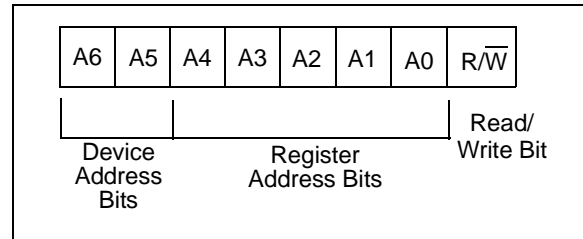
Since each ADC data is either 16 or 24 bits (depending on the WIDTH bits), the internal registers can be grouped together with various configurations (through the READ bits) in order to allow easy data retrieval within only one communication. For device reads, the internal address counter can be automatically incremented in order to loop through groups of data within the register map. The SDO will then output the data located at the ADDRESS (A<4:0>) defined in the control byte and then ADDRESS + 1 depending on the READ<1:0> bits, which select the groups of registers. These groups are defined in [Section 7.1 “CHANNEL REGISTERS - ADC Channel Data Output Registers”](#) (Register Map).

The Data Ready pin ( $\overline{DR}$ ) can be used as an interrupt for an MCU and outputs pulses when a new ADC channel data is available. The  $\overline{RESET}$  pin acts like a Hard Reset and can reset the part to its default power-up configuration. The MDAT0/1 pins give the modulator outputs (see [Section 5.4 “Modulator Output Block”](#)).

### 6.2 Control Byte

The control byte of the MCP3911 contains two device Address bits, A<6:5>, 5 register Address bits, A<4:0>, and a Read/Write bit (R/W). The first byte transmitted to the MCP3911 is always the control byte.

The MCP3911 interface is device addressable (through A<6:5>) so that multiple MCP3911 chips can be present on the same SPI bus with no data bus contention. This functionality enables three-phase power metering systems, containing three MCP3911 chips, controlled by a single SPI bus (single  $\overline{CS}$ , SCK, SDI and SDO pins).



**FIGURE 6-1:** Control Byte.

The default device address bits are '00'. Contact the Microchip factory for additional device address bits. For more information, please see the [Product Identification System](#) section.

A read on undefined addresses will give an all zeros output on the first, and all subsequent transmitted bytes. A write on an undefined address will have no effect, and also will not increment the address counter.

The register map is defined in [Table 7-1](#).

### 6.3 Reading from the Device

The first data byte read is the one defined by the address given in the CONTROL byte. After this first byte is transmitted, if the  $\overline{CS}$  pin is maintained low, the communication continues and the address of the next transmitted byte is determined by the status of the READ bits in the STATUSCOM register. Multiple looping configurations can be defined through the READ<1:0> bits for the address increment (see [Section 6.6 “SPI MODE 0,0 – Clock Idle Low, Read/Write Examples”](#)).

### 6.4 Writing to the Device

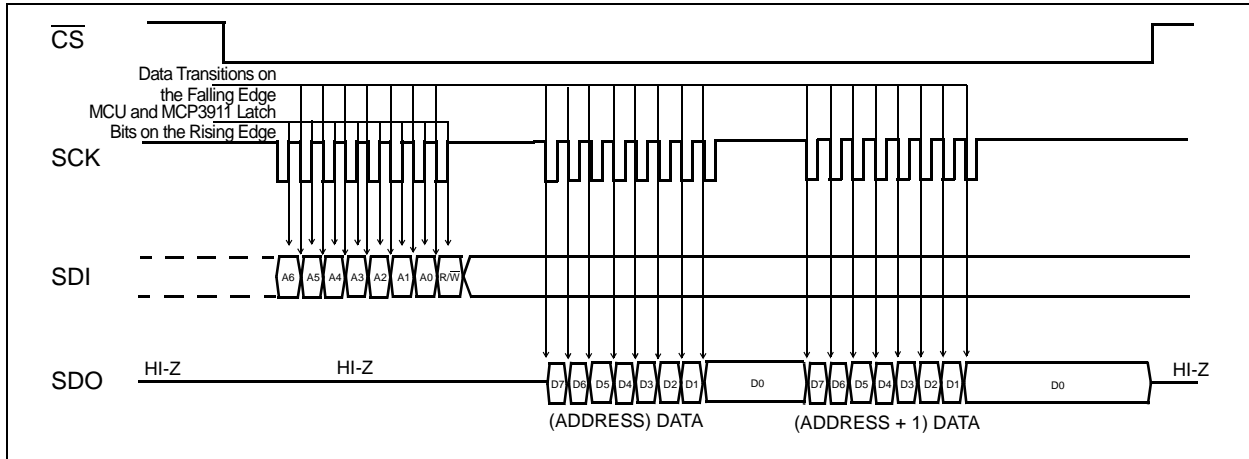
The first data byte written is the one defined by the address given in the control byte. Two write mode configurations for the address increment can be defined through the WRITE bit in the STATUSCOM register. When WRITE = 1, the write communication automatically increments the address for subsequent bytes. The address of the next transmitted byte within the same communication ( $\overline{CS}$  stays logic low) is the next address defined on the register map. At the end of the register map, the address loops to the beginning of the writable part of the register map (address 0x06). Writing a non-writable register has no effect. When WRITE = 0, the address is not incremented on the subsequent writes. The SDO pin stays in high-impedance during a write communication.

# MCP3911

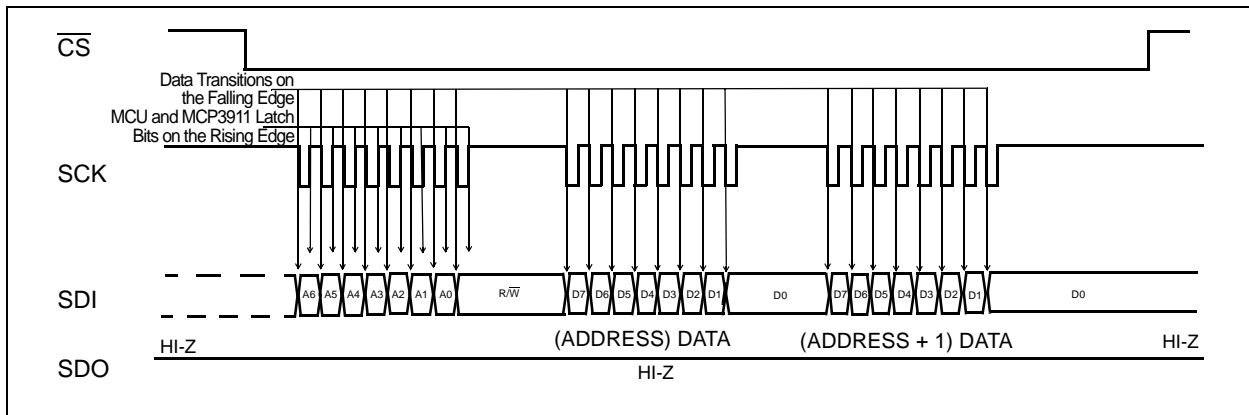
## 6.5 SPI MODE 1,1 – Clock Idle High, Read/Write Examples

In this SPI mode, SCK idles high. For the MCP3911, this means that there will be a falling edge on SCK before there is a rising edge.

**Note:** Changing from an SPI Mode 1,1 to an SPI Mode 0,0 is possible and can be done while  $\overline{CS}$  pin is logic high.



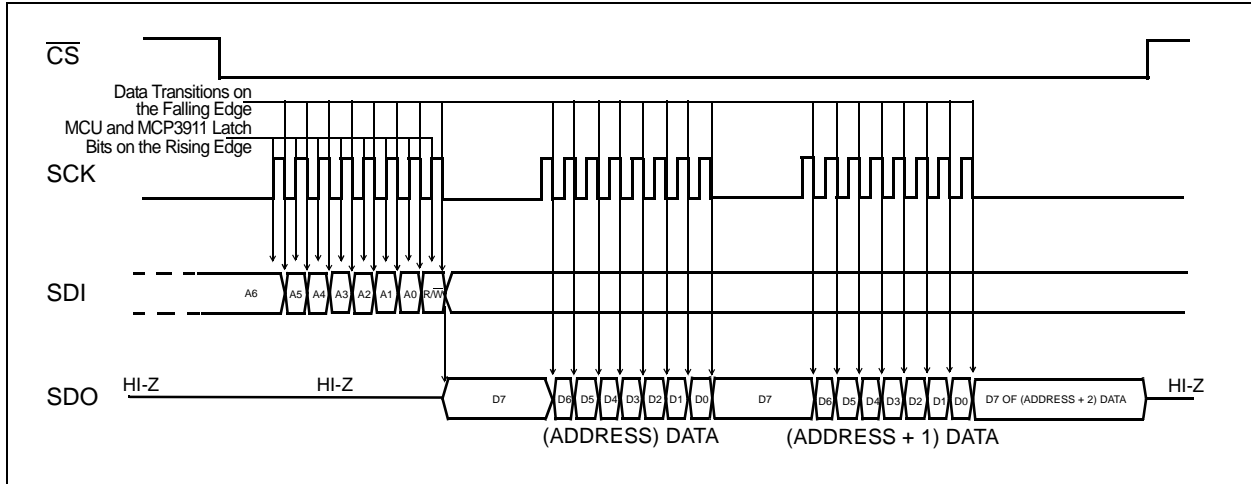
**FIGURE 6-2:** Device Read (SPI Mode 1,1 – SCK Idles High).



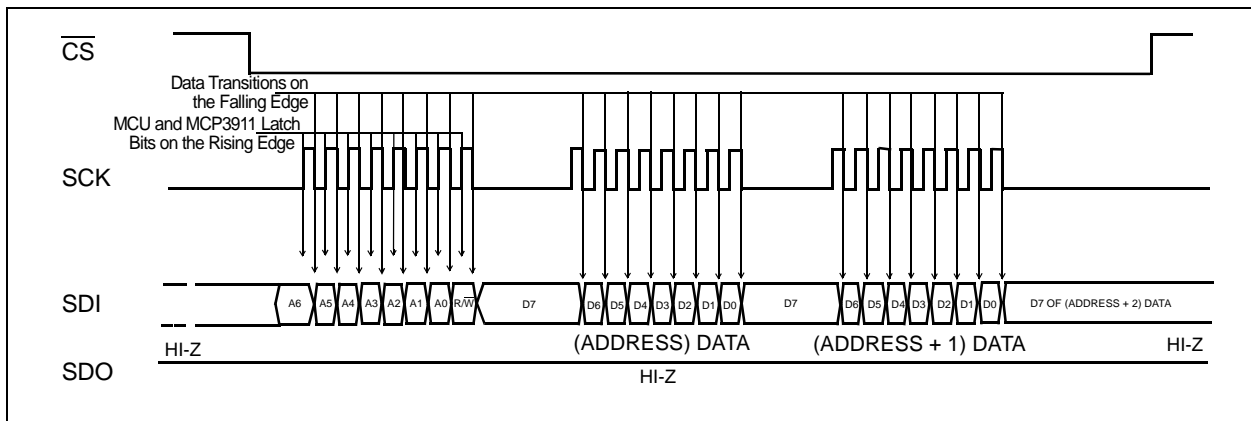
**FIGURE 6-3:** Device Write (SPI Mode 1,1 – SCK Idles High).

## 6.6 SPI MODE 0,0 – Clock Idle Low, Read/Write Examples

In this SPI mode, SCK idles low. For the MCP3911, this means that there will be a rising edge on SCK before there is a falling edge.



**FIGURE 6-4:** Device Read (SPI Mode 0,0 – SCK Idles Low).



**FIGURE 6-5:** Device Write (SPI Mode 0,0 – SCK Idles Low).

## 6.7 Continuous Communication, Looping on Address Sets

If the user wishes to read back either of the ADC channels continuously, or both channels continuously, the internal address counter of the MCP3911 can be set to loop on specific register sets. In this case, there is only one control byte on SDI to start the communication. The part stays within the same loop until  $\overline{CS}$  pin returns logic high.

This internal address counter allows the following functionality:

- Read one ADC channel data continuously
- Read both ADC channels data continuously (both ADC data can be independent or linked with DRMODE settings)
- Continuously read/write the entire register map
- Continuously read/write each separate register
- Continuously read all Configuration registers
- Write all Configuration registers in one communication (see [Figure 6-8](#))

### 6.7.1 CONTINUOUS READ

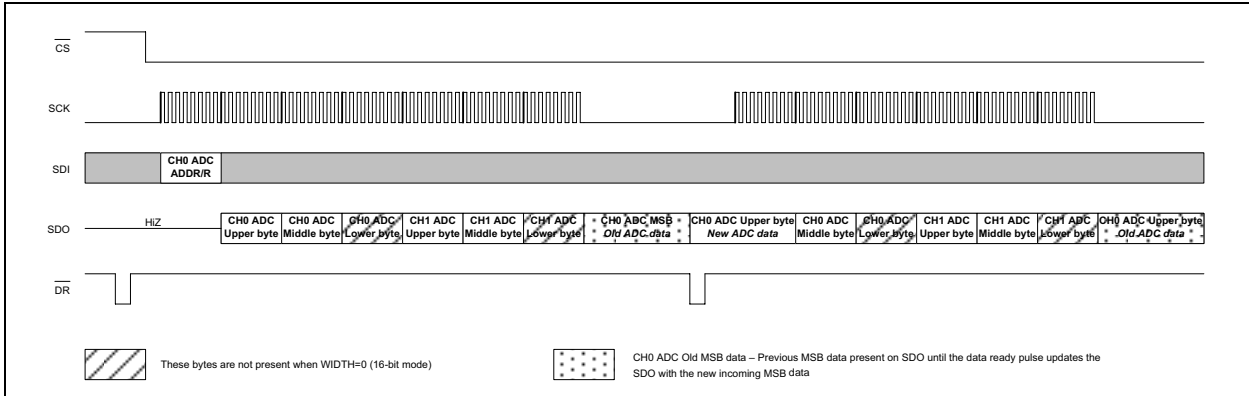
The STATUSCOM register contains the loop settings for the internal address counter (READ<1:0> bits and WRITE bit). The internal address counter can either stay constant (READ<1:0> = 00) and continuously read the same byte, or it can auto-increment and loop through the register groups defined below (READ<1:0> = 01), register types (READ<1:0> = 10) or the entire register map (READ<1:0> = 11).

Each ADC channel is configured independently as either a 16-bit or 24-bit data word, depending on the setting of the corresponding WIDTH bit in the STATUSCOM register.

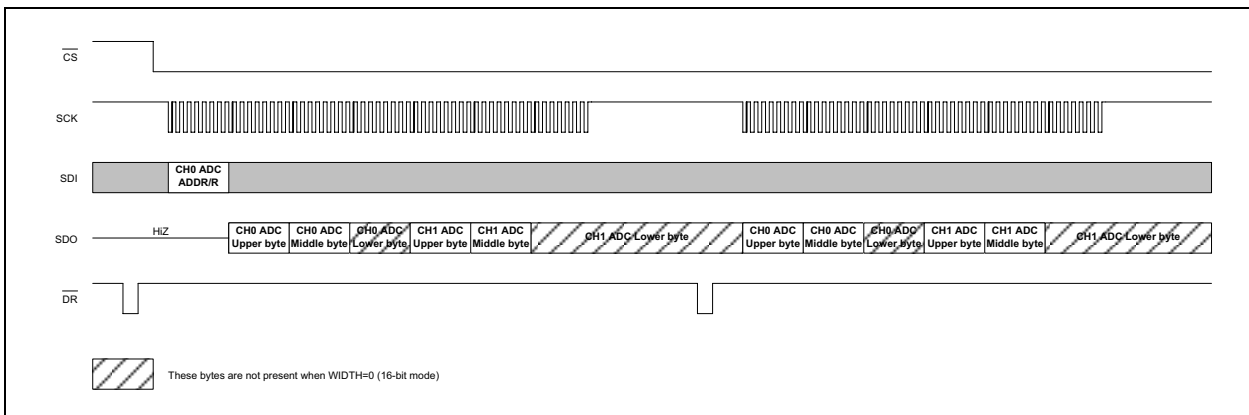
For continuous reading, in the case of WIDTH = 0 (16-bit), the lower byte of the ADC data is not accessed and the part jumps automatically to the following address (the user does not have to clock out the lower byte since it becomes undefined for WIDTH = 0).

[Figure 6-6](#) and [Figure 6-7](#) represent a typical, continuous read communication with the default settings (DRMODE<1:0> = 00, READ<1:0> = 10) for both WIDTH settings in case of the SPI Mode 0,0 ([Figure 6-6](#)) and SPI Mode 1,1 ([Figure 6-7](#)). This configuration is typically used for power metering applications.

**Note:** For continuous reading of ADC data in SPI Mode 0,0 (see [Figure 6-6](#)), once the data has been completely read after a data ready, the SDO pin will take the MSB value of the previous data at the end of the reading (falling edge of the last SCK clock). If SCK stays idle at logic low (by definition of Mode 0,0), the SDO pin will be updated at the falling edge of the next data ready pulse (synchronously with the DR pin falling edge with an output timing of  $t_{DODR}$ ) with the new MSB of the data corresponding to the data ready pulse. This mechanism allows the MCP3911 to continuously use read mode seamlessly in SPI Mode 0,0. In SPI Mode 1,1, the SDO stays in the last state (LSB of previous data) after a complete reading which also allows seamless continuous read mode. (see [Figure 6-7](#)).



**FIGURE 6-6:** Typical Continuous Read Communication (SPI Mode 0,0).



**FIGURE 6-7:** Typical Continuous Read Communication (SPI Mode 1,1).

# MCP3911

## 6.7.2 CONTINUOUS WRITE

Both ADCs are powered up with their default configurations, and begin to output data ready pulses immediately (RESET<1:0> and SHUTDOWN<1:0> bits are off by default).

The default output codes for both ADCs are all zeros. The default modulator output for both ADCs is '0011' (corresponding to a theoretical zero voltage at the inputs). The default phase is zero between the two channels.

It is recommended to enter into ADC Reset mode for both ADCs, just after power-up, because the desired MCP3911 register configuration may not be the default one, and in this case, the ADC would output undesired data. Within the ADC Reset mode (RESET<1:0> = 11), the user can configure the whole part with a single communication. The write commands automatically increment the address so that the user can start writing the PHASE register and finish with the CONFIG register in only one communication (see Figure 6-8). The RESET<1:0> bits are in the last byte of the CONFIG register to allow exiting the Soft Reset mode, and have the whole part configured and ready to run in only one command.

## 6.7.3 REGISTER GROUPS AND TYPES

The following register sets are defined as groups:

**TABLE 6-1: REGISTER GROUPS**

Group	Addresses
ADC DATA CH0	0x00-0x02
ADC DATA CH1	0x03-0x05
MOD, PHASE, GAIN	0x06-0x09
CONFIG, STATUSCOM	0x0A-0x0D
OFFCAL_CH0, GAINCAL_CH0	0x0E-0x13
OFFCAL_CH1, GAINCAL_CH1	0x14-0x19
VREFCAL	0x1A

The following register sets are defined as types:

**TABLE 6-2: REGISTER TYPES**

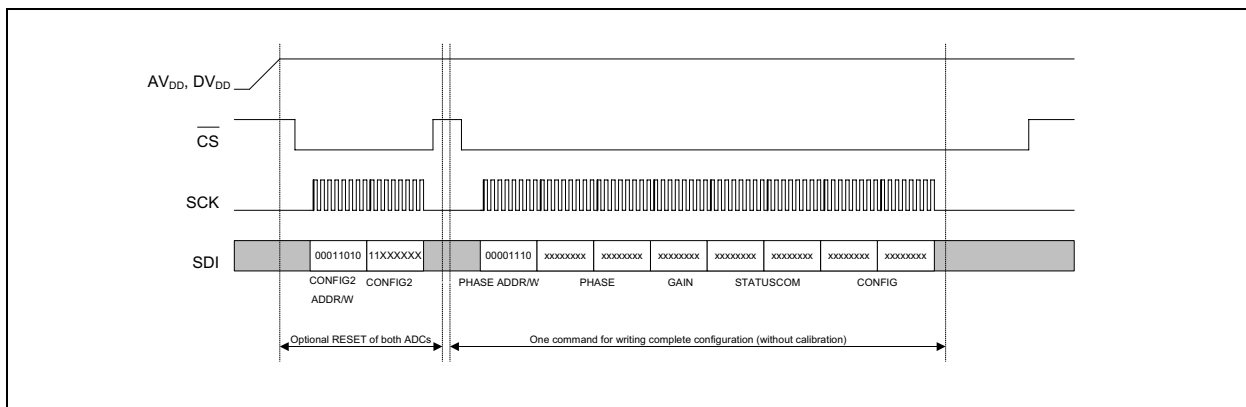
Type	Addresses
ADC DATA (both channels)	0x00-0x05
CONFIGURATION	0x06-0x1A

## 6.8 Situations that Reset ADC Data

Immediately after the following actions, the ADCs are reset and automatically restarted in order to provide proper operation:

1. Change in PHASE register
2. Change in the OSR setting
3. Change in the PRESCALE setting
4. Overwrite of the same PHASE register value
5. Change in the CLKEXT setting
6. Change in the VREFEXT setting
7. Change in the MODOUT setting

After these temporary resets, the ADCs go back to the normal operation, with no need for an additional command. The PHASE register can be used to serially Soft Reset the ADCs, without using the RESET bits in the Configuration register, if the same value is written in the PHASE register.



**FIGURE 6-8:** Recommended Configuration Sequence at Power-up.



## 6.9 Data Ready Pin ( $\overline{DR}$ )

To signify when channel data is ready for transmission, the data ready signal is available on the Data Ready pin ( $\overline{DR}$ ) through an active-low pulse at the end of a channel conversion.

The data ready pin outputs an active-low pulse with a period that is equal to the DRCLK clock period, and with a width equal to one DMCLK period.

When not active-low, this pin can either be in high-impedance (when  $\overline{DR\_HIZ} = 0$ ) or in a defined logic high state (when  $\overline{DR\_HIZ} = 1$ ). This is controlled through the STATUSCOM register. This allows multiple devices to share the same data ready pin (with a pull-up resistor connected between  $\overline{DR}$  and  $DV_{DD}$ ) in 3-phase, energy meter designs to reduce pin count. A single device on the bus does not require a pull-up resistor and therefore it is recommended to use  $\overline{DR\_HIZ} = 1$  configuration for such applications.

After a data ready pulse has occurred, the ADC output data can be read through SPI communication. Two sets of latches at the output of the ADC prevent the communication from outputting corrupted data (see [Section 6.10 “ADC Data Latches and Data Ready Modes \(DRMODE<1:0>\)”](#)).

The  $\overline{CS}$  pin has no effect on the  $\overline{DR}$  pin, which means even if  $\overline{CS}$  is logic high, data ready pulses will be provided (except when the configuration prevents them from outputting data ready pulses). The  $\overline{DR}$  pin can be used as an interrupt when connected to an MCU or DSP. While the RESET pin is logic low, the  $\overline{DR}$  pin is not active.

## 6.10 ADC Data Latches and Data Ready Modes (DRMODE<1:0>)

To ensure that both channels' ADC data is present at the same time for SPI read, regardless of phase delay settings for either or both channels, there are two sets of ADC data latches in series with both the data ready and the 'read start' triggers.

The first set of latches holds each output when the data is ready and latches both outputs together when DRMODE<1:0> = 00. When this mode is on, both ADCs work together and produce one set of available data after each data ready pulse (that corresponds to the lagging ADC data ready). The second set of latches ensures that when reading starts on an ADC output, the corresponding data is latched so that no data corruption can occur.

If an ADC read has started, in order to read the following ADC output, the current reading needs to be completed (all bits must be read from the ADC Output Data registers).

### 6.10.1 DATA READY PIN ( $\overline{DR}$ ) CONTROL USING DRMODE BITS

There are four modes that control the data ready pulses and these modes are set with the DRMODE<1:0> bits in the STATUSCOM register. For power metering applications, DRMODE<1:0> = 00 is recommended (Default mode).

The position of the data ready pulses vary, with respect to this mode, to the OSR and to the PHASE settings:

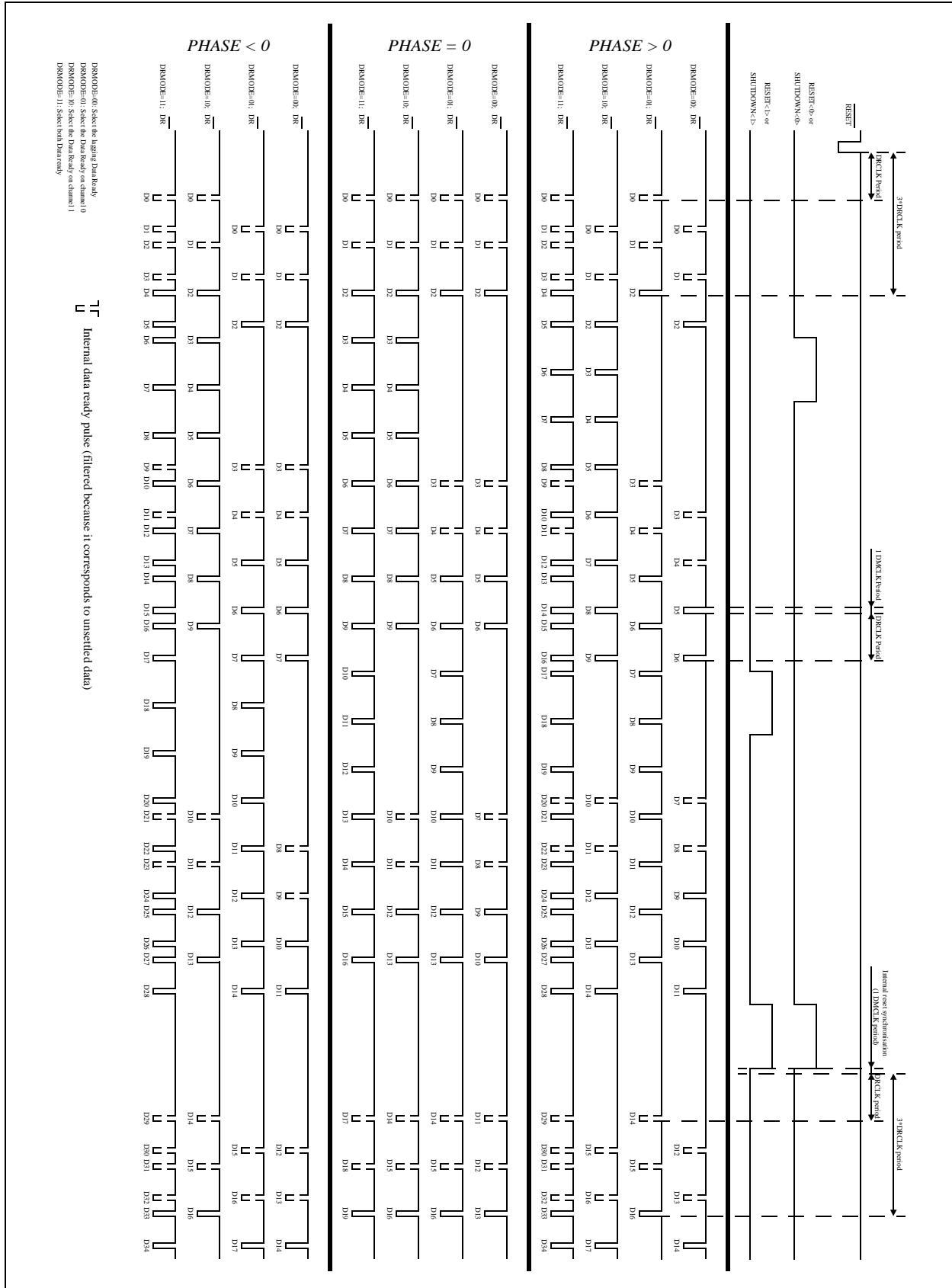
- **DRMODE<1:0> = 11:** Both data ready pulses from ADC Channel 0 and ADC Channel 1 are output on the  $\overline{DR}$  pin.
- **DRMODE<1:0> = 10:** Data ready pulses from ADC Channel 1 are output on the  $\overline{DR}$  pin. The data ready pulse from ADC Channel 0 is not present on the pin.
- **DRMODE<1:0> = 01:** Data ready pulses from ADC Channel 0 are output on the  $\overline{DR}$  pin. The data ready pulse from ADC Channel 1 is not present on the pin.
- **DRMODE<1:0> = 00 (Recommended and Default mode):** Data ready pulses from the lagging ADC between the two are output on the  $\overline{DR}$  pin. The lagging ADC depends on the PHASE register and on the OSR. In this mode, the two ADCs are linked together so their data is latched together when the lagging ADC output is ready.

### 6.10.2 DATA READY PULSES WITH SHUTDOWN OR RESET CONDITIONS

There will be no data ready pulses if DRMODE<1:0> = 00 when either one or both of the ADCs are in Reset or shutdown. In Mode 0,0, a data ready pulse only happens when both ADCs are ready. Any data ready pulse will correspond to one data on both ADCs. The two ADCs are linked together and act as if there was only one channel with the combined data of both ADCs. This mode is very practical when both ADC channels' data retrieval and processing need to be synchronized, as in power metering applications.

<p><b>Note:</b> If DRMODE&lt;1:0&gt; = 11, the user will still be able to retrieve the data ready pulse for the ADC not in shutdown or Reset (i.e., only 1 ADC channel needs to be awake).</p>
--

[Figure 6-9](#) represents the behavior of the data ready pin with the different DRMODE configurations, while shutdown or reset are applied.



**FIGURE 6-9:** Data Ready Behavior.

## 7.0 INTERNAL REGISTERS

The addresses associated with the internal registers are listed below. A detailed description of the registers follows. All registers are split in 8-bit long registers, which can be addressed and read separately. Read and Write modes define the groups and types of registers for continuous read/write communication or looping on address sets as shown in [Register 7-2](#).

**TABLE 7-1: REGISTER MAP**

Address	Name	Bits	R/W	Description
0x00	CHANNEL0	24	R	Channel 0 ADC 24-bit Data <23:0>, MSB first
0x03	CHANNEL1	24	R	Channel 1 ADC 24-bit Data <23:0>, MSB first
0x06	MOD	8	R/W	Modulator Output Register for both ADC channels
0x07	PHASE	16	R/W	Phase Delay Configuration Register
0x09	GAIN	8	R/W	Gain and Boost Configuration Register
0x0A	STATUSCOM	16	R/W	Status and Communication Register
0x0C	CONFIG	16	R/W	Configuration Register
0x0E	OFFCAL_CH0	24	R/W	Offset Correction Register - Channel 0
0x11	GAINCAL_CH0	24	R/W	Gain Correction Register - Channel 0
0x14	OFFCAL_CH1	24	R/W	Offset Correction Register - Channel 1
0x17	GAINCAL_CH1	24	R/W	Gain Correction Register - Channel 1
0x1A	VREFCAL	8	R/W	Internal Voltage reference Temperature Coefficient Adjustment Register

# MCP3911

**TABLE 7-2: REGISTER MAP GROUPING FOR ALL CONTINUOUS READ/WRITE MODES**

Function	Address	READ<1:0>				WRITE	
		= "11"	= "10"	= "01"	= "00"	= "1"	= "0"
CHANNEL 0	0x00	LOOP ENTIRE REGISTER MAP	TYPE	GROUP	Static	LOOP ENTIRE REGISTER MAP	Static
	0x01				Static		Static
	0x02				Static		Static
CHANNEL 1	0x03			GROUP	Static		Static
	0x04				Static		Static
	0x05				Static		Static
MOD	0x06		GROUP	Static	Static		
PHASE	0x07			Static	Static		
	0x08			Static	Static		
GAIN	0x09		GROUP	Static	Static		
STATUSCOM	0x0A			Static	Static		
	0x0B		Static	Static			
CONFIG			0x0C	GROUP	Static		Static
	0x0D		Static		Static		
OFFCAL_CH0	0x0E		TYPE	GROUP	Static		Static
	0x0F				Static		Static
	0x10				Static		Static
GAINCAL_CH0	0x11			GROUP	Static		Static
	0x12	Static			Static		
	0x13	Static			Static		
OFFCAL_CH1	0x14	TYPE	GROUP	Static	Static		
	0x15			Static	Static		
	0x16			Static	Static		
GAINCAL_CH1	0x17		GROUP	Static	Static		
	0x18			Static	Static		
	0x19			Static	Static		
VREFCAL	0x1A	GROUP	Static	Static			

## 7.1 CHANNEL REGISTERS - ADC CHANNEL DATA OUTPUT REGISTERS

The ADC Channel Data Output registers always contain the most recent A/D conversion data for each channel. These registers are read-only. They can be accessed independently or linked together (with READ<1:0> bits). These registers are latched when an ADC read communication occurs. When a data ready event occurs during a read communication, the most current ADC data is also latched to avoid data corruption issues. The three bytes of each channel are updated synchronously at a DRCLK rate. The three bytes can be accessed separately if needed, but are refreshed synchronously.

### REGISTER 7-1: CHANNEL REGISTER

Name	Bits	Address	R/W
CHANNEL0	24	0x00	R
CHANNEL1	24	0x03	R

R-0	R-0	R-0	R-0	R-0	R-0	R-0	R-0
DATA_CHn <23> (MSB)	DATA_CHn <22>	DATA_CHn <21>	DATA_CHn <20>	DATA_CHn <19>	DATA_CHn <18>	DATA_CHn <17>	DATA_CHn <16>
bit 23							bit 16

R-0	R-0	R-0	R-0	R-0	R-0	R-0	R-0
DATA_CHn <15>	DATA_CHn <14>	DATA_CHn <13>	DATA_CHn <12>	DATA_CHn <11>	DATA_CHn <10>	DATA_CHn <9>	DATA_CHn <8>
bit 15							bit 8

R-0	R-0	R-0	R-0	R-0	R-0	R-0	R-0
DATA_CHn <7>	DATA_CHn <6>	DATA_CHn <5>	DATA_CHn <4>	DATA_CHn <3>	DATA_CHn <2>	DATA_CHn <1>	DATA_CHn <0>
bit 7							bit 0

#### Legend:

R = Readable bit                      W = Writable bit                      U = Unimplemented bit, read as '0'  
 -n = Value at POR                      '1' = Bit is set                      '0' = Bit is cleared                      x = Bit is unknown

bit 23:0                      **DATA\_CHn:** Output code from ADC Channel n. This data is post-calibration if the EN\_OFFCAL or EN\_GAINCAL bits are enabled.

# MCP3911

## 7.2 MOD REGISTER - MODULATORS OUTPUT REGISTER

### REGISTER 7-2: MOD Register

Name	Bits	Address	Cof
MOD	8	0x06	R/W

The MOD register contains the most recent modulator data output. The default value corresponds to an equivalent input of 0V on both ADCs. Each bit in this register corresponds to one comparator output on one of the channels.

Comparator3 Channel 1	Comparator2 Channel 1	Comparator1 Channel 1	Comparator0 Channel 1	Comparator3 Channel 0	Comparator2 Channel 0	Comparator1 Channel 0	Comparator0 Channel 0
R/W-0	R/W-0	R/W-1	R/W-1	R/W-0	R/W-0	R/W-1	R/W-1
COMP3_CH1	COMP2_CH1	COMP1_CH1	COMP0_CH1	COMP3_CH0	COMP2_CH0	COMP1_CH0	COMP0_CH0
bit 7	bit 6	bit 5	bit 4	bit 3	bit 2	bit 1	bit 0

#### Legend:

R = Readable bit

W = Writable bit

U = Unimplemented bit, read as '0'

-n = Value at POR

'1' = Bit is set

'0' = Bit is cleared

x = Bit is unknown

bit 7:4      **COMPn\_CH1**: Comparator Outputs from ADC Channel 1

bit 3:0      **COMPn\_CH0**: Comparator Outputs from ADC Channel 0

## 7.3 PHASE Register - Phase Configuration Register

### REGISTER 7-3: PHASE Register

Name	Bits	Address	Cof
PHASE	16	0x07	R/W

Any write to one of these two addresses (0x07 and 0x08) creates an internal reset and restart sequence.

U-0	U-0	U-0	U-0	R/W-0	R/W-0	R/W-0	R/W-0
—	—	—	—	PHASE<11>	PHASE<10>	PHASE<9>	PHASE<8>
				bit 11			bit 8
R/W-0	R/W-0	R/W-0	R/W-0	R/W-0	R/W-0	R/W-0	R/W-0
PHASE<7>	PHASE<6>	PHASE<5>	PHASE<4>	PHASE<3>	PHASE<2>	PHASE<1>	PHASE<0>
bit 7							bit 0

#### Legend:

R = Readable bit	W = Writable bit	U = Unimplemented bit, read as '0'
-n = Value at POR	'1' = Bit is set	'0' = Bit is cleared
		x = Bit is unknown

bit 15:12 Unimplemented, read as '0'

bit 11:0 CH0 relative to CH1 phase delay

PHASE<11:0>: CH0 Relative to CH1 Phase Delay bits

Delay = PHASE Register's two's complement code/DMCLK (Default PHASE = 0).

# MCP3911

## 7.4 Gain - GAIN AND BOOST CONFIGURATION REGISTER

### REGISTER 7-4: GAIN Register

Name	Bits	Address	Cof
GAIN	8	0x09	R/W

R/W-1	R/W-0	R/W-0	R/W-0	R/W-0	R/W-0	R/W-0	R/W-0
BOOST<1>	BOOST<0>	PGA_CH1<2>	PGA_CH1<1>	PGA_CH1<0>	PGA_CH0<2>	PGA_CH0<1>	PGA_CH0<0>
bit 7							bit 0

#### Legend:

R = Readable bit      W = Writable bit      U = Unimplemented bit, read as '0'  
-n = Value at POR      '1' = Bit is set      '0' = Bit is cleared      x = Bit is unknown

- bit 7:6    **BOOST<1:0>** Bias Current Selection  
11 = Both channels have current x 2  
10 = Both channels have current x 1(DEFAULT)  
01 = Both channels have current x 0.66  
00 = Both channels have current x 0.5
- bit 5:3    **PGA\_CH1<2:0>**: PGA Setting for Channel 1  
111 = Reserved (Gain = 1)  
110 = Reserved (Gain = 1)  
101 = Gain is 32  
100 = Gain is 16  
011 = Gain is 8  
010 = Gain is 4  
001 = Gain is 2  
000 = Gain is 1 (DEFAULT)
- bit 2:0    **PGA\_CH0<2:0>**: PGA Setting for Channel 0  
111 = Reserved (Gain = 1)  
110 = Reserved (Gain = 1)  
101 = Gain is 32  
100 = Gain is 16  
011 = Gain is 8  
010 = Gain is 4  
001 = Gain is 2  
000 = Gain is 1 (DEFAULT)



## 7.5 STATUSCOM Register - Status And Communication Register

**REGISTER 7-5: STATUSCOM Register**

Name	Bits	Address	Cof
STATUSCOM	16	0x0A	R/W

R/W-0	R/W-0	U-0	R/W-0	R/W-0	R/W-0	R/W-1	R/W-1
MODOUT<1>	MODOUT<0>	—	$\overline{\text{DR\_HIZ}}$	DRMODE<1>	DRMODE<0>	DRSTATUS<1>	DRSTATUS<0>
bit 15							bit 8
R/W-1	R/W-0	R/W-1	R/W-1	R/W-1	R/W-0	R/W-0	U-0
READ<1>	READ<0>	WRITE	WIDTH<1>	WIDTH<0>	EN_OFFCAL	EN_GAINCAL	—
bit 7							bit 0

**Legend:**

R = Readable bit                      W = Writable bit                      U = Unimplemented bit, read as '0'  
 -n = Value at POR                      '1' = Bit is set                      '0' = Bit is cleared                      x = Bit is unknown

- bit 15:14      **MODOUT<1:0>: Modulator Output Setting for MDAT pins**  
 11 = Both CH0 and CH1 modulator outputs are present on MDAT1 and MDAT0 pins, both SINC filters are off, no data ready pulse is present  
 10 = CH1 ADC Modulator output present on MDAT1 pin, SINC filter on channel 1 is off, data ready pulse from channel 1 is not present on  $\overline{\text{DR}}$  pin  
 01 = CH0 ADC Modulator output present on MDAT0 pin, SINC filter on channel 0 is off, data ready pulse from channel 0 is not present on  $\overline{\text{DR}}$  pin  
 00 = No Modulator output is enabled, SINC filters are on, data readys are present on  $\overline{\text{DR}}$  pin for both channels (**DEFAULT**)
- bit 13      Unimplemented, read as 0
- bit 12      **DR\_HIZ: Data Ready Pin Inactive State Control**  
 1 = The  $\overline{\text{DR}}$  pin state is a logic high when data is NOT ready  
 0 = The  $\overline{\text{DR}}$  pin state is high impedance when data is NOT ready(**DEFAULT**)
- bit 11:10      **DRMODE<1:0>: Data Ready Pin ( $\overline{\text{DR}}$ ) mode configuration bits**  
 11 = Both Data Ready pulses from CH0 and CH1 are output on  $\overline{\text{DR}}$  pin  
 10 = Data Ready pulses from CH1 ADC are output on  $\overline{\text{DR}}$  pin. Data ready pulses from CH0 are not present on the  $\overline{\text{DR}}$  pin.  
 01 = Data Ready pulses from CH0 ADC are output on  $\overline{\text{DR}}$  pin. Data ready pulses from CH1 are not present on the DR pin.  
 00 = Data Ready pulses from the lagging ADC between the two are output on  $\overline{\text{DR}}$  pin. The lagging ADC depends on the PHASE register and on the OSR. (**DEFAULT**)
- bit 9:8      **DRSTATUS<1:0>: Data Ready Status**  
 11 = ADC Channel 1 and Channel 0 data not ready (**DEFAULT**)  
 10 = ADC Channel 1 data not ready, ADC Channel 0 data ready  
 01 = ADC Channel 0 data not ready, ADC Channel 1 data ready  
 00 = ADC Channel 1 and Channel 0 data ready
- bit 7:6      **READ<1:0>: Address Loop Setting**  
 11 = Address counter incremented, cycle through entire register set  
 10 = Address counter loops on register types (**DEFAULT**)  
 01 = Address counter loops on register groups  
 00 = Address not incremented, continually read single register
- bit 5      **WRITE: Address Loop Setting for Write mode**  
 1 = Address counter loops on entire register map (**DEFAULT**)  
 0 = Address not incremented, continually write same single register

# MCP3911

---

- bit 4:3      **WIDTH<1:0>** ADC Channel output data word width  
11 = Both channels are in 24-bit mode(**DEFAULT**)  
10 = Channel1 in 24-bit mode, Channel0 in 16-bit mode  
01 = Channel1 in 16-bit mode, Channel0 in 24-bit mode  
00 = Both channels are in 16-bit mode
- bit 2      **EN\_OFFCAL** Enables or disables the 24-bit digital offset calibration on both channels  
1 = Enabled; this mode does not add any group delay  
0 = Disabled (**DEFAULT**)
- bit 1      **EN\_GAINCAL** Enables or disables the 24-bit digital offset calibration on both channels  
1 = Enabled; this mode adds a group delay on both channels of 24 DMCLK periods. All data ready pulses are delayed by 24 clock periods compared to the mode with EN\_GAINCAL=0  
0 = Disabled(**DEFAULT**)
- bit 0      Unimplemented, read as 0

## 7.6 CONFIG Register - Configuration Register

### REGISTER 7-6: CONFIG Register

Name	Bits	Address	Cof
CONFIG	16	0x0C	R/W

R/W-0	R/W-0	R/W-0	R/W-1	R/W-1	R/W-1	R/W-1	R/W-0
PRE<1>	PRE<0>	OSR<2>	OSR<1>	OSR<0>	DITHER<1>	DITHER<0>	AZ_FREQ
bit 15							bit 8
R/W-0	R/W-0	R/W-0	R/W-0	U-0	R/W-0	R/W-1	U-0
RESET<1>	RESET<0>	SHUT-DOWN<1>	SHUT-DOWN<0>	—	VREFEXT	CLKEXT	—
bit 7							bit 0

#### Legend:

R = Readable bit	W = Writable bit	U = Unimplemented bit, read as '0'
-n = Value at POR	'1' = Bit is set	'0' = Bit is cleared
		x = Bit is unknown

- bit 15:14 **PRE<1:0>** Analog Master Clock (AMCLK) Prescaler Value  
 11 = AMCLK = MCLK / 8  
 10 = AMCLK = MCLK / 4  
 01 = AMCLK = MCLK / 2  
 00 = AMCLK = MCLK (DEFAULT)
- bit 13:11 **OSR<2:0>** Oversampling Ratio for Delta-Sigma A/D Conversion (ALL CHANNELS,  $f_d / f_s$ )  
 111 = 4096 ( $f_d = 244$  sps for MCLK = 4 MHz,  $f_s =$  AMCLK = 1 MHz)  
 110 = 2048 ( $f_d = 488$  sps for MCLK = 4 MHz,  $f_s =$  AMCLK = 1 MHz)  
 101 = 1024 ( $f_d = 976$  sps for MCLK = 4 MHz,  $f_s =$  AMCLK = 1 MHz)  
 100 = 512 ( $f_d = 1.953$  ksp for MCLK = 4 MHz,  $f_s =$  AMCLK = 1 MHz)  
 011 = 256 ( $f_d = 3.90625$  ksp for MCLK = 4 MHz,  $f_s =$  AMCLK = 1 MHz) (DEFAULT)  
 010 = 128 ( $f_d = 7.8125$  ksp for MCLK = 4 MHz,  $f_s =$  AMCLK = 1 MHz)  
 001 = 64 ( $f_d = 15.625$  ksp for MCLK = 4 MHz,  $f_s =$  AMCLK = 1 MHz)  
 000 = 32 ( $f_d = 31.25$  ksp for MCLK = 4 MHz,  $f_s =$  AMCLK = 1 MHz)
- bit 10:9 **DITHER<1:0>** Control for dithering circuit for idle tones cancellation and improved THD  
 11 = Dithering ON, both channels, Strength = Maximum(MCP3901 Equivalent) - (DEFAULT)  
 10 = Dithering ON, both channels, Strength = Medium  
 01 = Dithering ON, both channels, Strength = Minimum  
 00 = Dithering turned OFF
- bit 8 **AZ\_FREQ** Auto-zero frequency setting  
 1 = Auto-zeroing algorithm running at higher speed  
 0 = Auto-zeroing algorithm running at lower speed (Default)
- bit 7:6 **RESET<1:0>**: Reset mode setting for ADCs  
 11 = Both CH0 and CH1 ADC are in reset mode  
 10 = CH1 ADC in reset mode  
 01 = CH0 ADC in reset mode  
 00 = Neither ADC in reset mode(default)
- bit 5:4 **SHUTDOWN<1:0>**: Shutdown mode setting for ADCs  
 11 = Both CH0 and CH1 ADC in Shutdown  
 10 = CH1 ADC in Shutdown  
 01 = CH0 ADC in Shutdown  
 00 = Neither Channel in Shutdown(default)
- bit 3 Not implemented, read as 0

# MCP3911

- bit 2      **VREFEXT** Internal Voltage Reference Shutdown Control  
           1 = Internal Voltage Reference Disabled  
           0 = Internal Voltage Reference Enabled (Default)
- bit 1      **CLKEXT** Internal Clock selection bits  
           1 = External clock drive by MCU on OSC1 pin (crystal oscillator disabled, no internal power consumption) (Default)  
           0 = Crystal oscillator is enabled. A crystal must be placed between OSC1 and OSC2 pins.
- bit 0      Not implemented, read as 0

## 7.7 OFFCAL\_CHn REGISTERS - DIGITAL OFFSET ERROR CALIBRATION REGISTERS

### REGISTER 7-7: OFFCAL\_CHn REGISTERS

Name	Bits	Address	Cof
OFFCAL_CH0	24	0x0E	R/W
OFFCAL_CH1	24	0x14	R/W

R/W-0	R/W-0	R/W-0	...	R/W-0	R/W-0	R/W-0	R/W-0
OFFCAL_CHn <23>	OFFCAL_CHn <22>	OFFCAL_CHn <21>	...	OFFCAL_CHn <3>	OFFCAL_CHn <2>	OFFCAL_CHn <1>	OFFCAL_CHn <0>
bit 23							bit 0

#### Legend:

R = Readable bit	W = Writable bit	U = Unimplemented bit, read as '0'
-n = Value at POR	'1' = Bit is set	'0' = Bit is cleared      x = Bit is unknown

bit 23:0      Digital Offset calibration value for the corresponding channel CHn. This register simply is added to the output code of the channel bit-by-bit. This register is 24-bit two's complement MSB first coding. CHn Output Code = OFFCAL\_CHn + ADC CHn Output Code. This register is a Don't Care if EN\_OFFCAL=0 (Offset calibration disabled) but its value is not cleared by the EN\_OFFCAL bit.

## 7.8 GAINCAL\_CHn REGISTERS - DIGITAL GAIN ERROR CALIBRATION REGISTERS

### REGISTER 7-8: GAINCAL\_CHn REGISTERS

Name	Bits	Address	Cof
GAINCAL_CH0	24	0x11	R/W
GAINCAL_CH1	24	0x17	R/W

R/W-0	R/W-0	R/W-0	...	R/W-0	R/W-0	R/W-0	R/W-0
GAINCAL_CHn <23>	GAINCAL_CHn <22>	GAINCAL_CHn <21>	...	GAINCAL_CHn <3>	GAINCAL_CHn <2>	GAINCAL_CHn <1>	GAINCAL_CHn <0>
bit 23							bit 0

#### Legend:

R = Readable bit	W = Writable bit	U = Unimplemented bit, read as '0'
-n = Value at POR	'1' = Bit is set	'0' = Bit is cleared      x = Bit is unknown

bit 23:0      Digital gain error calibration value for the corresponding channel CHn. This register is 24-bit signed MSB first coding with a range of -1x to +0.9999999x (from 0x80000 to 0x7FFFFFFF). The gain calibration adds 1x to this register and multiplies it to the output code of the channel bit by bit, after offset calibration. The range of the gain calibration is thus from 0x to 1.9999999x (from 0x80000 to 0x7FFFFFFF). The LSB corresponds to a  $2^{-23}$  increment in the multiplier.

CHn Output Code = (GAINCAL\_CHn+1)\*ADC CHn Output Code. This register is a Don't Care if EN\_GAINCAL=0 (Offset calibration disabled) but its value is not cleared by the EN\_GAINCAL bit.

# MCP3911

## 7.9 VREFCAL Register – Internal Voltage Reference Temperature Coefficient Adjustment Register

### REGISTER 7-9: VREFCAL REGISTER

Name	Bits	Address	Cof
VREFCAL	8	0x1A	R/W

This register is only for advanced users. This register should not be written unless the user wants to calibrate the temperature coefficient of the whole system or application. The default value of this register is set to 0x42.

R/W-0	R/W-1	R/W-0	R/W-0	R/W-0	R/W-0	R/W-1	R/W-0
VREFCAL<7>	VREFCAL<6>	VREFCAL<5>	VREFCAL<4>	VREFCAL<3>	VREFCAL<2>	VREFCAL<1>	VREFCAL<0>
bit 7							bit 0

#### Legend:

R = Readable bit

W = Writable bit

U = Unimplemented bit, read as '0'

-n = Value at POR

'1' = Bit is set

'0' = Bit is cleared

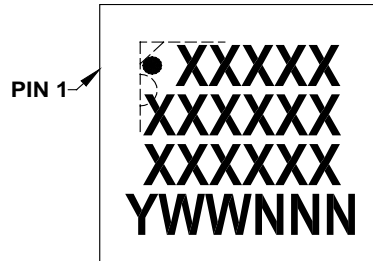
x = Bit is unknown

bit 7:0 Internal Voltage Temperature coefficient register value. (See [Section 5.7.3 “Temperature compensation \(VREFCAL register\)”](#) for complete description).

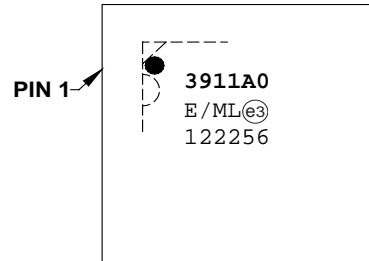
## 8.0 PACKAGING INFORMATION

### 8.1 Package Marking Information

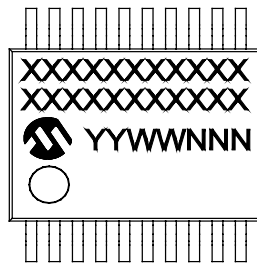
20-Lead QFN (4x4x0.9 mm)



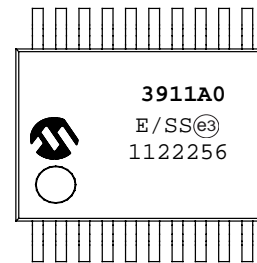
Example:



20-Lead SSOP (SS)



Example:



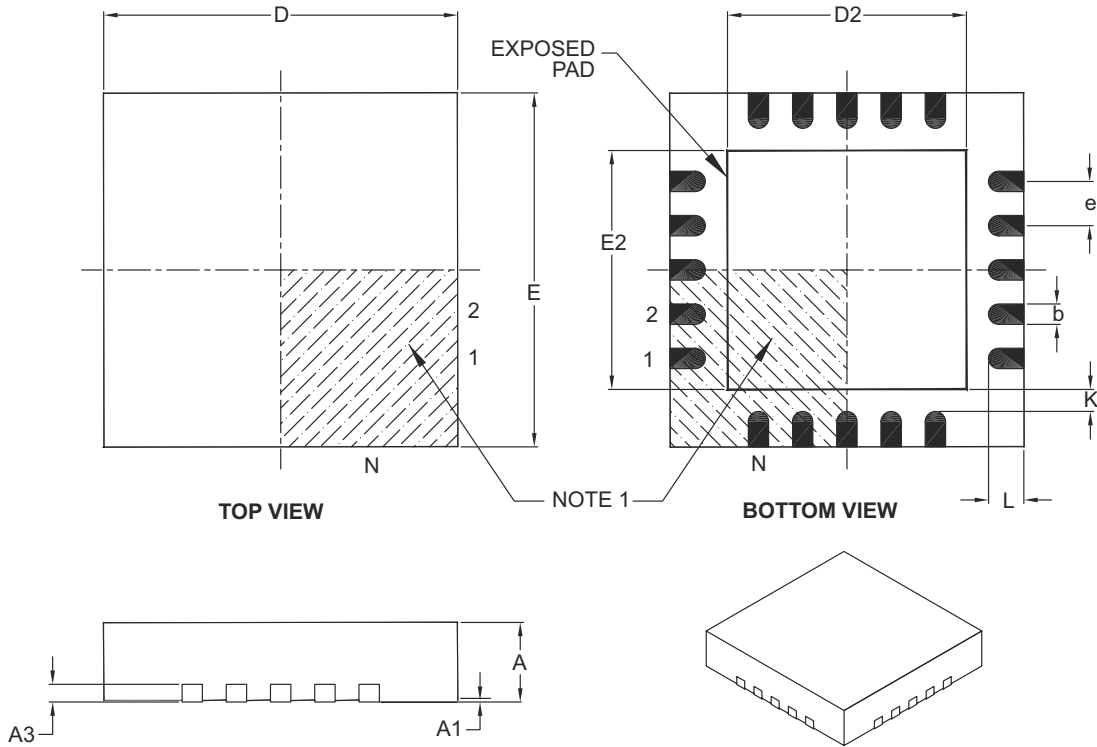
<b>Legend:</b>	XX...X	Customer-specific information
	Y	Year code (last digit of calendar year)
	YY	Year code (last 2 digits of calendar year)
	WW	Week code (week of January 1 is week '01')
	NNN	Alphanumeric traceability code
	(e3)	Pb-free JEDEC designator for Matte Tin (Sn)
	*	This package is Pb-free. The Pb-free JEDEC designator (e3) can be found on the outer packaging for this package.

**Note:** In the event the full Microchip part number cannot be marked on one line, it will be carried over to the next line, thus limiting the number of available characters for customer-specific information.

# MCP3911

## 20-Lead Plastic Quad Flat, No Lead Package (ML) – 4x4x0.9 mm Body [QFN]

**Note:** For the most current package drawings, please see the Microchip Packaging Specification located at <http://www.microchip.com/packaging>



Dimension Limits	Units	MILLIMETERS		
		MIN	NOM	MAX
Number of Pins	N	20		
Pitch	e	0.50 BSC		
Overall Height	A	0.80	0.90	1.00
Standoff	A1	0.00	0.02	0.05
Contact Thickness	A3	0.20 REF		
Overall Width	E	4.00 BSC		
Exposed Pad Width	E2	2.60	2.70	2.80
Overall Length	D	4.00 BSC		
Exposed Pad Length	D2	2.60	2.70	2.80
Contact Width	b	0.18	0.25	0.30
Contact Length	L	0.30	0.40	0.50
Contact-to-Exposed Pad	K	0.20	–	–

**Notes:**

- Pin 1 visual index feature may vary, but must be located within the hatched area.
- Package is saw singulated.
- Dimensioning and tolerancing per ASME Y14.5M.

BSC: Basic Dimension. Theoretically exact value shown without tolerances.

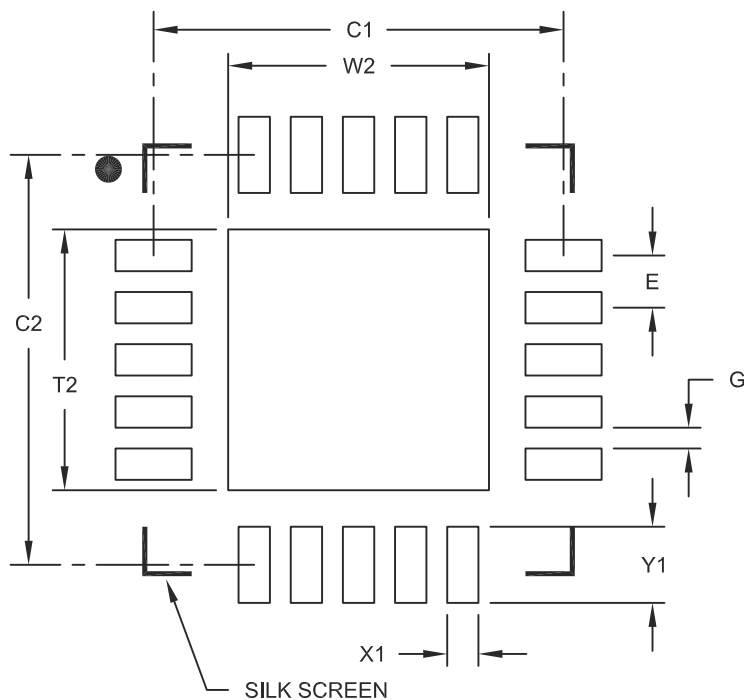
REF: Reference Dimension, usually without tolerance, for information purposes only.

Microchip Technology Drawing C04-126B



20-Lead Plastic Quad Flat, No Lead Package (ML) - 4x4 mm Body [QFN]  
With 0.40 mm Contact Length

**Note:** For the most current package drawings, please see the Microchip Packaging Specification located at <http://www.microchip.com/packaging>



RECOMMENDED LAND PATTERN

Dimension Limits	Units	MILLIMETERS		
		MIN	NOM	MAX
Contact Pitch	E	0.50 BSC		
Optional Center Pad Width	W2			2.50
Optional Center Pad Length	T2			2.50
Contact Pad Spacing	C1		3.93	
Contact Pad Spacing	C2		3.93	
Contact Pad Width	X1			0.30
Contact Pad Length	Y1			0.73
Distance Between Pads	G	0.20		

Notes:

1. Dimensioning and tolerancing per ASME Y14.5M

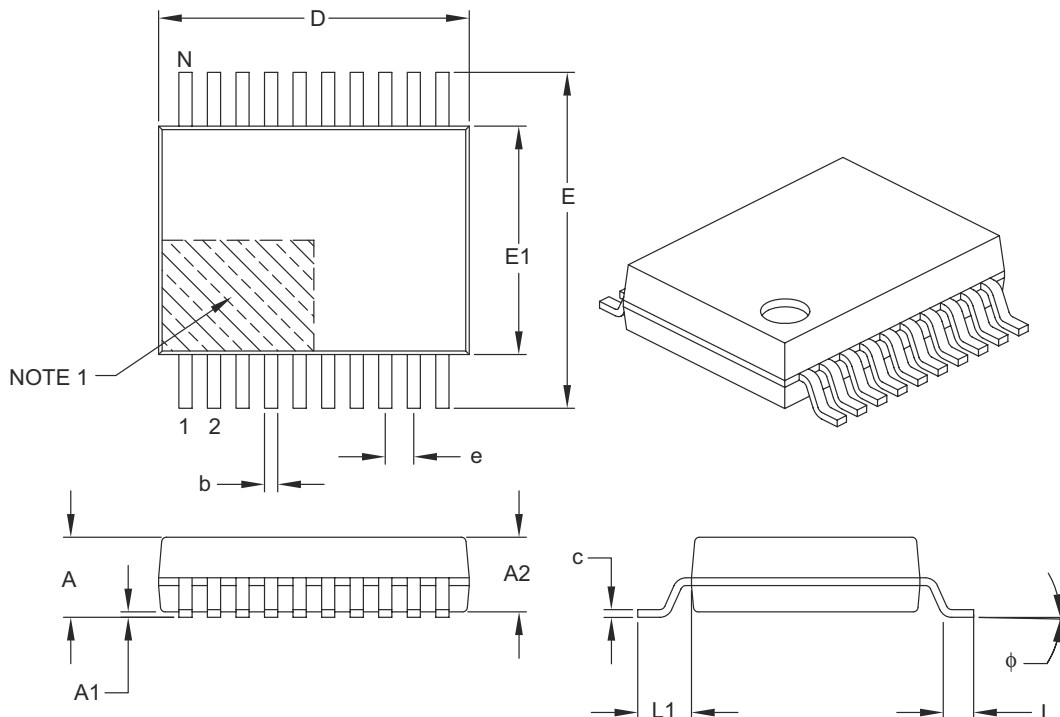
BSC: Basic Dimension. Theoretically exact value shown without tolerances.

Microchip Technology Drawing No. C04-2126A

# MCP3911

## 20-Lead Plastic Shrink Small Outline (SS) – 5.30 mm Body [SSOP]

**Note:** For the most current package drawings, please see the Microchip Packaging Specification located at <http://www.microchip.com/packaging>



Dimension Limits	Units	MILLIMETERS		
		MIN	NOM	MAX
Number of Pins	N	20		
Pitch	e	0.65 BSC		
Overall Height	A	–	–	2.00
Molded Package Thickness	A2	1.65	1.75	1.85
Standoff	A1	0.05	–	–
Overall Width	E	7.40	7.80	8.20
Molded Package Width	E1	5.00	5.30	5.60
Overall Length	D	6.90	7.20	7.50
Foot Length	L	0.55	0.75	0.95
Footprint	L1	1.25 REF		
Lead Thickness	c	0.09	–	0.25
Foot Angle	$\phi$	0°	4°	8°
Lead Width	b	0.22	–	0.38

**Notes:**

- Pin 1 visual index feature may vary, but must be located within the hatched area.
- Dimensions D and E1 do not include mold flash or protrusions. Mold flash or protrusions shall not exceed 0.20 mm per side.
- Dimensioning and tolerancing per ASME Y14.5M.

BSC: Basic Dimension. Theoretically exact value shown without tolerances.

REF: Reference Dimension, usually without tolerance, for information purposes only.

Microchip Technology Drawing C04-072B

## APPENDIX A: REVISION HISTORY

### Revision A (March 2012)

- Original Release of this Document.

# MCP3911

---

NOTES:

## PRODUCT IDENTIFICATION SYSTEM

To order or obtain information, e.g., on pricing or delivery, refer to the factory or the listed sales office.

<u>PART NO.</u>	<u>XX</u>	<u>X</u>	<u>X</u>	<u>XX</u>
Device	Address Options	Tape and Reel	Temperature Range	Package
Device:	MCP3911A0: Two Channel Analog Font End Converter			
Address Options:	XX	A6	A5	
	A0*	= 0	0	
	A1	= 0	1	
	A2	= 1	0	
	A3	= 1	1	
	* Default option. Contact Microchip factory for other address options			
Tape and Reel:	T	=	Tape and Reel	
Temperature Range:	E	=	-40°C to +125°C	
Package:	ML	=	Plastic Quad Flat No Lead Package (QFN)	
	SS	=	Small Shrink Output Package (SSOP-20)	

**Examples:**

a) MCP3911A0-E/ML: Extended Temperature, Two Channel Analog Front End Converter, 20LD QFN package.

b) MCP3911A0T-E/ML: Tape and Reel, Extended Temperature, Two Channel Analog Front End Converter, 20LD QFN package.

c) MCP3911A0-E/SS: Extended Temperature, Two Channel Analog Front End Converter, 20LD SSOP package.

d) MCP3911A0T-E/SS: Tape and Reel, Extended Temperature, Two Channel Analog Front End Converter, 20LD SSOP package.

# MCP3911

---

NOTES:

---

**Note the following details of the code protection feature on Microchip devices:**

- Microchip products meet the specification contained in their particular Microchip Data Sheet.
- Microchip believes that its family of products is one of the most secure families of its kind on the market today, when used in the intended manner and under normal conditions.
- There are dishonest and possibly illegal methods used to breach the code protection feature. All of these methods, to our knowledge, require using the Microchip products in a manner outside the operating specifications contained in Microchip's Data Sheets. Most likely, the person doing so is engaged in theft of intellectual property.
- Microchip is willing to work with the customer who is concerned about the integrity of their code.
- Neither Microchip nor any other semiconductor manufacturer can guarantee the security of their code. Code protection does not mean that we are guaranteeing the product as “unbreakable.”

Code protection is constantly evolving. We at Microchip are committed to continuously improving the code protection features of our products. Attempts to break Microchip's code protection feature may be a violation of the Digital Millennium Copyright Act. If such acts allow unauthorized access to your software or other copyrighted work, you may have a right to sue for relief under that Act.

---

Information contained in this publication regarding device applications and the like is provided only for your convenience and may be superseded by updates. It is your responsibility to ensure that your application meets with your specifications. MICROCHIP MAKES NO REPRESENTATIONS OR WARRANTIES OF ANY KIND WHETHER EXPRESS OR IMPLIED, WRITTEN OR ORAL, STATUTORY OR OTHERWISE, RELATED TO THE INFORMATION, INCLUDING BUT NOT LIMITED TO ITS CONDITION, QUALITY, PERFORMANCE, MERCHANTABILITY OR FITNESS FOR PURPOSE. Microchip disclaims all liability arising from this information and its use. Use of Microchip devices in life support and/or safety applications is entirely at the buyer's risk, and the buyer agrees to defend, indemnify and hold harmless Microchip from any and all damages, claims, suits, or expenses resulting from such use. No licenses are conveyed, implicitly or otherwise, under any Microchip intellectual property rights.

**Trademarks**

The Microchip name and logo, the Microchip logo, dsPIC, KEELOQ, KEELOQ logo, MPLAB, PIC, PICmicro, PICSTART, PIC<sup>32</sup> logo, rfPIC and UNI/O are registered trademarks of Microchip Technology Incorporated in the U.S.A. and other countries.

FilterLab, Hampshire, HI-TECH C, Linear Active Thermistor, MXDEV, MXLAB, SEEVAL and The Embedded Control Solutions Company are registered trademarks of Microchip Technology Incorporated in the U.S.A.

Analog-for-the-Digital Age, Application Maestro, chipKIT, chipKIT logo, CodeGuard, dsPICDEM, dsPICDEM.net, dsPICworks, dsSPEAK, ECAN, ECONOMONITOR, FanSense, HI-TIDE, In-Circuit Serial Programming, ICSP, Mindi, MiWi, MPASM, MPLAB Certified logo, MPLIB, MPLINK, mTouch, Omniscient Code Generation, PICC, PICC-18, PICDEM, PICDEM.net, PICKit, PICtail, REAL ICE, rfLAB, Select Mode, Total Endurance, TSHARC, UniWinDriver, WiperLock and ZENA are trademarks of Microchip Technology Incorporated in the U.S.A. and other countries.

SQTP is a service mark of Microchip Technology Incorporated in the U.S.A.

All other trademarks mentioned herein are property of their respective companies.

© 2012, Microchip Technology Incorporated, Printed in the U.S.A., All Rights Reserved.

 Printed on recycled paper.

ISBN: 978-1-62076-094-9

*Microchip received ISO/TS-16949:2009 certification for its worldwide headquarters, design and wafer fabrication facilities in Chandler and Tempe, Arizona; Gresham, Oregon and design centers in California and India. The Company's quality system processes and procedures are for its PIC<sup>®</sup> MCUs and dsPIC<sup>®</sup> DSCs, KEELOQ<sup>®</sup> code hopping devices, Serial EEPROMs, microperipherals, nonvolatile memory and analog products. In addition, Microchip's quality system for the design and manufacture of development systems is ISO 9001:2000 certified.*

**QUALITY MANAGEMENT SYSTEM**  
**CERTIFIED BY DNV**  
**== ISO/TS 16949:2009 ==**



# MICROCHIP

## Worldwide Sales and Service

### AMERICAS

**Corporate Office**  
2355 West Chandler Blvd.  
Chandler, AZ 85224-6199  
Tel: 480-792-7200  
Fax: 480-792-7277  
Technical Support:  
<http://www.microchip.com/support>  
Web Address:  
[www.microchip.com](http://www.microchip.com)

**Atlanta**  
Duluth, GA  
Tel: 678-957-9614  
Fax: 678-957-1455

**Boston**  
Westborough, MA  
Tel: 774-760-0087  
Fax: 774-760-0088

**Chicago**  
Itasca, IL  
Tel: 630-285-0071  
Fax: 630-285-0075

**Cleveland**  
Independence, OH  
Tel: 216-447-0464  
Fax: 216-447-0643

**Dallas**  
Addison, TX  
Tel: 972-818-7423  
Fax: 972-818-2924

**Detroit**  
Farmington Hills, MI  
Tel: 248-538-2250  
Fax: 248-538-2260

**Indianapolis**  
Noblesville, IN  
Tel: 317-773-8323  
Fax: 317-773-5453

**Los Angeles**  
Mission Viejo, CA  
Tel: 949-462-9523  
Fax: 949-462-9608

**Santa Clara**  
Santa Clara, CA  
Tel: 408-961-6444  
Fax: 408-961-6445

**Toronto**  
Mississauga, Ontario,  
Canada  
Tel: 905-673-0699  
Fax: 905-673-6509

### ASIA/PACIFIC

**Asia Pacific Office**  
Suites 3707-14, 37th Floor  
Tower 6, The Gateway  
Harbour City, Kowloon  
Hong Kong  
Tel: 852-2401-1200  
Fax: 852-2401-3431

**Australia - Sydney**  
Tel: 61-2-9868-6733  
Fax: 61-2-9868-6755

**China - Beijing**  
Tel: 86-10-8569-7000  
Fax: 86-10-8528-2104

**China - Chengdu**  
Tel: 86-28-8665-5511  
Fax: 86-28-8665-7889

**China - Chongqing**  
Tel: 86-23-8980-9588  
Fax: 86-23-8980-9500

**China - Hangzhou**  
Tel: 86-571-2819-3187  
Fax: 86-571-2819-3189

**China - Hong Kong SAR**  
Tel: 852-2401-1200  
Fax: 852-2401-3431

**China - Nanjing**  
Tel: 86-25-8473-2460  
Fax: 86-25-8473-2470

**China - Qingdao**  
Tel: 86-532-8502-7355  
Fax: 86-532-8502-7205

**China - Shanghai**  
Tel: 86-21-5407-5533  
Fax: 86-21-5407-5066

**China - Shenyang**  
Tel: 86-24-2334-2829  
Fax: 86-24-2334-2393

**China - Shenzhen**  
Tel: 86-755-8203-2660  
Fax: 86-755-8203-1760

**China - Wuhan**  
Tel: 86-27-5980-5300  
Fax: 86-27-5980-5118

**China - Xian**  
Tel: 86-29-8833-7252  
Fax: 86-29-8833-7256

**China - Xiamen**  
Tel: 86-592-2388138  
Fax: 86-592-2388130

**China - Zhuhai**  
Tel: 86-756-3210040  
Fax: 86-756-3210049

### ASIA/PACIFIC

**India - Bangalore**  
Tel: 91-80-3090-4444  
Fax: 91-80-3090-4123

**India - New Delhi**  
Tel: 91-11-4160-8631  
Fax: 91-11-4160-8632

**India - Pune**  
Tel: 91-20-2566-1512  
Fax: 91-20-2566-1513

**Japan - Osaka**  
Tel: 81-66-152-7160  
Fax: 81-66-152-9310

**Japan - Yokohama**  
Tel: 81-45-471-6166  
Fax: 81-45-471-6122

**Korea - Daegu**  
Tel: 82-53-744-4301  
Fax: 82-53-744-4302

**Korea - Seoul**  
Tel: 82-2-554-7200  
Fax: 82-2-558-5932 or  
82-2-558-5934

**Malaysia - Kuala Lumpur**  
Tel: 60-3-6201-9857  
Fax: 60-3-6201-9859

**Malaysia - Penang**  
Tel: 60-4-227-8870  
Fax: 60-4-227-4068

**Philippines - Manila**  
Tel: 63-2-634-9065  
Fax: 63-2-634-9069

**Singapore**  
Tel: 65-6334-8870  
Fax: 65-6334-8850

**Taiwan - Hsin Chu**  
Tel: 886-3-5778-366  
Fax: 886-3-5770-955

**Taiwan - Kaohsiung**  
Tel: 886-7-536-4818  
Fax: 886-7-330-9305

**Taiwan - Taipei**  
Tel: 886-2-2500-6610  
Fax: 886-2-2508-0102

**Thailand - Bangkok**  
Tel: 66-2-694-1351  
Fax: 66-2-694-1350

### EUROPE

**Austria - Wels**  
Tel: 43-7242-2244-39  
Fax: 43-7242-2244-393

**Denmark - Copenhagen**  
Tel: 45-4450-2828  
Fax: 45-4485-2829

**France - Paris**  
Tel: 33-1-69-53-63-20  
Fax: 33-1-69-30-90-79

**Germany - Munich**  
Tel: 49-89-627-144-0  
Fax: 49-89-627-144-44

**Italy - Milan**  
Tel: 39-0331-742611  
Fax: 39-0331-466781

**Netherlands - Drunen**  
Tel: 31-416-690399  
Fax: 31-416-690340

**Spain - Madrid**  
Tel: 34-91-708-08-90  
Fax: 34-91-708-08-91

**UK - Wokingham**  
Tel: 44-118-921-5869  
Fax: 44-118-921-5820

11/29/11