

Features

- Guardring for Stress Protection
- Very Low Forward Voltage
- Epoxy Meets UL 94 V-0 @ 0.125 in
- Package Designed for Optimal Automated Board Assembly
- Pb-Free Packages are Available

Mechanical Data

- Reel Options: 3,000 per 7 inch reel/8 mm tape
- Reel Options: 10,000 per 13 inch reel/8 mm tape
- Device Marking: B4
- Polarity Designator: Cathode Band
- Weight: 11.7 mg (approximately)
- Case: Epoxy Molded
- Finish: All External Surfaces Corrosion Resistant and Terminal Leads are Readily Solderable
- Lead and Mounting Surface Temperature for Soldering Purposes: 260°C max. for 10 Seconds

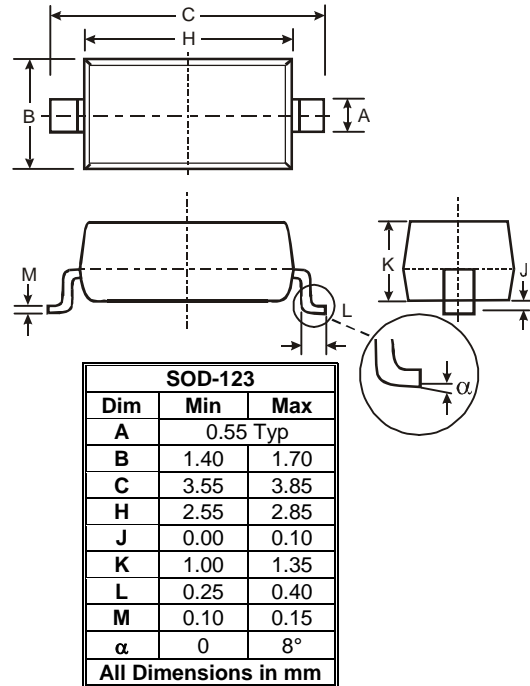

Maximum Ratings and Electrical Characteristics @ T_A = 25°C unless otherwise specified

| Rating | Symbol | Value | | Unit |
|--|--|-----------------------|------------------------|------|
| Peak Repetitive Reverse Voltage Working Peak Reverse Voltage DC Blocking Voltage | V _{RRM} V _{RWM} V _R | 40 | | V |
| Average Rectified Forward Current (At Rated V _R , T _C = 115°C) | I _O | 0.5 | | A |
| Peak Repetitive Forward Current (At Rated V _R , Square Wave, 20 kHz, T _C = 115°C) | I _{FRM} | 1.0 | | A |
| Non-Repetitive Peak Surge Current (Surge Applied at Rated Load Conditions Halfwave, Single Phase, 60 Hz) | I _{FSM} | 5.5 | | A |
| Storage/Operating Case Temperature Range | T _{stg} , T _C | -55 to +150 | | °C |
| Operating Junction Temperature | T _J | -55 to +150 | | °C |
| Voltage Rate of Change (Rated V _R , T _J = 25°C) | dv/dt | 1000 | | V/μs |
| Maximum Instantaneous Forward Voltage (Note 3) (i _F = 0.5 A) (i _F = 1 A) | V _F | T _J = 25°C | T _J = 100°C | V |
| | | 0.51 0.62 | 0.46 0.61 | |
| Maximum Instantaneous Reverse Current (Note 3) (V _R = 40 V) (V _R = 20 V) | I _R | T _J = 25°C | T _J = 100°C | μA |
| | | 20 10 | 13,000 5,000 | |

1. Mounted with minimum recommended pad size, PC Board FR4.
2. 1 inch square pad size (1 X 0.5 inch for each lead) on FR4 board.
3. Pulse Test: Pulse Width ≤ 250 μs, Duty Cycle ≤ 2.0%.

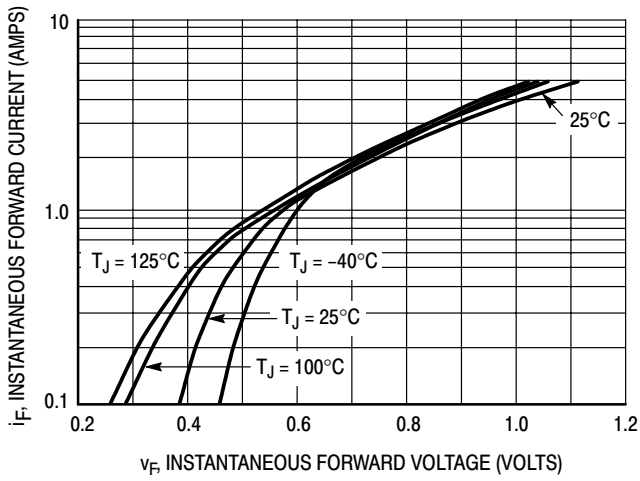

Figure 1. Typical Forward Voltage

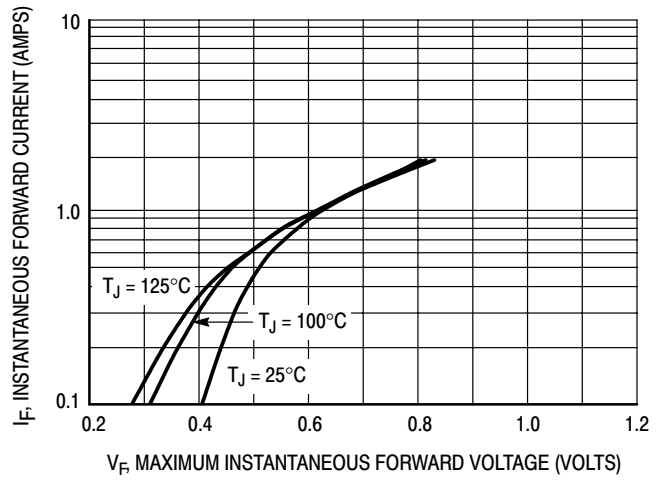

Figure 2. Maximum Forward Voltage

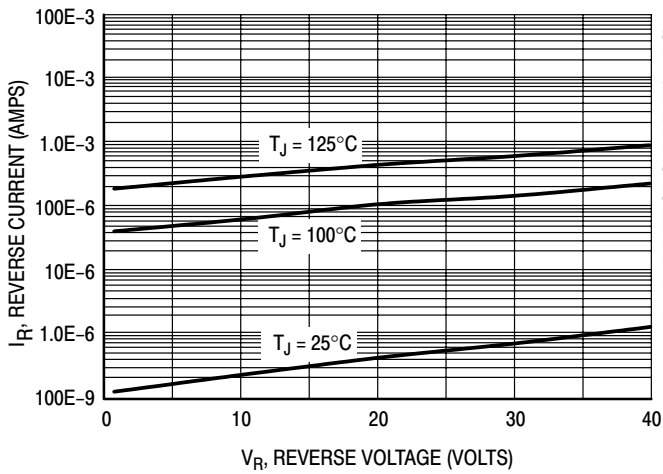

Figure 3. Typical Reverse Current

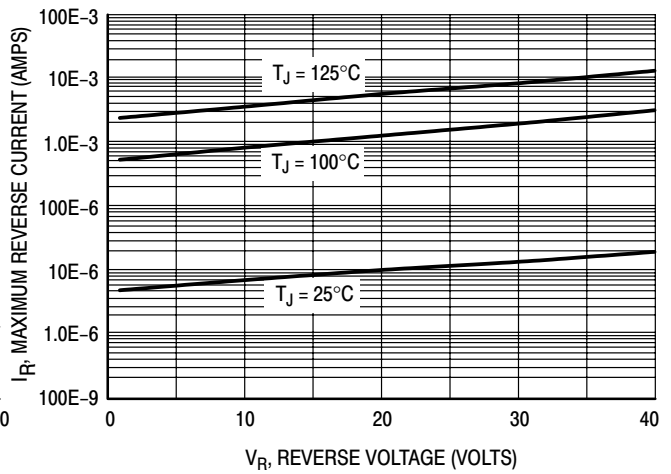

Figure 4. Maximum Reverse Current

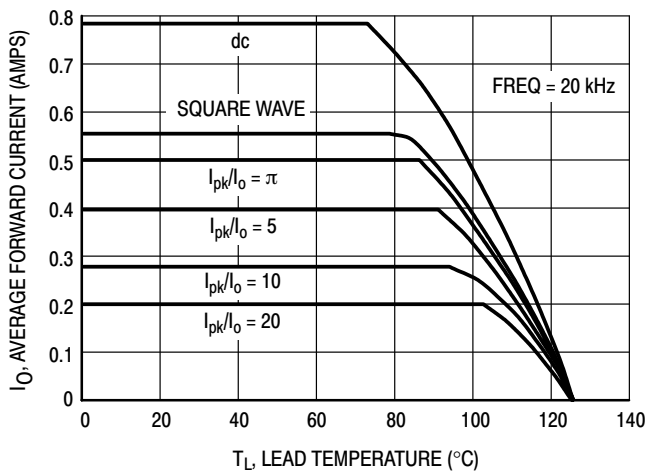

Figure 5. Current Derating

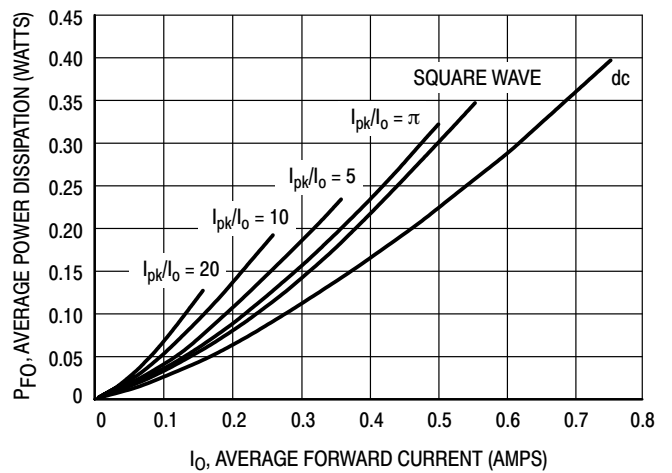

Figure 6. Forward Power Dissipation

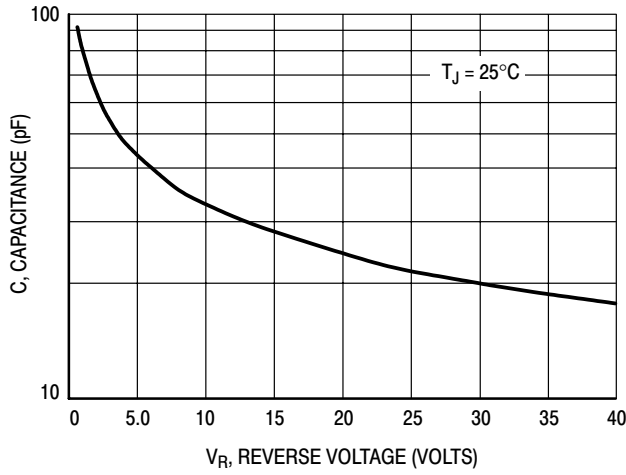

Figure 7. Capacitance

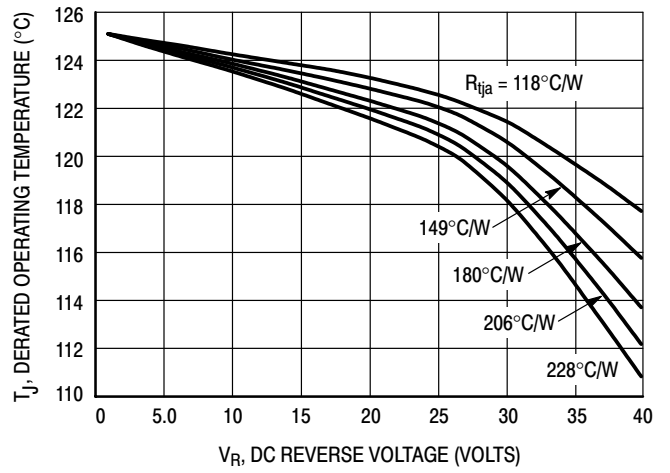

Figure 8. Typical Operating Temperature Derating*

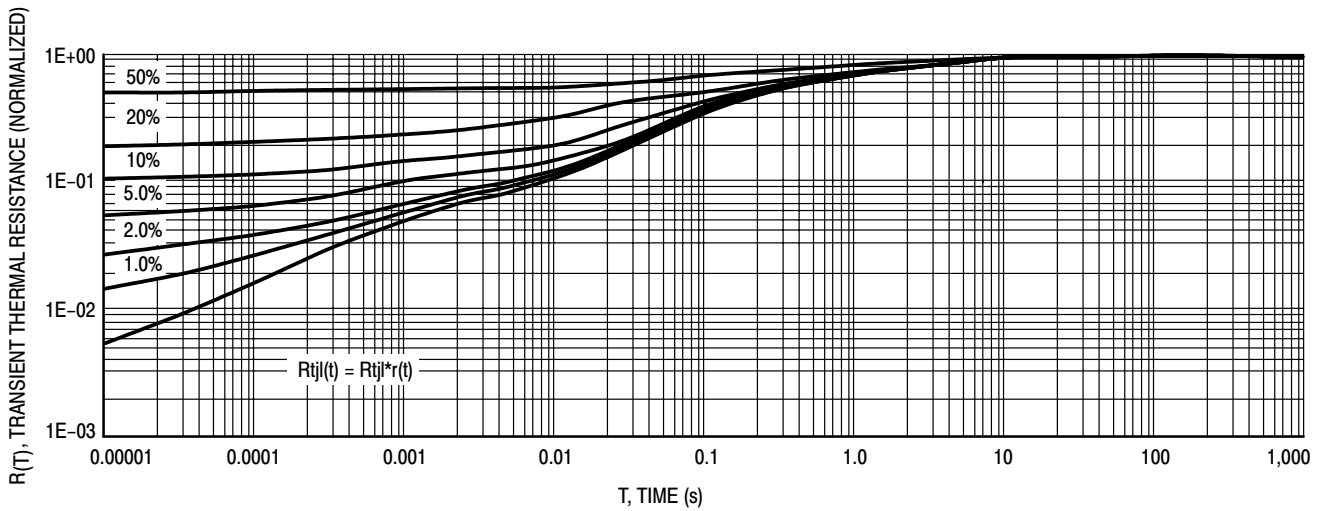

Figure 9. Thermal Response Junction to Lead

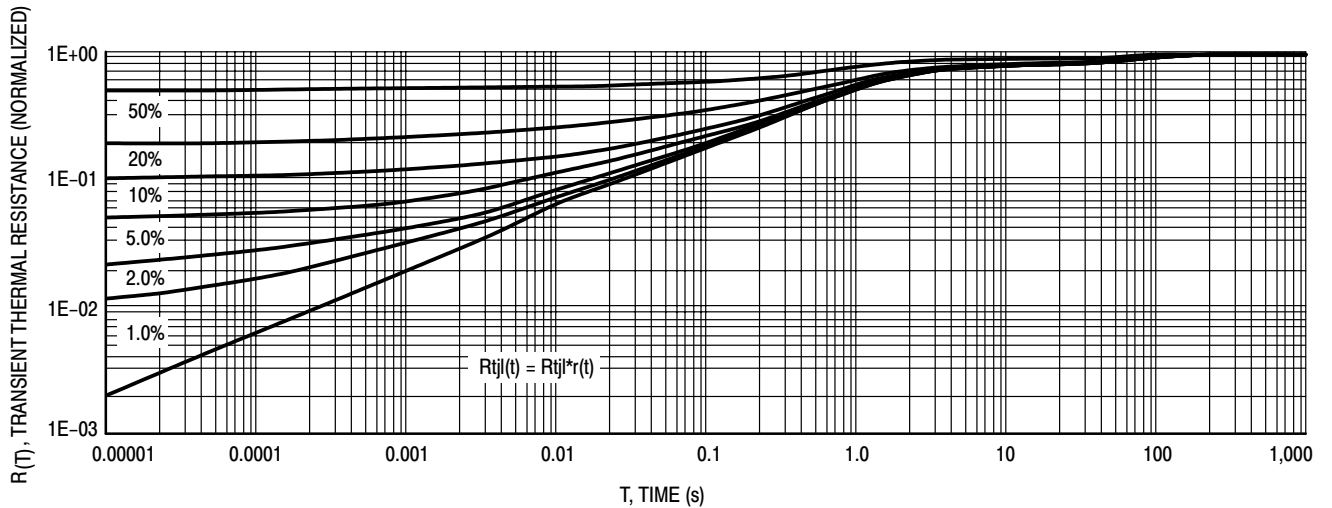

Figure 10. Thermal Response Junction to Ambient