



# 27-Bit, 3MHz-to-35MHz DC-Balanced LVDS Serializer

MAX9217

## General Description

The MAX9217 digital video parallel-to-serial converter serializes 27 bits of parallel data into a serial data stream. Eighteen bits of video data and 9 bits of control data are encoded and multiplexed onto the serial interface, reducing the serial data rate. The data enable input determines when the video or control data is serialized.

The MAX9217 pairs with the MAX9218 deserializer to form a complete digital video serial link. Interconnect can be controlled-impedance PC board traces or twisted-pair cable. Proprietary data encoding reduces EMI and provides DC balance. DC balance allows AC-coupling, providing isolation between the transmitting and receiving ends of the interface. The LVDS output is internally terminated with 100Ω.

ESD tolerance is specified for ISO 10605 with ±10kV contact discharge and ±30kV air discharge.

The MAX9217 operates from a +3.3V core supply and features a separate input supply for interfacing to 1.8V to 3.3V logic levels. This device is available in 48-lead Thin QFN and TQFP packages and is specified from -40°C to +85°C.

## Applications

- Navigation System Display
- In-Vehicle Entertainment System
- Video Camera
- LCD Displays

## Features

- ◆ Proprietary Data Encoding for DC Balance and Reduced EMI
- ◆ Control Data Sent During Video Blanking
- ◆ Five Control Data Inputs Are Single-Bit-Error Tolerant
- ◆ Programmable Phase-Shifted LVDS Signaling Reduces EMI
- ◆ Output Common-Mode Filter Reduces EMI
- ◆ Greater than 10m STP Cable Drive
- ◆ Wide ±2% Reference Clock Tolerance
- ◆ ISO 10605 ESD Protection
- ◆ Separate Input Supply Allows Interface to 1.8V to 3.3V Logic
- ◆ +3.3V Core Supply
- ◆ Space-Saving Thin QFN and TQFP Packages
- ◆ -40°C to +85°C Operating Temperature

## Ordering Information

PART	TEMP RANGE	PIN-PACKAGE	PKG CODE
MAX9217ECM	-40°C to +85°C	48 TQFP	C48-5
MAX9217ETM	-40°C to +85°C	48 Thin QFN-EP*	T4866-1

\*EP = Exposed pad.

## Pin Configurations

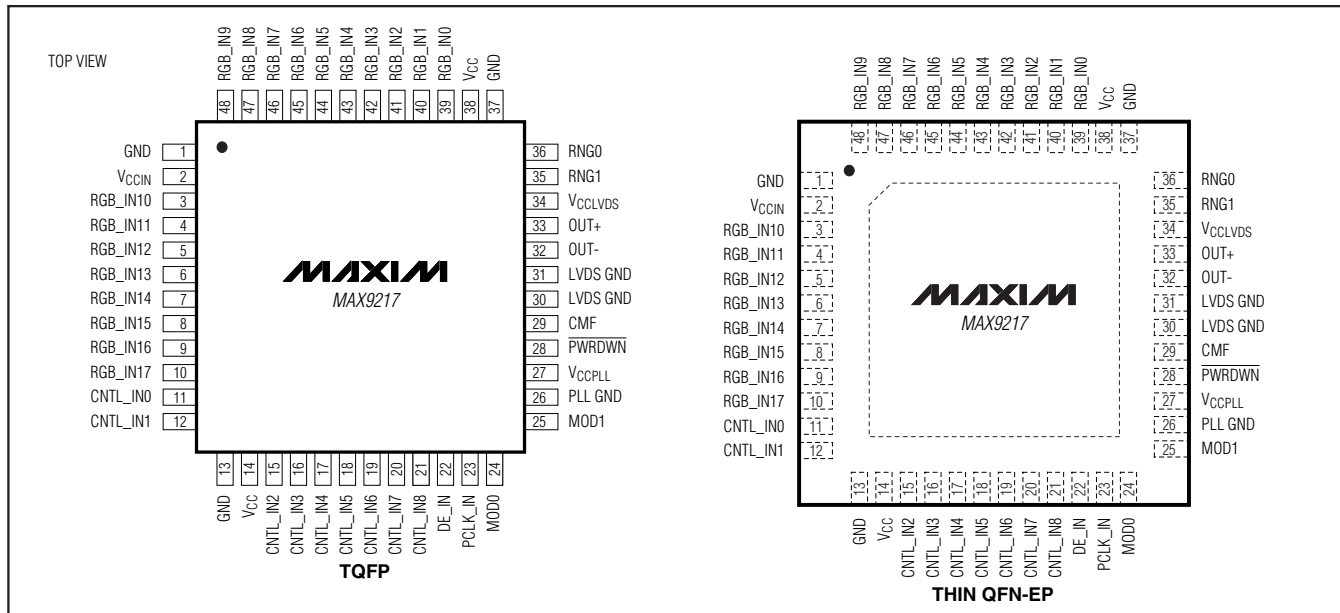

For pricing, delivery, and ordering information, please contact Maxim/Dallas Direct! at 1-888-629-4642, or visit Maxim's website at [www.maxim-ic.com](http://www.maxim-ic.com).

# 27-Bit, 3MHz-to-35MHz DC-Balanced LVDS Serializer

## ABSOLUTE MAXIMUM RATINGS

V <sub>CC_</sub> to GND	-0.5V to +4.0V
Any Ground to Any Ground	-0.5V to +0.5V
OUT+, OUT- to LVDS GND	-0.5V to +4.0V
OUT+, OUT- Short Circuit to LVDS GND or V <sub>CCLVDS</sub>	Continuous
OUT+, OUT- Short Through 0.125μF (or smaller), 25V Series Capacitor	-0.5V to +16V
RGB_IN[17:0], CNTL_IN[8:0], DE_IN, RNG0, RNG1, MOD0, MOD1, PCLK_IN, PWRDWN, CMF to GND	-0.5V to (V <sub>CCIN</sub> + 0.5V)
Continuous Power Dissipation (T <sub>A</sub> = +70°C)	
48-Lead TQFP (derate 20.8mW/°C above +70°C)	1667mW
48-Lead Thin QFN (derate 37mW/°C above +70°C)	2963mW

### ESD Protection

Human Body Model (R <sub>D</sub> = 1.5kΩ, C <sub>S</sub> = 100pF)	
All Pins to GND	±2kV
ISO 10605 (R <sub>D</sub> = 2kΩ, C <sub>S</sub> = 330pF)	
Contact Discharge (OUT+, OUT-) to GND	±10kV
Air Discharge (OUT+, OUT-) to GND	±30kV
Storage Temperature Range	-65°C to +150°C
Junction Temperature	+150°C
Lead Temperature (soldering, 10s)	+300°C

Stresses beyond those listed under "Absolute Maximum Ratings" may cause permanent damage to the device. These are stress ratings only, and functional operation of the device at these or any other conditions beyond those indicated in the operational sections of the specifications is not implied. Exposure to absolute maximum rating conditions for extended periods may affect device reliability.

## DC ELECTRICAL CHARACTERISTICS

(V<sub>CC\_</sub> = +3.0V to +3.6V, R<sub>L</sub> = 100Ω ±1%, PWRDWN = high, T<sub>A</sub> = -40°C to +85°C, unless otherwise noted. Typical values are at V<sub>CC\_</sub> = +3.3V, T<sub>A</sub> = +25°C.) (Notes 1, 2)

PARAMETER	SYMBOL	CONDITIONS	MIN	TYP	MAX	UNITS
<b>SINGLE-ENDED INPUTS (RGB_IN[17:0], CNTL_IN[8:0], DE_IN, PCLK_IN, PWRDWN, RNG_, MOD_)</b>						
High-Level Input Voltage	V <sub>IH</sub>	V <sub>CCIN</sub> = 1.71V to <3V	0.65V <sub>CCIN</sub>	V <sub>CCIN</sub> + 0.3		V
			2	V <sub>CCIN</sub> + 0.3		
Low-Level Input Voltage	V <sub>IL</sub>	V <sub>CCIN</sub> = 1.71V to <3V	-0.3	0.3V <sub>CCIN</sub>		V
			-0.3	+0.8		
Input Current	I <sub>IN</sub>	V <sub>IN</sub> = -0.3V to (V <sub>CCIN</sub> + 0.3V), V <sub>CCIN</sub> = 1.71V to 3.6V, PWRDWN = high or low	-70		+70	μA
Input Clamp Voltage	V <sub>CL</sub>	I <sub>CL</sub> = -18mA			-1.5	V
<b>LVDS OUTPUTS (OUT+, OUT-)</b>						
Differential Output Voltage	V <sub>OD</sub>	Figure 1	250	335	450	mV
Change in V <sub>OD</sub> Between Complementary Output States	ΔV <sub>OD</sub>	Figure 1			20	mV
Common-Mode Voltage	V <sub>OS</sub>	Figure 1	1.125	1.29	1.375	V
Change in V <sub>OS</sub> Between Complementary Output States	ΔV <sub>OS</sub>	Figure 1			20	mV
Output Short-Circuit Current	I <sub>OS</sub>	V <sub>OUT+</sub> or V <sub>OUT-</sub> = 0 or 3.6V	-15	±8	+15	mA
Magnitude of Differential Output Short-Circuit Current	I <sub>OSD</sub>	V <sub>OD</sub> = 0		5.5	15	mA
Output High-Impedance Current	I <sub>OZ</sub>	PWRDWN = low or V <sub>CC_</sub> = 0	OUT+ = 0, OUT- = 3.6V			μA
			OUT+ = 3.6V, OUT- = 0	-1		

# 27-Bit, 3MHz-to-35MHz DC-Balanced LVDS Serializer

MAX9217

## DC ELECTRICAL CHARACTERISTICS (continued)

( $V_{CC\_} = +3.0V$  to  $+3.6V$ ,  $R_L = 100\Omega \pm 1\%$ ,  $\overline{PWRDWN} = \text{high}$ ,  $T_A = -40^\circ\text{C}$  to  $+85^\circ\text{C}$ , unless otherwise noted. Typical values are at  $V_{CC\_} = +3.3V$ ,  $T_A = +25^\circ\text{C}$ .) (Notes 1, 2)

PARAMETER	SYMBOL	CONDITIONS	MIN	TYP	MAX	UNITS
Differential Output Resistance	$R_O$		78	110	147	$\Omega$
Worst-Case Supply Current	$I_{CCW}$	$R_L = 100\Omega \pm 1\%$ , $C_L = 5\text{pF}$ , continuous 10 transition words, modulation off	3MHz	15	25	mA
			5MHz	18	25	
			10MHz	23	28	
			20MHz	33	39	
			35MHz	50	70	
Power-Down Supply Current	$I_{CCZ}$	(Note 3)			50	$\mu\text{A}$

## AC ELECTRICAL CHARACTERISTICS

( $V_{CC\_} = +3.0V$  to  $+3.6V$ ,  $R_L = 100\Omega \pm 1\%$ ,  $C_L = 5\text{pF}$ ,  $\overline{PWRDWN} = \text{high}$ ,  $T_A = -40^\circ\text{C}$  to  $+85^\circ\text{C}$ , unless otherwise noted. Typical values are at  $V_{CC\_} = +3.3V$ ,  $T_A = +25^\circ\text{C}$ .) (Note 4)

PARAMETER	SYMBOL	CONDITIONS	MIN	TYP	MAX	UNITS
<b>PCLK_IN TIMING REQUIREMENTS</b>						
Clock Period	$t_T$	Figure 2	28.57		333.00	ns
Clock Frequency	$f_{\text{CLK}}$		3		35	MHz
Clock Frequency Difference from Deserializer Reference Clock	$\Delta f_{\text{CLK}}$		-2		+2	%
Clock Duty Cycle	DC	$t_{\text{HIGH}}/t_T$ or $t_{\text{LOW}}/t_T$ , Figure 2	35	50	65	%
Clock Transition Time	$t_R, t_F$	Figure 2			2.5	ns
<b>SWITCHING CHARACTERISTICS</b>						
Output Rise Time	$t_{\text{RISE}}$	20% to 80%, $V_{OD} \geq 250\text{mV}$ , modulation off, Figure 3		215	350	ps
Output Fall Time	$t_{\text{FALL}}$	80% to 20%, $V_{OD} \geq 250\text{mV}$ , modulation off, Figure 3		206	350	ps
Input Setup Time	$t_{\text{SET}}$	Figure 4	3			ns
Input Hold Time	$t_{\text{HOLD}}$	Figure 4	3			ns
Serializer Delay	$t_{\text{SD}}$	Figure 5	$3.15 \times t_T$		$3.2 \times t_T$	ns
PLL Lock Time	$t_{\text{LOCK}}$	Figure 6			$16385 \times t_T$	ns
Power-Down Delay	$t_{\text{PD}}$	Figure 7			1	$\mu\text{s}$

# 27-Bit, 3MHz-to-35MHz DC-Balanced LVDS Serializer

## AC ELECTRICAL CHARACTERISTICS (continued)

( $V_{CC\_} = +3.0V$  to  $+3.6V$ ,  $R_L = 100\Omega \pm 1\%$ ,  $C_L = 5pF$ ,  $\overline{PWRDWN} = \text{high}$ ,  $T_A = -40^\circ\text{C}$  to  $+85^\circ\text{C}$ , unless otherwise noted. Typical values are at  $V_{CC\_} = +3.3V$ ,  $T_A = +25^\circ\text{C}$ .) (Note 4)

PARAMETER	SYMBOL	CONDITIONS	MIN	TYP	MAX	UNITS
Peak-to-Peak Output Offset Voltage	$V_{OSp-p}$	700Mbps data rate, CMF open, Figure 8		22	70	mV
		700Mbps data rate, CMF 0.1 $\mu$ F to ground, Figure 8		12	50	

**Note 1:** Current into a pin is defined as positive. Current out of a pin is defined as negative. All voltages are referenced to ground except  $V_{OD}$ ,  $\Delta V_{OD}$ , and  $\Delta V_{OS}$ .

**Note 2:** Maximum and minimum limits over temperature are guaranteed by design and characterization. Devices are production tested at  $T_A = +25^\circ\text{C}$ .

**Note 3:** All LVTTTL/LVCMOS inputs, except  $\overline{PWRDWN}$  at  $\leq 0.3V$  or  $\geq V_{CCIN} - 0.3V$ .  $\overline{PWRDWN}$  is  $\leq 0.3V$ .

**Note 4:** AC parameters are guaranteed by design and characterization and are not production tested. Limits are set at  $\pm 6$  sigma.

## Typical Operating Characteristics

( $T_A = +25^\circ\text{C}$ ,  $V_{CC\_} = +3.3V$ ,  $R_L = 100\Omega$ , modulation off, unless otherwise noted.)

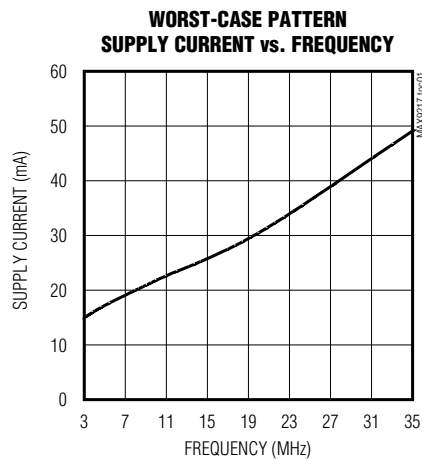

# 27-Bit, 3MHz-to-35MHz DC-Balanced LVDS Serializer

## Pin Description

MAX9217

PIN	NAME	FUNCTION
1, 13, 37	GND	Input Buffer Supply and Digital Supply Ground
2	VCCIN	Input Buffer Supply Voltage. Bypass to GND with 0.1 $\mu$ F and 0.001 $\mu$ F capacitors in parallel as close to the device as possible, with the smallest value capacitor closest to the supply pin.
3–10, 39–48	RGB_IN[17:0]	LVTTTL/LVCMOS Red, Green, and Blue Digital Video Data Inputs. Eighteen data bits are loaded into the input latch on the rising edge of PCLK_IN when DE_IN is high. Internally pulled down to GND.
11, 12, 15–21	CNTL_IN[8:0]	LVTTTL/LVCMOS Control Data Inputs. Control data are latched on the rising edge of PCLK_IN when DE_IN is low. Internally pulled down to GND.
14, 38	VCC	Digital Supply Voltage. Bypass to GND with 0.1 $\mu$ F and 0.001 $\mu$ F capacitors in parallel as close to the device as possible, with the smallest value capacitor closest to the supply pin.
22	DE_IN	LVTTTL/LVCMOS Data Enable Input. Logic-high selects RGB_IN[17:0] to be latched. Logic-low selects CNTL_IN[8:0] to be latched. DE_IN must be switching for proper operation. Internally pulled down to GND.
23	PCLK_IN	LVTTTL/LVCMOS Parallel Clock Input. Latches data and control inputs and provides the PLL reference clock. Internally pulled down to GND.
24	MOD0	LVTTTL/LVCMOS Modulation Rate Input. Selects the phase-modulation step size. Internally pulled down to GND.
25	MOD1	LVTTTL/LVCMOS Modulation Rate Input. Selects the phase-modulation step size. Internally pulled down to GND.
26	PLL GND	PLL Supply Ground
27	VCCPLL	PLL Supply Voltage. Bypass to PLL GND with 0.1 $\mu$ F and 0.001 $\mu$ F capacitors in parallel as close to the device as possible, with the smallest value capacitor closest to the supply pin.
28	PWRDWN	LVTTTL/LVCMOS Power-Down Input. Internally pulled down to GND.
29	CMF	Common-Mode Filter. Optionally connect a capacitor between CMF and ground to filter common-mode switching noise.
30, 31	LVDS GND	LVDS Supply Ground
32	OUT-	Inverting LVDS Serial Data Output
33	OUT+	Noninverting LVDS Serial Data Output
34	VCCLVDS	LVDS Supply Voltage. Bypass to LVDS GND with 0.1 $\mu$ F and 0.001 $\mu$ F capacitors in parallel as close to the device as possible, with the smallest value capacitor closest to the supply pin.
35	RNG1	LVTTTL/LVCMOS Frequency Range Select Input. Set to the frequency range that includes the PCLK_IN frequency as shown in Table 3. Internally pulled down to GND.
36	RNG0	LVTTTL/LVCMOS Frequency Range Select Input. Set to the frequency range that includes the PCLK_IN frequency as shown in Table 3. Internally pulled down to GND.
EP	GND	Exposed Pad (Thin QFN Package Only). Connect Thin QFN exposed pad to PC board GND.

# 27-Bit, 3MHz-to-35MHz DC-Balanced LVDS Serializer

## Functional Diagram

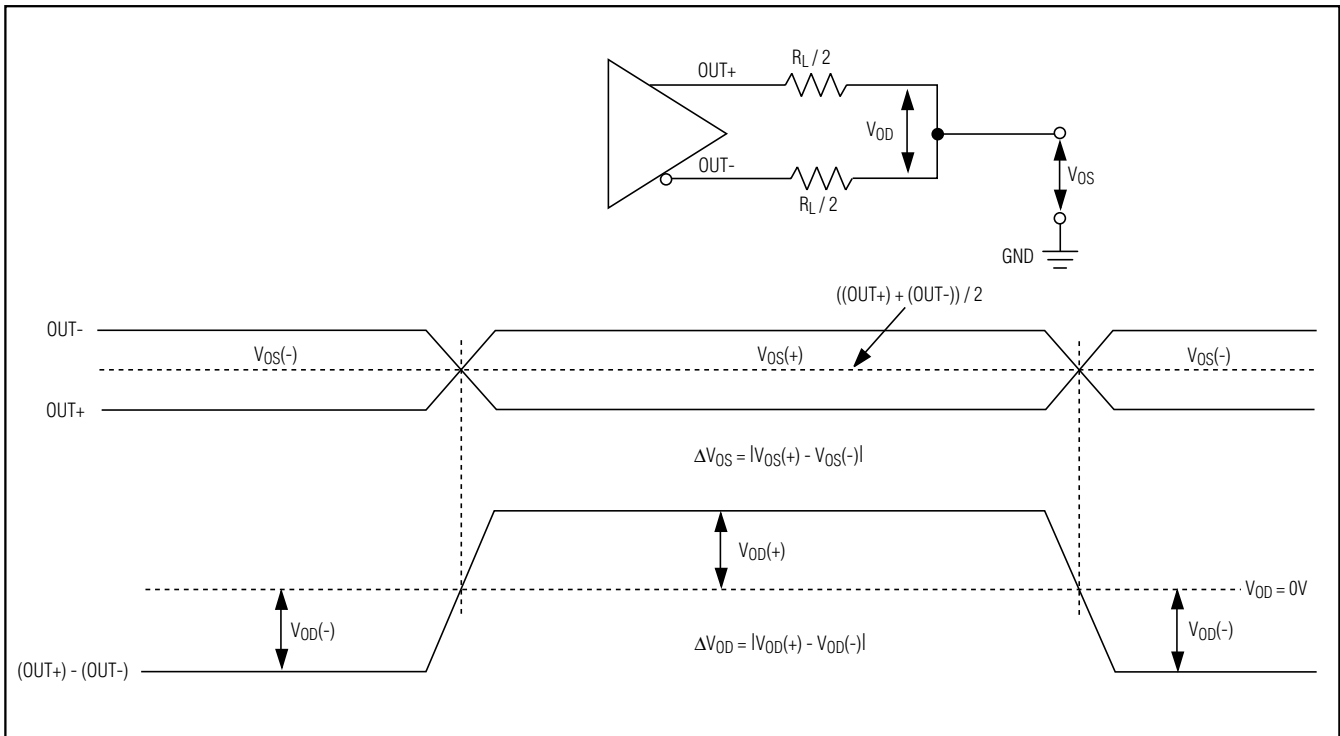
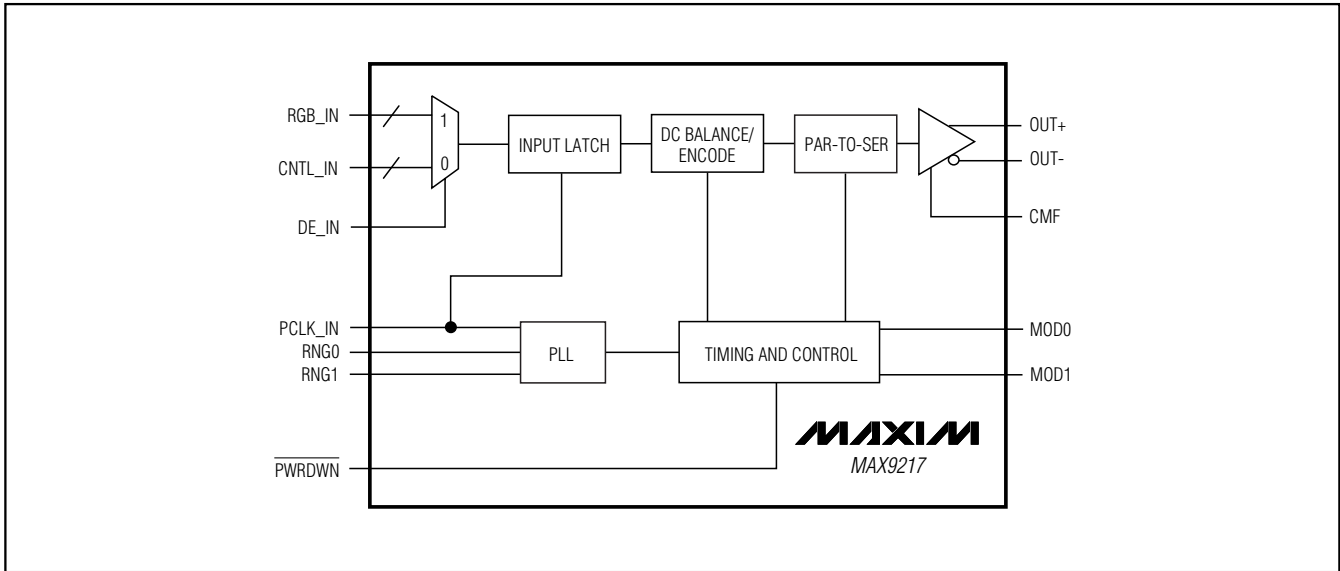

Figure 1. LVDS DC Output Load and Parameters

# 27-Bit, 3MHz-to-35MHz DC-Balanced LVDS Serializer

MAX9217

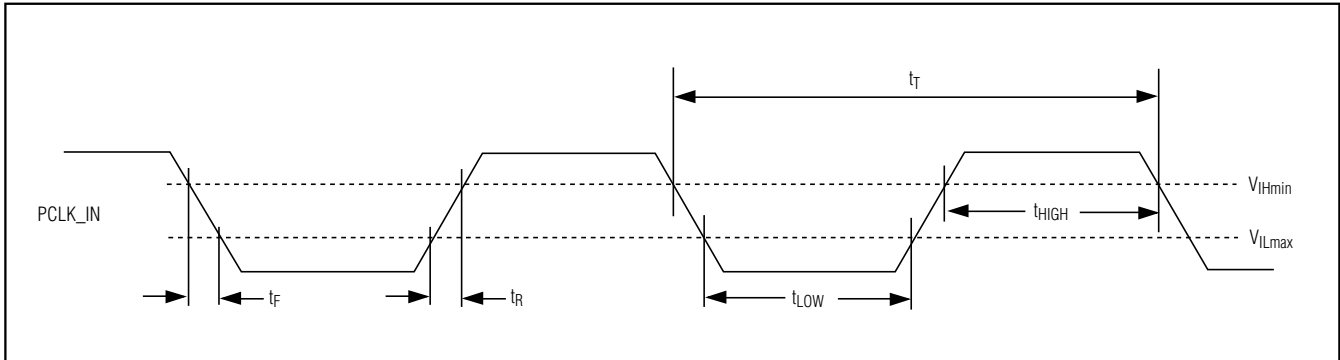

Figure 2. Parallel Clock Requirements

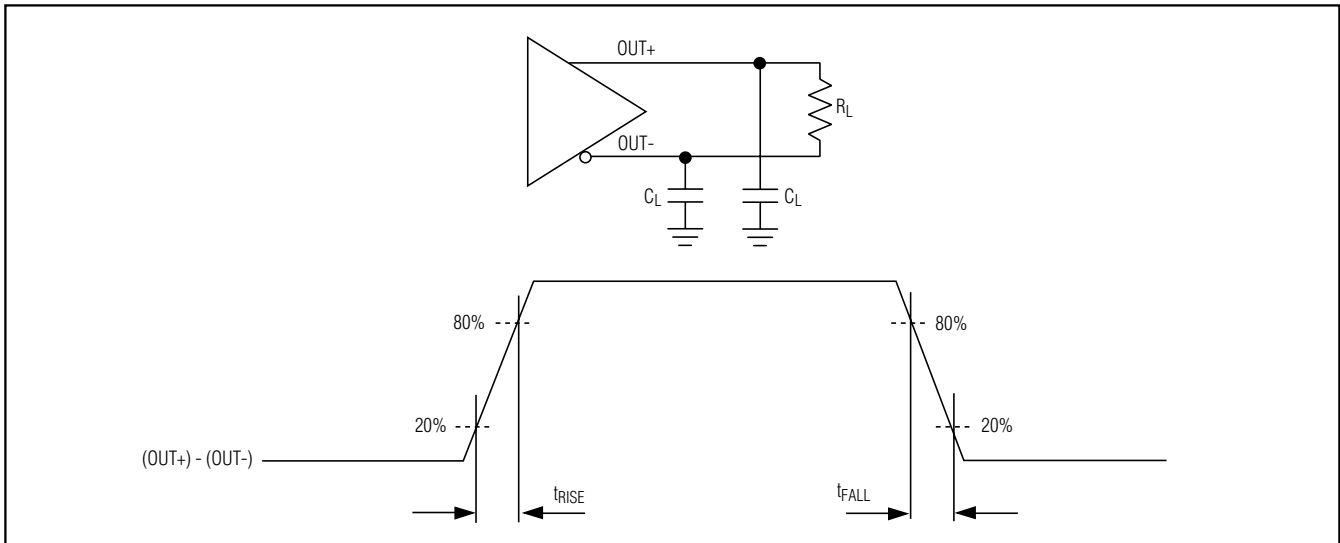

Figure 3. Output Rise and Fall Times

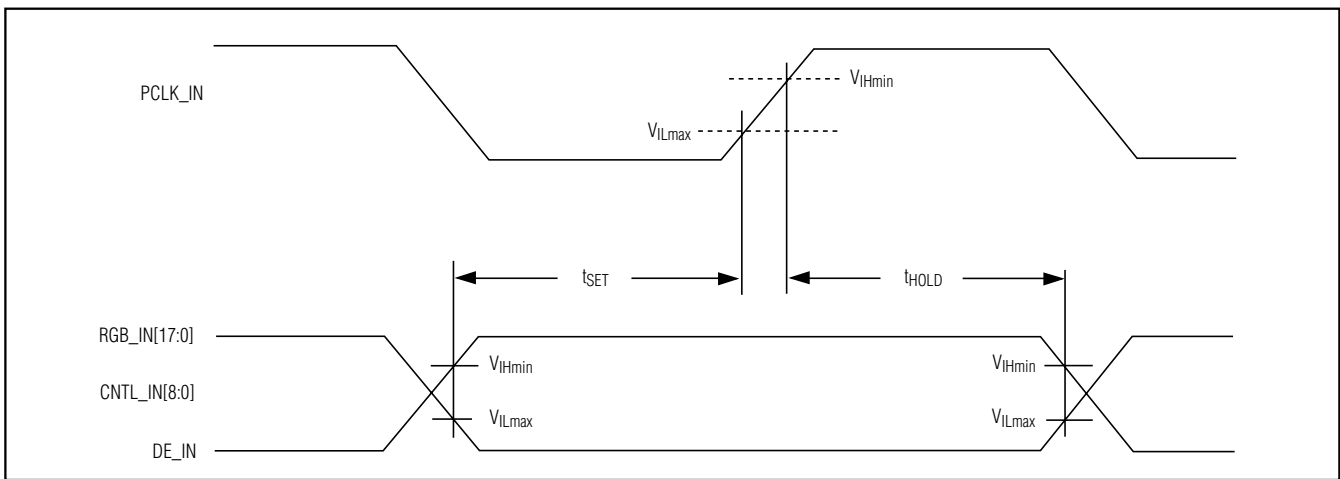

Figure 4. Synchronous Input Timing

# 27-Bit, 3MHz-to-35MHz DC-Balanced LVDS Serializer

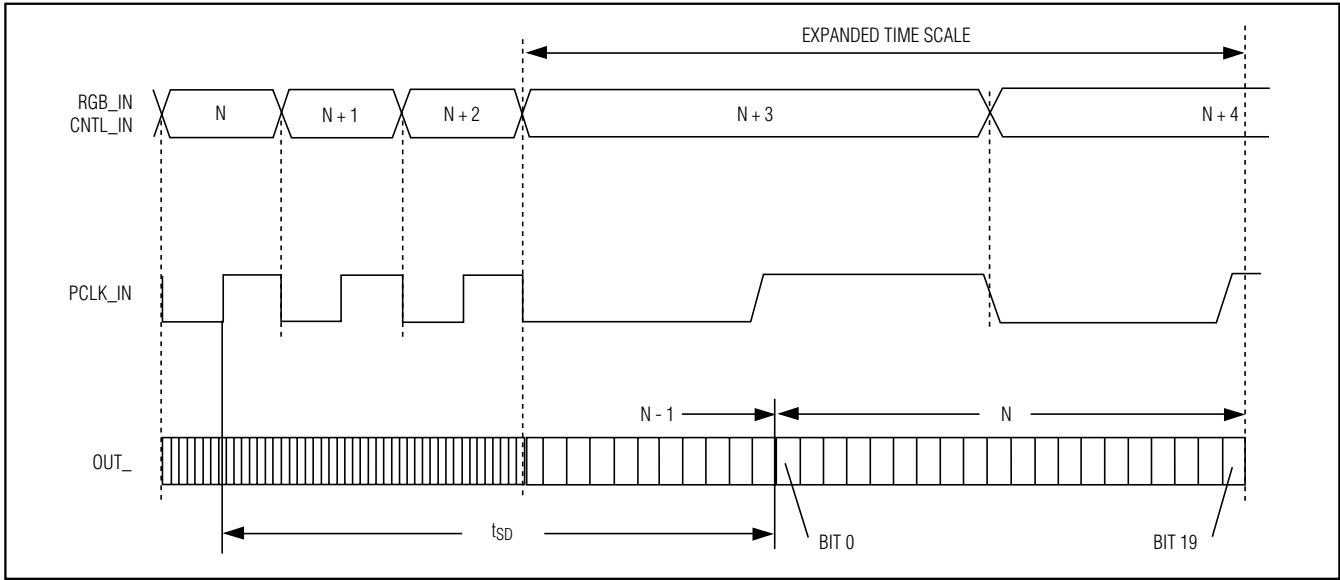

Figure 5. Serializer Delay

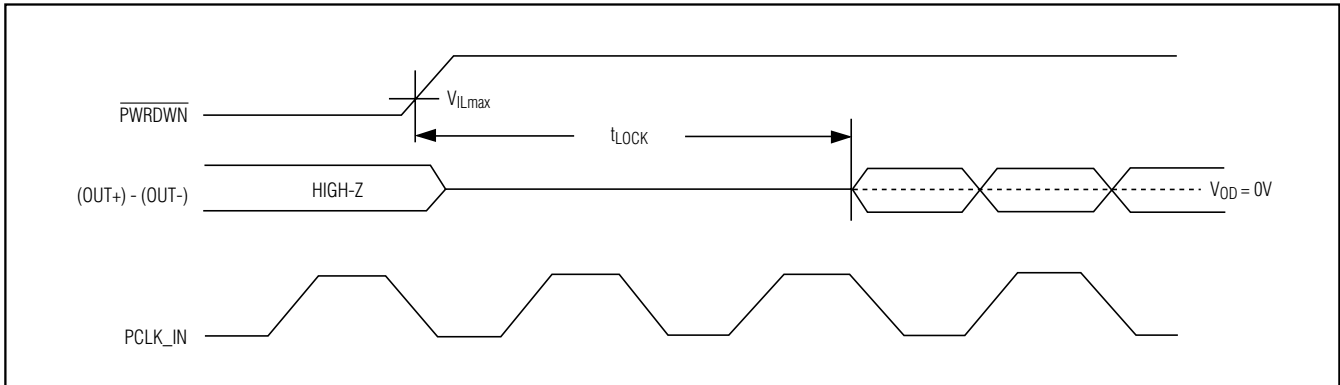

Figure 6. PLL Lock Time

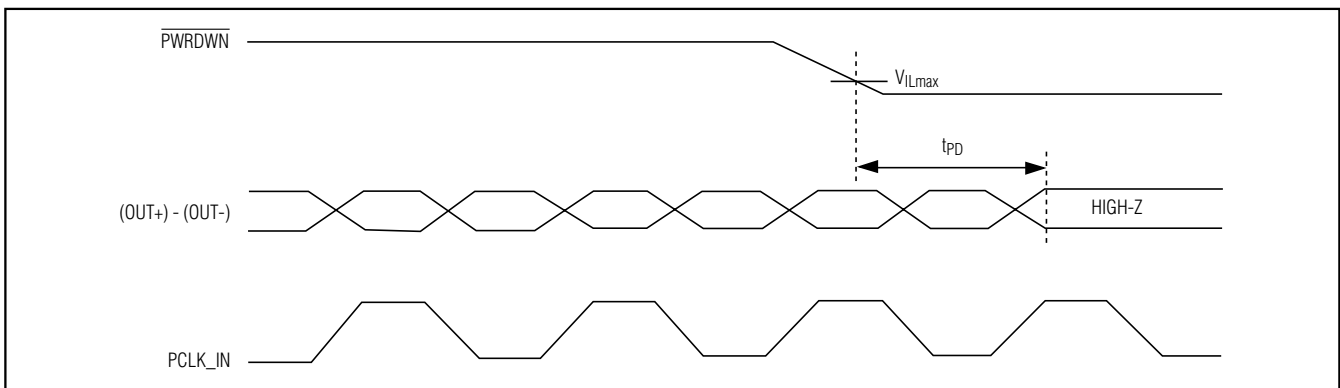

Figure 7. Power-Down Delay



# 27-Bit, 3MHz-to-35MHz DC-Balanced LVDS Serializer

MAX9217

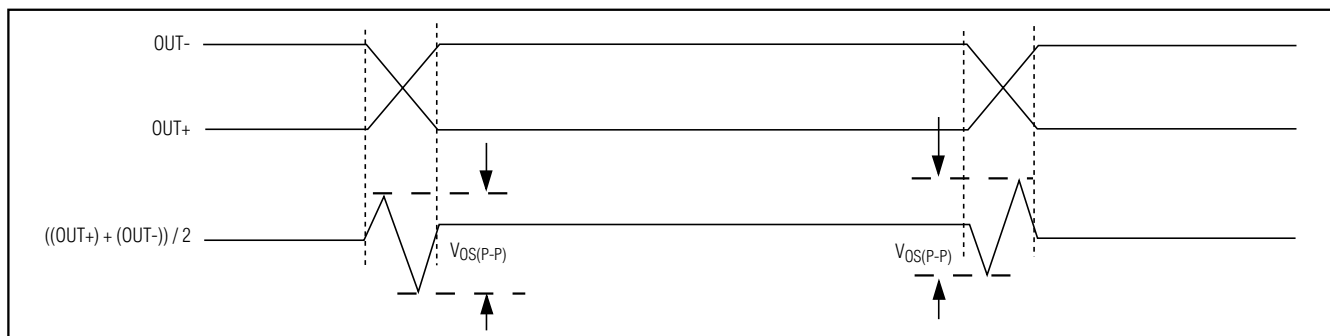

Figure 8. Peak-to-Peak Output Offset Voltage

## Detailed Description

The MAX9217 DC-balanced serializer operates at a parallel clock frequency of 3MHz to 35MHz, serializing 18 bits of parallel video data RGB\_IN[17:0] when the data enable input DE\_IN is high, or 9 bits of parallel control data CNTL\_IN[8:0] when DE\_IN is low. The RGB video input data are encoded using 2 overhead bits, EN0 and EN1, resulting in a serial word length of 20 bits (Table 1). Control inputs are mapped to 19 bits and encoded with 1 overhead bit, EN0, also resulting in a 20-bit serial word. Encoding reduces EMI and main-

tains DC balance across the serial cable. Two transition words, which contain a unique bit sequence, are inserted at the transition boundaries of video-to-control and control-to-video phases.

Control data inputs C0 to C4 are mapped to 3 bits each in the serial control word (Table 2). At the deserializer, 2 or 3 bits at the same state determine the state of the recovered bit, providing single bit-error tolerance for C0 to C4. Control data that may be visible if an error occurs, such as VSYNC and HSYNC, can be connected to these inputs. Control data inputs C5 to C8 are mapped to 1 bit each.

Table 1. Serial Video Phase Word Format

0	1	2	3	4	5	6	7	8	9	10	11	12	13	14	15	16	17	18	19
EN0	EN1	S0	S1	S2	S3	S4	S5	S6	S7	S8	S9	S10	S11	S12	S13	S14	S15	S16	S17

Bit 0 is the LSB and is serialized first. EN[1:0] are encoding bits. S[17:0] are encoded symbols.

Table 2. Serial Control Phase Word Format

0	1	2	3	4	5	6	7	8	9	10	11	12	13	14	15	16	17	18	19
EN0	C0	C0	C0	C1	C1	C1	C2	C2	C2	C3	C3	C3	C4	C4	C4	C5	C6	C7	C8

Bit 0 is the LSB and is serialized first. C[8:0] are the control inputs.

## 27-Bit, 3MHz-to-35MHz DC-Balanced LVDS Serializer

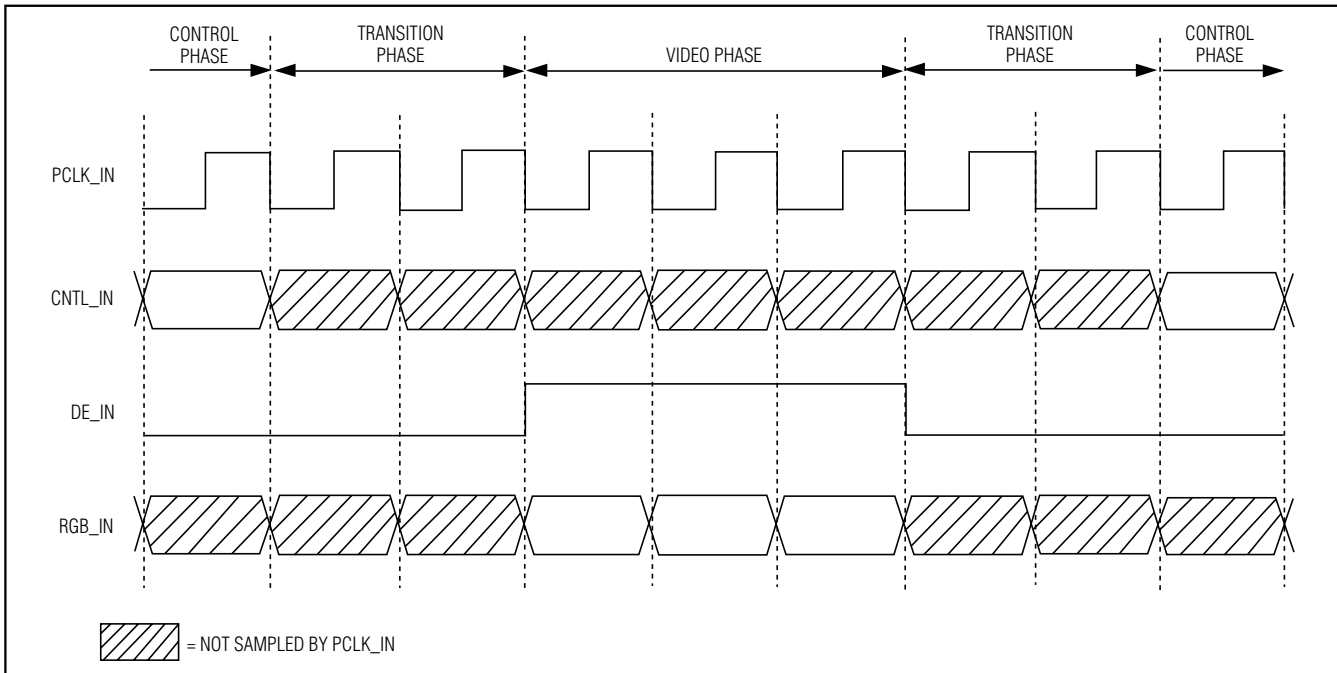

Figure 9. Transition Timing

### Transition Timing

The transition words require interconnect bandwidth and displace control data. Therefore, control data is not sampled (see Figure 9):

- Two clock cycles before DE\_IN goes high.
- During the video phase.
- Two clock cycles after DE\_IN goes low.

The last sampled control data are latched at the deserializer control data outputs during the transition and video phases. Video data are latched at the deserializer RGB data outputs during the transition and control phases.

### Applications Information

#### AC-Coupling Benefits

AC-coupling increases the common-mode voltage to the voltage rating of the capacitor. Two capacitors are sufficient for isolation, but four capacitors—two at the serializer output and two at the deserializer input—provide protection if either end of the cable is shorted to a high voltage. AC-coupling blocks low-frequency ground shifts and common-mode noise. The MAX9217 serializer can also be DC-coupled to the MAX9218 deserializer.

Figure 10 shows an AC-coupled serializer and deserializer with two capacitors per link, and Figure 11 is the AC-coupled serializer and deserializer with four capacitors per link.

#### Selection of AC-Coupling Capacitors

See Figure 12 for calculating the capacitor values for AC-coupling, depending on the parallel clock frequency. The plot shows capacitor values for two- and four-capacitor-per-link systems. For applications using less than 18MHz clock frequency, use 0.125 $\mu$ F capacitors.

#### Frequency-Range Setting RNG[1:0]

The RNG[1:0] inputs select the operating frequency range of the MAX9217 serializer. An external clock within this range is required for operation. Table 3 shows the selectable frequency ranges and corresponding data rates for the MAX9217.

# 27-Bit, 3MHz-to-35MHz DC-Balanced LVDS Serializer

**MAX9217**

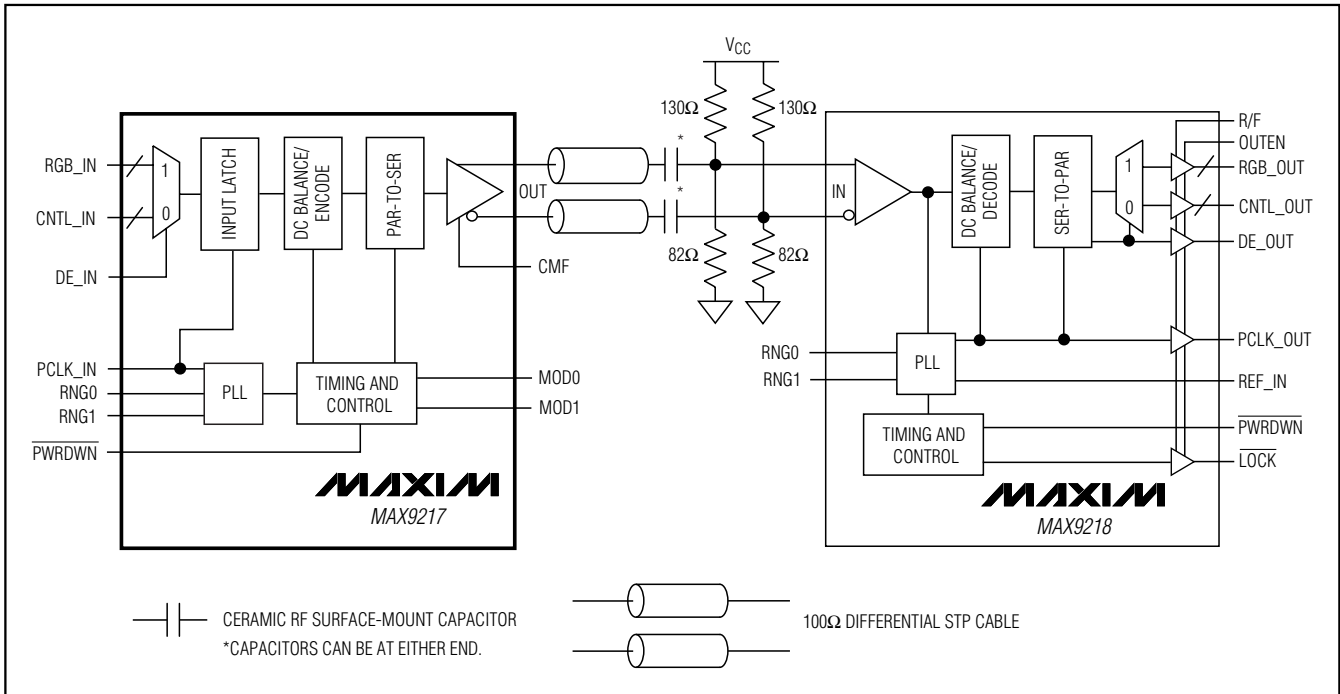

Figure 10. AC-Coupled Serializer and Deserializer with Two Capacitors per Link

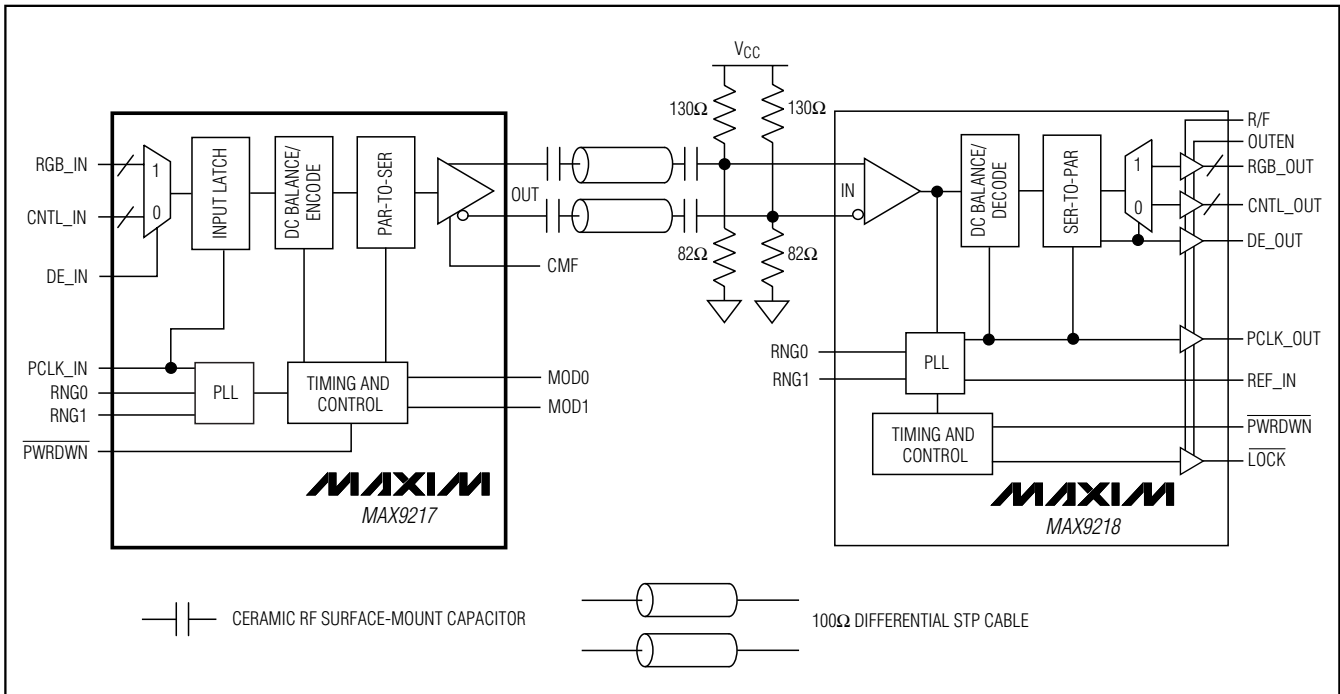

Figure 11. AC-Coupled Serializer and Deserializer with Four Capacitors per Link

# 27-Bit, 3MHz-to-35MHz DC-Balanced LVDS Serializer

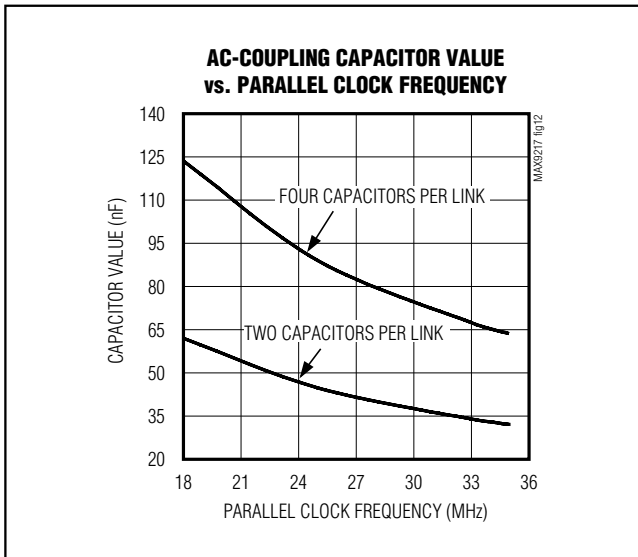

Figure 12. AC-Coupling Capacitor Values vs. Clock Frequency of 18MHz to 35MHz

### Phase-Modulation Setting MOD[1:0]

The serial output edges can be phase shifted (modulated) to reduce EMI. Table 4 shows the available settings for phase modulation. Two shift amplitudes are available. The parallel clock frequency should be 10MHz or higher for the highest amplitude (MOD1 = 1, MOD0 = 0).

Table 3. Parallel Clock Frequency Range Select

RNG1	RNG0	PARALLEL CLOCK (MHz)	SERIAL DATA RATE (Mbps)
0	0	3 to 5	60 to 100
0	1	5 to 10	100 to 200
1	0	10 to 20	200 to 400
1	1	20 to 35	400 to 700

Table 4. Modulation Rate Function Table

MOD1	MOD0	SIMULATED PEAK POWER REDUCTION (dB)
0	0	0 (off)
0	1	2.5
1	0	4.5
1	1	(reserved)

### Termination

The MAX9217 has an integrated 100Ω output-termination resistor. This resistor damps reflections from induced noise and mismatches between the transmission line impedance and termination resistors at the deserializer input. With PWRDWN = low or with the supply off, the output termination is switched out and the LVDS output is high impedance.

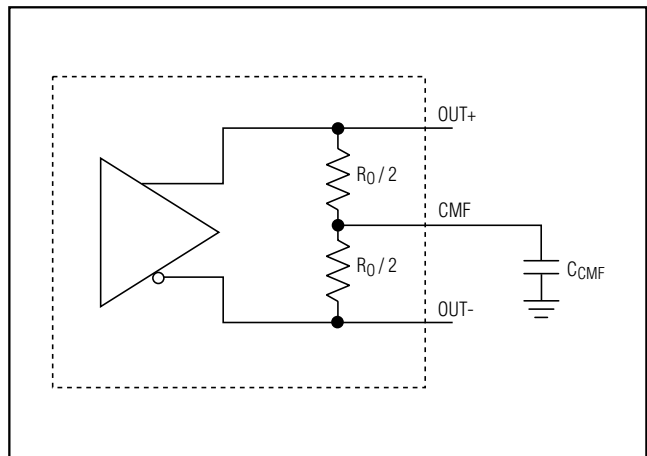

Figure 13. Common-Mode Filter Capacitor Connection

### Common-Mode Filter

The integrated 100Ω output termination is made up of two 50Ω resistors in series. The junction of the resistors is connected to the CMF pin for connecting an optional common-mode filter capacitor. Connect the filter capacitor to ground close to the MAX9217 as shown in Figure 13. The capacitor shunts common-mode switching current to ground to reduce EMI.

# 27-Bit, 3MHz-to-35MHz DC-Balanced LVDS Serializer

MAX9217

## Power-Down and Power-Off

Driving  $\overline{\text{PWRDWN}}$  low stops the PLL, switches out the integrated  $100\Omega$  output termination, and puts the output in high impedance to ground and differentially. With  $\overline{\text{PWRDWN}} \leq 0.3\text{V}$  and all LVTTTL/LVCMOS inputs  $\leq 0.3\text{V}$  or  $\geq V_{\text{CCIN}} - 0.3\text{V}$ , supply current is reduced to  $50\mu\text{A}$  or less.

Driving  $\overline{\text{PWRDWN}}$  high starts PLL lock to PCLK\_IN and switches in the  $100\Omega$  output termination resistor. The LVDS output is not driven until the PLL locks. The LVDS output is high impedance to ground and  $100\Omega$  differential. The  $100\Omega$  integrated termination pulls OUT+ and OUT- together while the PLL is locking so that  $V_{\text{OD}} = 0\text{V}$ .

If  $V_{\text{CC}} = 0$ , the output resistor is switched out and the LVDS outputs are high impedance to ground and differentially.

## PLL Lock Time

The PLL lock time is set by an internal counter. The lock time is 16,385 PCLK\_IN cycles. Power and clock should be stable to meet the lock-time specification.

## Input Buffer Supply

The single-ended inputs (RGB\_IN[17:0], CNTL\_IN[8:0], DE\_IN, RNG0, RNG1, MOD0, MOD1, PCLK\_IN, and  $\overline{\text{PWRDWN}}$ ) are powered from  $V_{\text{CCIN}}$ .  $V_{\text{CCIN}}$  can be connected to a 1.71V to 3.6V supply, allowing logic inputs with a nominal swing of  $V_{\text{CCIN}}$ . If no power is applied to  $V_{\text{CCIN}}$  when power is applied to  $V_{\text{CC}}$ , the inputs are disabled and  $\overline{\text{PWRDWN}}$  is internally driven low, putting the device in the power-down state.

## Power-Supply Circuits and Bypassing

The MAX9217 has isolated on-chip power domains. The digital core supply ( $V_{\text{CC}}$ ) and single-ended input supply ( $V_{\text{CCIN}}$ ) are isolated but have a common ground (GND). The PLL has separate power and ground ( $V_{\text{CCPLL}}$  and  $V_{\text{CCPLL GND}}$ ) and the LVDS input also has separate power and ground ( $V_{\text{CCLVDS}}$  and  $V_{\text{CCLVDS GND}}$ ). The grounds are isolated by diode connections. Bypass each  $V_{\text{CC}}$ ,  $V_{\text{CCIN}}$ ,  $V_{\text{CCPLL}}$ , and  $V_{\text{CCLVDS}}$  pin with high-frequency, surface-mount ceramic  $0.1\mu\text{F}$  and  $0.001\mu\text{F}$  capacitors in parallel as close to the device as possible, with the smallest value capacitor closest to the supply pin.

## LVDS Output

The LVDS output is a current source. The voltage swing is proportional to the termination resistance. The output is rated for a differential load of  $100\Omega \pm 1\%$ .

## Cables and Connectors

Interconnect for LVDS typically has a differential impedance of  $100\Omega$ . Use cables and connectors that have matched differential impedance to minimize impedance discontinuities.

Twisted-pair and shielded twisted-pair cables offer superior signal quality compared to ribbon cable and tend to generate less EMI due to magnetic field canceling effects. Balanced cables pick up noise as common mode, which is rejected by the LVDS receiver.

## 27-Bit, 3MHz-to-35MHz DC-Balanced LVDS Serializer

### Board Layout

Separate the LVTTTL/LVCMOS inputs and LVDS output to prevent crosstalk. A four-layer PC board with separate layers for power, ground, and signals is recommended.

### ESD Protection

The MAX9217 ESD tolerance is rated for Human Body Model and ISO 10605. ISO 10605 specifies ESD tolerance for electronic systems. The Human Body Model discharge components are  $C_S = 100\text{pF}$  and  $R_D = 1.5\text{k}\Omega$  (Figure 14). The ISO 10605 discharge components are  $C_S = 330\text{pF}$  and  $R_D = 2\text{k}\Omega$  (Figure 15).

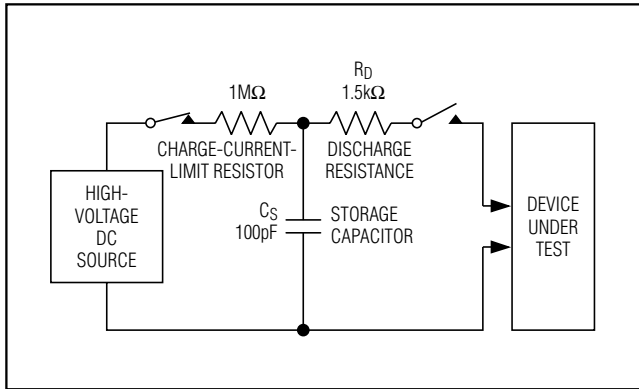

Figure 14. Human Body ESD Test Circuit

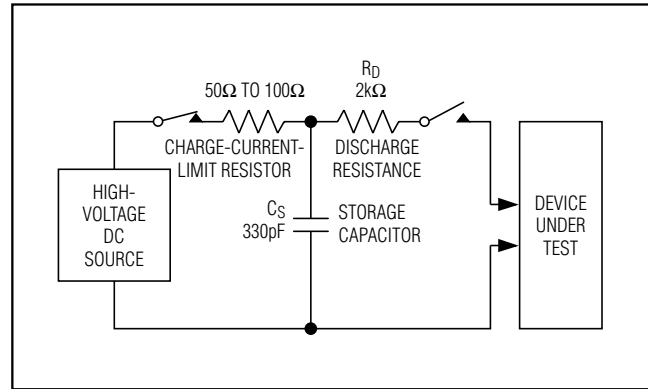

Figure 15. ISO 10605 Contact-Discharge ESD Test Circuit

### Chip Information

TRANSISTOR COUNT: 16,608

PROCESS: CMOS

# 27-Bit, 3MHz-to-35MHz DC-Balanced LVDS Serializer

## Package Information

(The package drawing(s) in this data sheet may not reflect the most current specifications. For the latest package outline information, go to [www.maxim-ic.com/packages](http://www.maxim-ic.com/packages).)

MAX9217

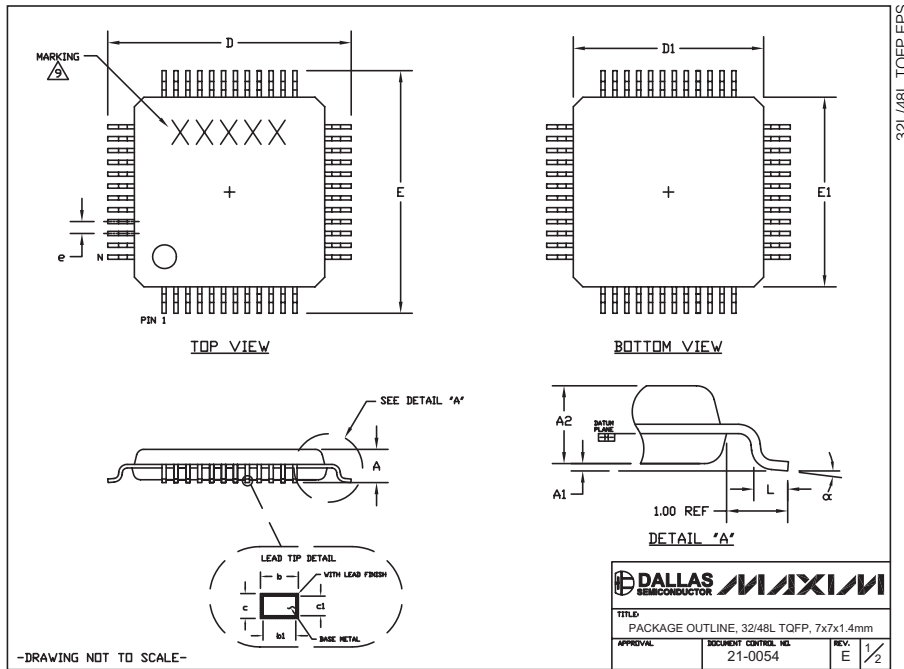

### NOTES:

1. ALL DIMENSIONING AND TOLERANCING CONFORM TO ANSI Y14.5-1982.
2. DATUM PLANE FEE IS LOCATED AT MOLD PARTING LINE AND COINCIDENT WITH LEAD, WHERE LEAD EXITS PLASTIC BODY AT BOTTOM OF PARTING LINE.
3. DIMENSIONS D1 AND E1 DO NOT INCLUDE MOLD PROTRUSION. ALLOWABLE MOLD PROTRUSION IS 0.25 MM ON D1 AND E1 DIMENSIONS.
4. THE TOP OF PACKAGE IS SMALLER THAN THE BOTTOM OF PACKAGE BY 0.15 MILLIMETERS.
5. DIMENSION b DOES NOT INCLUDE DAMBAR PROTRUSION. ALLOWABLE DAMBAR PROTRUSION SHALL BE 0.08 MM TOTAL IN EXCESS OF THE b DIMENSION AT MAXIMUM MATERIAL CONDITION.
6. ALL DIMENSIONS ARE IN MILLIMETERS.
7. THIS OUTLINE CONFORMS TO JEDEC PUBLICATION 95, REGISTRATION MS-026.
8. LEADS SHALL BE COPLANAR WITHIN .004 INCH.
9. MARKING SHOWN IS FOR PACKAGE ORIENTATION REFERENCE ONLY.
10. NUMBER OF LEADS ARE SHOWN FOR REFERENCE ONLY.

	JEDEC VARIATION			
	BBA		BBC	
	MIN.	MAX.	MIN.	MAX.
A	--	1.60	--	1.60
A1	0.05	0.15	0.05	0.15
A2	1.35	1.45	1.35	1.45
D	8.90	9.10	8.90	9.10
D1	6.90	7.10	6.90	7.10
E	8.90	9.10	8.90	9.10
E1	6.90	7.10	6.90	7.10
e	0.8	BSC.	0.5	BSC.
L	0.45	0.75	0.45	0.75
b	0.30	0.45	0.17	0.27
bl	0.30	0.40	0.17	0.23
c	0.09	0.20	0.09	0.20
cl	0.09	0.16	0.09	0.16
N	32		48	
alpha	0°	7°	0°	7°

-DRAWING NOT TO SCALE-

**DALLAS SEMICONDUCTOR** **MAXIM**

TITLE: PACKAGE OUTLINE, 32/48L TQFP, 7x7x1.4mm

APPROVAL:	DOCUMENT CONTROL NO. 21-0054	REV. E 2/2
-----------	------------------------------	------------

# 27-Bit, 3MHz-to-35MHz DC-Balanced LVDS Serializer

## Package Information (continued)

(The package drawing(s) in this data sheet may not reflect the most current specifications. For the latest package outline information, go to [www.maxim-ic.com/packages](http://www.maxim-ic.com/packages).)

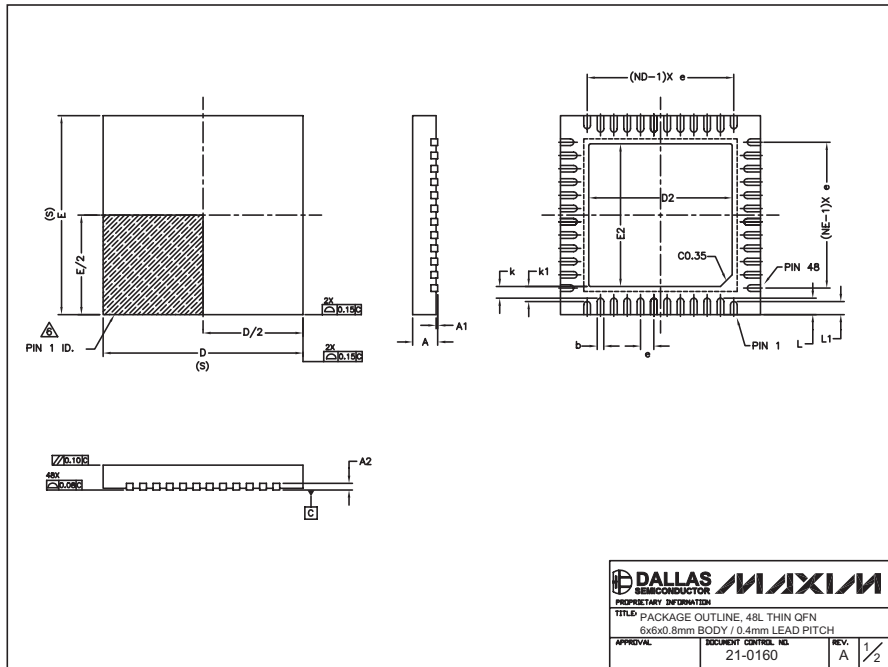

**NOTE :**

1. ALL DIMENSIONS ARE IN mm. ANGLES IN DEGREES.
2. COPLANARITY APPLIES TO THE EXPOSED PAD AS WELL AS THE TERMINALS. COPLANARITY SHALL NOT EXCEED 0.08mm.
3. WARPAGE SHALL NOT EXCEED 0.10 mm.
4. PACKAGE LENGTH / PACKAGE WIDTH ARE CONSIDERED AS SPECIAL CHARACTERISTIC. (S)
5. REFER TO JEDEC MO-220.
- △ THE TERMINAL #1 IDENTIFIER AND TERMINAL NUMBERING CONVENTION SHALL CONFORM TO JESD 95-1 SPP-012. DETAILS OF TERMINAL #1 IDENTIFIER ARE OPTIONAL, BUT MUST BE LOCATED WITHIN THE ZONE INDICATED. THE TERMINAL #1 IDENTIFIER MAY BE EITHER A MOLD OR MARKED FEATURE.
7. ND AND NE REFER TO THE NUMBER OF TERMINALS ON EACH D AND E SIDE RESPECTIVELY.

COMMON DIMENSIONS			
SYMBOLS	MIN.	NOM.	MAX.
A	0.700	0.750	0.800
A1	0.000	--	0.050
A2	0.200 REF.		
b	0.150	0.200	0.250
D	5.900	6.000	6.100
e	0.400 TYP.		
E	5.900	6.000	6.050
k	0.250	0.350	0.450
k1	0.350	0.450	0.550
L	0.400	0.500	0.600
L1	0.300	0.400	0.500
N	48		
ND	12		
NE	12		

PKG. CODE	D2			E2		
	MIN.	NOM.	MAX.	MIN.	NOM.	MAX.
T4866-1	4.20	4.30	4.40	4.20	4.30	4.40

<b>DALLAS SEMICONDUCTOR</b>		<b>MAXIM</b>	
PROPRIETARY INFORMATION			
TITLE: PACKAGE OUTLINE, 48L THIN QFN 6x6x0.8mm BODY / 0.4mm LEAD PITCH			
APPROVAL:	DOCUMENT CONTROL, NO.	REV.	
	21-0160	A	2/2

Maxim cannot assume responsibility for use of any circuitry other than circuitry entirely embodied in a Maxim product. No circuit patent licenses are implied. Maxim reserves the right to change the circuitry and specifications without notice at any time.