

DATA SHEET

MAX809/MAX810

3-pin microprocessor resets

Product data
Supersedes data of 2002 Oct 21

2003 Aug 08

3-pin microprocessor resets

MAX809/MAX810

DESCRIPTION

The MAX809/MAX810 are single function microprocessor resets used to monitor supply voltages in microprocessor and other logic systems. They provide a reset signal to the microprocessor during power-up, power-down, and brownout conditions. The reset signal is asserted when the supply voltage drops below the preset threshold, and the signal is released a set time after the supply voltage has risen above the preset threshold.

The MAX809 has an active-LOW reset output while the MAX810 has an active-HIGH reset output.

The low supply current of typically 17 μA makes the MAX809/MAX810 ideal for use in portable, battery operated equipment. They are available in the 3-pin SOT23 and SC70 packages.

FEATURES

- Monitors 5.0 V, 3.3 V and 3 V supplies
- 140 ms min. reset delay time:
 - Active-LOW RESET output (MAX809)
 - Active-HIGH RESET output (MAX810)
- Power supply transient immunity
- Guaranteed reset valid for 1.1 V
- Available in small SOT23 and SC70 3-pin packages
- No external components needed
- Specified over full temperature range $-40\text{ }^{\circ}\text{C}$ to $+105\text{ }^{\circ}\text{C}$

APPLICATIONS

- Embedded controllers
- Battery operated systems
- Wireless communication systems
- PDAs and handheld equipment

SIMPLIFIED SYSTEM DIAGRAMS

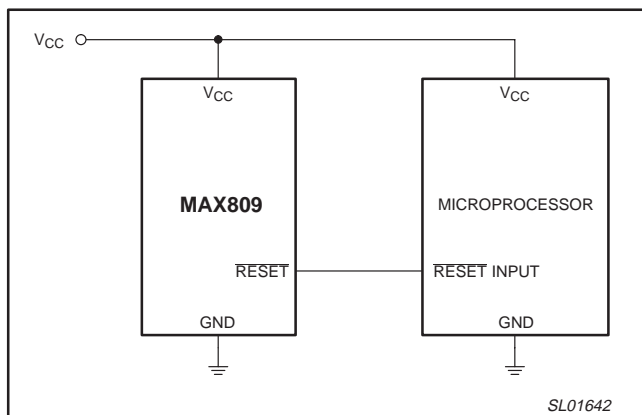

Figure 1. MAX809 simplified system diagram.

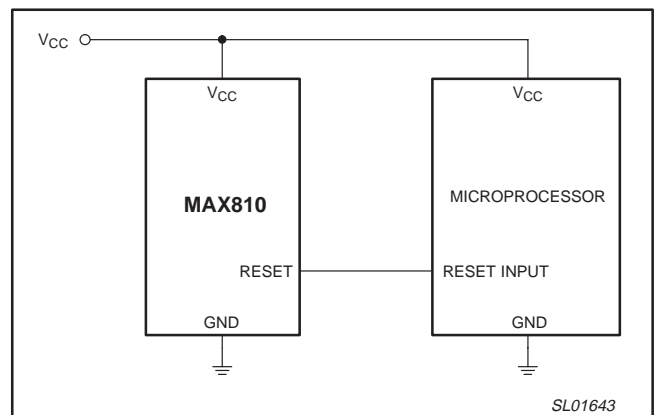

Figure 2. MAX810 simplified system diagram.

3-pin microprocessor resets

MAX809/MAX810

ORDERING INFORMATION

TYPE NUMBER	PACKAGE		TEMPERATURE RANGE
	NAME	DESCRIPTION	
MAX809xD	SOT23-3	plastic small outline package; 3 leads (see dimensional drawing)	-40 to +105 °C
MAX810xD	SOT23-3	plastic small outline package; 3 leads (see dimensional drawing)	-40 to +105 °C
MAX809xW	SC70-3	plastic small outline package; 3 leads; body width 1.15 mm	-40 to +105 °C
MAX810xW	SC70-3	plastic small outline package; 3 leads; body width 1.15 mm	-40 to +105 °C

NOTE:

Each device has 7 voltage options, indicated by the 'x' on the 'Type number'.

Part number	Reset Threshold Voltage (Typical)	Part number	Reset Threshold Voltage (Typical)
MAX809		MAX810	
MAX809ZD, MAX809ZW	2.32 V	MAX810ZD, MAX810ZW	2.32 V
MAX809RD, MAX809RW	2.63 V	MAX810RD, MAX810RW	2.63 V
MAX809SD, MAX809SW	2.93 V	MAX810SD, MAX810SW	2.93 V
MAX809TD, MAX809TW	3.08 V	MAX810TD, MAX810TW	3.08 V
MAX809JD, MAX809JW	4.00 V	MAX810JD, MAX810JW	4.00 V
MAX809MD, MAX809MW	4.38 V	MAX810MD, MAX810MW	4.38 V
MAX809LD, MAX809LW	4.63 V	MAX810LD, MAX810LW	4.63 V

Marking code

Each device is marked with a four letter code. The first three letters designate the product. The fourth, represented by an 'x', designates the date tracking code.

Part	Marking	Part	Marking
MAX809		MAX810	
MAX809JD	AMUx	MAX810LD	ANTx
MAX809LD	AMVx	MAX810RD	ANUx
MAX809MD	AMWx	MAX810SD	ANVx
MAX809RD, W	AMXx	MAX810JD	ANWx
MAX809SD	AMYx	MAX810MD	ANXx
MAX809TD	AMZx	MAX810TD	ANYx
MAX809ZD	AMAx	MAX810ZD	ANZx

3-pin microprocessor resets

MAX809/MAX810

PINNING

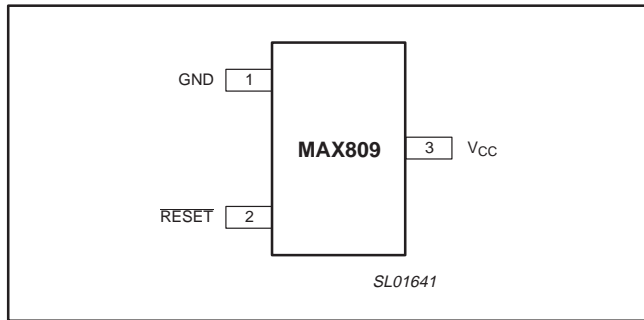

Figure 3. MAX809 pin configuration.

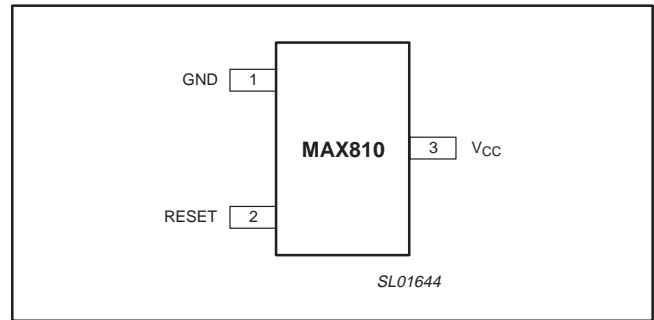

Figure 4. MAX810 pin configuration.

MAX809 pin description

PIN	SYMBOL	DESCRIPTION
1	GND	Device ground.
2	$\overline{\text{RESET}}$	Active-LOW reset signal.
3	V _{CC}	Supply voltage input.

MAX810 pin description

PIN	SYMBOL	DESCRIPTION
1	GND	Device ground.
2	RESET	Active-HIGH reset signal.
3	V _{CC}	Supply voltage input.

MAXIMUM RATINGS

SYMBOL	PARAMETER	CONDITIONS	MIN.	MAX.	UNIT
V _{CC}	Supply voltage		-0.3	6.0	V
V _i ($\overline{\text{RESET}}$)	Input voltage at RESET pin (MAX809)		-0.3	V _{CC} + 0.3	V
V _i (RESET)	Input voltage at RESET pin (MAX810)		-0.3	V _{CC} + 0.3	V
I _i (V _{CC})	Input current at V _{CC} pin		-	20	mA
I _o	Output current		-	20	mA
	Rate of rise at V _{CC}		-	100	V/ μ s
T _{amb}	Ambient temperature		-40	+105	°C
T _{stg}	Storage temperature		-65	+150	°C
P	Power dissipation	Derate 4 mW/°C above T _{amb} = 70 °C	-	320	mW

3-pin microprocessor resets

MAX809/MAX810

ELECTRICAL CHARACTERISTICS

V_{CC} = full range ($T_{amb} = -40\text{ °C}$ to $+105\text{ °C}$) unless otherwise noted; typical values are at $T_{amb} = +25\text{ °C}$, and $V_{CC} = 5\text{ V}$ (J/L/M versions), $V_{CC} = 3.3\text{ V}$ (T/S versions), $V_{CC} = 3\text{ V}$ (R version), and $V_{CC} = 2.5\text{ V}$ (Z version) (Note 1).

SYMBOL	PARAMETER	CONDITIONS		MIN.	TYP.	MAX.	UNIT		
	V_{CC} range	$T_{amb} = 0\text{ °C}$ to $+70\text{ °C}$		1.0	–	5.5	V		
		$T_{amb} = -40\text{ °C}$ to $+105\text{ °C}$		1.2	–	5.5	V		
I_{CC}	Supply current (SOT23-3)	MAX809J/L/M MAX810J/L/M	$V_{CC} < 5.5\text{ V}$; $T_{amb} = -40\text{ °C}$ to $+85\text{ °C}$	–	24	60	μA		
		MAX809R/S/T/Z MAX810R/S/T/Z	$V_{CC} < 3.6\text{ V}$; $T_{amb} = -40\text{ °C}$ to $+85\text{ °C}$	–	17	50	μA		
		MAX809J/L/M MAX810J/L/M	$V_{CC} < 5.5\text{ V}$; $T_{amb} = +85\text{ °C}$ to $+105\text{ °C}$	–	–	100	μA		
		MAX809R/S/T/Z MAX810R/S/T/Z	$V_{CC} < 3.6\text{ V}$; $T_{amb} = +85\text{ °C}$ to $+105\text{ °C}$	–	–	100	μA		
I_{CC}	Supply current (SC70-3)	MAX809J/L/M MAX810J/L/M	$V_{CC} < 5.5\text{ V}$; $T_{amb} = -40\text{ °C}$ to $+85\text{ °C}$	–	24	35	μA		
		MAX809R/S/T/Z MAX810R/S/T/Z	$V_{CC} < 3.6\text{ V}$; $T_{amb} = -40\text{ °C}$ to $+85\text{ °C}$	–	17	30	μA		
		MAX809J/L/M MAX810J/L/M	$V_{CC} < 5.5\text{ V}$; $T_{amb} = +85\text{ °C}$ to $+105\text{ °C}$	–	–	60	μA		
		MAX809R/S/T/Z MAX810R/S/T/Z	$V_{CC} < 3.6\text{ V}$; $T_{amb} = +85\text{ °C}$ to $+105\text{ °C}$	–	–	60	μA		
V_{th}	RESET threshold voltage (SOT23-3 and SC70-3)	MAX809Z MAX810Z	$T_{amb} = +25\text{ °C}$	2.28	2.32	2.35	V		
			$T_{amb} = -40\text{ °C}$ to $+85\text{ °C}$	2.25	–	2.38	V		
			$T_{amb} = +85\text{ °C}$ to $+105\text{ °C}$	2.22	–	2.42	V		
		MAX809R MAX810R	$T_{amb} = +25\text{ °C}$	2.59	2.63	2.66	V		
			$T_{amb} = -40\text{ °C}$ to $+85\text{ °C}$	2.55	–	2.70	V		
			$T_{amb} = +85\text{ °C}$ to $+105\text{ °C}$	2.50	–	2.76	V		
		MAX809S MAX810S	$T_{amb} = +25\text{ °C}$	2.89	2.93	2.96	V		
			$T_{amb} = -40\text{ °C}$ to $+85\text{ °C}$	2.85	–	3.00	V		
			$T_{amb} = +85\text{ °C}$ to $+105\text{ °C}$	2.78	–	3.08	V		
		MAX809T MAX810T	$T_{amb} = +25\text{ °C}$	3.04	3.08	3.11	V		
			$T_{amb} = -40\text{ °C}$ to $+85\text{ °C}$	3.00	–	3.15	V		
			$T_{amb} = +85\text{ °C}$ to $+105\text{ °C}$	2.92	–	3.23	V		
		MAX809J MAX810J	$T_{amb} = +25\text{ °C}$	3.93	4.00	4.06	V		
			$T_{amb} = -40\text{ °C}$ to $+85\text{ °C}$	3.89	–	4.10	V		
			$T_{amb} = +85\text{ °C}$ to $+105\text{ °C}$	3.80	–	4.20	V		
		MAX809M MAX810M	$T_{amb} = +25\text{ °C}$	4.31	4.38	4.45	V		
			$T_{amb} = -40\text{ °C}$ to $+85\text{ °C}$	4.25	–	4.50	V		
			$T_{amb} = +85\text{ °C}$ to $+105\text{ °C}$	4.16	–	4.56	V		
		MAX809L MAX810L	$T_{amb} = +25\text{ °C}$	4.56	4.63	4.70	V		
			$T_{amb} = -40\text{ °C}$ to $+85\text{ °C}$	4.50	–	4.75	V		
			$T_{amb} = +85\text{ °C}$ to $+105\text{ °C}$	4.40	–	4.86	V		
			Reset threshold temperature coefficient			–	30	–	ppm/°C
			V_{CC} to RESET delay	$V_{CC} = V_{th}$ to $(V_{th} - 100\text{ mV})$		–	20	–	μs
			RESET active time-out period (SOT23-3)	$T_{amb} = -40\text{ °C}$ to $+85\text{ °C}$		140	240	560	ms
$T_{amb} = +85\text{ °C}$ to $+105\text{ °C}$				100	–	840	ms		
	RESET active time-out period (SC70-3)	$T_{amb} = -40\text{ °C}$ to $+85\text{ °C}$		140	240	460	ms		
		$T_{amb} = +85\text{ °C}$ to $+105\text{ °C}$		100	–	840	ms		

3-pin microprocessor resets

MAX809/MAX810

SYMBOL	PARAMETER	CONDITIONS		MIN.	TYP.	MAX.	UNIT
$V_{OL(\overline{\text{RESET}})}$	LOW-level output voltage on RESET pin	MAX809R/S/T/Z	$V_{CC} > V_{th(\text{min})}$; $I_{\text{sink}} = 1.2 \text{ mA}$	–	–	0.3	V
		MAX809J/L/M	$V_{CC} > V_{th(\text{min})}$; $I_{\text{sink}} = 3.2 \text{ mA}$	–	–	0.4	V
		MAX809	$V_{CC} > 1.0 \text{ V}$; $I_{\text{sink}} = 50 \mu\text{A}$	–	–	0.3	V
$V_{OH(\overline{\text{RESET}})}$	HIGH-level output voltage on RESET pin	MAX809R/S/T/Z	$V_{CC} > V_{th(\text{max})}$; $I_{\text{source}} = 500 \mu\text{A}$	$0.8 \times V_{CC}$	–	–	V
		MAX809J/L/M	$V_{CC} > V_{th(\text{max})}$; $I_{\text{source}} = 800 \mu\text{A}$	$V_{CC} - 1.5$	–	–	V
$V_{OL(\overline{\text{RESET}})}$	LOW-level output voltage on RESET pin	MAX810R/S/T/Z	$V_{CC} > V_{th(\text{max})}$; $I_{\text{sink}} = 1.2 \text{ mA}$	–	–	0.3	V
		MAX810J/L/M	$V_{CC} > V_{th(\text{max})}$; $I_{\text{sink}} = 3.2 \text{ mA}$	–	–	0.4	V
$V_{OH(\overline{\text{RESET}})}$	HIGH-level output voltage on RESET pin	MAX810	$1.8 \text{ V} < V_{CC} > V_{th(\text{min})}$; $I_{\text{source}} = 150 \mu\text{A}$	$0.8 \times V_{CC}$	–	–	V

NOTES:

1. Production testing done at $T_{\text{amb}} = +25 \text{ }^\circ\text{C}$; limits over temperature guaranteed by design.
2. RESET output for MAX809; RESET output for MAX810.

3-pin microprocessor resets

MAX809/MAX810

APPLICATION INFORMATION

Detailed description

A microprocessor reset ensures that the microprocessor starts in a known and safe state. The reset asserts a reset signal to prevent code execution errors during power up, power down, or brownout conditions.

A reset must assert an output within a predictable range of the supply voltage. The common threshold voltage range is between 5% and 10% of the nominal supply voltage. MAX809/MAX810 have 4.63 V, 3.08 V and 2.63 V options for 5 V, 3.3 V and 3.0 V supplies respectively. They have high accuracy (within $\pm 3\%$) that ensures that the reset thresholds occur within the safe operating range. Whenever the supply voltage falls below the reset threshold, the reset signal is asserted. It remains asserted for at least 140 ms after the supply voltage rises above the threshold. At this point the reset is released. This delay time helps ensure valid reset signals despite erratic changes in supply voltage. The MAX809/MAX810 have a push-pull output stage and do not require a pull-up resistor.

Negative-going V_{CC} transients

The MAX809/MAX810 are relatively immune to short negative-going V_{CC} transients and glitches. Figure 5 shows the maximum pulse width a negative-going transient can have without causing a reset signal. As the magnitude of the transient increases below the reset threshold, the maximum allowable pulse width decreases. Typically, for the 4.0 V, 4.38 V, and 4.63 V versions of the MAX809/MAX810, a V_{CC} transient that goes 100 mV below the reset threshold and lasts 20 μ s or less will not cause a reset signal. To provide additional transient rejection, connect a 10 nF bypass capacitor as close as possible to the V_{CC} pin.

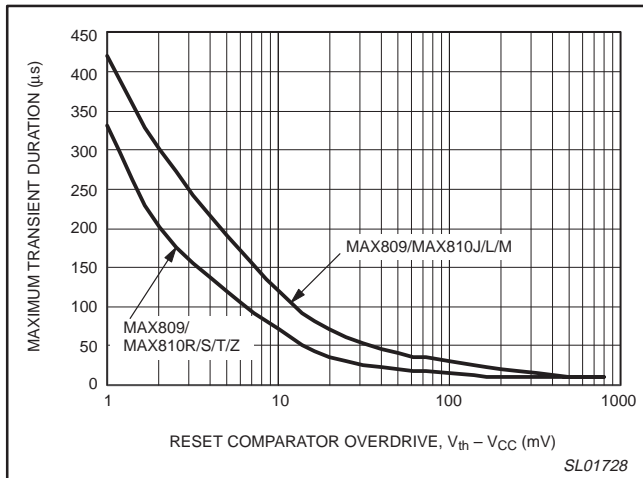

Figure 5. Maximum transient duration without causing a reset pulse versus reset comparator overdrive.

Ensuring a valid reset output down to $V_{CC} = 0$ V

When V_{CC} falls below 1 V, the MAX809 $\overline{\text{RESET}}$ no longer sinks current (i.e., it becomes open circuit). A high impedance CMOS logic input connected to $\overline{\text{RESET}}$ can drift to undetermined voltages. In most applications in which the microprocessor circuitry is inoperative below 1 V, this will not represent a problem. However, in applications in which $\overline{\text{RESET}}$ must be valid down to 0 V, use a

relatively large resistor from $\overline{\text{RESET}}$ to ground as shown in Figure 6. 100 k Ω is small enough to provide a path for any leakage currents to flow to ground (holding $\overline{\text{RESET}}$ LOW); while it is large enough not to load $\overline{\text{RESET}}$. Conversely, a 100 k Ω pull-up resistor is recommended for MAX810 if $\overline{\text{RESET}}$ is required to remain valid for $V_{CC} < 1$ V.

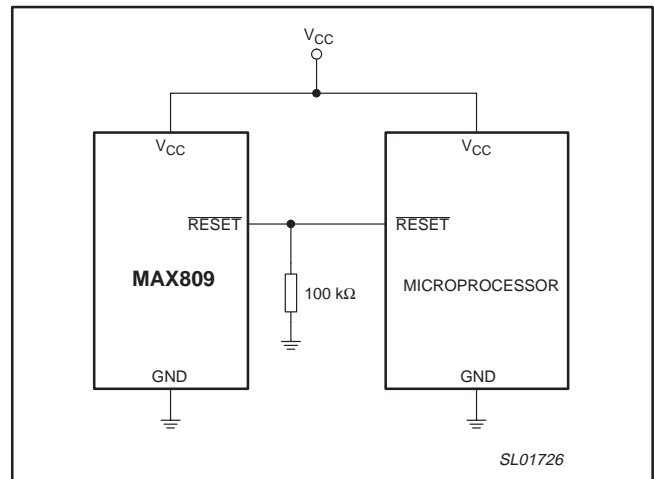

Figure 6. $\overline{\text{RESET}}$ valid to $V_{CC} = 0$ V circuit.

Interfacing to microprocessors with bi-directional reset pins

Microprocessors with bi-directional reset I/Os, such as the Motorola 68HC11 series, can be connected to the MAX809 $\overline{\text{RESET}}$ output. To ensure a correct output on the MAX809, even when the microprocessor reset I/O is in the opposite state, connect a 4.7 k Ω resistor between the reset pins as shown in Figure 7. This allows the microprocessor to issue commands to the system regardless of the state of the $\overline{\text{RESET}}$. The bi-directional microprocessor reset functions both as a driven reset input and as an active reset driver.

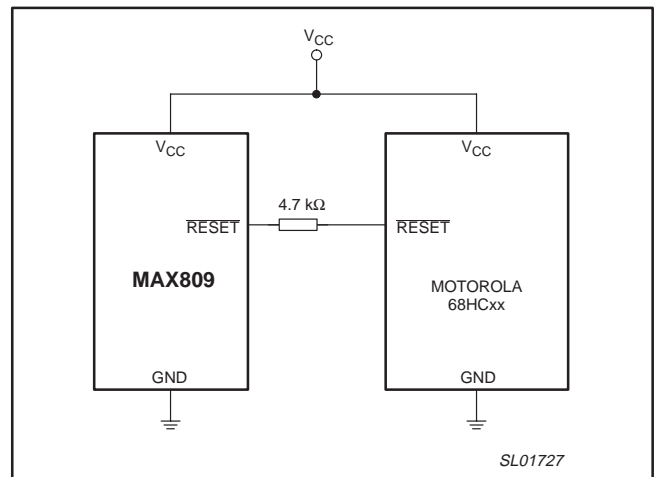

Figure 7. Interfacing to microprocessor with bi-directional reset I/O

3-pin microprocessor resets

MAX809/MAX810

PACKING METHOD

The MAX809 and MAX810 are packed in reels, as shown in Figure 8.

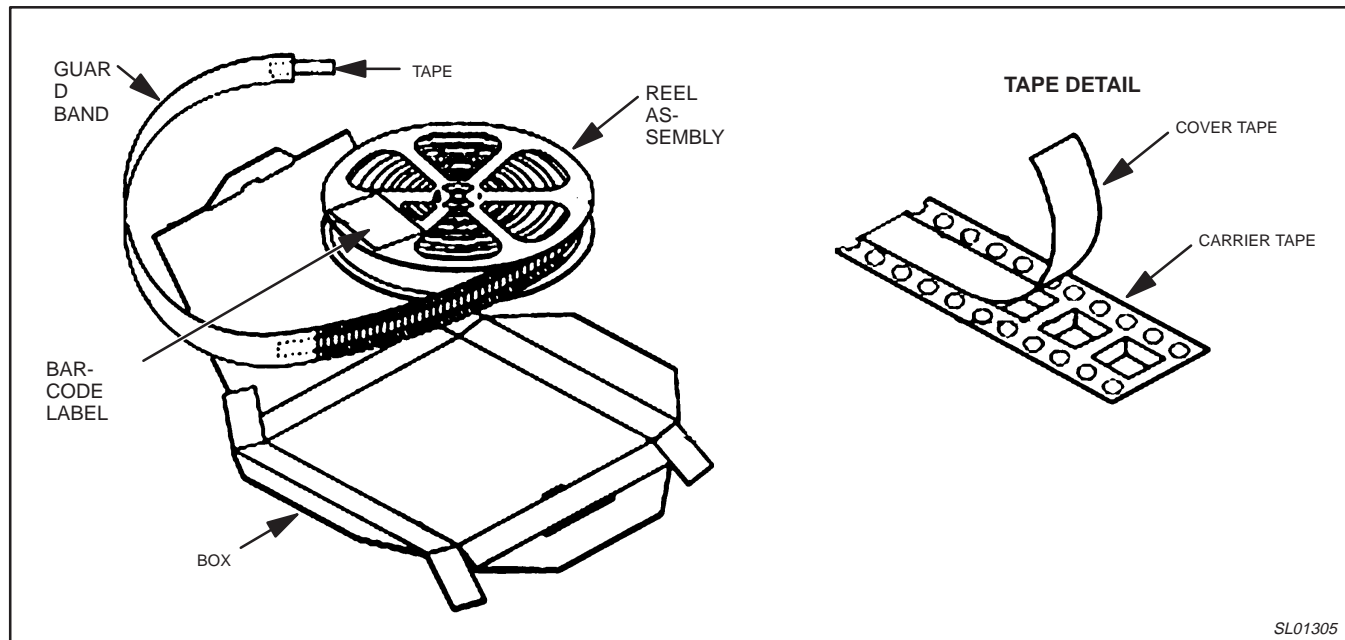
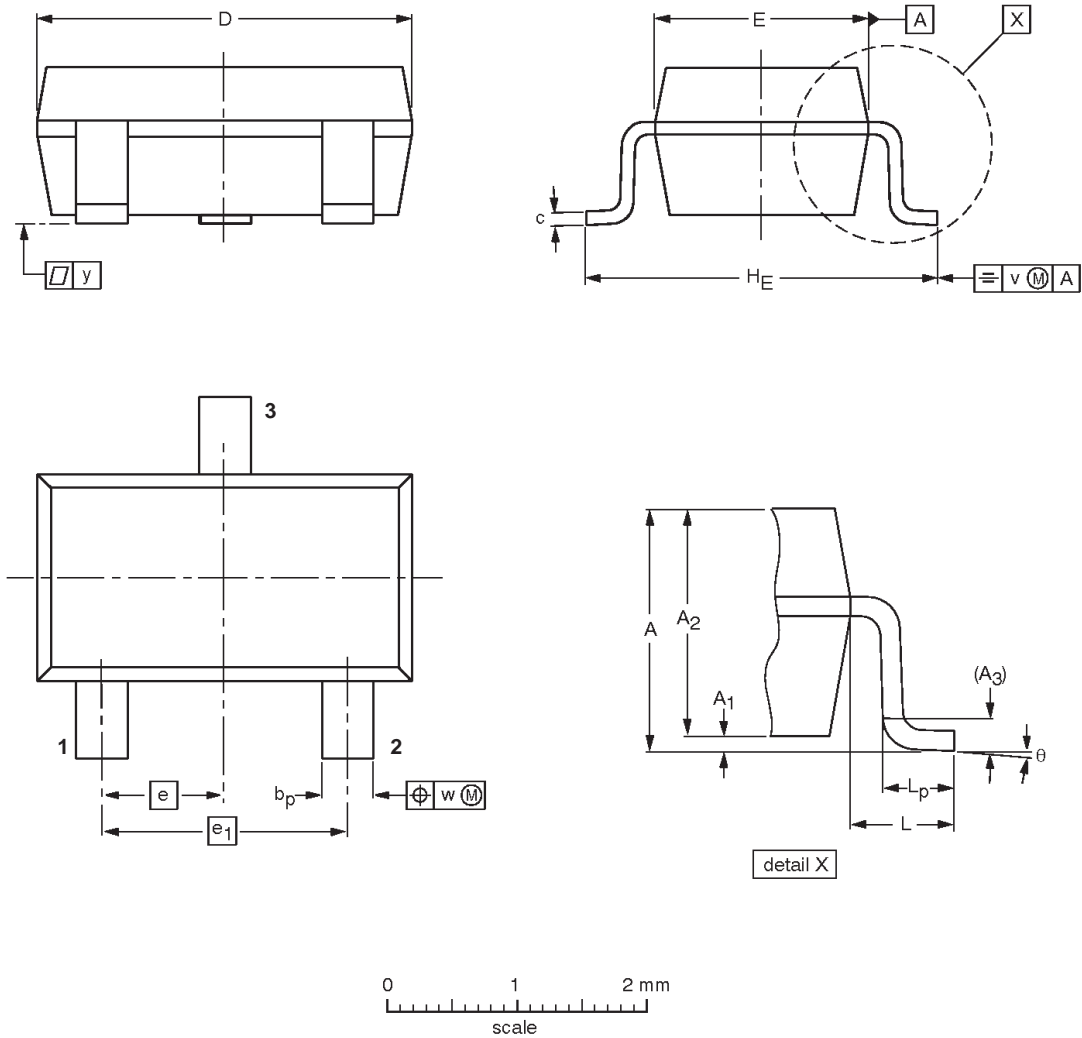

Figure 8. Tape and reel packing method.

3-pin microprocessor resets

MAX809/MAX810

SOT23-3: plastic small outline package; 3 leads; body width 1.5 mm



DIMENSIONS (mm are the original dimensions)

UNIT	A max.	A ₁	A ₂	A ₃	b _p	c	D ⁽¹⁾	E ⁽¹⁾	e	e ₁	H _E	L	L _p		y	θ
mm	1.35	0.15 0.05	1.2 1.0	0.25	0.50 0.25	0.22 0.08	3.00 2.70	1.70 1.50	0.95	1.90	3.00 2.60	0.60	0.55 0.35		0.1	10° 0°

Note

1. Plastic or metal protrusions of 0.25 mm maximum per side are not included.

3-pin microprocessor resets

MAX809/MAX810

SC70-3: plastic small outline package; 3 leads; body width 1.15 mm

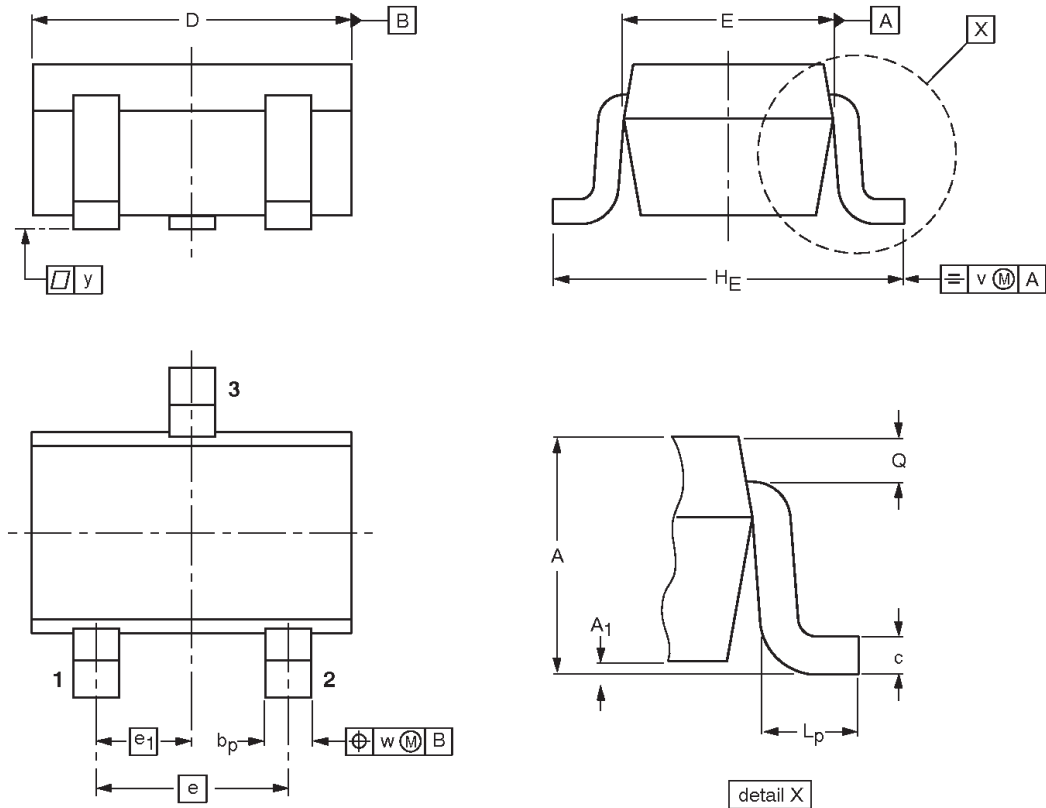

DIMENSIONS (mm are the original dimensions)

UNIT	A	A ₁ max	b _p	c	D	E	e	e ₁	H _E	L _p	Q	v	w
mm	1.0 0.8	0.1	0.4 0.25	0.225 0.10	2.1 1.9	1.35 1.15	1.3	0.65	2.2 2.0	0.45 0.15	0.4 0.1	0.2	0.2

OUTLINE VERSION	REFERENCES				EUROPEAN PROJECTION	ISSUE DATE
	IEC	JEDEC	EIAJ			
			SC-70			

3-pin microprocessor resets

MAX809/MAX810

REVISION HISTORY

Rev	Date	Description
_3	20030808	Product data (9397 750 11889); ECN 853–2355 30184 dated 04 August 2003. Supersedes MAX809_MAX810_2 of 2002 Oct 21 (9397 750 10584). Modifications: <ul style="list-style-type: none">• Add 'Marking code' table to Ordering information on page 3.• SOT23–3 package outline on page 9 corrected.
_2	20021021	Product data (9397 750 10584); ECN 853–2355 29047 dated 14 October 2002. Supersedes MAX809_MAX810_1 of 2002 June 20 (9397 750 10213).
_1	20020620	Product data (9397 750 10213); ECN 853–2355 28505 dated 20 June 2002.

3-pin microprocessor resets

MAX809/MAX810

Data sheet status

Level	Data sheet status ^[1]	Product status ^{[2] [3]}	Definitions
I	Objective data	Development	This data sheet contains data from the objective specification for product development. Philips Semiconductors reserves the right to change the specification in any manner without notice.
II	Preliminary data	Qualification	This data sheet contains data from the preliminary specification. Supplementary data will be published at a later date. Philips Semiconductors reserves the right to change the specification without notice, in order to improve the design and supply the best possible product.
III	Product data	Production	This data sheet contains data from the product specification. Philips Semiconductors reserves the right to make changes at any time in order to improve the design, manufacturing and supply. Relevant changes will be communicated via a Customer Product/Process Change Notification (CPCN).

[1] Please consult the most recently issued data sheet before initiating or completing a design.

[2] The product status of the device(s) described in this data sheet may have changed since this data sheet was published. The latest information is available on the Internet at URL <http://www.semiconductors.philips.com>.

[3] For data sheets describing multiple type numbers, the highest-level product status determines the data sheet status.

Definitions

Short-form specification — The data in a short-form specification is extracted from a full data sheet with the same type number and title. For detailed information see the relevant data sheet or data handbook.

Limiting values definition — Limiting values given are in accordance with the Absolute Maximum Rating System (IEC 60134). Stress above one or more of the limiting values may cause permanent damage to the device. These are stress ratings only and operation of the device at these or at any other conditions above those given in the Characteristics sections of the specification is not implied. Exposure to limiting values for extended periods may affect device reliability.

Application information — Applications that are described herein for any of these products are for illustrative purposes only. Philips Semiconductors make no representation or warranty that such applications will be suitable for the specified use without further testing or modification.

Disclaimers

Life support — These products are not designed for use in life support appliances, devices, or systems where malfunction of these products can reasonably be expected to result in personal injury. Philips Semiconductors customers using or selling these products for use in such applications do so at their own risk and agree to fully indemnify Philips Semiconductors for any damages resulting from such application.

Right to make changes — Philips Semiconductors reserves the right to make changes in the products—including circuits, standard cells, and/or software—described or contained herein in order to improve design and/or performance. When the product is in full production (status 'Production'), relevant changes will be communicated via a Customer Product/Process Change Notification (CPCN). Philips Semiconductors assumes no responsibility or liability for the use of any of these products, conveys no license or title under any patent, copyright, or mask work right to these products, and makes no representations or warranties that these products are free from patent, copyright, or mask work right infringement, unless otherwise specified.

Contact information

For additional information please visit
<http://www.semiconductors.philips.com>. Fax: +31 40 27 24825

© Koninklijke Philips Electronics N.V. 2003
 All rights reserved. Printed in U.S.A.

Date of release: 08-03

For sales offices addresses send e-mail to:
sales.addresses@www.semiconductors.philips.com

Document order number:

9397 750 11889

Let's make things better.