



Loss-of-Sync Alarm

MAX7461

General Description

The MAX7461 single-channel loss-of-sync alarm ($\overline{\text{LOS}}$) provides composite video sync detection in NTSC, PAL, and SECAM standard-definition television (SDTV) systems. The MAX7461's advanced detection circuitry delivers robust performance by preventing false loss-of-sync alarms due to noise. The device accepts an AC-coupled composite (CVBS), luma (Y), or any other video signal with sync, and outputs a logic-level signal. The open-drain $\overline{\text{LOS}}$ output is low when no sync is detected and high impedance when sync is detected. The device operates from a single +5V supply.

The MAX7461 is available in a 5-pin SOT23 package and is specified for operation over the -40°C to +85°C temperature range.

Features

- ◆ Accepts CVBS, Y, or Any Other Video with Sync
- ◆ Loss-of-Sync Alarm Output
- ◆ Robust Performance in Noisy Environments
- ◆ Wire-OR Alarm Output
- ◆ NTSC, PAL, and SECAM
- ◆ Small 5-Pin SOT23 Package

Ordering Information

PART	TEMP RANGE	PIN-PACKAGE	PACKAGE CODE
MAX7461EUK	-40°C to +85°C	5 SOT23-5	U5-2

Applications

- Security Systems
- Automotive Rear Seat Entertainment (RSE) Systems
- Consumer Electronics

Pin Configuration

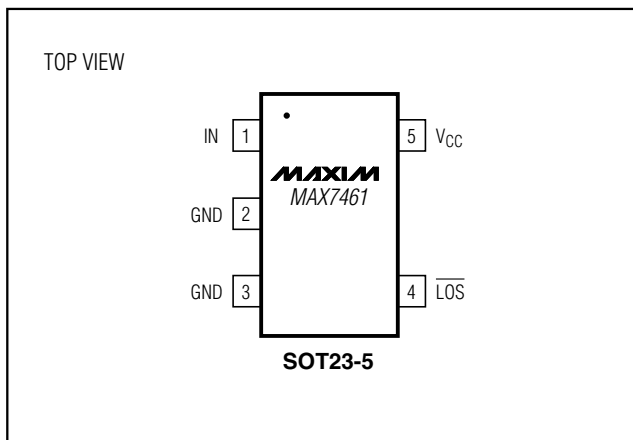

Functional Diagram

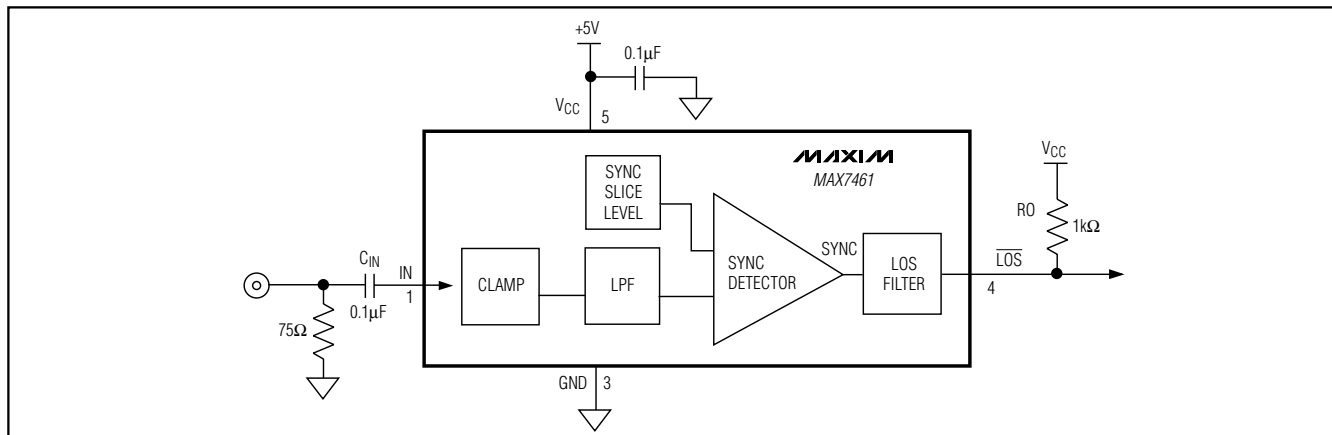

Loss-of-Sync Alarm

ABSOLUTE MAXIMUM RATINGS

V _{CC} to GND	-0.3V to +6V
LOS to GND	-0.3V to +6V
IN to GND	-0.3V to the lower of +6V and (V _{CC} + 0.3V)
Continuous Power Dissipation (T _A = +70°C)	
5-Pin SOT23-5 (derate 7.1mW/°C above +70°C)	571.0mW
Maximum Current Into Any Pin	±50mA

Operating Temperature Range	
MAX7461EUK	-40°C to +85°C
Storage Temperature Range	-65°C to +150°C
Lead Temperature (soldering, 10s)	+300°C
Junction Temperature	+150°C

Stresses beyond those listed under "Absolute Maximum Ratings" may cause permanent damage to the device. These are stress ratings only, and functional operation of the device at these or any other conditions beyond those indicated in the operational sections of the specifications is not implied. Exposure to absolute maximum rating conditions for extended periods may affect device reliability.

ELECTRICAL CHARACTERISTICS

(V_{CC} = +4.5V to +5.5V, GND = 0, C_{IN} = 0.1μF, R_O = 500Ω, T_A = -40°C to +85°C, unless otherwise noted. Typical values are at T_A = +25°C.)

PARAMETER	SYMBOL	CONDITIONS	MIN	TYP	MAX	UNITS
AC CHARACTERISTICS						
Minimum Input Sync Height	V _{IN-MIN}	AC-coupled (Note 1)		105	130	mV _{P-P}
Maximum Input Voltage	V _{IN-MAX}	AC-coupled	2.4			V _{P-P}
LOS Release Time	t _{RT}	(Note 2)	1.7	2.2	2.7	ms
LOS Detect Time	t _{DT}	(Note 3)	1.9	3.4	4.9	
DIGITAL CHARACTERISTICS						
Output Low Voltage	V _{OL}	I _{SINK} = 10mA			0.4	V
Logic High Leakage Current	I _{OLEAK}				1	μA
POWER REQUIREMENTS						
Supply Voltage	V _{CC}		4.5	5.0	5.5	V
Supply Current	I _{CC}			1.7	2.2	mA
Power-Supply Noise Immunity	V _{PSNI}	0 to 5MHz sinusoid on V _{CC} (Note 4)		200		mV _{P-P}

Note 1: Minimum input sync height is the voltage above which $\overline{\text{LOS}}$ is guaranteed to be in high-impedance mode after the maximum LOS time-constant time.

Note 2: LOS release time is the time that the video input must be continuously present before $\overline{\text{LOS}}$ goes high (inactive state).

Note 3: The LOS detect time is the time that the video input must be continuously absent before $\overline{\text{LOS}}$ goes low (active state).

Note 4: The MAX7461 $\overline{\text{LOS}}$ output is accurate with a power-supply noise level below V_{PSNI}.

Loss-of-Sync Alarm

MAX7461

Typical Operating Characteristics

($V_{CC} = 5V$, $GND = 0$, $C_{IN} = 0.1\mu F$, $R_O = 10k\Omega$, $T_A = +25^\circ C$, unless otherwise noted.)

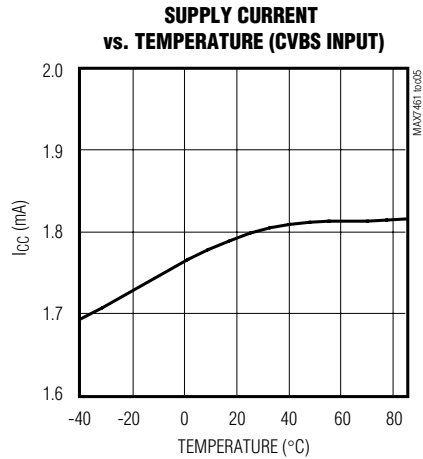
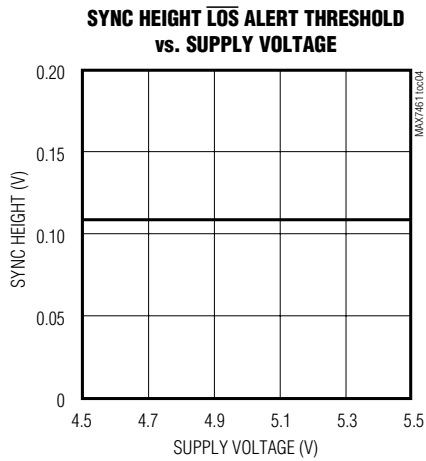
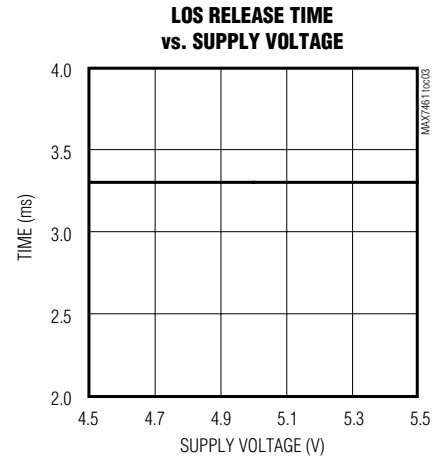
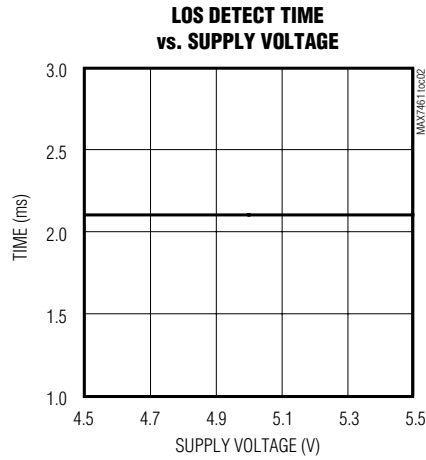
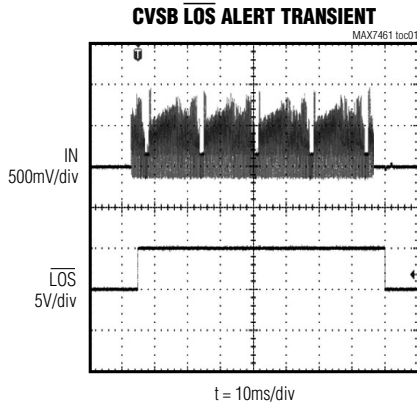

Loss-of-Sync Alarm

Pin Description

PIN	NAME	FUNCTION
1	IN	Video Input. Accepts CVBS, luma (Y), or any video input with sync. AC-couple IN with a series 0.1µF capacitor.
2, 3	GND	Ground
4	$\overline{\text{LOS}}$	Loss-Of-Sync Output (Open Drain). $\overline{\text{LOS}}$ is in high impedance when sync pulses are detected, and is pulled low when no horizontal sync signal is detected for more than the LOS detect time. $\overline{\text{LOS}}$ returns high when sync pulses are detected for more than the LOS release time. Connect a 1kΩ pullup resistor from $\overline{\text{LOS}}$ to VCC.
5	VCC	Power-Supply Input. Bypass to GND with a 0.1µF capacitor.

Detailed Description

The MAX7461 single-channel LOS alarm is ideal for any video system needing to verify the presence of a video source. The device accepts an AC-coupled CVBS, Y, or any video signal with sync, and pulls $\overline{\text{LOS}}$ low when no composite sync signal is detected for more than the LOS detect time (3.4ms, typ) at the input (IN).

Clamp

The MAX7461 features an input clamp that corrects any DC shift, on a line-by-line basis. The external AC-coupling capacitor provides DC isolation for the input.

Lowpass Filter

The MAX7461 integrates a lowpass filter for enhanced sync detection. The lowpass filter prevents false sync detection by reducing color burst, chroma, and noise.

Sync Detector/LOS Filter

The sync detector looks for sync pulses greater than the minimum sync voltage (0.13V_{P-P}). If the detector does not detect any sync pulses for 3.4ms (typ), the LOS filter pulls $\overline{\text{LOS}}$ low. After detecting sync for at least 2.2ms (typ), the LOS filter returns $\overline{\text{LOS}}$ to a high-impedance state. $\overline{\text{LOS}}$ is an open-drain output. Connect a 1kΩ pullup resistor between $\overline{\text{LOS}}$ and VCC.

Power-On Reset (POR)

At power-up, $\overline{\text{LOS}}$ is pulled low and the MAX7461 checks for 2.2ms (typ) of valid sync pulses before releasing $\overline{\text{LOS}}$. $\overline{\text{LOS}}$ remains high impedance while a valid sync signal is detected at the input.

Applications Information

Input Considerations

Use 0.1µF ceramic capacitors to AC-couple the input. The input cannot be DC-coupled. The input capacitor stores a DC level so that the video signal is clamped to an appropriate DC voltage for proper sync detection.

Power-Supply Bypassing

Careful PC board layout is important for optimal system performance. Do not use wire-wrapped boards or breadboards. When possible, use a multilayer board with a dedicated low-inductance ground plane and supply plane. Connect all GND inputs to a single ground plane and VCC to a single-supply plane. Bypass VCC to GND with a 0.1µF capacitor.

Wired-OR Application

The $\overline{\text{LOS}}$ open-drain output allows the MAX7461 to be used in wired-OR applications as shown in the automotive RSE typical application diagram of Figure 1.

Chip Information

PROCESS: BiCMOS

Loss-of-Sync Alarm

MAX7461

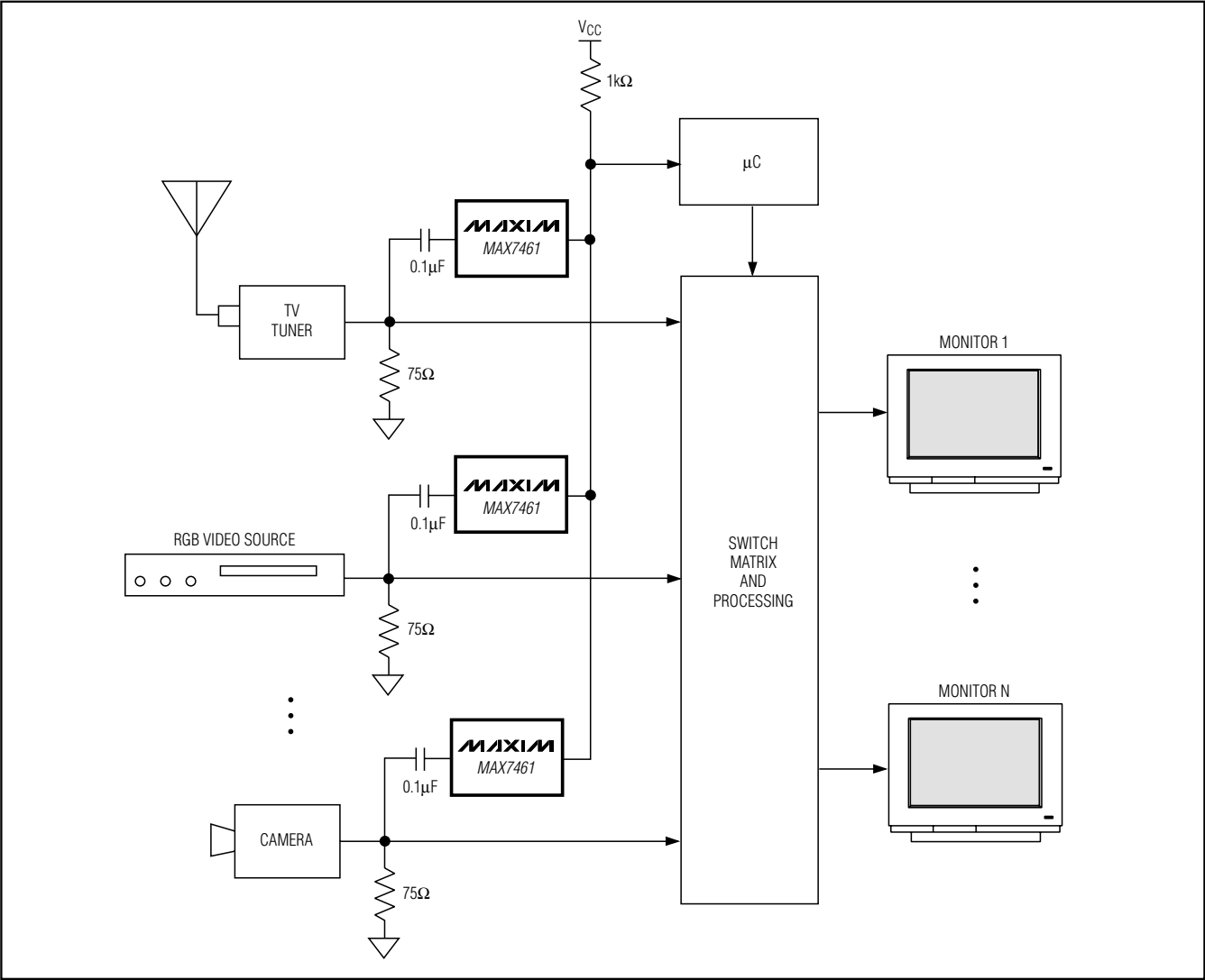

Figure 1. Automotive RSE System

Loss-of-Sync Alarm

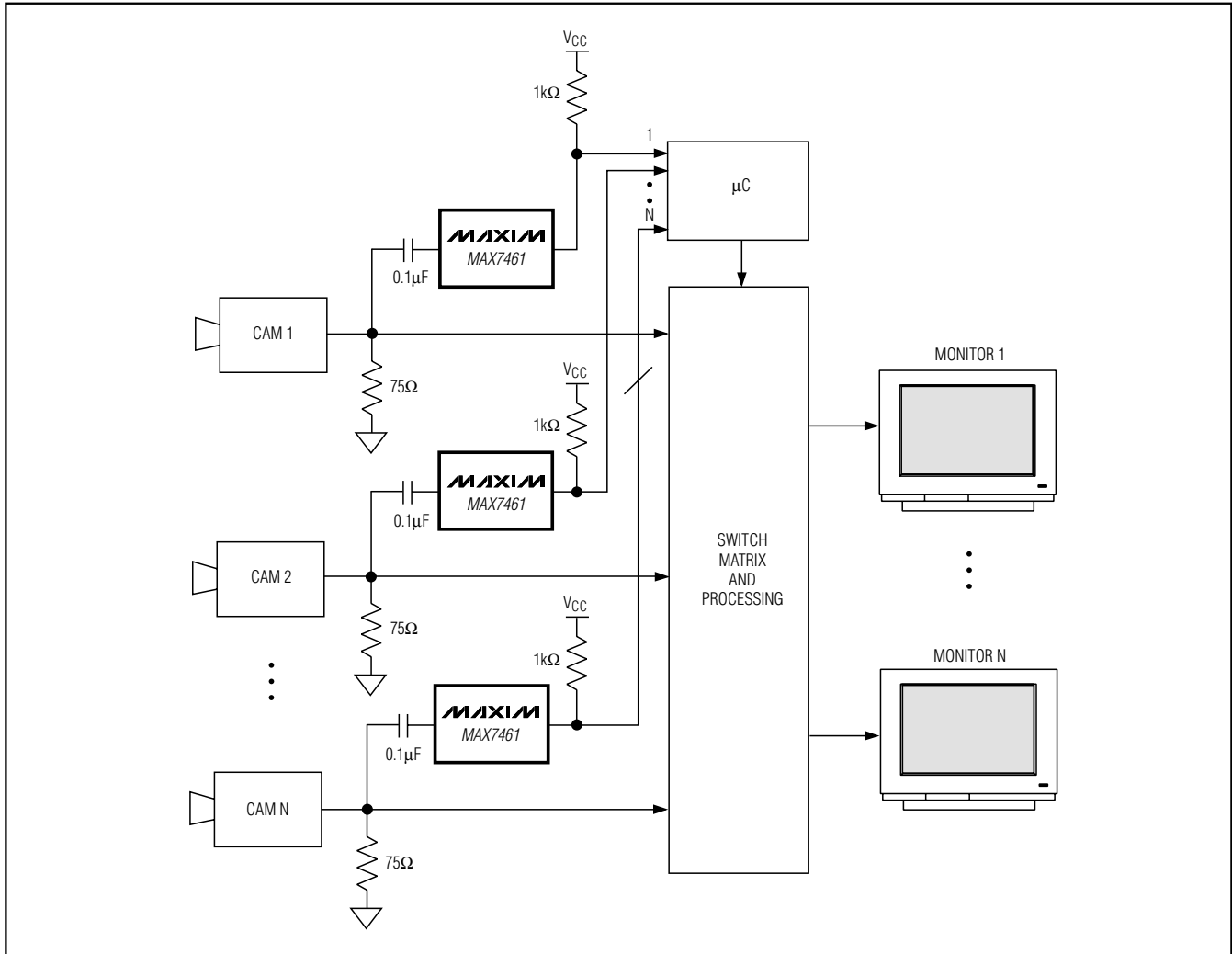

Figure 2. Video Security System

Loss-of-Sync Alarm

Package Information

(The package drawing(s) in this data sheet may not reflect the most current specifications. For the latest package outline information, go to www.maxim-ic.com/packages.)

MAX7461

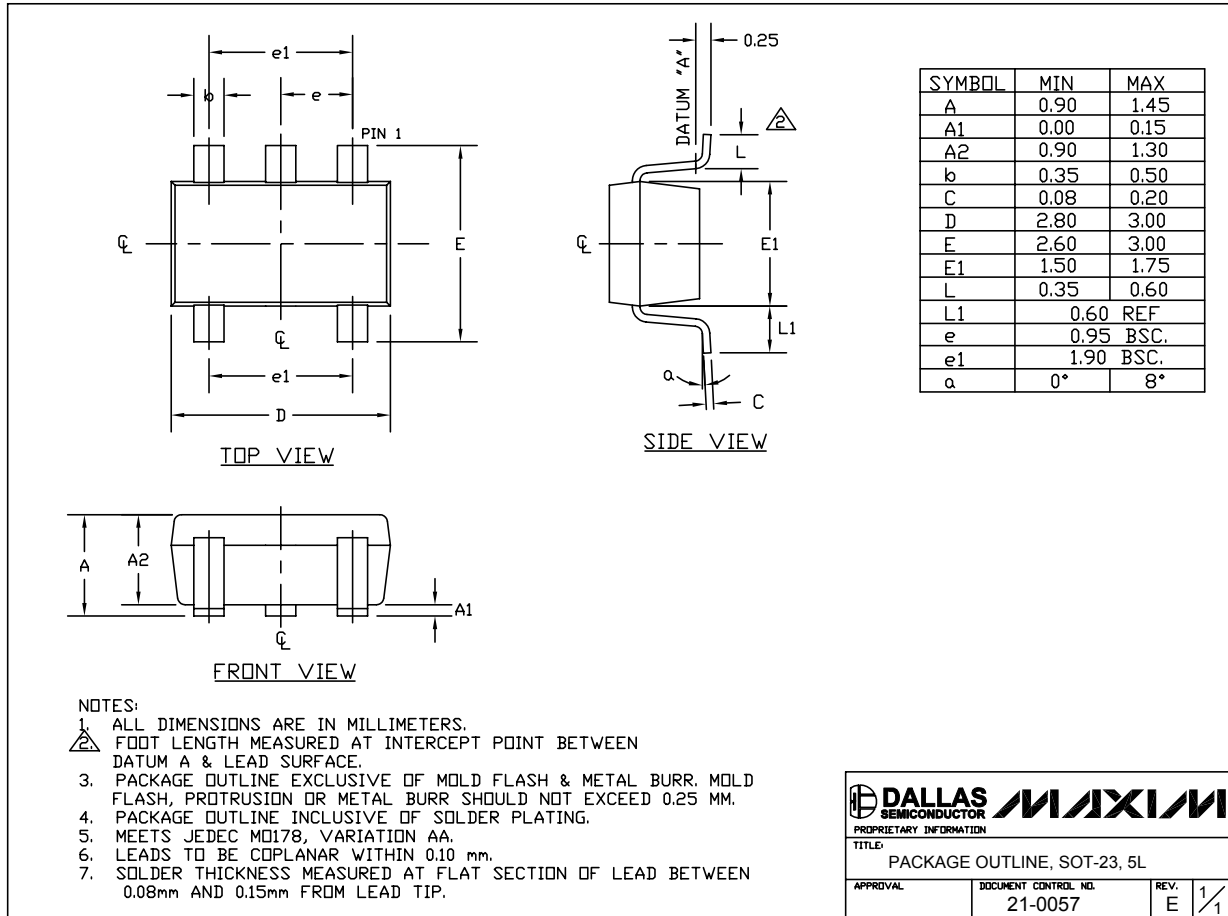

SOT-23 5L EPS

DALLAS SEMICONDUCTOR **MAXIM**
 PROPRIETARY INFORMATION
 TITLE: PACKAGE OUTLINE, SOT-23, 5L
 APPROVAL: _____ DOCUMENT CONTROL NO. 21-0057 REV. E 1/1

Maxim cannot assume responsibility for use of any circuitry other than circuitry entirely embodied in a Maxim product. No circuit patent licenses are implied. Maxim reserves the right to change the circuitry and specifications without notice at any time.

Maxim Integrated Products, 120 San Gabriel Drive, Sunnyvale, CA 94086 408-737-7600 _____ **7**