



# 4-Wire Interfaced, 2.7V to 5.5V, 4-Digit 5 × 7 Matrix LED Display Driver

MAX6952

## General Description

The MAX6952 is a compact cathode-row display driver that interfaces microprocessors to 5 × 7 dot-matrix LED displays through an SPI™-compatible serial interface. The MAX6952 drives up to four digits (140 LEDs).

Included on chip are an ASCII 104-character font, multiplex scan circuitry, column and row drivers, and static RAM that stores each digit, as well as font data for 24 user-definable characters. The segment current for the LEDs is set by an internal digit-by-digit digital brightness control.

The device includes a low-power shutdown mode, segment blinking (synchronized across multiple drivers, if desired), and a test mode that forces all LEDs on. The LED drivers are slew rate limited to reduce EMI.

For a 2-wire interfaced version, refer to the MAX6953 data sheet. An EV kit is available for the MAX6952.

## Applications

- |                     |                       |
|---------------------|-----------------------|
| Message Boards      | Audio/Video Equipment |
| Medical Equipment   | Gaming Machines       |
| Industrial Displays |                       |

## Features

- ◆ High-Speed 26MHz with SPI-/QSPI™-/MICROWIRE™-Compatible Serial Interface
- ◆ 2.7V to 5.5V Operation
- ◆ Drives Four Monocolor or Two Bicolor Cathode-Row 5 × 7 Matrix Displays
- ◆ Built-In ASCII 104-Character Font
- ◆ 24 User-Definable Characters Available
- ◆ Automatic Blinking Control for Each Segment
- ◆ 36µA Low-Power Shutdown (Data Retained)
- ◆ 16-Step Digital Brightness Control
- ◆ Display Blanked on Power-Up
- ◆ Slew-Rate-Limited Segment Drivers for Lower EMI
- ◆ 36-Pin SSOP and 40-Pin DIP Packages

## Ordering Information

PART	TEMP RANGE	PIN-PACKAGE
MAX6952EAX	-40°C to +85°C	36 SSOP
MAX6952EPL	-40°C to +85°C	40 PDIP

Pin Configurations appear at end of data sheet.

SPI and QSPI are trademarks of Motorola, Inc.  
MICROWIRE is a trademark of National Semiconductor Corp.

## Typical Application Circuit

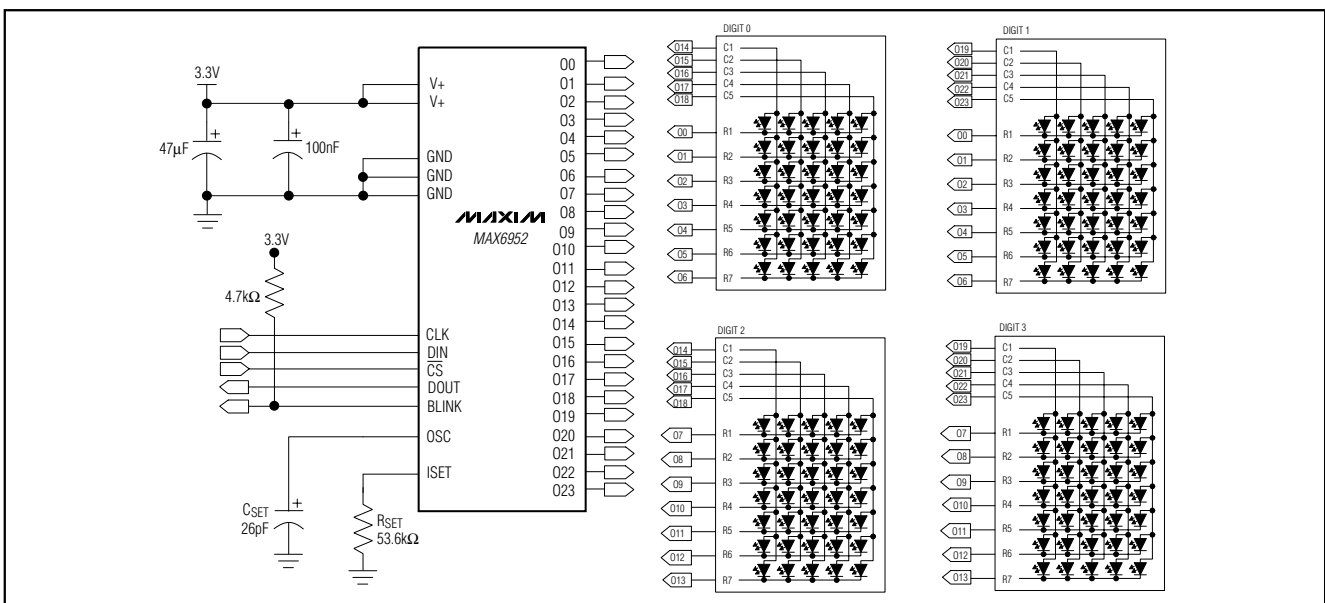

# 4-Wire Interfaced, 2.7V to 5.5V, 4-Digit 5 × 7 Matrix LED Display Driver

## ABSOLUTE MAXIMUM RATINGS

Voltage (with respect to GND)	
V+ .....	-0.3V to +6V
All Other Pins .....	-0.3V to (V+ + 0.3V)
O0–O13 Sink Current .....	500mA
O14–O23 Source Current .....	50mA
Continuous Power Dissipation (T <sub>A</sub> = +70°C)	
36-Pin SSOP (derate 11.8mW/°C above +70°C) .....	941.2mW
40-Pin PDIP (derate 16.7mW/°C above +70°C) .....	1333mW

Operating Temperature Range (T <sub>MIN</sub> , T <sub>MAX</sub> ) .....	-40°C to +85°C
Junction Temperature .....	+150°C
Storage Temperature Range .....	-65°C to +150°C
Lead Temperature (soldering, 10s) .....	+300°C

Stresses beyond those listed under "Absolute Maximum Ratings" may cause permanent damage to the device. These are stress ratings only, and functional operation of the device at these or any other conditions beyond those indicated in the operational sections of the specifications is not implied. Exposure to absolute maximum rating conditions for extended periods may affect device reliability.

## DC ELECTRICAL CHARACTERISTICS

(Typical operating circuit, V+ = 3.0V to 5.5V, T<sub>A</sub> = T<sub>MIN</sub> to T<sub>MAX</sub>, unless otherwise noted.) (Note 1)

PARAMETER	SYMBOL	CONDITIONS	MIN	TYP	MAX	UNITS
Operating Supply Voltage	V+		2.7		5.5	V
Shutdown Supply Current	I <sub>SHDN</sub>	Shutdown mode, all digital inputs at V+ or GND	T <sub>A</sub> = T <sub>MIN</sub> to T <sub>MAX</sub>		100	μA
			T <sub>A</sub> = +25°C		36	80
Operating Supply Current	I+	All segments on, intensity set to full, internal oscillator, DOOUT open circuit, no display load connected, blink open circuit		12	16	mA
Master Clock Frequency (OSC Internal Oscillator)	f <sub>OSC</sub>	OSC = RC oscillator, R <sub>SET</sub> = 53.6kΩ, C <sub>SET</sub> = 26pF		4		MHz
Master Clock Frequency (OSC External Oscillator)	f <sub>OSC</sub>	OSC overdriven externally	1		8	MHz
Dead Clock Protection Frequency	f <sub>OSC</sub>			90		kHz
OSC Internal/External Detection Threshold	V <sub>OSC</sub>			1.7		V
OSC High Time	t <sub>CH</sub>		50			ns
OSC Low Time	t <sub>CL</sub>		50			ns
Slow Segment Blink Period (OSC Internal Oscillator)	f <sub>SLOWBLINK</sub>	OSC = RC oscillator, R <sub>SET</sub> = 53.6kΩ, C <sub>SET</sub> = 26pF		1		s
Fast Segment Blink Period (OSC Internal Oscillator)	f <sub>FASTBLINK</sub>	OSC = RC oscillator, R <sub>SET</sub> = 53.6kΩ, C <sub>SET</sub> = 26pF		0.5		s
Fast or Slow Segment Duty Cycle		(Note 2)	49.5		50.5	%
Column Drive Source Current	I <sub>COLUMN</sub>	V <sub>LED</sub> = 2.4V, V+ = 3.0V, T <sub>A</sub> = +25°C	-32		-48	mA
Segment Current Slew Rate	ΔI <sub>SEG</sub> /Δt	T <sub>A</sub> = +25°C		12.5		mA/μs
Segment Drive Current Matching (Within IC)	ΔI <sub>SEG</sub>	T <sub>A</sub> = +25°C		4		%

# 4-Wire Interfaced, 2.7V to 5.5V, 4-Digit 5 × 7 Matrix LED Display Driver

**MAX6952**

## DC ELECTRICAL CHARACTERISTICS (continued)

(Typical operating circuit, V+ = 3.0V to 5.5V, T<sub>A</sub> = T<sub>MIN</sub> to T<sub>MAX</sub>, unless otherwise noted.) (Note 1)

PARAMETER	SYMBOL	CONDITIONS	MIN	TYP	MAX	UNITS
<b>LOGIC INPUTS AND OUTPUTS</b>						
Input High Voltage DIN, CLK, $\overline{CS}$	V <sub>IH</sub>		2.4			V
Input Low Voltage DIN, CLK, $\overline{CS}$	V <sub>IL</sub>				0.4	V
Input Leakage DIN, CLK, $\overline{CS}$ , OSC	I <sub>IH</sub> , I <sub>IL</sub>		-2	+0.1	+2	μA
DOUT Output Low Voltage	V <sub>OLDO</sub>	I <sub>SINK</sub> = 1.6mA			0.4	V
DOUT Output High Voltage	V <sub>OHDO</sub>	I <sub>SOURCE</sub> = 1.6mA	V+ - 0.4V			V
Blink Output Low Voltage	V <sub>OLBK</sub>	I <sub>SINK</sub> = 1.6mA			0.4	V
<b>TIMING CHARACTERISTICS</b> (Figure 1)						
CLK Clock Period	t <sub>CP</sub>		38.4			ns
CLK Pulse Width High	t <sub>CH</sub>		19			ns
CLK Pulse Width Low	t <sub>CL</sub>		19			ns
$\overline{CS}$ Fall to CLK Rise Setup Time	t <sub>CSS</sub>		9.5			ns
CLK Rise to $\overline{CS}$ Rise Hold Time	t <sub>CSH</sub>		5			ns
DIN Setup Time	t <sub>DS</sub>		9.5			ns
DIN Hold Time	t <sub>DH</sub>		0			ns
$\overline{CS}$ Pulse High	t <sub>Csw</sub>		19			ns
DOUT Propagation Delay	t <sub>DO</sub>	C <sub>LOAD</sub> = 10pF			19	ns

**Note 1:** All parameters tested at T<sub>A</sub> = +25°C. Specifications over temperature are guaranteed by design.

**Note 2:** Guaranteed by design.

# 4-Wire Interfaced, 2.7V to 5.5V, 4-Digit 5 × 7 Matrix LED Display Driver

## Typical Operating Characteristics

(Typical application circuit, V+ = 3.3V, LED forward voltage = 2.4V, scan limit set to 4 digits, T<sub>A</sub> = +25°C, unless otherwise noted.)

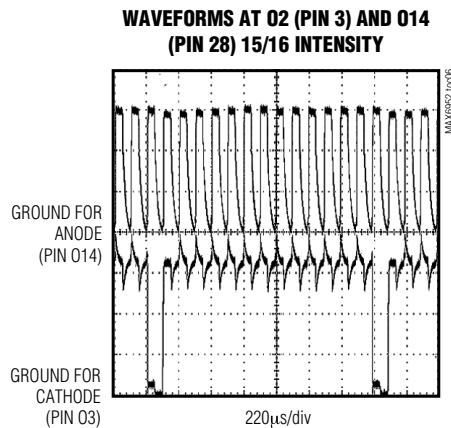
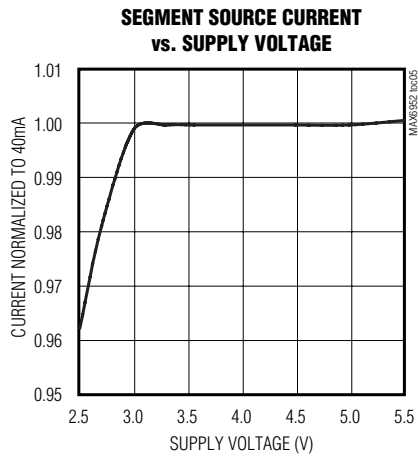
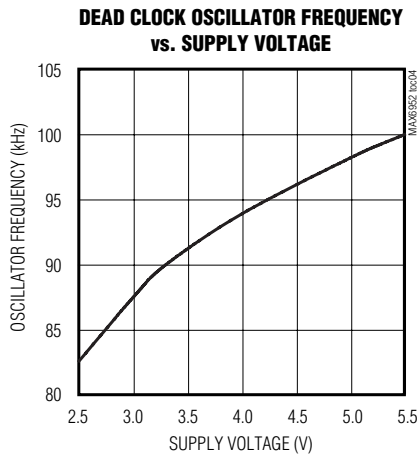
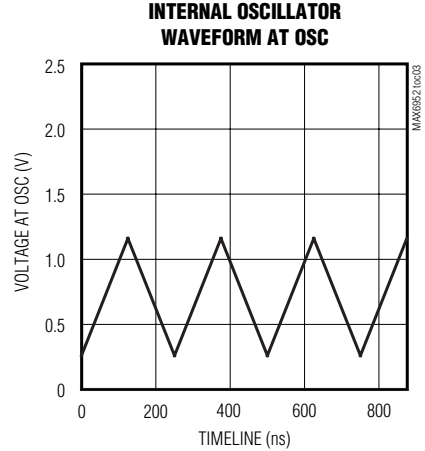
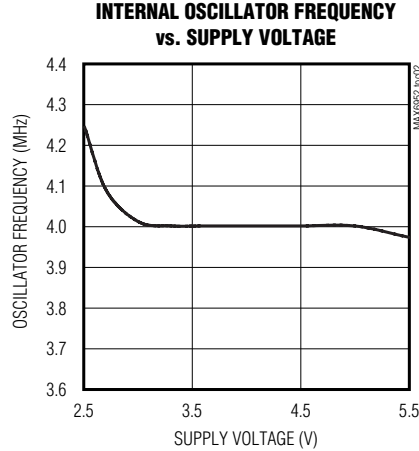
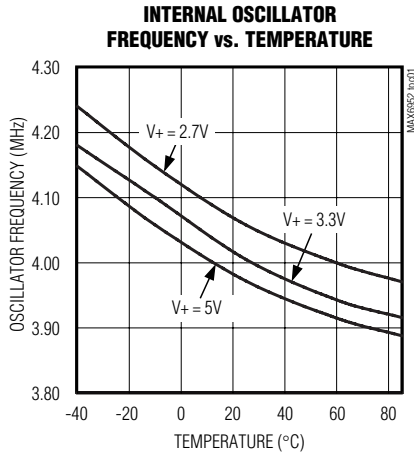

# 4-Wire Interfaced, 2.7V to 5.5V, 4-Digit 5 × 7 Matrix LED Display Driver

## Pin Description

MAX6952

PIN		NAME	FUNCTION
SSOP	PDIP		
1, 2, 3, 6–14, 23, 24	1, 2, 3, 7–15, 26, 27	O0 to O13	LED Cathode Drivers. O0 to O13 outputs sink current from the display's cathode rows.
4, 5, 16	4, 5, 6, 18	GND	Ground
15	17	ISET	Segment Current Setting. Connect ISET to GND through series resistor R <sub>SET</sub> to set the peak current.
17	19	BLINK	Blink Clock Output. Output is open drain.
18	20	DIN	Serial Data Input. Data is loaded into the internal 16-bit shift register on the rising edge of the CLK.
19	21	CLK	Serial-Clock Input. On the rising edge of CLK, data is shifted into the internal shift register. On the falling edge of CLK, data is clocked out of DOUT. CLK input is active only while CS is low.
20	22	DOUT	Serial Data Output. Data clocked into DIN is output to DOUT 15.5 clock cycles later. Data is clocked out on the rising edge of CLK. Output is push-pull.
21	23	$\overline{CS}$	Chip-Select Input. Serial data is loaded into the shift register while $\overline{CS}$ is low. The last 16 bits of serial data are latched on $\overline{CS}$ 's rising edge.
22	24	OSC	Multiplex Clock Input. To use the internal oscillator, connect capacitor C <sub>SET</sub> from OSC to GND. To use the external clock, drive OSC with a 1MHz to 8MHz CMOS clock.
25–31, 34, 35, 36	28–34, 38, 39, 40	O14 to O23	LED Anode Drivers. O14 to O23 outputs source current to the display's anode columns.
32, 33	35, 36, 37	V+	Positive Supply Voltage. Bypass V+ to GND with a 47μF bulk capacitor and a 0.1μF ceramic capacitor.

## Detailed Description

The MAX6952 is a serially interfaced display driver that can drive four digits of 5 × 7 cathode-row dot-matrix displays. The MAX6952 can drive either four monochrome digits (Table 1) or two bicolor digits (Table 2). The MAX6952 includes a 128-character font map comprising 104 predefined characters and 24 user-definable characters. The predefined characters follow the Arial font, with the addition of the following common symbols: £, €, ¥, °, μ, ±, ↑, and ↓. The 24 user-definable characters are uploaded by the user into on-chip RAM through the serial interface and are lost when the device is powered down. Figure 1 is the MAX6952 functional diagram.

## Serial Interface

The MAX6952 communicates through an SPI-compatible 4-wire serial interface. The interface has three inputs, clock (CLK), chip select ( $\overline{CS}$ ), and data in (DIN), and one output, data out (DOUT).  $\overline{CS}$  must be low to clock data into or out of the device, and DIN must be stable when sampled on the rising edge of CLK. DOUT is stable on the rising edge of CLK. Note that while the SPI protocol expects DOUT to be high impedance when the MAX6952 is not being accessed, DOUT on the MAX6952 is never high impedance.

# 4-Wire Interfaced, 2.7V to 5.5V, 4-Digit 5 × 7 Matrix LED Display Driver

**Table 1. Connection Scheme for Four Monocolor Digits**

DIGIT	O0	O1	O2	O3	O4	O5	O6	O7	O8	O9	O10	O11	O12	O13	O14	O15	O16	O17	O18	O19	O20	O21	O22	O23
1	Digit 0 rows (cathodes) R1 to R7 Digit 1 rows (cathodes) R1 to R7							—							Digit 0 columns (anodes) C1 to C5					Digit 1 columns (anodes) C6 to C10				
2	—							Digit 2 rows (cathodes) R1 to R7 Digit 3 rows (cathodes) R1 to R7							Digit 2 columns (anodes) C1 to C5					Digit 3 columns (anodes) C6 to C10				

**Table 2. Connection Scheme for Two Bicolor Digits**

DIGIT	O0	O1	O2	O3	O4	O5	O6	O7	O8	O9	O10	O11	O12	O13	O14	O15	O16	O17	O18	O19	O20	O21	O22	O23
1	Digit 0 rows (cathodes) R1 to R14							—							Digit 0 columns (anodes) C1 to C10 - the 5 green anodes -      - the 5 red anodes -									
2	—							Digit 1 rows (cathodes) R1 to R14							Digit 1 columns (anodes) C1 to C10 - the 5 green anodes -      - the 5 red anodes -									

**Table 3. Serial-Data Format (16 Bits)**

D15	D14	D13	D12	D11	D10	D9	D8	D7	D6	D5	D4	D3	D2	D1	D0	
R/W	ADDRESS							DATA							LSB	

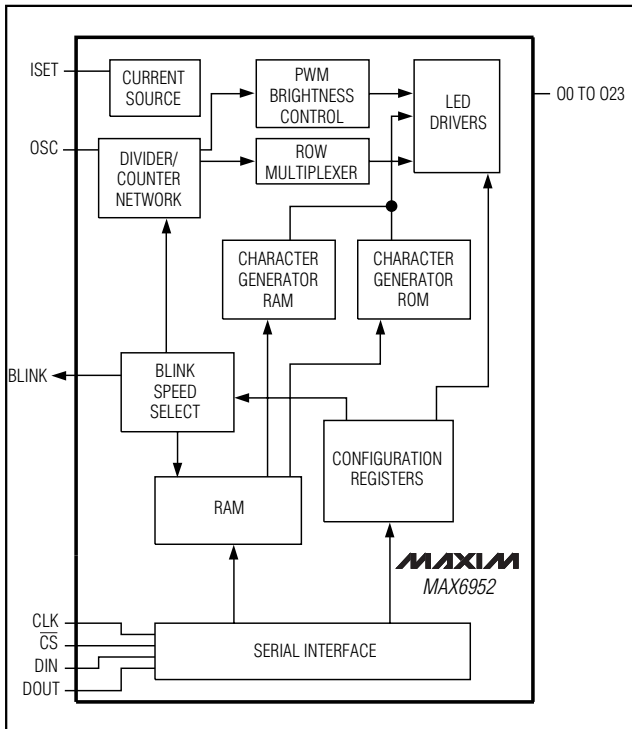

Figure 1. Functional Diagram

CLK and DIN may be used to transmit data to other peripherals. The MAX6952 ignores all activity on CLK and DIN except when  $\overline{CS}$  is low.

**Control and Operation Using the 4-Wire Interface**

Controlling the MAX6952 requires sending a 16-bit word. The first byte, D15 through D8, is the command byte (Table 3), and the second byte, D7 through D0, is the data byte.

**Connecting Multiple MAX6952s to the 4-Wire Bus**

Multiple MAX6952s may be daisy-chained by connecting the DOUT of one device to the DIN of the next, and driving CLK and  $\overline{CS}$  lines in parallel (Figure 6). Data at DIN propagates through the internal shift registers and appears at DOUT 15.5 clock cycles later, clocked out on the falling edge of CLK. When sending commands to daisy-chained MAX6952s, all devices are accessed at the same time. An access requires (16 x n) clock cycles, where n is the number of MAX6952s connected together. To update just one device in a daisy-chain, the user can send the no-op command (0x00) to the others.

**Writing Device Registers**

The MAX6952 contains a 16-bit shift register into which DIN data are clocked on the rising edge of SCLK, when  $\overline{CS}$  is low. When  $\overline{CS}$  is high, transitions on SCLK have no effect. When  $\overline{CS}$  goes high, the 16 bits in the shift

# 4-Wire Interfaced, 2.7V to 5.5V, 4-Digit 5 × 7 Matrix LED Display Driver

register are parallel loaded into a 16-bit latch. The 16 bits in the latch are then decoded and executed.

The MAX6952 is written to using the following sequence:

- 1) Take CLK low.
- 2) Take  $\overline{CS}$  low. This enables the internal 16-bit shift register.
- 3) Clock 16 bits of data into DIN, D15 first to D0 last, observing the setup and hold times. Bit D15 is low, indicating a write command.
- 4) Take  $\overline{CS}$  high (while CLK is still high after clocking in the last data bit).
- 5) Take CLK low.

Figure 3 shows a write operation when 16 bits are transmitted.

If fewer or greater than 16 bits are clocked into the MAX6952 between taking  $\overline{CS}$  low and taking  $\overline{CS}$  high again, the MAX6952 stores the last 16 bits received, including the previous transmission(s). The general case is when n bits (where  $n > 16$ ) are transmitted to the MAX6952. The last bits comprising bits {n-15} to {n} are retained and are parallel loaded into the 16-bit latch as bits D15 to D0, respectively (Figure 4).

## Reading Device Registers

Any register data within the MAX6952 may be read by sending a logic high to bit D15. The sequence is:

- 1) Take CLK low.
- 2) Take  $\overline{CS}$  low. This enables the internal 16-bit shift register.
- 3) Clock 16 bits of data into DIN, D15 first to D0 last, observing the setup and hold times. Bit D15 is high, indicating a read command and bits D14 through D8 contain the address of the register to read. Bits D7 to D0 contain dummy data, which is discarded.
- 4) Take  $\overline{CS}$  high. Positions D7 through D0 in the shift register are now loaded with the data in the register addressed by bits D15 through D8. Bits
- 5) Take CLK low.
- 6) Issue another read or write command (which can be a no-op), and examine the bit stream at DOUT; the second 8 bits are the contents of the register addressed by bits D14 through D8 in step 3.

## Digit Registers

The MAX6952 uses eight digit registers to store the characters that the user wishes to display on the four 5 × 7 LED digits. These digit registers are implemented with two planes of 4 bytes, called P0 and P1. Each LED digit

is represented by 2 bytes of memory, 1 byte in plane P0 and the other in plane P1. The digit registers are mapped so that a digit's data can be updated in plane P0, or plane P1, or both planes at the same time (Table 4).

If the blink function is disabled through the Blink Enable Bit E (Table 9) in the configuration register, then the digit register data in plane P0 is used to multiplex the display. The digit register data in P1 is not used. If the blink function is enabled, then the digit register data in both plane P0 and plane P1 are alternately used to multiplex the display. Blinking is achieved by multiplexing the LED display using data planes P0 and P1 on alternate phases of the blink clock (Table 10).

The data in the digit registers does not control the digit segments directly. Instead, the register data is used to address a character generator, which stores the data of a 128-character font (Table 14). The lower 7 bits of the digit data (D6 to D0) select the character from the font. The most-significant bit of the register data (D7) selects whether the font data is used directly (D7 = 0) or whether the font data is inverted (D7 = 1). The inversion feature can be used to enhance the appearance of bicolor displays by displaying, for example, a red character on a green background.

## Display Blink Mode

The display blinking facility, when enabled, makes the driver flip automatically between displaying the digit register data in planes P0 and P1. If the digit register data for any digit is different in the two planes, then that digit appears to flip between two characters. To make a character appear to blink on or off, write the character to one plane, and use the blank character (0x20) for the other plane. Once blinking has been configured, it continues automatically without further intervention.

## Blink Speed

The blink speed is determined by frequency of the multiplex clock, OSC, and by setting the Blink Rate Selection Bit B (Table 8) in the configuration register. The Blink Rate Selection Bit B sets either fast or slow blink speed for the whole display.

## Initial Power-Up

On initial power-up, all control registers are reset, the display is blanked, intensities are set to minimum, and shutdown is enabled (Table 5).

## Configuration Register

The configuration register is used to enter and exit shutdown, select the blink rate, globally enable and disable the blink function, globally clear the digit data, and reset the blink timing (Table 6).

# 4-Wire Interfaced, 2.7V to 5.5V, 4-Digit 5 × 7 Matrix LED Display Driver

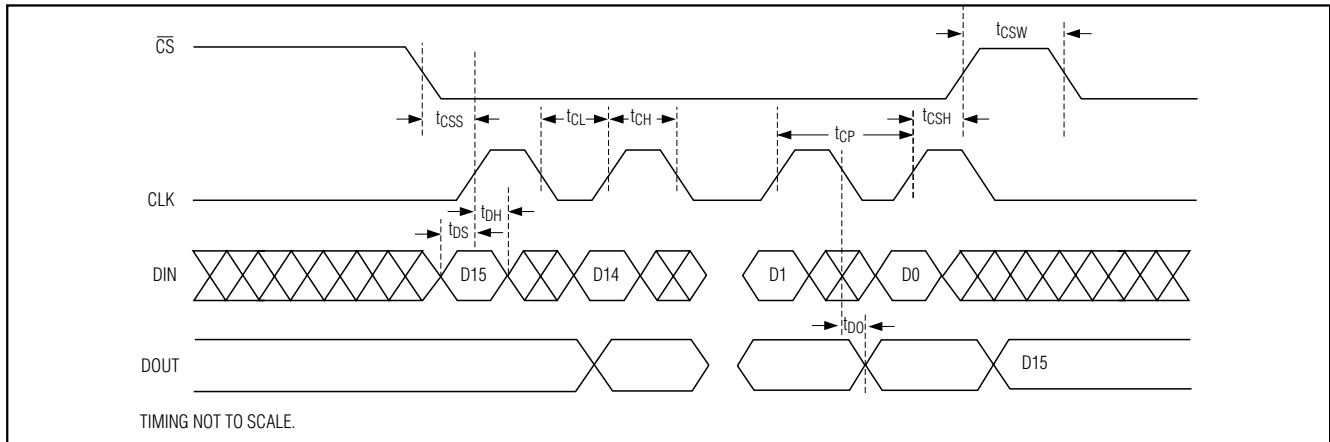

Figure 2. Timing Diagram

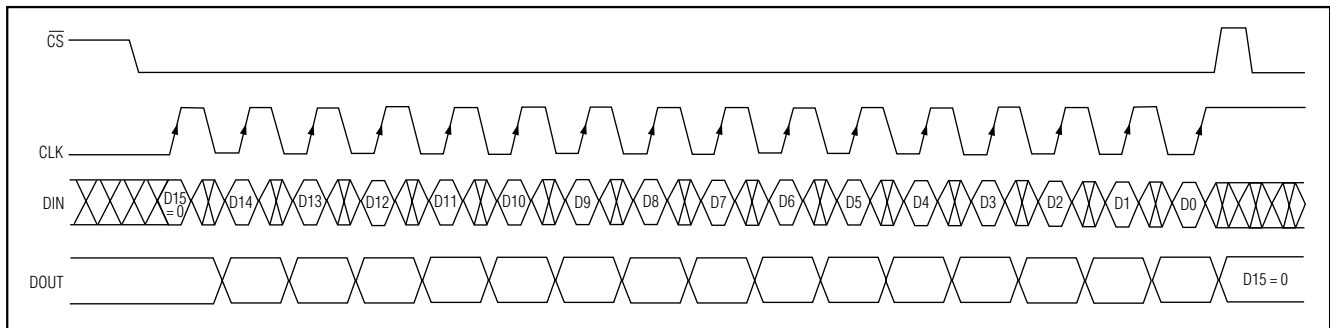

Figure 3. 16-Bit Write Transmission to the MAX6952

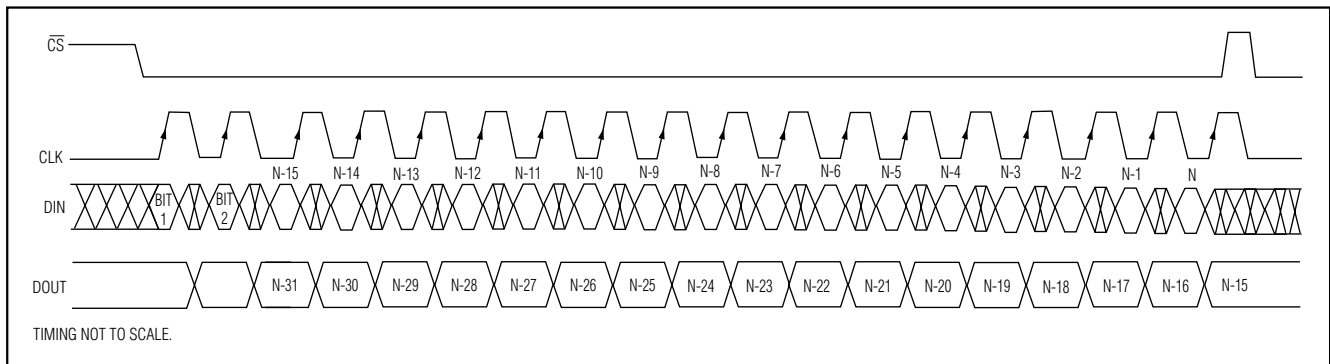

Figure 4. Transmission of More than 16 Bits to the MAX6952



# 4-Wire Interfaced, 2.7V to 5.5V, 4-Digit 5 × 7 Matrix LED Display Driver

**MAX6952**

**Table 4. Register Address Map**

REGISTER	ADDRESS (COMMAND BYTE)								HEX CODE
	D15	D14	D13	D12	D11	D10	D9	D8	
No-Op	R/W	0	0	0	0	0	0	0	0x00
Intensity10	R/W	0	0	0	0	0	0	1	0x01
Intensity32	R/W	0	0	0	0	0	1	0	0x02
Scan-Limit	R/W	0	0	0	0	0	1	1	0x03
Configuration	R/W	0	0	0	0	1	0	0	0x04
User-Defined Fonts	R/W	0	0	0	0	1	0	1	0x05
Factory reserved. Do not write to this.	R/W	0	0	0	0	1	1	0	0x06
Display Test	R/W	0	0	0	0	1	1	1	0x07
Digit 0 Plane P0	R/W	0	1	0	0	0	0	0	0x20
Digit 1 Plane P0	R/W	0	1	0	0	0	0	1	0x21
Digit 2 Plane P0	R/W	0	1	0	0	0	1	0	0x22
Digit 3 Plane P0	R/W	0	1	0	0	0	1	1	0x23
Digit 0 Plane P1	R/W	1	0	0	0	0	0	0	0x40
Digit 1 Plane P1	R/W	1	0	0	0	0	0	1	0x41
Digit 2 Plane P1	R/W	1	0	0	0	0	1	0	0x42
Digit 3 Plane P1	R/W	1	0	0	0	0	1	1	0x43
Write Digit 0 Plane P0 and Plane P1 with Same Data (Reads as 0x00)	R/W	1	1	0	0	0	0	0	0x60
Write Digit 1 Plane P0 and Plane P1 with Same Data (Reads as 0x00)	R/W	1	1	0	0	0	0	1	0x61
Write Digit 2 Plane P0 and Plane P1 with Same Data (Reads as 0x00)	R/W	1	1	0	0	0	1	0	0x62
Write Digit 3 Plane P0 and Plane P1 with Same Data (Reads as 0x00)	R/W	1	1	0	0	0	1	1	0x63

# 4-Wire Interfaced, 2.7V to 5.5V, 4-Digit 5 × 7 Matrix LED Display Driver

## Shutdown Mode (S Data Bit D0) Format

The S bit in the configuration register selects shutdown or normal operation (Table 7). The display driver can be programmed while in shutdown mode, and shutdown mode is overridden when in display test mode. For normal operation, the S bit should be set to 1.

## Blink Rate Selection (B Data Bit D2) Format

The B bit in the configuration register selects the blink rate. This is the speed that the segments alternate

between plane P0 and plane P1 refresh data. The blink rate is determined by the frequency of the multiplex clock OSC, in addition to the setting of the B bit (Table 8).

## Global Blink Enable/Disable (E Data Bit D3) Format

The E bit globally enables or disables the blink feature of the device (Table 9). When blink is globally enabled, then the digit data in both planes P0 and P1 are used to control the display (Table 10).

**Table 5. Initial Power-Up Register Status**

REGISTER	POWER-UP CONDITION	ADDRESS CODE (HEX)	REGISTER DATA							
			D7	D6	D5	D4	D3	D2	D1	D0
Intensity10	1/16 (min on)	0x01	0	0	0	0	0	0	0	0
Intensity32	1/16 (min on)	0x02	0	0	0	0	0	0	0	0
Scan Limit	Display 4 digits: 0 1 2 3	0x03	X	X	X	X	X	X	X	1
Configuration	Shutdown enabled, blink speed is slow, blink disabled	0x04	0	X	0	0	0	0	0	X
User-Defined Font Address Pointer	Address 0x80; pointing to the first user-defined font location	0x05	1	0	0	0	0	0	0	0
Display Test	Normal operation	0x07	X	X	X	X	X	X	X	0
Digit 0 Plane P0	Blank digit (0x20)	0x20	0	0	1	0	0	0	0	0
Digit 1 Plane P0	Blank digit (0x20)	0x21	0	0	1	0	0	0	0	0
Digit 2 Plane P0	Blank digit (0x20)	0x22	0	0	1	0	0	0	0	0
Digit 3 Plane P0	Blank digit (0x20)	0x23	0	0	1	0	0	0	0	0
Digit 0 Plane P1	Blank digit (0x20)	0x40	0	0	1	0	0	0	0	0
Digit 1 Plane P1	Blank digit (0x20)	0x41	0	0	1	0	0	0	0	0
Digit 2 Plane P1	Blank digit (0x20)	0x42	0	0	1	0	0	0	0	0
Digit 3 Plane P1	Blank digit (0x20)	0x43	0	0	1	0	0	0	0	0

**Table 6. Configuration Register Format**

REGISTER	REGISTER DATA							
	D7	D6	D5	D4	D3	D2	D1	D0
Configuration Register	P	X	R	T	E	B	X	S

**Table 7. Shutdown Control (S Data Bit D0) Format**

MODE	REGISTER DATA							
	D7	D6	D5	D4	D3	D2	D1	D0
Shutdown Mode	P	X	R	T	E	B	X	0
Normal Operation	P	X	R	T	E	B	X	1

# 4-Wire Interfaced, 2.7V to 5.5V, 4-Digit 5 × 7 Matrix LED Display Driver

When blink is globally disabled, then only the digit data in plane P0 is used to control the display. The digit data in plane P1 is ignored.

### Global Blink Timing Synchronization (T Data Bit D4) Format

By setting the T bit in multiple MAX6952s at the same time (or in quick succession), the blink timing can be synchronized across all the devices (Table 11). Note that the display multiplexing sequence is also reset, which might give rise to a one-time display flicker when the register is written.

### Global Clear Digit Data (R Data Bit D5) Format

When global digit data clear is set, the digit data for both planes P0 and P1 for all digits is cleared (Table 12).

### Blink Phase Readback (P Data Bit D7) Format

When the configuration register is read, the P bit reflects the state of the blink output pin at that time (Table 13).

### Character Generator Font Mapping

The font is a 5 × 7 matrix comprising 104 characters in ROM, and 24 user-definable characters. The selection from the total of 128 characters is represented by the lower 7 bits of the 8-bit digit registers. The most-significant bit, shown as x in the ROM map below, is zero to light LEDs as shown by the black segments in Table 14, and 1 to display the inverse.

The character map follows the Arial font for 96 characters in the x0101000 through x1111111 range. The first

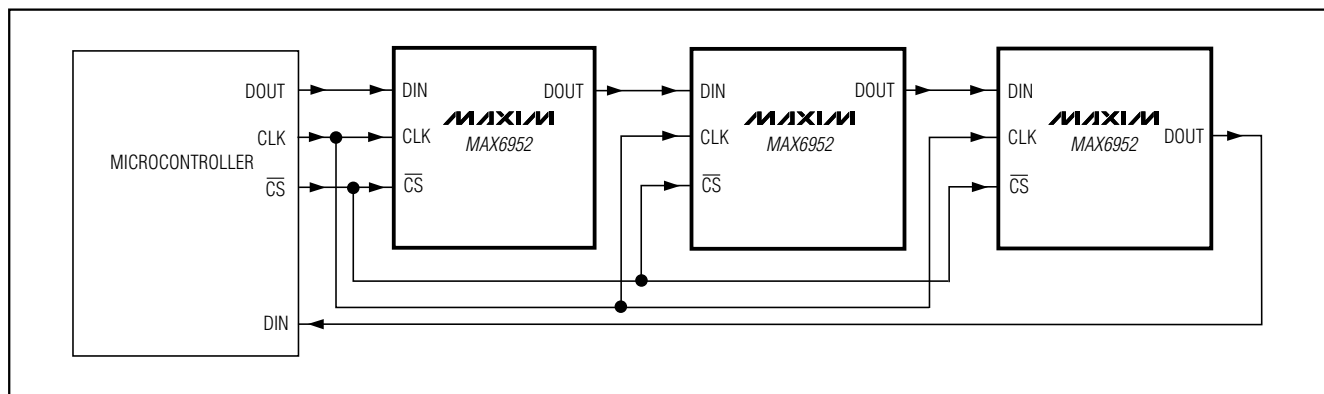

Figure 6. MAX6952 Daisy-Chain Connection

Table 8. Blink Rate Selection (B Data Bit D2) Format

MODE	REGISTER DATA							
	D7	D6	D5	D4	D3	D2	D1	D0
Slow blinking (Segments are refreshed using plane P0 for 1s, plane P1 for 1s, for OSC = 4MHz.)	P	X	R	T	E	0	X	S

Table 9. Global Blink Enable/Disable (E Data Bit D3) Format

MODE	REGISTER DATA							
	D7	D6	D5	D4	D3	D2	D1	D0
Blink function is disabled.	P	X	R	T	0	B	X	S
Blink function is enabled.	P	X	R	T	1	B	X	S

## 4-Wire Interfaced, 2.7V to 5.5V, 4-Digit 5 × 7 Matrix LED Display Driver

**Table 10. Digit Register Mapping with Blink Globally Enabled**

SEGMENT'S BIT SETTING IN PLANE P1	SEGMENT'S BIT SETTING IN PLANE P0	SEGMENT BEHAVIOR
0	0	Segment off
0	1	Segment on only during the 1st half of each blink period
1	0	Segment on only during the 2nd half of each blink period
1	1	Segment on

32 characters map the 24 user-definable positions (RAM00 to RAM23), plus eight extra common characters in ROM.

### User-Defined Fonts

The 24 user-definable characters are represented by 120 entries of 7-bit data, five entries per character, and are stored in the MAX6952's internal RAM.

The 120 user-definable font data entries are written and read through a single register, address 0x05. An autoincrementing font address pointer in the MAX6952

indirectly accesses the font data. The font address pointer can be written, setting one of 120 addresses between 0x00 and 0xF7, but cannot be read back. The font data is written to and read from the MAX6952 indirectly, using this font address pointer. Unused font locations can be used as general-purpose scratch RAM, bearing in mind that the font registers are only 7 bits wide, not 8.

Table 15 shows how the single user-defined font register 0x05 is used to set the font address pointer, write font data, and read font data. A read action always returns font data from the font address pointer position. A write action sets the 7-bit font address pointer if the MSB is set, or writes 7-bit font data to the font address pointer position if the MSB is clear.

The font address pointer autoincrements after a valid access to the user-definable font data. Autoincrementing allows the 120 font data entries to be written and read back very quickly because the font pointer address need only be set once. When the last data location 0xF7 is written, the font address pointer autoincrements to address 0x80. If the font address pointer is set to an out-of-range address by writing data in the 0xF8 to 0xFF range, then address 0x80 is set instead (Table 16).

Table 17 shows the user-definable font pointer base addresses.

**Table 11. Global Blink Timing Synchronization (T Data Bit D4) Format**

MODE	REGISTER DATA							
	D7	D6	D5	D4	D3	D2	D1	D0
Blink timing counters are unaffected.	P	X	R	0	E	B	X	S
Blink timing counters are reset on the rising edge of $\overline{CS}$ .	P	X	R	1	E	B	X	S

**Table 12. Global Clear Digit Data (R Data Bit D5) Format**

MODE	REGISTER DATA							
	D7	D6	D5	D4	D3	D2	D1	D0
Digit data for both planes P0 and P1 are unaffected.	P	X	0	T	E	B	X	S
Digit data for both planes P0 and P1 are cleared on the rising edge of $\overline{CS}$ .	P	X	1	T	E	B	X	S

**Table 13. Blink Phase Readback (P Data Bit D7) Format**

MODE	REGISTER DATA							
	D7	D6	D5	D4	D3	D2	D1	D0
P1 Blink Phase	0	X	R	T	E	B	X	S
P0 Blink Phase	1	X	R	T	E	B	X	S

# 4-Wire Interfaced, 2.7V to 5.5V, 4-Digit 5 × 7 Matrix LED Display Driver

MAX6952

Table 14. Character Map

MSB LSB	x000	x001	x010	x011	x100	x101	x110	x111
0000	RAM00	RAM16						
0001	RAM01	RAM17						
0010	RAM02	RAM18						
0011	RAM03	RAM19						
0100	RAM04	RAM20						
0101	RAM05	RAM21						
0110	RAM06	RAM22						
0111	RAM07	RAM23						
1000	RAM08							
1001	RAM09							
1010	RAM10							
1011	RAM11							
1100	RAM12							
1101	RAM13							
1110	RAM14							
1111	RAM15							

Table 18 shows an example of data (characters 0, 1, and 2) being stored in the first three user-defined font locations, illustrating the orientation of the data bits.

Table 19 shows the six sequential write commands required to set a MAX6953's font character RAM02 with the data to display character 2 given in the font RAM illustration above.

### Multiplex Clock and Blink Timing

The OSC pin can be fitted with capacitor C<sub>SET</sub> to GND (to use the internal RC multiplex oscillator), or driven by an external clock. The multiplex clock frequency determines the multiplex scan rate and the blink timing. The display scan rate is calculated by dividing the frequency at OSC by 5600. With OSC at 4 MHz, each display digit is enabled for 100µs and the display scan rate is 714.29Hz.

The on-chip oscillator may be accurate enough for applications using a single device. If an exact blink rate is required, use an external clock ranging between 1MHz and 8MHz to drive OSC. The OSC inputs of multiple MAX6952s can be tied together to a common external clock to make the devices blink at the same rate. The relative blink phasing of multiple MAX6952s can be synchronized by setting the T bit in the control register for all the devices in quick succession (Table 11).

If the serial interfaces of multiple MAX6952s are daisy-chained by connecting DOUT of one device to DIN of the next, then synchronization is achieved automatically by updating the control register for all devices together. For MAX6952s, the devices can be synchronized by transmitting the serial data for the control register, and then toggling the  $\overline{CS}$  pin for each device, either together or in quick succession. Figure 7 is the multiplex timing diagram.

### Blink Output

The blink output indicates the blink phase, and is high during the P0 period and low during the P1 period. Blink phase status can also be read back as the P bit in the configuration register (Table 13). Typical uses for this output are:

- To provide an interrupt to the processor so that segment data can be changed synchronous to the blinking. For example, a clock application may have colon segments blinking every second between hours and minute digits, and the minute display is best changed in step with the colon segments. Also, if the rising edge of blink is detected, there is half a blink period to change the P1 digit data. Similarly, if the falling edge of blink is detected, the user has half a blink period to change the P0 digit data.

# 4-Wire Interfaced, 2.7V to 5.5V, 4-Digit 5 × 7 Matrix LED Display Driver

**Table 15. Memory Mapping of User-Defined Font Register 0x05**

ADDRESS CODE (HEX)	REGISTER DATA	SPI READ OR WRITE	FUNCTION
0x85	0x00–0x7F	Read	Read 7-bit user-definable font data entry from current font address. MSB of the register data is clear. Font address pointer is incremented after the read.
0x05	0x00–0x7F	Write	Write 7-bit user-definable font data entry to current font address. Font address pointer is incremented after the write.
0x05	0x80–0xFF	Write	Write font address pointer with the register data.

**Table 16. Font Pointer Address Behavior**

FONT POINTER ADDRESS	ACTION
0x80 to 0xF6	Valid range to set the font address pointer. Pointer autoincrements after a font data read or write, while pointer address remains in this range.
0xF7	Font address resets to 0x80 after a font data read or write to this pointer address.
0xF8 to 0xFF	Invalid range to set the font address pointer. Pointer is set to 0x80 if address.

- If OSC is driven with an accurate frequency, blink can be used as a seconds counter or similar.

### Scan-Limit Register

The scan-limit register sets how many monochrome digits are displayed, either two or four. A bicolor digit is connected as two monochrome digits.

The multiplexing scheme drives digits 0 and 1 at the same time, then digits 2 and 3 at the same time. To increase the effective brightness of the displays, drive only two digits instead of four. By doing this, the average segment current doubles, but also doubles the number of MAX6952s required to drive a given number of digits.

Because digit 1 is driven at the same time as digit 0 (and digit 3 is driven at the same time as digit 2), only 1 bit is used to set the scan limit. The bit is clear if one or two digits are to be driven, and set if three or four digits are to be driven (Table 20). Change the scan-limit register only when the MAX6952 is in shutdown mode.

### Intensity Registers

Display brightness is controlled digitally by four pulse-width modulators, one for each display digit. Each digit is controlled by a nibble of one of the two intensity registers, Intensity10 and Intensity32. The modulator scales the average segment current in 16 steps from a maximum of 15/16 down to 1/16 of the peak current. The minimum interdigit blanking time is, therefore, 1/16 of a cycle. The maximum duty cycle is 15/16. (Tables 21 and 22).

### No-Op Register

A write to the no-op register is ignored.

### Selecting External Components RSET and CSET to Set Oscillator Frequency and Segment Current

The RC oscillator uses an external resistor RSET and an external capacitor CSET to set the oscillator frequency, fOSC. The allowed range of fOSC is 1MHz to 8MHz. RSET also sets the peak segment current. The recommended values of RSET and CSET set the oscillator to 4MHz, which makes the blink frequencies 0.5Hz and 1Hz. The recommended value of RSET also sets the peak current to 40mA, which makes the segment current adjustable from 2.5mA to 37.5mA in 2.5mA steps:

$$I_{SEG} = K_I / R_{SET} \text{ mA}$$

$$f_{OSC} = K_F / (R_{SET} \times C_{SET} + C_{STRAY}) \text{ MHz}$$

Where:

$$K_I = 2144$$

$$K_F = 6000$$

RSET = external resistor in kΩ

CSET = external capacitor in pF

CSTRAY = stray capacitance from OSC pin to GND in pF, typically 2pF

The recommended value of RSET is 53.6kΩ and the recommended value of CSET is 26pF.

# 4-Wire Interfaced, 2.7V to 5.5V, 4-Digit 5 × 7 Matrix LED Display Driver

**MAX6952**

**Table 17. User-Definable Font Pointer Base Address Table**

FONT CHARACTER	ADDRESS CODE (HEX)	REGISTER DATA (HEX)	REGISTER DATA							
			D7	D6	D5	D4	D3	D2	D1	D0
RAM00	0x05	0x80	1	0	0	0	0	0	0	0
RAM01	0x05	0x85	1	0	0	0	0	1	0	1
RAM02	0x05	0x8A	1	0	0	0	1	0	1	0
RAM03	0x05	0x8F	1	0	0	0	1	1	1	1
RAM04	0x05	0x94	1	0	0	1	0	1	0	0
RAM05	0x05	0x99	1	0	0	1	1	0	0	1
RAM06	0x05	0x9E	1	0	0	1	1	1	1	0
RAM07	0x05	0xA3	1	0	1	0	0	0	1	1
RAM08	0x05	0xA8	1	0	1	0	1	0	0	0
RAM09	0x05	0xAD	1	0	1	0	1	1	0	1
RAM10	0x05	0xB2	1	0	1	1	0	0	1	0
RAM11	0x05	0xB7	1	0	1	1	0	1	1	1
RAM12	0x05	0xBC	1	0	1	1	1	1	0	0
RAM13	0x05	0xC1	1	1	0	0	0	0	0	1
RAM14	0x05	0xC6	1	1	0	0	0	1	1	0
RAM15	0x05	0xCB	1	1	0	0	1	0	1	1
RAM16	0x05	0xD0	1	1	0	1	0	0	0	0
RAM17	0x05	0xD5	1	1	0	1	0	1	0	1
RAM18	0x05	0xDA	1	1	0	1	1	0	1	0
RAM19	0x05	0xDF	1	1	0	1	1	1	1	1
RAM20	0x05	0xE4	1	1	1	0	0	1	0	0
RAM21	0x05	0xE9	1	1	1	0	1	0	0	1
RAM22	0x05	0xEE	1	1	1	0	1	1	1	0
RAM23	0x05	0xF3	1	1	1	1	0	0	1	1

The recommended value of RSET is the minimum allowed value since it sets the display driver to the maximum allowed segment current. RSET can be set to a higher value to set the segment current to a lower peak value where desired. The user must also ensure that the peak current specifications of the LEDs connected to the driver are not exceeded.

The effective value of CSET includes not only the actual external capacitor used, but also the stray capacitance from OSC to GND. This capacitance is usually in the 1pF to 5pF range, depending on the layout used.

### **Display-Test Register**

The display-test register switches the drivers between one of two modes: normal and display test. Display-test mode turns all LEDs on by overriding, but not altering, all control and digit registers (including the shutdown

register). In display-test mode, eight digits are scanned and the duty cycle is 7/16 (half power). Table 23 lists the display-test register format.

## **Applications Information**

### **Choosing Supply Voltage to Minimize Power Dissipation**

The MAX6952 drives a peak current of 40mA into LEDs with a 2.4V forward-voltage drop when operated from a supply voltage of at least 3.0V. The minimum voltage drop across the internal LED drivers is, therefore (3.0V - 2.4V) = 0.6V. If a higher supply voltage is used, the driver absorbs a higher voltage, and the driver's power dissipation increases accordingly. However, if the LEDs used have a higher forward voltage drop than 2.4V, the supply voltage must be raised accordingly to ensure that the driver always has at least 0.6V headroom.

# 4-Wire Interfaced, 2.7V to 5.5V, 4-Digit 5 × 7 Matrix LED Display Driver

**Table 18. User-Definable Character Storage Example**

FONT CHARACTER	FONT ADDRESS POINTER	ADDRESS CODE (HEX)	FONT POINTER ADDRESS (HEX)	REGISTER DATA							
				D7	D6	D5	D4	D3	D2	D1	D0
RAM00	0x00	0x05	0x80	0	0	1	1	1	1	1	0
RAM00	0x01	0x05	0x81	0	1	0	1	0	0	0	1
RAM00	0x02	0x05	0x82	0	1	0	0	1	0	0	1
RAM00	0x03	0x05	0x83	0	1	0	0	0	1	0	1
RAM00	0x04	0x05	0x84	0	0	1	1	1	1	1	0
RAM01	0x05	0x05	0x85	0	0	0	0	0	0	0	0
RAM01	0x06	0x05	0x86	0	1	0	0	0	0	1	0
RAM01	0x07	0x05	0x87	0	1	1	1	1	1	1	1
RAM01	0x08	0x05	0x88	0	1	0	0	0	0	0	0
RAM01	0x09	0x05	0x89	0	0	0	0	0	0	0	0
RAM02	0x0A	0x05	0x8A	0	1	0	0	0	0	1	0
RAM02	0x0B	0x05	0x8B	0	1	1	0	0	0	0	1
RAM02	0x0C	0x05	0x8C	0	1	0	1	0	0	0	1
RAM02	0x0D	0x05	0x8D	0	1	0	0	1	0	0	1
RAM02	0x0E	0x05	0x8E	0	1	0	0	0	1	1	0

**Table 19. Setting a Font Character to RAM Example**

ADDRESS CODE (HEX)	REGISTER DATA (HEX)	ACTION BEING PERFORMED
0x05	0x8A	Set font address pointer to the base address of font character RAM02.
0x05	0x42	1st 7 bits of data: 100010 goes to font address 0x8A; pointer then autoincrements to address 0x8B.
0x05	0x61	2nd 7 bits of data: 110001 goes to font address 0x8B; pointer then autoincrements to address 0x8C.
0x05	0x51	3rd 7 bits of data: 1010001 goes to font address 0x8C; pointer then autoincrements to address 0x8D.
0x05	0x49	4th 7 bits of data: 1001001 goes to font address 0x8D; pointer then autoincrements to address 0x8E.
0x05	0x46	5th 7 bits of data: 1000110 goes to font address 0x8E; pointer then autoincrements to address 0x8F.

**Table 20. Scan Limit Register Format**

SCAN LIMIT	ADDRESS CODE (HEX)	REGISTER DATA								HEX CODE
		D7	D6	D5	D4	D3	D2	D1	D0	
Display digits 0 and 1 only	0x03	X	X	X	X	X	X	X	0	0xX0
Display digits 0, 1, 2, and 3	0x03	X	X	X	X	X	X	X	1	0xX1



# 4-Wire Interfaced, 2.7V to 5.5V, 4-Digit 5 × 7 Matrix LED Display Driver

**MAX6952**

**Table 21. Intensity Register Format for Digit 0 (Address 0x01) and Digit 2 (Address 0x02)**

DUTY CYCLE	TYPICAL SEGMENT CURRENT (mA)	ADDRESS CODE (HEX)	D7	D6	D5	D4	D3	D2	D1	D0	HEX CODE	
1/16 (min on)	2.5	0x01, 0x02	See Table 22.				0	0	0	0	0	0xX0
2/16	5	0x01, 0x02					0	0	0	1	0xX1	
3/16	7.5	0x01, 0x02					0	0	1	0	0xX2	
4/16	10	0x01, 0x02					0	0	1	1	0xX3	
5/16	12.5	0x01, 0x02					0	1	0	0	0xX4	
6/16	15	0x01, 0x02					0	1	0	1	0xX5	
7/16	17.5	0x01, 0x02					0	1	1	0	0xX6	
8/16	20	0x01, 0x02					0	1	1	1	0xX7	
9/16	22.5	0x01, 0x02					1	0	0	0	0xX8	
10/16	25	0x01, 0x02					1	0	0	1	0xX9	
11/16	27.5	0x01, 0x02					1	0	1	0	0xXA	
12/16	30	0x01, 0x02					1	0	1	1	0xXB	
13/16	32.5	0x01, 0x02					1	1	0	0	0xXC	
14/16	35	0x01, 0x02					1	1	0	1	0xXD	
15/16	37.5	0x01, 0x02					1	1	1	0	0xXE	
15/16 (max on)	37.5	0x01, 0x02					1	1	1	1	0xXF	

**Table 22. Intensity Register Format for Digit 1 (Address 0x01) and Digit 3 (Address 0x02)**

DUTY CYCLE	TYPICAL SEGMENT CURRENT (mA)	ADDRESS CODE (HEX)	D7	D6	D5	D4	D3	D2	D1	D0	HEX CODE
1/16 (min on)	2.5	0x01, 0x02	0	0	0	0	See Table 21.				0x0X
2/16	5	0x01, 0x02	0	0	0	1					0x1X
3/16	7.5	0x01, 0x02	0	0	1	0					0x2X
4/16	10	0x01, 0x02	0	0	1	1					0x3X
5/16	12.5	0x01, 0x02	0	1	0	0					0x4X
6/16	15	0x01, 0x02	0	1	0	1					0x5X
7/16	17.5	0x01, 0x02	0	1	1	0					0x6X
8/16	20	0x01, 0x02	0	1	1	1					0x7X
9/16	22.5	0x01, 0x02	1	0	0	0					0x8X
10/16	25	0x01, 0x02	1	0	0	1					0x9X
11/16	27.5	0x01, 0x02	1	0	1	0					0xAx
12/16	30	0x01, 0x02	1	0	1	1					0xBx
13/16	32.5	0x01, 0x02	1	1	0	0					0xCx
14/16	35	0x01, 0x02	1	1	0	1					0xDx
15/16	37.5	0x01, 0x02	1	1	1	0					0xEx
15/16 (max on)	37.5	0x01, 0x02	1	1	1	1					0xFx

## 4-Wire Interfaced, 2.7V to 5.5V, 4-Digit 5 × 7 Matrix LED Display Driver

Table 23. Display-Test Register Format

MODE	ADDRESS CODE (HEX)	REGISTER DATA							
		D7	D6	D5	D4	D3	D2	D1	D0
Normal operation	0x07	X	X	X	X	X	X	X	0
Display test	0x07	X	X	X	X	X	X	X	1

The voltage drop across the drivers with a nominal 5V supply (5.0V - 2.4V) = 2.6V is nearly 3 times the drop across the drivers with a nominal 3.3V supply (3.3V - 2.4V) = 0.9V. In most systems, consumption is an important design criterion, and the MAX6952 should be operated from the system's 3.3V nominal supply. In other designs, the lowest supply voltage may be 5V. The issue now is to ensure the dissipation limit for the MAX6952 is not exceeded. This can be achieved by inserting a series resistor in the supply to the MAX6952, ensuring that the supply decoupling capacitors are still on the MAX6952 side of the resistor. For example, consider the requirement that the minimum supply voltage to a MAX6952 must be 3.0V, and the input supply range is 5V ±5%.

Maximum supply current is:

$$12\text{mA} + (40\text{mA} \times 10) = 412\text{mA}$$

Minimum input supply voltage is 4.75V.

Maximum series resistor value is:

$$(4.75\text{V} - 3.0\text{V}) / 0.412\text{A} = 4.25\Omega$$

We choose 3.3Ω ±5%. Worst-case resistor dissipation is at maximum toleranced resistance, i.e., (0.412A) 2 × (3.3Ω × 1.05) = 0.577W. We choose a 1W resistor rating. The maximum MAX6952 supply voltage is at maximum input supply voltage and minimum toleranced resistance, i.e., 5.25V - (0.412A × 3.3Ω × 0.95) = 3.97V.

### Low-Voltage Operation

The MAX6952 works over the 2.7V to 5.5V supply range. The minimum useful supply voltage is determined by the forward voltage drop of the LEDs at the peak current I<sub>SEG</sub>, plus the 0.6V headroom required by the driver output stages. The MAX6952 correctly regulates I<sub>SEG</sub> with a supply voltage above this minimum voltage. If the supply drops below this minimum voltage, the driver output stages may brown out, and be unable to regulate the current correctly. As the supply voltage drops further, the LED segment drive current becomes effectively limited by the output driver's on-resistance, and the LED drive current drops. The characteristics of each individual LED in a 5 × 7 matrix digit are well matched, so the result is that the display inten-

sity dims uniformly as supply voltage drops out of regulation and beyond. The MAX6952 operates down to 2.5V supply voltage (although most displays are very dim at this voltage), provided that the MAX6952 is powered up initially to at least 2.7V to trigger the device's internal reset.

### Computing Power Dissipation

The upper limit for power dissipation (PD) for the MAX6952 is determined from the following equation:

$$P_D = (V_+ \times 12\text{mA}) + (V_+ - V_{LED}) (\text{DUTY} \times I_{SEG} \times N)$$

where:

V<sub>+</sub> = supply voltage

Duty = duty cycle set by intensity register

N = number of segments driven (worst case is 10)

V<sub>LED</sub> = LED forward voltage

I<sub>SEG</sub> = segment current set by RSET

P<sub>D</sub> = power dissipation, in mW if currents are in mA

Dissipation example:

$$I_{SEG} = 40\text{mA}, N = 10, \text{Duty} = 15 / 16, V_{LED} = 2.4\text{V at } 40\text{mA}, V_+ = 3.6\text{V}$$

$$P_D = 3.6\text{V} (12\text{mA}) + (3.6\text{V} - 2.4\text{V})(15 / 16 \times 40\text{mA} \times 10) = 0.493\text{W}$$

Thus, for a 36-pin SSOP package (T<sub>JA</sub> = 1 / 0.0118 = +85°C/W from operating ratings), the maximum allowed ambient temperature T<sub>A</sub> is given by:

$$T_{J(\text{MAX})} = T_A + (P_D \times T_{JA}) = +150^\circ\text{C} = T_A + (0.493 \times +85^\circ\text{C/W})$$

So, T<sub>A</sub> = +108°C. Thus, the part can be operated safely at a maximum package temperature of +85°C.

### Power Supplies

The MAX6952 operates from a single 2.7V to 5.5V power supply. Bypass the power supply to GND with a 0.1μF capacitor as close to the device as possible. Add a 47μF capacitor if the MAX6952 is not close to the board's input bulk decoupling capacitor.

# 4-Wire Interfaced, 2.7V to 5.5V, 4-Digit 5 × 7 Matrix LED Display Driver

**MAX6952**

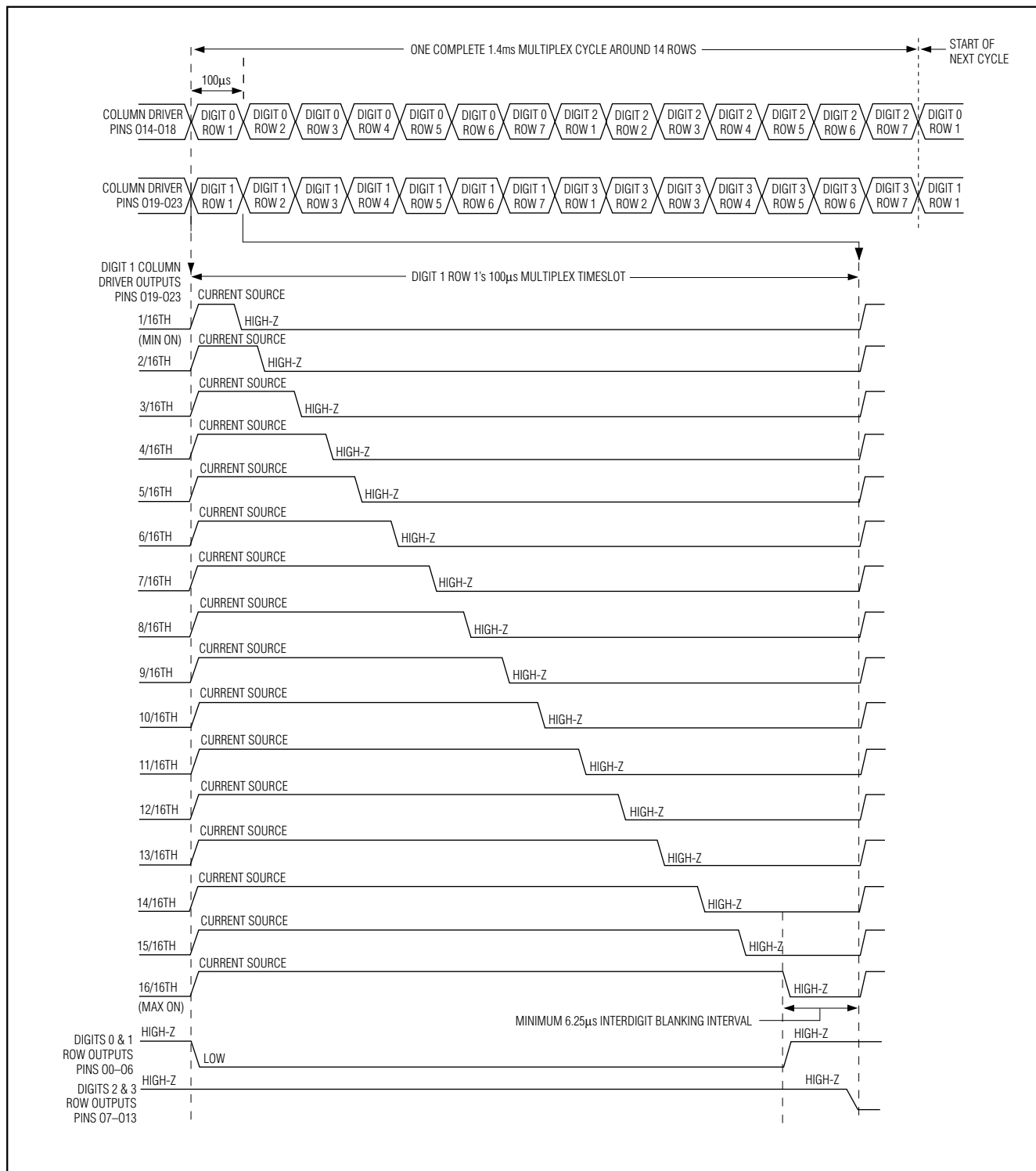

Figure 7. Multiplex Timing Diagram (OSC = 4MHz)

# 4-Wire Interfaced, 2.7V to 5.5V, 4-Digit 5 × 7 Matrix LED Display Driver

## Board Layout

When designing a board, use the following guidelines:

- 1) The RSET connection to the ISET pin is a high-impedance node, and sensitive to layout. Place RSET right next to the ISET pin and route RSET directly to these pins with very short tracks.
- 2) Ensure that the track from the ground end of RSET routes directly to GND pin 18 (PDIP package) or GND pin 16 (SSOP package), and that this track is not used as part of any other ground connection.

## Chip Information

TRANSISTOR COUNT: 43,086

PROCESS: CMOS

## Pin Configurations

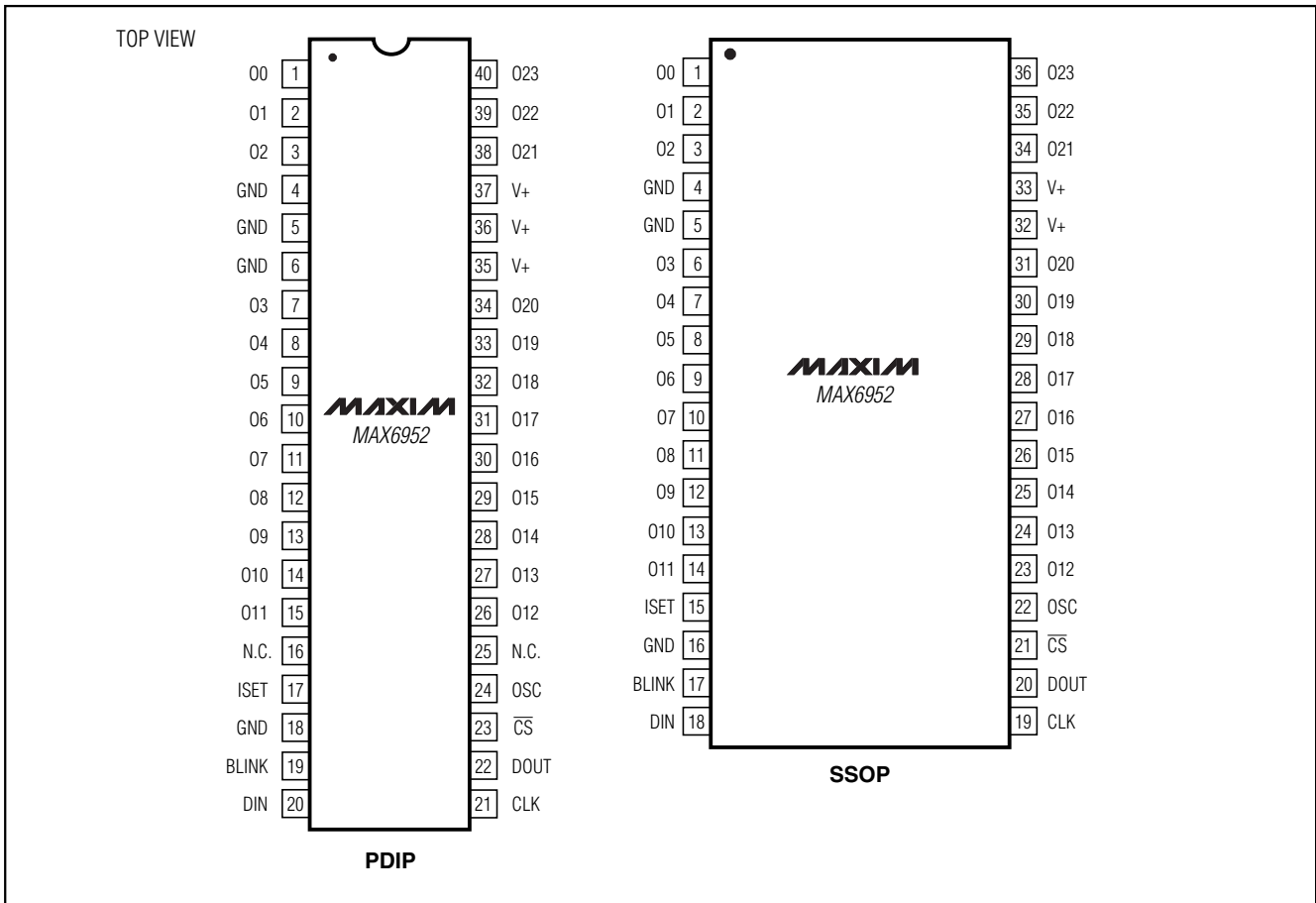

# 4-Wire Interfaced, 2.7V to 5.5V, 4-Digit 5 × 7 Matrix LED Display Driver

## Package Information

(The package drawing(s) in this data sheet may not reflect the most current specifications. For the latest package outline information, go to [www.maxim-ic.com/packages](http://www.maxim-ic.com/packages).)

**MAX6952**

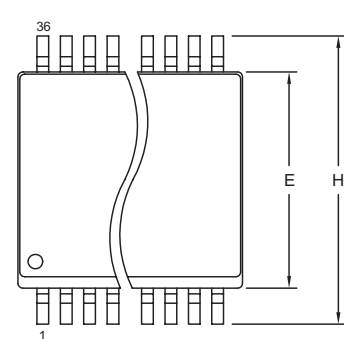

TOP VIEW

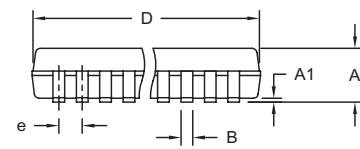

FRONT VIEW

DIM	INCHES		MILLIMETERS	
	MIN	MAX	MIN	MAX
A	0.096	0.104	2.44	2.65
A1	0.004	0.011	0.10	0.29
B	0.012	0.017	0.30	0.44
C	0.009	0.013	0.23	0.32
e	0.0315 BSC		0.80 BSC	
E	0.291	0.299	7.40	7.60
H	0.398	0.414	10.11	10.51
L	0.020	0.040	0.51	1.02
D	0.598	0.612	15.20	15.55

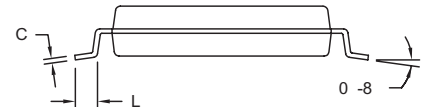

SIDE VIEW

**NOTES:**

1. D&E DO NOT INCLUDE MOLD FLASH.
2. MOLD FLASH OR PROTRUSIONS NOT TO EXCEED 0.15mm (.006").
3. LEADS TO BE COPLANAR WITHIN 0.10mm (.004").
4. CONTROLLING DIMENSION: MILLIMETERS.

<b>DALLAS SEMICONDUCTOR</b> <b>MAXIM</b>		
<small>PROPRIETARY INFORMATION</small>		
<small>TITLE:</small> PACKAGE OUTLINE, 36L SSOP, 0.80 MM PITCH		
<small>APPROVAL:</small>	<small>DOCUMENT CONTROL NO.</small> 21-0040	<small>REV.</small> E 1/1

SSOP-EPS

Maxim cannot assume responsibility for use of any circuitry other than circuitry entirely embodied in a Maxim product. No circuit patent licenses are implied. Maxim reserves the right to change the circuitry and specifications without notice at any time.

21 \_\_\_\_\_ **Maxim Integrated Products, 120 San Gabriel Drive, Sunnyvale, CA 94086 408-737-7600**