



Ultra-Small, Adjustable Sequencing/Supervisory Circuits

General Description

The MAX6895–MAX6899 is a family of small, low-power, voltage-monitoring circuits with sequencing capability. These miniature devices offer tremendous flexibility with an adjustable threshold capable of monitoring down to 0.5V and an external capacitor-adjustable time delay. These devices are ideal for use in power-supply sequencing, reset sequencing, and power-switching applications. Multiple devices can be cascaded for complex sequencing applications.

A high-impedance input with a 0.5V threshold allows an external resistive divider to set the monitored threshold. The output asserts ($\text{OUT} = \text{high}$ or $\overline{\text{OUT}} = \text{low}$) when the input voltage rises above the 0.5V threshold and the enable input is asserted ($\text{ENABLE} = \text{high}$ or $\overline{\text{ENABLE}} = \text{low}$). When the voltage at the input falls below 0.5V or when the enable input is deasserted ($\text{ENABLE} = \text{low}$ or $\overline{\text{ENABLE}} = \text{high}$), the output deasserts ($\text{OUT} = \text{low}$ or $\overline{\text{OUT}} = \text{high}$). All devices provide a capacitor-programmable delay time from when the input rises above 0.5V to when the output is asserted. The MAX689_A versions provide the same capacitor-adjustable delay from when enable is asserted to when the output asserts. The MAX689_P devices have a 1 μs propagation delay from when enable is asserted to when the output asserts.

The MAX6895A/P offers an active-high enable input and an active-high push-pull output. The MAX6896A/P offers an active-low enable input and an active-low push-pull output. The MAX6897A/P offers an active-high enable input and an active-high open-drain output. Finally, the MAX6898A/P offers an active-low enable input and an active-low open-drain output. The MAX6899A/P offers an active-low enable with an active-high push-pull output.

All devices operate from a 1.5V to 5.5V supply voltage and are fully specified over the -40°C to $+125^{\circ}\text{C}$ operating temperature range. These devices are available in ultra-small 6-pin μDFN (1.0mm x 1.5mm) and thin SOT23 (1.60mm x 2.90mm) packages.

Applications

Automotive	Computers/Servers
Medical Equipment	Critical μP Monitoring
Intelligent Instruments	Set-Top Boxes
Portable Equipment	Telecom

Typical Operating Circuit and Selector Guide appear at end of data sheet.

Features

- ◆ 1.8% Accurate Adjustable Threshold Over Temperature
- ◆ Operate from V_{CC} of 1.5V to 5.5V
- ◆ Capacitor-Adjustable Delay
- ◆ Active-High/Low Enable Input Options
- ◆ Active-High/Low Output Options
- ◆ Open-Drain (28V Tolerant)/Push-Pull Output Options
- ◆ Low Supply Current (10 μA , typ)
- ◆ Fully Specified from -40°C to $+125^{\circ}\text{C}$
- ◆ Ultra-Small 6-Pin μDFN Package or Thin SOT23 Package

Ordering Information

PART	PIN-PACKAGE	TOP MARK
MAX6895AALT+	6 μDFN	+AW
MAX6895AAZT+	6 Thin SOT23	+AADK
MAX6895PALT+T	6 μDFN	+AX
MAX6895PAZT+	6 Thin SOT23	+AADL
MAX6896AALT+	6 μDFN	+AY
MAX6896AAZT+	6 Thin SOT23	+AADO
MAX6896AAZT/V+T	6 Thin SOT23	+AATA
MAX6896PALT+T	6 μDFN	+AZ
MAX6896PAZT+	6 Thin SOT23	+AADP
MAX6896PAZT/V+T	6 Thin SOT23	

Ordering Information continued at end of data sheet.

Note: All devices are specified over the -40°C to $+125^{\circ}\text{C}$ operating temperature range.

+ Denotes a lead(Pb)-free/RoHS-compliant package.

T = Tape and reel.

Pin Configurations

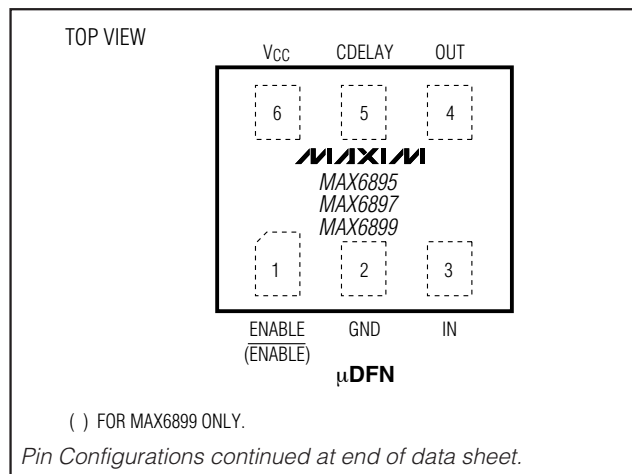

Ultra-Small, Adjustable Sequencing/Supervisory Circuits

ABSOLUTE MAXIMUM RATINGS

V_{CC} , \overline{ENABLE} , \overline{IN}	-0.3V to +6V
OUT, \overline{OUT} (push-pull)	-0.3V to ($V_{CC} + 0.3V$)
OUT, \overline{OUT} (open-drain)	-0.3V to +30V
CDELAY.....	-0.3V to ($V_{CC} + 0.3V$)
Output Current (all pins).....	$\pm 20mA$
Continuous Power Dissipation ($T_A = +70^\circ C$)	
6-Pin μDFN (derate 2.1mW/ $^\circ C$ above +70 $^\circ C$).....	167.7mW
6-Pin Thin SOT23 (derate 9.1mW/ $^\circ C$ above +70 $^\circ C$) ...	727.3mW

Operating Temperature Range	-40 $^\circ C$ to +125 $^\circ C$
Storage Temperature Range	-65 $^\circ C$ to +150 $^\circ C$
Junction Temperature	+150 $^\circ C$
Lead Temperature (soldering, 10s)	+300 $^\circ C$
Soldering Temperature (reflow)	+260 $^\circ C$

Stresses beyond those listed under "Absolute Maximum Ratings" may cause permanent damage to the device. These are stress ratings only, and functional operation of the device at these or any other conditions beyond those indicated in the operational sections of the specifications is not implied. Exposure to absolute maximum rating conditions for extended periods may affect device reliability.

PACKAGE THERMAL CHARACTERISTICS (Note 1)

μDFN	Thin SOT23
Junction-to-Ambient Thermal Resistance (θ_{JA}).....	477 $^\circ C/W$
Junction-to-Ambient Thermal Resistance (θ_{JA}).....	110 $^\circ C/W$
Junction-to-Case Thermal Resistance (θ_{JC}).....	122 $^\circ C/W$
Junction-to-Case Thermal Resistance (θ_{JC}).....	50 $^\circ C/W$

Note 1: Package thermal resistances were obtained using the method described in JEDEC specification JESD51-7, using a four layer board. For detailed information on package thermal considerations refer to www.maxim-ic.com/thermal-tutorial.

ELECTRICAL CHARACTERISTICS

($V_{CC} = 1.5V$ to $5.5V$, $T_A = -40^\circ C$ to $+125^\circ C$, unless otherwise specified. Typical values are at $V_{CC} = 3.3V$ and $T_A = +25^\circ C$, unless otherwise noted.) (Note 2)

PARAMETER	SYMBOL	CONDITIONS	MIN	TYP	MAX	UNITS
SUPPLY						
Operating Voltage Range	V_{CC}		1.5		5.5	V
Undervoltage Lockout (Note 3)	UVLO	V_{CC} falling	1.20		1.35	V
V_{CC} Supply Current	I_{CC}	$V_{CC} = 3.3V$, no load		10	20	μA
IN						
Threshold Voltage	V_{TH}	V_{IN} rising, $1.5V < V_{CC} < 5.5V$	0.491	0.5	0.509	V
Hysteresis	V_{HYST}	V_{IN} falling		5		mV
Input Current (Note 4)	I_{IN}	$V_{IN} = 0V$ or V_{CC}	-15		+15	nA
CDELAY						
Delay Charge Current	I_{CD}		200	250	300	nA
Delay Threshold	V_{TCD}	CDELAY rising	0.95	1.00	1.05	V
CDELAY Pulldown Resistance	R_{CDELAY}			130	500	Ω
ENABLE/\overline{ENABLE}						
Input Low Voltage	V_{IL}				0.4	V
Input High Voltage	V_{IH}		1.4			V
Input Leakage Current	I_{LEAK}	ENABLE, $\overline{ENABLE} = V_{CC}$ or GND	-100		+100	nA

Ultra-Small, Adjustable Sequencing/Supervisory Circuits

MAX6895-MAX6899

ELECTRICAL CHARACTERISTICS (continued)

($V_{CC} = 1.5V$ to $5.5V$, $T_A = -40^{\circ}C$ to $+125^{\circ}C$, unless otherwise specified. Typical values are at $V_{CC} = 3.3V$ and $T_A = +25^{\circ}C$, unless otherwise noted.) (Note 2)

PARAMETER	SYMBOL	CONDITIONS	MIN	TYP	MAX	UNITS
OUT/OUT						
Output Low Voltage (Open-Drain or Push-Pull)	V_{OL}	$V_{CC} \geq 1.2V$, $I_{SINK} = 90\mu A$, MAX6895/MAX6897/MAX6899 only			0.3	V
		$V_{CC} \geq 2.25V$, $I_{SINK} = 0.5mA$			0.3	
		$V_{CC} \geq 4.5V$, $I_{SINK} = 1mA$			0.4	
Output High Voltage (Push-Pull)	V_{OH}	$V_{CC} \geq 2.25V$, $I_{SOURCE} = 500\mu A$	$0.8 \times V_{CC}$			V
		$V_{CC} \geq 4.5V$, $I_{SOURCE} = 800\mu A$	$0.8 \times V_{CC}$			
Output Open-Drain Leakage Current	I_{LKG}	Output high impedance, $V_{OUT} = 28V$			1	μA
TIMING						
IN to OUT/OUT Propagation Delay	t_{DELAY}	V_{IN} rising	$C_{DELAY} = 0\mu F$	40		μs
			$C_{DELAY} = 0.047\mu F$	190		ms
	t_{DL}	V_{IN} falling		16		μs
Startup Delay (Note 5)				2		ms
ENABLE/ENABLE Minimum Input Pulse Width	t_{PW}		1			μs
ENABLE/ENABLE Glitch Rejection				100		ns
ENABLE/ENABLE to OUT/OUT Delay	t_{OFF}	From device enabled to device disabled		150		ns
ENABLE/ENABLE to OUT/OUT Delay	t_{PROPP}	From device disabled to device enabled (P version)		150		ns
		From device disabled to device enabled (A version)	$C_{DELAY} = 0\mu F$	20		μs
			$C_{DELAY} = 0.047\mu F$	190		ms

Note 2: All devices are production tested at $T_A = +25^{\circ}C$. Limits over temperature are guaranteed by design.

Note 3: When V_{CC} falls below the UVLO threshold, the outputs will deassert (OUT goes low, \overline{OUT} goes high). When V_{CC} falls below 1.2V, the out cannot be determined.

Note 4: Guaranteed by design.

Note 5: During the initial power-up, V_{CC} must exceed 1.5V for at least 2ms before the output is guaranteed to be in the correct state.

Ultra-Small, Adjustable Sequencing/Supervisory Circuits

Typical Operating Characteristics

($V_{CC} = 3.3V$ and $T_A = +25^\circ C$, unless otherwise noted.)

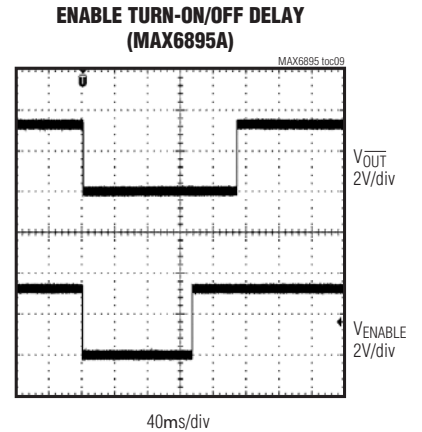
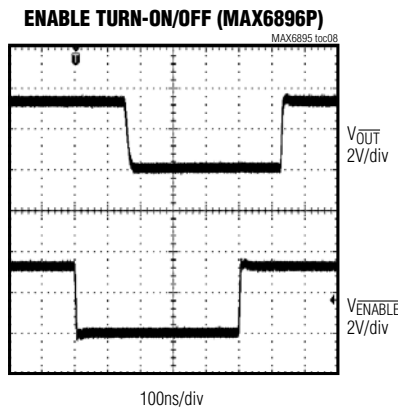
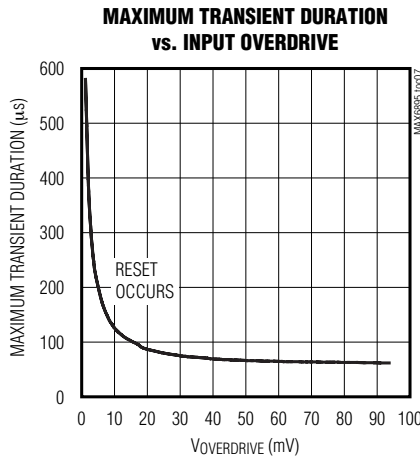
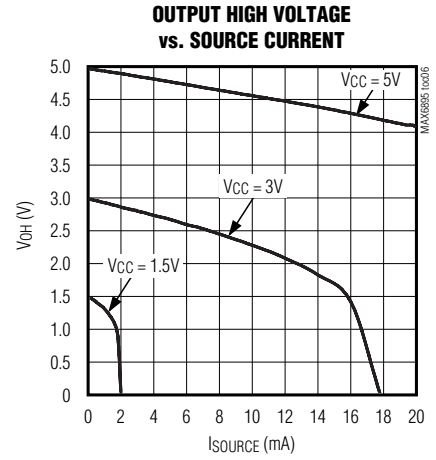
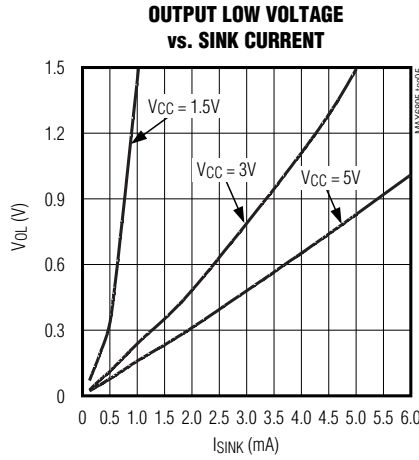
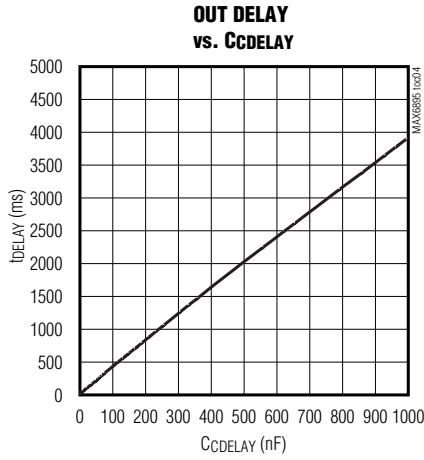
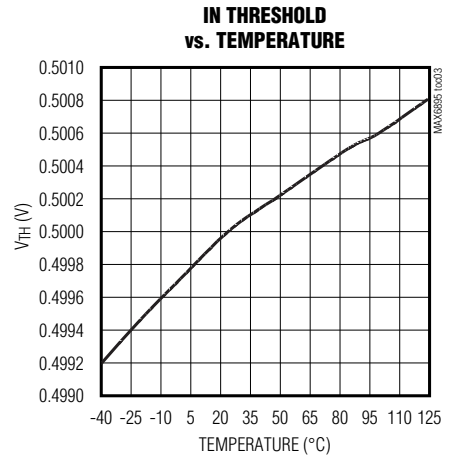
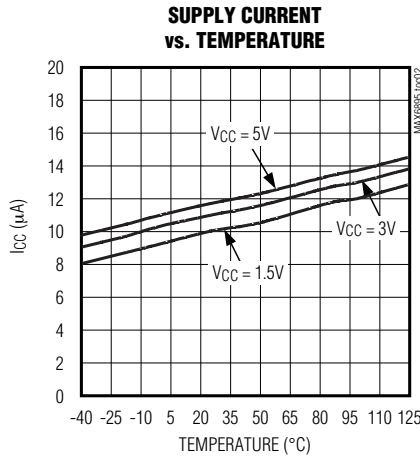
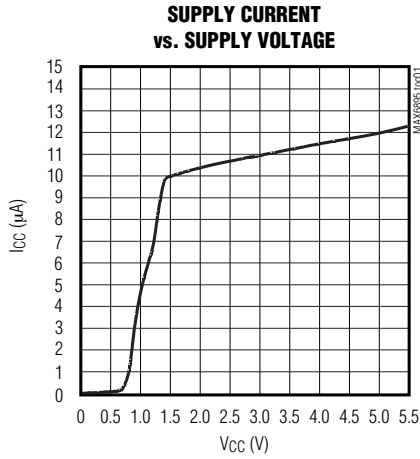

Ultra-Small, Adjustable Sequencing/Supervisory Circuits

Pin Description

MAX6895-MAX6899

PIN						NAME	FUNCTION
MAX6895/ MAX6897		MAX6896/ MAX6898		MAX6899			
μ DFN	THIN SOT23	μ DFN	THIN SOT23	μ DFN	THIN SOT23		
1	1	—	—	—	—	ENABLE	Active-High Logic-Enable Input. Drive ENABLE low to immediately deassert the output to its false state (OUT = low or $\overline{\text{OUT}}$ = high) independent of V_{IN} . With V_{IN} above V_{TH} , drive ENABLE high to assert the output to its true state (OUT = high or $\overline{\text{OUT}}$ = low) after the adjustable delay period (MAX689_A) or a 150ns propagation delay (MAX689_P).
—	—	1	1	1	1	$\overline{\text{ENABLE}}$	Active-Low Logic-Enable Input. Drive $\overline{\text{ENABLE}}$ high to immediately deassert the output to its false state (OUT = low or $\overline{\text{OUT}}$ = high) independent of V_{IN} . With V_{IN} above V_{TH} , drive $\overline{\text{ENABLE}}$ low to assert the output to its true state (OUT = high or $\overline{\text{OUT}}$ = low) after the adjustable delay period (MAX689_A) or a 150ns propagation delay (MAX689_P).
2	2	2	2	2	2	GND	Ground
3	3	3	3	3	3	IN	High-Impedance Monitor Input. Connect IN to an external resistive divider to set the desired monitored threshold. The output changes state when V_{IN} rises above 0.5V and when V_{IN} falls below 0.495V.
4	4	—	—	4	4	OUT	Active-High Sequencer/Monitor Output, Push-Pull (MAX6895/MAX6899) or Open-Drain (MAX6897). OUT is asserted to its true state (OUT = high) when V_{IN} is above V_{TH} and the enable input is in its true state (ENABLE = high or $\overline{\text{ENABLE}}$ = low) for the capacitor-adjusted delay period. OUT is deasserted to its false state (OUT = low) immediately after V_{IN} drops below $V_{\text{TH}} - 5\text{mV}$ or the enable input is in its false state (ENABLE = low or $\overline{\text{ENABLE}}$ = high). The open-drain version requires an external pullup resistor.
—	—	4	4	—	—	$\overline{\text{OUT}}$	Active-Low Sequencer/Monitor Output, Push-Pull (MAX6896) or Open-Drain (MAX6898). OUT is asserted to its true state ($\overline{\text{OUT}}$ = low) when V_{IN} is above V_{TH} and the enable input is in its true state (ENABLE = high or $\overline{\text{ENABLE}}$ = low) after the CDELAY adjusted timeout period. OUT is deasserted to its false state ($\overline{\text{OUT}}$ = high) immediately after V_{IN} drops below $V_{\text{TH}} - 5\text{mV}$ or the enable input is in its false state (ENABLE = low or $\overline{\text{ENABLE}}$ = high). The open-drain version requires an external pullup resistor.
5	6	5	6	5	6	CDELAY	Capacitor-Adjustable Delay. Connect an external capacitor (C_{CDELAY}) from CDELAY to GND to set the IN to OUT (and ENABLE to OUT or $\overline{\text{ENABLE}}$ to OUT for A version devices) delay period. $t_{\text{DELAY}} = (C_{\text{CDELAY}} \times 4.0 \times 10^6) + 40\mu\text{s}$. There is a fixed short delay (40 μs , typ) for the output deasserting when V_{IN} falls below V_{TH} .
6	5	6	5	6	5	VCC	Supply Voltage Input. Connect a 1.5V to 5.5V supply to VCC to power the device. For noisy systems, bypass with a 0.1 μF ceramic capacitor to GND.

Ultra-Small, Adjustable Sequencing/Supervisory Circuits

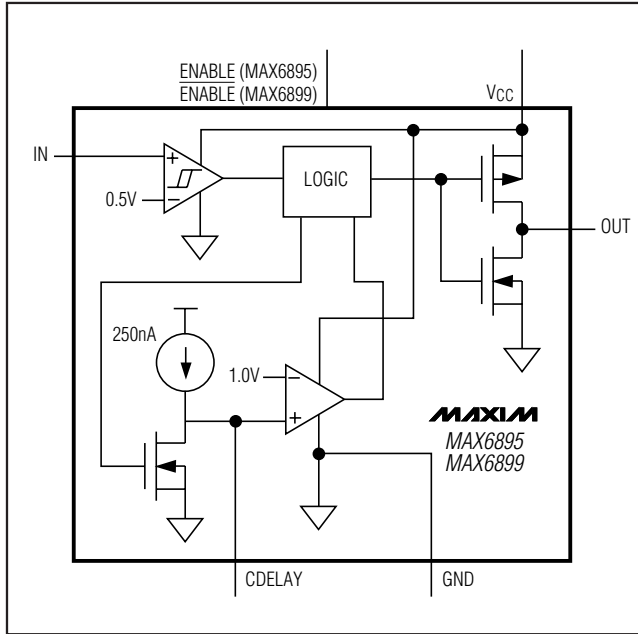

Figure 1. MAX6895/MAX6899 Functional Diagram

Detailed Description

The MAX6895–MAX6899 is a family of ultra-small, low-power, sequencing/supervisory circuits. These devices provide adjustable voltage monitoring for inputs down to 0.5V. They are ideal for use in power-supply sequencing, reset sequencing, and power-switching applications. Multiple devices can be cascaded for complex sequencing applications.

Voltage monitoring is performed through a high-impedance input (IN) with an internally fixed 0.5V threshold. When the voltage at IN falls below 0.5V or when the enable input is deasserted (ENABLE = low or $\overline{\text{ENABLE}}$ = high), the output deasserts (OUT goes low or $\overline{\text{OUT}}$ goes high). When V_{IN} rises above 0.5V and the enable input is asserted (ENABLE = high or $\overline{\text{ENABLE}}$ = low), the output asserts (OUT goes high or $\overline{\text{OUT}}$ goes low) after a capacitor-programmable time delay.

With V_{IN} above 0.5V, the enable input can be used to turn the output on or off. After the enable input is asserted, the output turns on with a capacitor-programmable delay period (A version) or with a 150ns propagation delay (P version). Tables 1, 2, and 3 detail the output state depending on the various input and enable conditions.

Table 1. MAX6895/MAX6897 Output

IN	ENABLE	OUT
$V_{\text{IN}} < V_{\text{TH}}$	Low	Low
$V_{\text{IN}} < V_{\text{TH}}$	High	Low
$V_{\text{IN}} > V_{\text{TH}}$	Low	Low
$V_{\text{IN}} > V_{\text{TH}}$	High	OUT = V_{CC} (MAX6895)
		OUT = high impedance (MAX6897)

Table 2. MAX6896/MAX6898 Output

IN	ENABLE	$\overline{\text{OUT}}$
$V_{\text{IN}} < V_{\text{TH}}$	Low	$\overline{\text{OUT}} = V_{\text{CC}}$ (MAX6896)
		$\overline{\text{OUT}} = \text{high impedance}$ (MAX6898)
$V_{\text{IN}} < V_{\text{TH}}$	High	$\overline{\text{OUT}} = V_{\text{CC}}$ (MAX6896)
		$\overline{\text{OUT}} = \text{high impedance}$ (MAX6898)
$V_{\text{IN}} > V_{\text{TH}}$	Low	Low
$V_{\text{IN}} > V_{\text{TH}}$	High	$\overline{\text{OUT}} = V_{\text{CC}}$ (MAX6896)
		$\overline{\text{OUT}} = \text{high impedance}$ (MAX6898)

Table 3. MAX6899 Output

IN	$\overline{\text{ENABLE}}$	OUT
$V_{\text{IN}} < V_{\text{TH}}$	Low	Low
$V_{\text{IN}} < V_{\text{TH}}$	High	Low
$V_{\text{IN}} > V_{\text{TH}}$	Low	High
$V_{\text{IN}} > V_{\text{TH}}$	High	Low

Supply Input (V_{CC})

The device operates with a V_{CC} supply voltage from 1.5V to 5.5V. To maintain a 1.8% accurate threshold, V_{CC} must be above 1.5V. When V_{CC} falls below the UVLO threshold, the output deasserts. When V_{CC} falls below 1.2V the output state cannot be determined. For noisy systems, connect a 0.1 μF ceramic capacitor from V_{CC} to GND as close to the device as possible. For the push-pull active-high output option, a 100k Ω external pulldown resistor to ground ensures the correct logic state for V_{CC} down to 0.

Ultra-Small, Adjustable Sequencing/Supervisory Circuits

Monitor Input (IN)

Connect the center point of a resistive divider to IN to monitor external voltages (see R1 and R2 of the *Typical Operating Circuit*). IN has a rising threshold of $V_{TH} = 0.5V$ and a falling threshold of $0.495V$ (5mV hysteresis). When V_{IN} rises above V_{TH} and ENABLE is high (or \overline{ENABLE} is low) OUT goes high (\overline{OUT} goes low) after the programmed t_{DELAY} period. When V_{IN} falls below $0.495V$, OUT goes low (\overline{OUT} goes high) after a $16\mu s$ delay. IN has a maximum input current of 15nA so large-value resistors are permitted without adding significant error to the resistive divider.

Adjustable Delay (CDELAY)

When V_{IN} rises above V_{TH} with ENABLE high (\overline{ENABLE} low), the internal 250nA current source begins charging an external capacitor connected from CDELAY to GND. When the voltage at CDELAY reaches 1V, the output

asserts (OUT goes high or \overline{OUT} goes low). When the output asserts, C_{DELAY} is immediately discharged. Adjust the delay (t_{DELAY}) from when V_{IN} rises above V_{TH} (with ENABLE high or \overline{ENABLE} low) to OUT going high (OUT going low) according to the equation:

$$t_{DELAY} = C_{DELAY} \times 4.0 \times 10^6 + 40\mu s$$

where C_{DELAY} is the external capacitor from CDELAY to GND.

For adjustable delay devices (A version), when $V_{IN} > 0.5V$ and ENABLE goes from low to high (\overline{ENABLE} goes from high to low) the output asserts after a t_{DELAY} period. For nonadjustable delay devices (P version) there is a $1\mu s$ propagation delay from when the enable input is asserted to when the output asserts. Figures 2 through 5 show the timing diagrams for the adjustable and fixed delay versions, respectively.

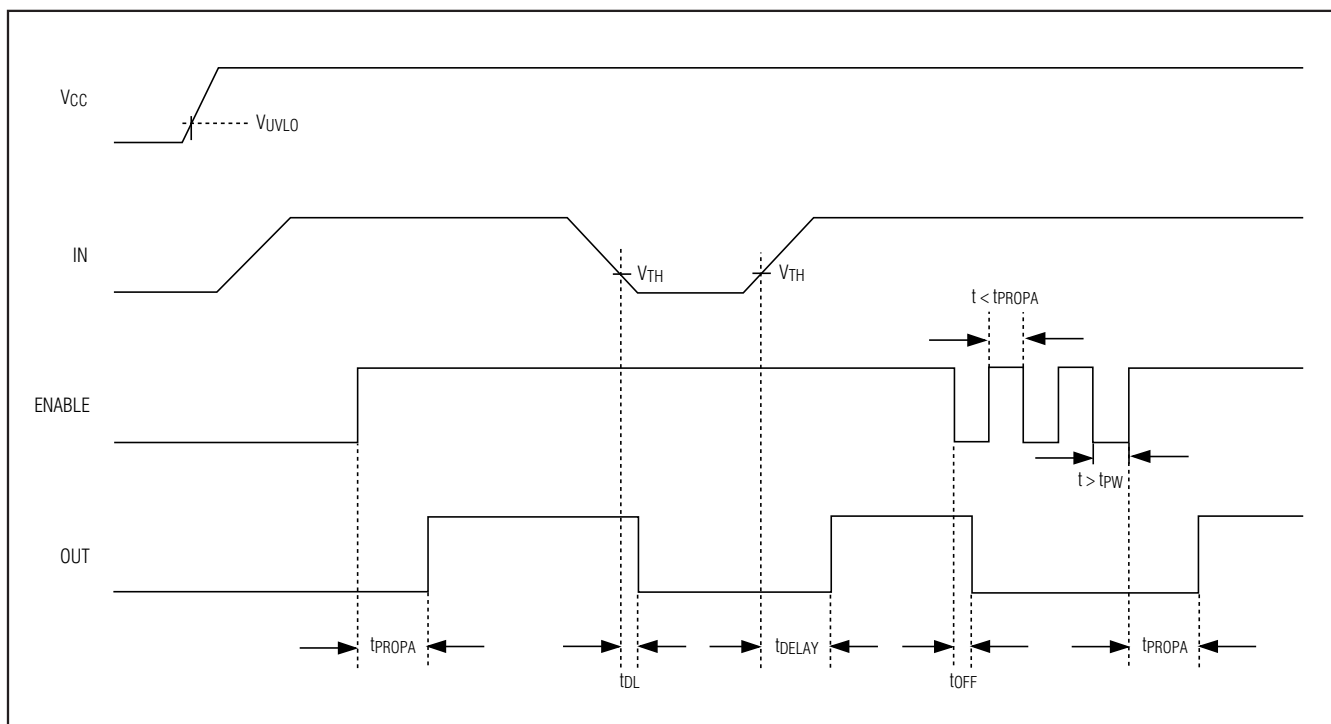

Figure 2. MAX6895A/MAX6897A Timing Diagram

Ultra-Small, Adjustable Sequencing/Supervisory Circuits

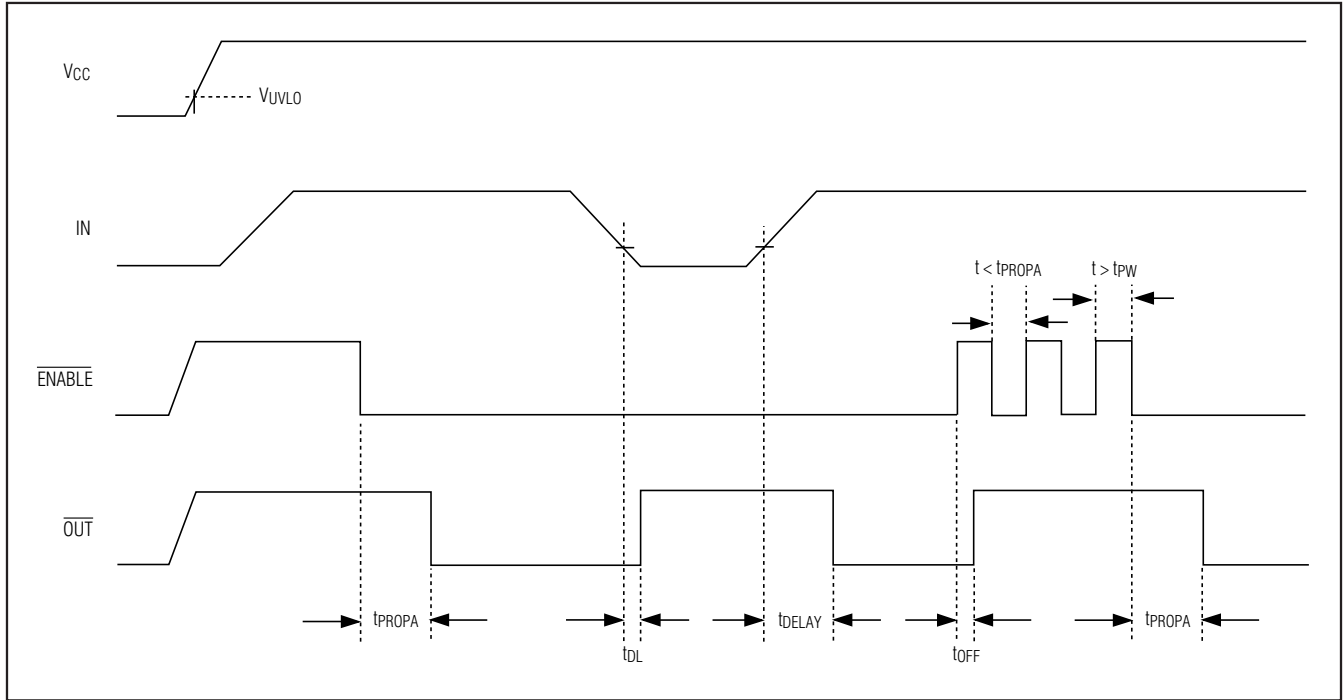

Figure 3. MAX6896A/MAX6898A Timing Diagram

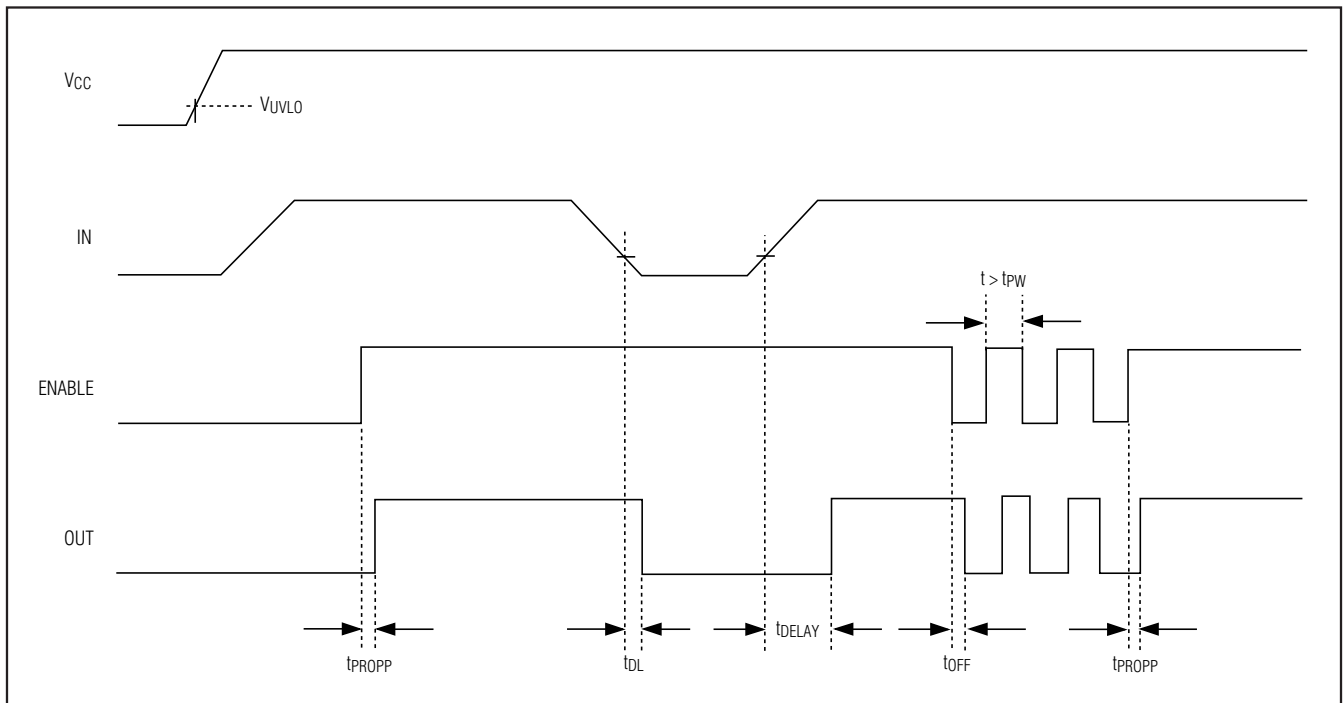

Figure 4. MAX6895P/MAX6897P Timing Diagram

Ultra-Small, Adjustable Sequencing/Supervisory Circuits

MAX6895-MAX6899

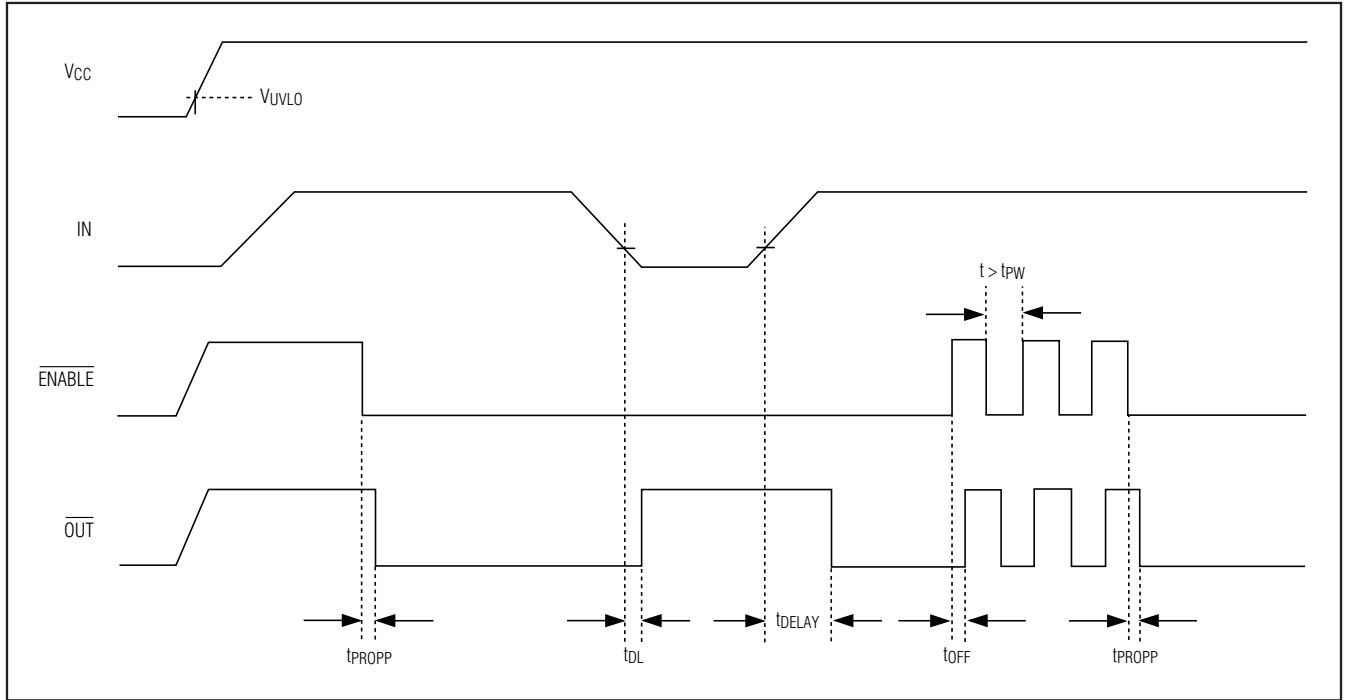

Figure 5. MAX6896P/MAX6898P Timing Diagram

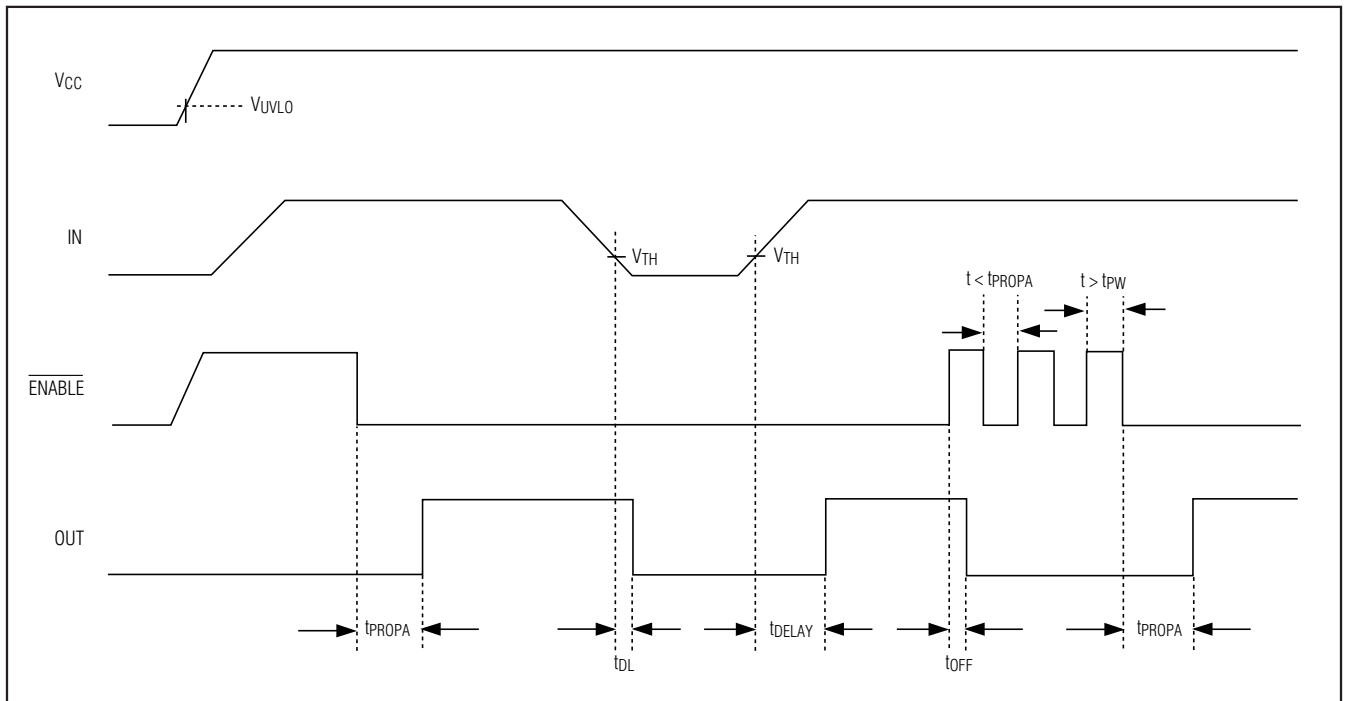

Figure 6. MAX6899A Timing Diagram

Ultra-Small, Adjustable Sequencing/Supervisory Circuits

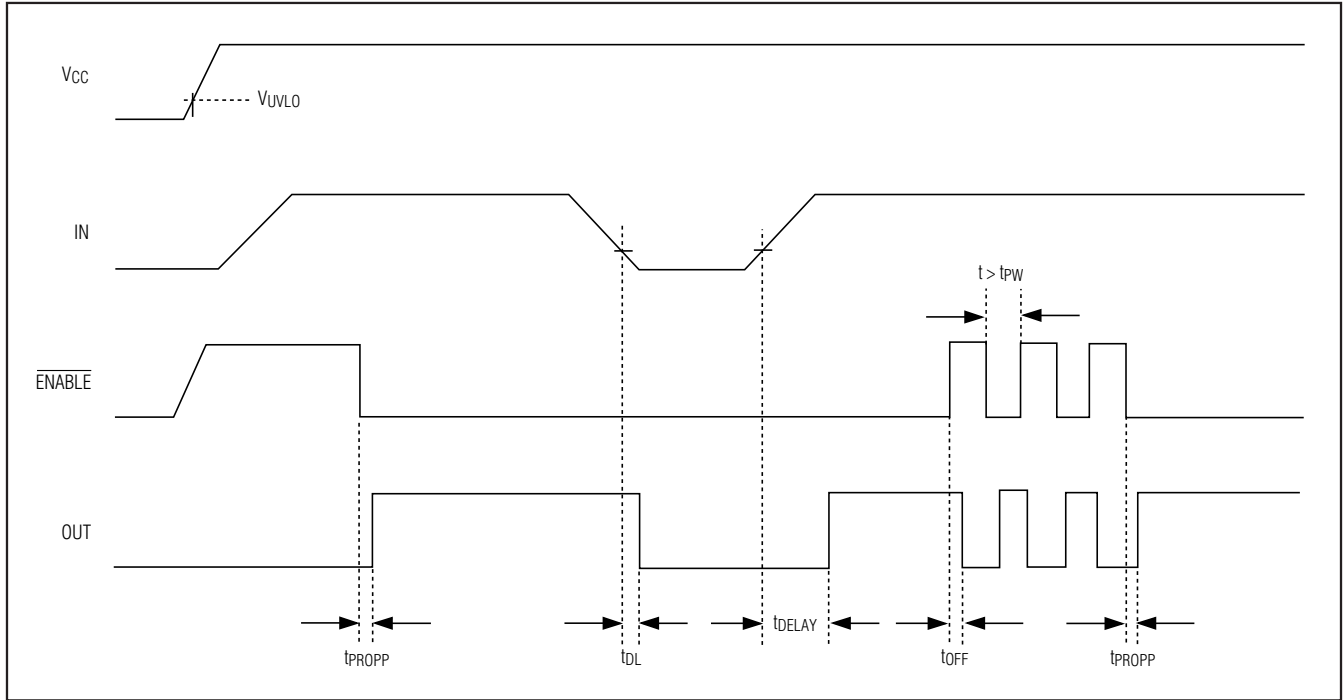

Figure 7. MAX6899P Timing Diagram

Enable Input (ENABLE or $\overline{\text{ENABLE}}$)

The MAX6895/MAX6897 offer an active-high enable input (ENABLE), while the MAX6896/MAX6898/MAX6899 offer an active-low enable input ($\overline{\text{ENABLE}}$). With V_{IN} above V_{TH} , drive ENABLE high ($\overline{\text{ENABLE}}$ low) to force OUT high ($\overline{\text{OUT}}$ low) after the adjustable delay time (A versions). For P version devices, when $V_{IN} > 0.5V$ and enable is asserted, the output asserts after typically 150ns.

The enable input has logic-high and logic-low voltage thresholds of 1.4V and 0.4V, respectively. For both versions, when $V_{IN} > 0.5V$, drive $\overline{\text{ENABLE}}$ low ($\overline{\text{ENABLE}}$ high) to force OUT low ($\overline{\text{OUT}}$ high) within 150ns typ.

Output (OUT or $\overline{\text{OUT}}$)

The MAX6895/MAX6899 offer an active-high, push-pull output (OUT), and the MAX6896 offers an active-low push-pull output ($\overline{\text{OUT}}$). The MAX6897 offers an active-high open-drain output (OUT), and the MAX6898 offers an active-low open-drain output ($\overline{\text{OUT}}$).

Push-pull output devices are referenced to V_{CC} . Open-drain outputs can be pulled up to 28V.

Applications Information

Input Threshold

The MAX6895–MAX6899 monitor the voltage on IN with an external resistive divider (see R1 and R2 in the *Typical Operating Circuit*). Connect R1 and R2 as close to IN as possible. R1 and R2 can have very high values to minimize current consumption due to low IN leakage currents ($\pm 15nA$ max). Set R2 to some conveniently high value (1M Ω , for example) and calculate R1 based on the desired monitored voltage using the following formula:

$$R1 = R2 \times \left[\frac{V_{\text{MONITOR}}}{V_{IN}} - 1 \right]$$

where V_{MONITOR} is the desired monitored voltage and V_{IN} is the detector input threshold (0.5V).

Ultra-Small, Adjustable Sequencing/Supervisory Circuits

Pullup Resistor Values (MAX6897/MAX6898)

The exact value of the pullup resistors for the open-drain outputs is not critical, but some consideration should be made to ensure the proper logic levels when the device is sinking current. For example, if $V_{CC} = 2.25V$ and the pullup voltage is 28V, you would try to keep the sink current less than 0.5mA as shown in the *Electrical Characteristics* table. As a result, the pullup resistor should be greater than 56k Ω . For a 12V pullup, the resistor should be larger than 24k Ω . It should be noted that the ability to sink current is dependent on the V_{CC} supply voltage.

Typical Application Circuits

Figures 8, 9, 10 show typical applications for the MAX6895–MAX6899. Figure 8 shows the MAX6895

used with a p-channel MOSFET in an overvoltage protection circuit. Figure 9 shows the MAX6895 in a low-voltage sequencing application using an n-channel MOSFET. Figure 10 shows the MAX6895 used in a multiple-output sequencing application.

Using an n-Channel Device for Sequencing

In higher power applications, using an n-channel device reduces the loss across the MOSFETs as it offers a lower drain-to-source on-resistance. However, an n-channel MOSFET requires a sufficient V_{GS} voltage to fully enhance it for a low R_{DS_ON} . The application in Figure 9 shows the MAX6895 in a switch sequencing application using an n-channel MOSFET.

Similarly, if a higher voltage is present in the system, the open-drain version can be used in the same manner.

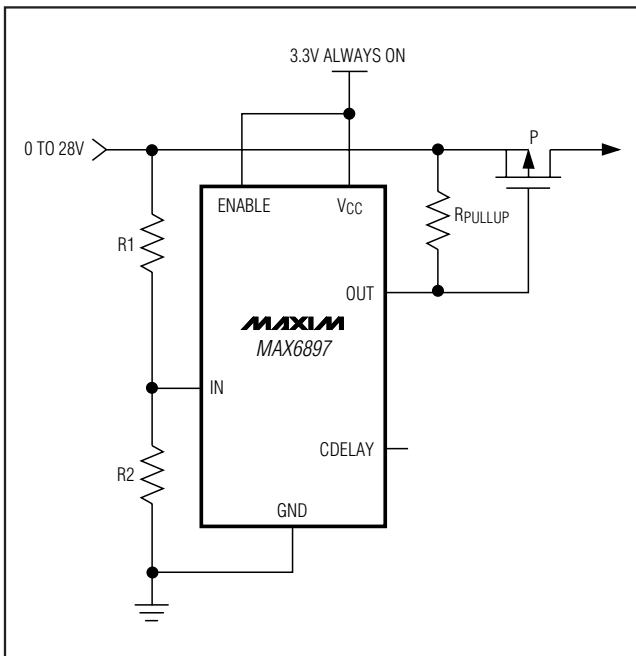

Figure 8. Overvoltage Protection

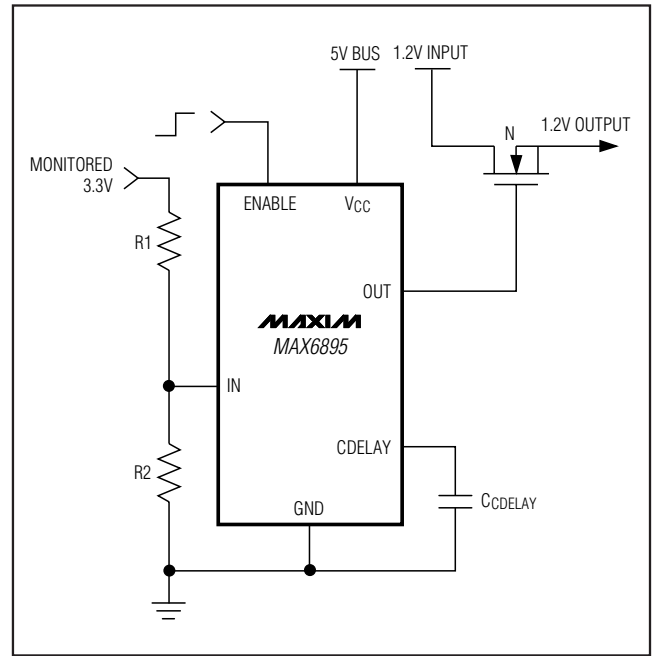

Figure 9. Low-Voltage Sequencing Using an n-Channel MOSFET

Ultra-Small, Adjustable Sequencing/Supervisory Circuits

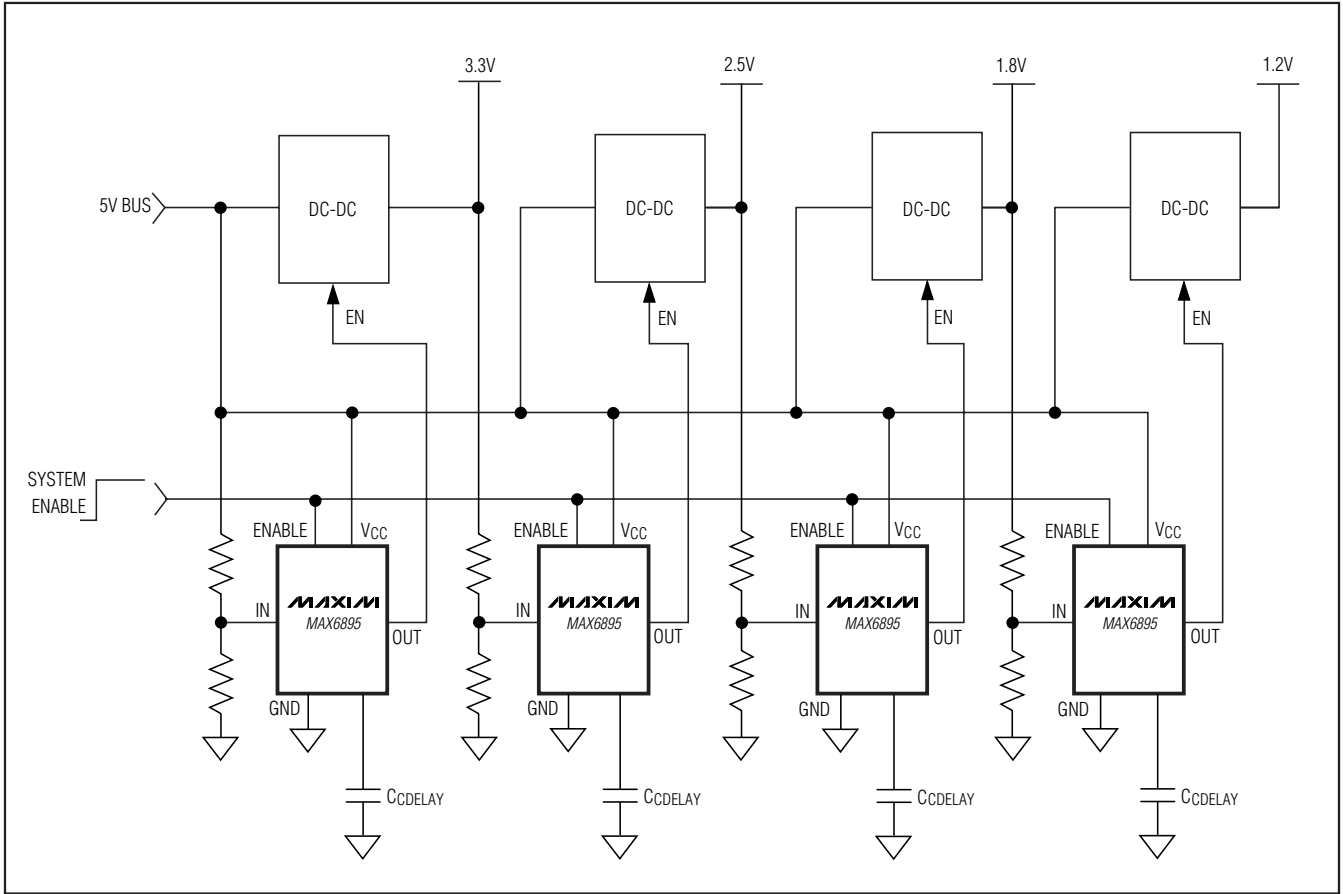

Figure 10. Multiple-Output Sequencing

Ultra-Small, Adjustable Sequencing/Supervisory Circuits

Selector Guide

MAX6895-MAX6899

PART	ENABLE INPUT	OUTPUT	INPUT (IN) DELAY	ENABLE DELAY
MAX6895AALT+T	Active-High	Active-High, Push-Pull	Capacitor Adjustable	Capacitor Adjustable
MAX6895AAZT+T	Active-High	Active-High, Push-Pull	Capacitor Adjustable	Capacitor Adjustable
MAX6895PALT+T	Active-High	Active-High, Push-Pull	Capacitor Adjustable	150ns Delay
MAX6895PAZT+T	Active-High	Active-High, Push-Pull	Capacitor Adjustable	150ns Delay
MAX6896AALT+T	Active-Low	Active-Low, Push-Pull	Capacitor Adjustable	Capacitor Adjustable
MAX6896AAZT+T	Active-Low	Active-Low, Push-Pull	Capacitor Adjustable	Capacitor Adjustable
MAX6896PALT+T	Active-Low	Active-Low, Push-Pull	Capacitor Adjustable	150ns Delay
MAX6896PAZT+T	Active-Low	Active-Low, Push-Pull	Capacitor Adjustable	150ns Delay
MAX6897AALT+T	Active-High	Active-High, Open-Drain	Capacitor Adjustable	Capacitor Adjustable
MAX6897AAZT+T	Active-High	Active-High, Open-Drain	Capacitor Adjustable	Capacitor Adjustable
MAX6897PALT+T	Active-High	Active-High, Open-Drain	Capacitor Adjustable	150ns Delay
MAX6897PAZT+T	Active-High	Active-High, Open-Drain	Capacitor Adjustable	150ns Delay
MAX6898AALT+T	Active-Low	Active-Low, Open-Drain	Capacitor Adjustable	Capacitor Adjustable
MAX6898AAZT+T	Active-Low	Active-Low, Open-Drain	Capacitor Adjustable	Capacitor Adjustable
MAX6898PALT+T	Active-Low	Active-Low, Open-Drain	Capacitor Adjustable	150ns Delay
MAX6898PAZT+T	Active-Low	Active-Low, Open-Drain	Capacitor Adjustable	150ns Delay
MAX6899AALT+T	Active-Low	Active-High, Push-Pull	Capacitor Adjustable	Capacitor Adjustable
MAX6899AAZT+T	Active-Low	Active-High, Push-Pull	Capacitor Adjustable	Capacitor Adjustable
MAX6899PALT+T	Active-Low	Active-High, Push-Pull	Capacitor Adjustable	150ns Delay
MAX6899PAZT+T	Active-Low	Active-High, Push-Pull	Capacitor Adjustable	150ns Delay

Ordering Information (continued)

PART	PIN-PACKAGE	TOP MARK
MAX6897AALT+	6 μ DFN	+BA
MAX6897AAZT+	6 Thin SOT23	+AADQ
MAX6897PALT+T	6 μ DFN	+BB
MAX6897PAZT+	6 Thin SOT23	+AADR
MAX6898AALT+	6 μ DFN	+BD
MAX6898AAZT+	6 Thin SOT23	+AADS
MAX6898PALT+T	6 μ DFN	+BC
MAX6898PAZT+	6 Thin SOT23	+AADT
MAX6899AALT+	6 μ DFN	+LO
MAX6899AAZT+	6 Thin SOT23	+AADM
MAX6899PALT+T	6 μ DFN	+LP
MAX6899PAZT+	6 Thin SOT23	+AADN

Note: All devices are specified over the -40°C to $+125^{\circ}\text{C}$ operating temperature range.

+Denotes a lead(Pb)-free/RoHS-compliant package.

T = Tape and reel.

Typical Operating Circuit

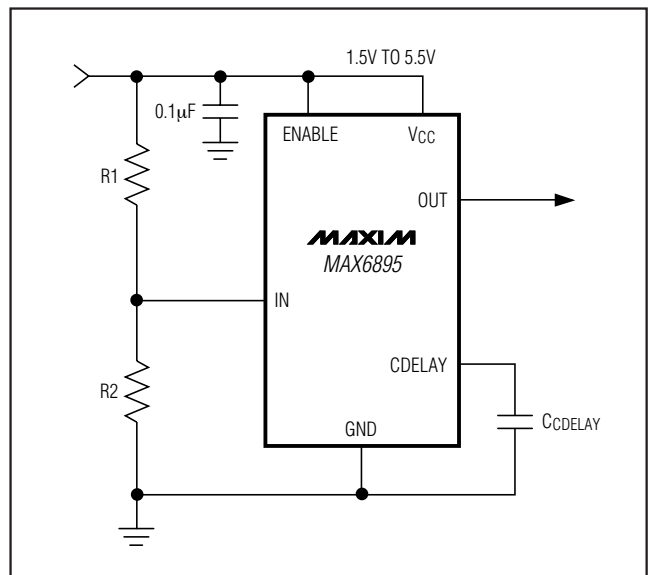

Ultra-Small, Adjustable Sequencing/Supervisory Circuits

Pin Configurations (continued)

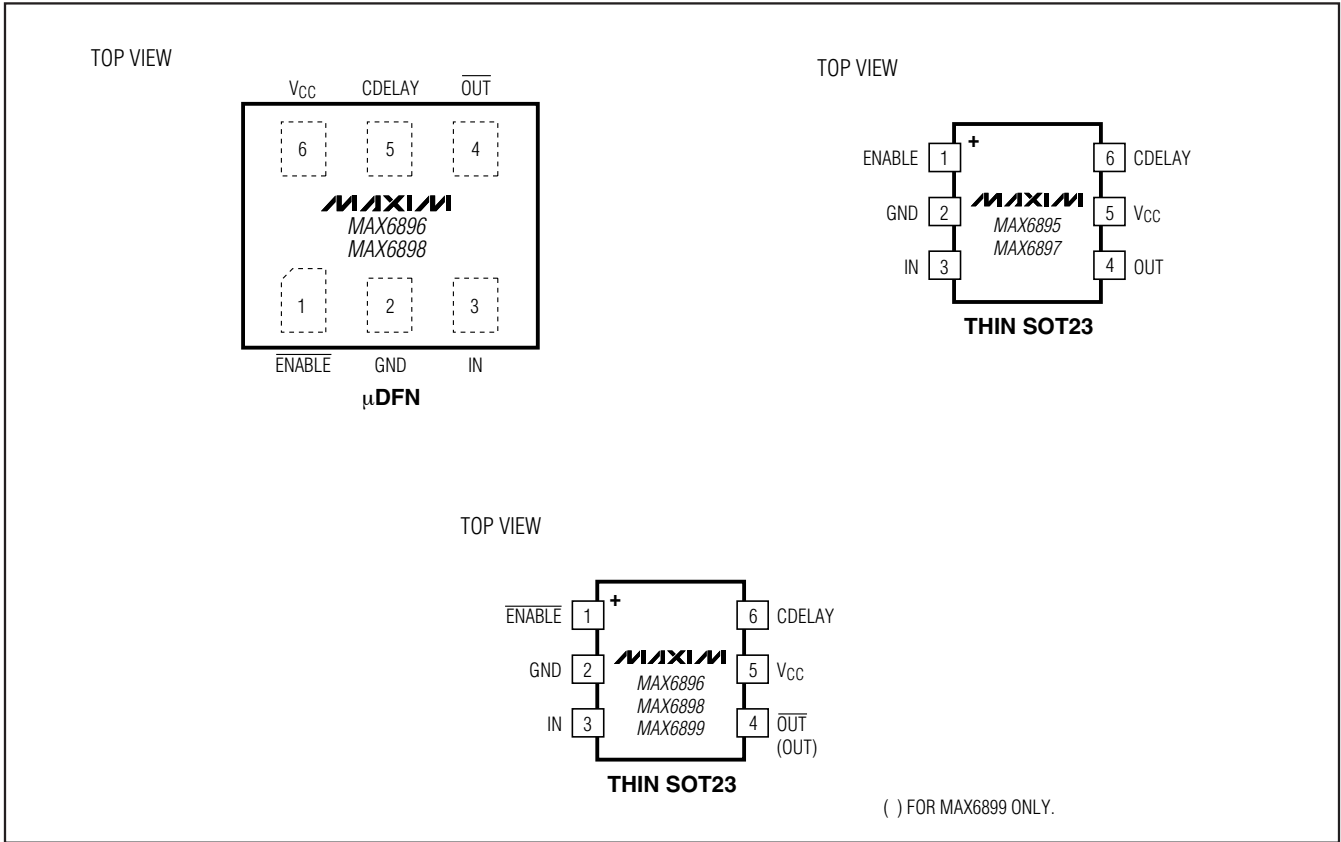

Chip Information

PROCESS: BICMOS

Package Information

For the latest package outline information and land patterns (footprints), go to www.maxim-ic.com/packages. Note that a "+", "#", or "-" in the package code indicates RoHS status only. Package drawings may show a different suffix character, but the drawing pertains to the package regardless of RoHS status.

PACKAGE TYPE	PACKAGE CODE	OUTLINE NO.	LAND PATTERN NO.
6 μ DFN	L611+1	21-0147	90-0080
6 Thin SOT23	Z6+1	21-0114	90-0242

Ultra-Small, Adjustable Sequencing/Supervisory Circuits

Revision History

REVISION NUMBER	REVISION DATE	DESCRIPTION	PAGES CHANGED
5	10/07	—	1, 13, 18
6	11/09	Corrected <i>Absolute Maximum Ratings</i> and made style corrections to <i>Electrical Characteristics</i> and TOC8 and TOC9	2-5
7	7/10	Revised Figures 3, 4, and 6.	7-9
8	7/11	Added automotive packages for MAX6896A and MAX6896P. Added top mark to MAX6896AAZT/V+1 in <i>Ordering Information</i> .	1

MAX6895-MAX6899

Maxim cannot assume responsibility for use of any circuitry other than circuitry entirely embodied in a Maxim product. No circuit patent licenses are implied. Maxim reserves the right to change the circuitry and specifications without notice at any time. The parametric values (min and max limits) shown in the Electrical Characteristics table are guaranteed. Other parametric values quoted in this data sheet are provided for guidance.

Maxim Integrated Products, 120 San Gabriel Drive, Sunnyvale, CA 94086 408-737-7600 _____ 15