



Dual-/Triple-Voltage, Power-Supply Trackers/Sequencers/Supervisors

General Description

The MAX6877/MAX6878/MAX6879 multivoltage power trackers/sequencers/supervisors monitor up to three system voltages and provide proper power-up and power-down control for systems requiring voltage tracking or sequencing. These devices ensure controlled voltage tracking within a specified range or sequencing in the proper order as system power supplies are enabled. The MAX6877/MAX6878/MAX6879 generate all required voltages and timing to control up to three external n-channel pass FETs for the OUT1/OUT2/OUT3 supply voltages (see the *Selector Guide* for different features of each device).

The MAX6877/MAX6878/MAX6879 feature adjustable undervoltage thresholds for each input supply. When all the voltages are above these adjustable thresholds, the devices turn on the external n-channel MOSFETs to either sequence or track the voltages to the system. During voltage-tracking mode, the voltage at the GATE of each MOSFET is increased to slowly bring up all supplies at a controlled slew rate. The MAX6877/MAX6878/MAX6879 feature an autoretry or latch-off mode with capacitor-adjusted timing.

These devices also provide a controlled power-down (tracking mode) when the system shuts off in an orderly manner. When an unexpected fault occurs, the outputs are all pulled down simultaneously with an internal 100Ω pulldown to help discharge capacitive loads at the MOSFET's source. The MAX6877/MAX6878/MAX6879 feature independent internal charge pumps to fully enhance the external FETs for low-voltage drop at highpass current. The MAX6877 and MAX6878 also feature a power-good output with a selectable timeout period that can be used for system reset.

The MAX6877/MAX6878/MAX6879 are available in small 4mm x 4mm 24-pin and 16-pin thin QFN packages and are fully specified over the -40°C to +85°C extended operating temperature range.

Applications

Multivoltage Systems
Networking Systems
Telecom
Storage Equipment
Servers/Workstations

Selector Guide appears at end of data sheet.

Features

- ◆ Pin-Selectable Tracking or Sequencing Control for Up to Three Supply Voltages
- ◆ Capacitor-Adjustable Power-Up/Down Tracking Slew Rate
- ◆ Capacitor-Adjustable Power-Up Sequencing Delay
- ◆ Internal Charge Pumps to Enhance External n-Channel FETs
- ◆ Capacitor-Adjustable Timeout Period Power-Good Output (MAX6877/MAX6878)
- ◆ Adjustable Undervoltage Lockout or Logic-Enable Input
- ◆ Internal 100Ω Pulldown for Each Output to Discharge Capacitive Load Quickly
- ◆ 0.5V to 5.5V Nominal IN₁/OUT₁ Range
- ◆ 2.7V to 5.5V Operating Voltage Range
- ◆ Immune to Short Voltage Transients
- ◆ Small 4mm x 4mm 24-Pin or 16-Pin Thin QFN Packages

Ordering Information

PART	TEMP RANGE	PIN-PACKAGE	PKG CODE
MAX6877ETG+	-40°C to +85°C	24 Thin QFN	T2444-4
MAX6877ETG	-40°C to +85°C	24 Thin QFN	T2444-4

Ordering Information continued at end of data sheet.

+Denotes lead-free package.

Pin Configurations

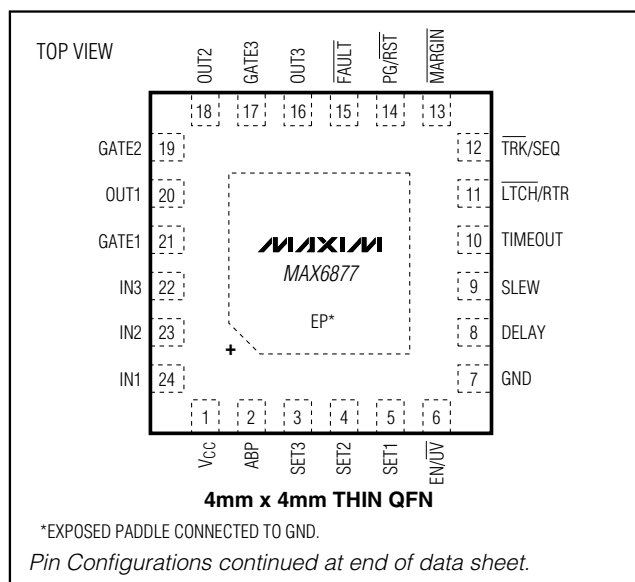

MAX6877/MAX6878/MAX6879



Dual-/Triple-Voltage, Power-Supply Trackers/Sequencers/Supervisors

ABSOLUTE MAXIMUM RATINGS

(All voltages referenced to GND, unless otherwise noted.)

IN1, IN2, IN3, V _{CC}	-0.3V to +6V	Input/Output Current (all pins except OUT_ and GND)	±20mA
ABP	-0.3V to the highest of V _{IN1} - V _{IN3} or V _{CC}	Continuous Power Dissipation (T _A = +70°C)	
SET1, SET2, SET3	-0.3V to +6V	16-Pin 4mm x 4mm Thin QFN	
GATE1, GATE2, GATE3	-0.3V to +12V	(derate 16.9mW/°C above +70°C)	1349mW
OUT1, OUT2, OUT3	-0.3V to +6V	24-Pin 4mm x 4mm Thin QFN	
LTCH/RTR, TRK/SEQ, MARGIN	-0.3V to +6V	(derate 20.8mW/°C above +70°C)	1667mW
FAULT, PG/RST, EN/UV	-0.3V to +6V	Operating Temperature Range	-40°C to +85°C
DELAY, SLEW, TIMEOUT	-0.3V to +6V	Storage Temperature Range	-65°C to +150°C
OUT_ Current	±50mA	Maximum Junction Temperature	+150°C
GND Current	±50mA	Lead Temperature (soldering, 10s)	+300°C

Stresses beyond those listed under "Absolute Maximum Ratings" may cause permanent damage to the device. These are stress ratings only, and functional operation of the device at these or any other conditions beyond those indicated in the operational sections of the specifications is not implied. Exposure to absolute maximum rating conditions for extended periods may affect device reliability.

ELECTRICAL CHARACTERISTICS

(V_{CC}, IN1, IN2, or IN3 = +2.7V to +5.5V, EN/UV = MARGIN = ABP, T_A = -40°C to +85°C, unless otherwise specified. Typical values are at T_A = +25°C, unless otherwise noted.) (Note 1)

PARAMETER	SYMBOL	CONDITIONS	MIN	TYP	MAX	UNITS
Operating Voltage Range	V _{CC}	Voltage on ABP (the highest of V _{CC} or IN_) to ensure that PG/RST and FAULT are valid and GATE_ = 0V	1.4			V
		Voltage on ABP (the highest of V _{CC} or IN_) to ensure the device is fully operational	2.7		5.5	
Supply Current	I _{CC}	V _{CC} = 5.5V, IN1 = IN2 = IN3 = 3.3V, no load		1.1	1.8	mA
SET_ Threshold Range	V _{TH}	SET_ falling, T _A = +25°C	0.4925	0.5	0.5075	V
		SET_ falling, T _A = -40°C to +85°C	0.4875	0.5	0.5125	
SET_ Threshold Hysteresis	V _{TH_HYS}	SET_ rising		0.5		%
SET_ Input Current	I _{SET}	SET_ = 0.5V	-100		+100	nA
EN/UV Input Voltage	V _{EN_R}	Input rising		1.286		V
	V _{EN_F}	Input falling	1.22	1.25	1.28	
EN/UV Input Current	I _{EN}		-5		+5	µA
EN/UV Input Pulse Width	t _{EN}	EN/UV falling, 100mV overdrive	7			µs
DELAY, TIMEOUT Output Current	I _D	(Notes 2, 3)	2.12	2.5	2.88	µA
DELAY, TIMEOUT Threshold Voltage		V _{CC} = 3.3V		1.25		V
SLEW Output Current (Note 4)	I _S		22.5	25	27.5	µA
Track/Sequence Slew-Rate Timebase Accuracy	SR	C _{SLEW} = 200pF (Note 4)	-15		+15	%
Timebase/CSLEW Ratio		100pF < C _{SLEW} < 1nF (Note 4)		104		kΩ
Slew-Rate Accuracy during Power-Up and Power-Down		C _{SLEW} = 200pF, ABP = 5.5V (Note 4)	-50		+50	%
Power-Good Threshold	V _{TH_PG}	V _{OUT_} falling	91.5	92.5	93.5	%

Dual-/Triple-Voltage, Power-Supply Trackers/Sequencers/Supervisors

MAX6877/MAX6878/MAX6879

ELECTRICAL CHARACTERISTICS (continued)

(V_{CC}, IN1, IN2, or IN3 = +2.7V to +5.5V, EN/ \overline{UV} = \overline{MARGIN} = ABP, T_A = -40°C to +85°C, unless otherwise specified. Typical values are at T_A = +25°C, unless otherwise noted.) (Note 1)

PARAMETER	SYMBOL	CONDITIONS	MIN	TYP	MAX	UNITS
Power-Good Threshold Hysteresis	V _{HYS_PG}	V _{OUT_} rising		0.5		%
GATE_ Output High	V _{GOH}	I _{SOURCE} = 0.5μA	IN_ + 4.2	IN_ + 5.0	IN_ + 5.8	V
GATE_ Pullup Current	I _{GUP}	During power-up and power-down, V _{GATE_} = 1V	2.5	4		μA
GATE_ Pulldown Current	I _{GD}	During power-up and power-down, V _{GATE_} = 5V	2.5	4		μA
	I _{GDS}	When disabled, V _{GATE_} = 5V, V _{IN_} ≥ 2.7V		9.5		mA
		When disabled, V _{GATE_} = 5V, V _{IN_} ≥ 4V		20		
SET_ to GATE_ Delay	t _{D-GATE}	SET falling, 25mV overdrive		6		μs
\overline{FAULT} , PG/ \overline{RST} Output Low	V _{OL}	V _{IN_} ≥ 2.7V, I _{SINK} = 1mA, output asserted			0.3	V
		V _{IN_} ≥ 4.0V, I _{SINK} = 4mA, output asserted			0.4	
Tracking Differential Voltage Stop Ramp	V _{TRK}	Differential between each of the OUT_ and the ramp voltage during power-up and power-down, Figure 10 (Note 5)	75	125	180	mV
Tracking Differential Fault Voltage	V _{TRK_F}	Differential between each of the OUT_ and the ramp voltage, Figure 10 (Note 5)	200	250	310	mV
Tracking Differential Voltage Hysteresis				20		%
Power-Low Threshold	V _{TH_PL}	OUT_ falling	125	142	170	mV
Power-Low Hysteresis	V _{TH_PLHYS}	OUT_ rising		10		mV
OUT to GND Pulldown Impedance		V _{ABP} > 2.7V (Note 6)		100		Ω
\overline{MARGIN} , $\overline{TRK/SEQ}$, $\overline{LTCH/RTR}$ Pullup Current	I _{IN}		7	10	13	μA
\overline{MARGIN} , $\overline{TRK/SEQ}$, $\overline{LTCH/RTR}$ Input Voltage	V _{IL}				0.8	V
	V _{IH}		2.0			
\overline{MARGIN} , $\overline{TRK/SEQ}$, $\overline{LTCH/RTR}$ Glitch Rejection				100		ns

Note 1: Specifications guaranteed for the stated global conditions. 100% production tested at T_A = +25°C and T_A = +85°C. Specifications at T_A = -40°C to +85°C are guaranteed by design. These devices meet the parameters specified when at least one of V_{CC}, IN1/IN2/IN3 is between 2.7V to 5.5V, while the remaining IN1/IN2/IN3 are between 0 and 5.5V.

Note 2: A current I_D = 2.5μA ±15% is generated internally and is used to set the DELAY and TIMEOUT periods and used as a reference for t_{DELAY} and t_{TIMEOUT}.

Note 3: The total DELAY is t_{DELAY} = 200ms + (500kΩ × C_{DELAY}). Leave DELAY unconnected for 200μs delay. The total TIMEOUT is t_{TIMEOUT} = 200μs + (500kΩ × C_{TIMEOUT}). Leave TIMEOUT unconnected for 200μs timeout.

Note 4: A current I_S = 25μA ±10% is generated internally and used as a reference for t_{FAULT}, t_{RETRY}, and slew rate.

Note 5: During power-up, only the condition OUT_ < ramp - V_{TRK} is checked in order to stop the ramp. However, both conditions OUT_ < ramp - V_{TRK_F} and OUT_ > ramp + V_{TRK_F} cause a fault. During power-down, only the condition OUT > ramp + V_{TRK} is checked in order to stop the ramp. However, both conditions OUT_ < ramp - V_{TRK_F} and OUT_ > ramp + V_{TRK_F} cause a fault (see Figure 10). Therefore, if OUT1, OUT2, and OUT3 (during power-up tracking and power-down) differ by more than 2 × V_{TRK_F}, a fault condition is asserted.

Note 6: A 100Ω pulldown to GND activated by a fault condition. See the *Internal Pulldown* section.

Dual-/Triple-Voltage, Power-Supply Trackers/Sequencers/Supervisors

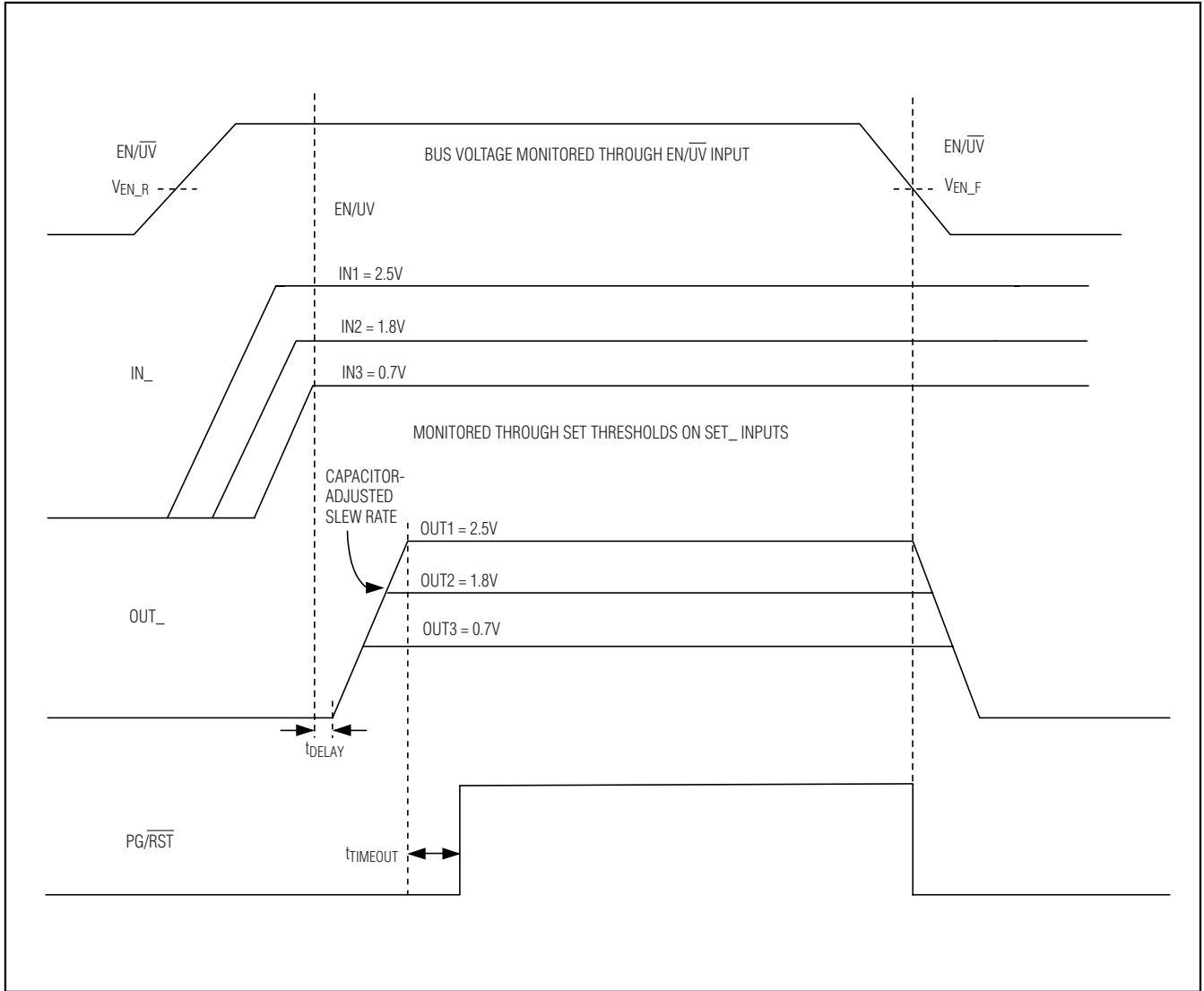

Figure 1. Tracking Timing Diagram in Normal Mode

Dual-/Triple-Voltage, Power-Supply Trackers/Sequencers/Supervisors

MAX6877/MAX6878/MAX6879

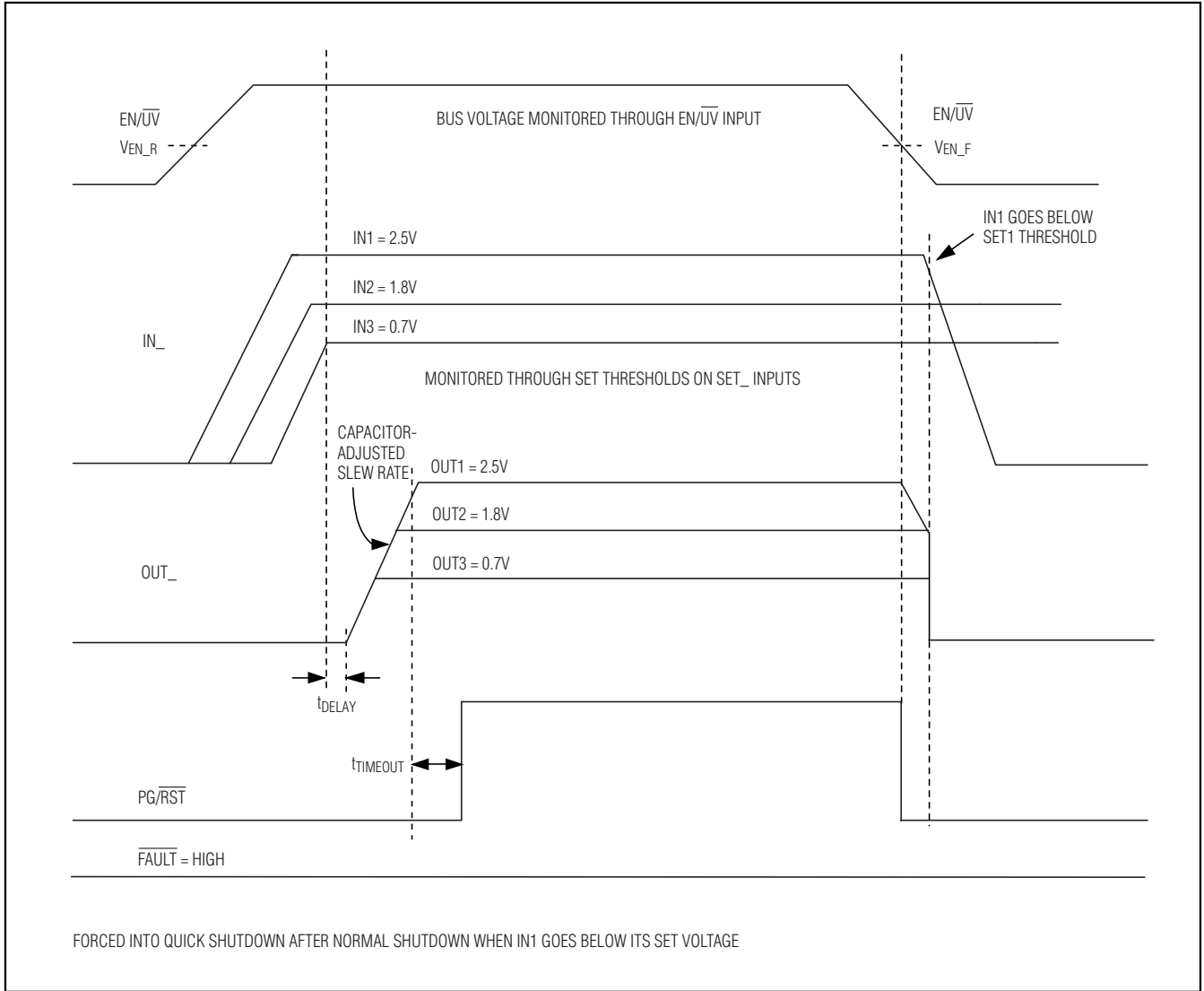

Figure 2. Tracking in Fast Shutdown Mode

Dual-/Triple-Voltage, Power-Supply Trackers/Sequencers/Supervisors

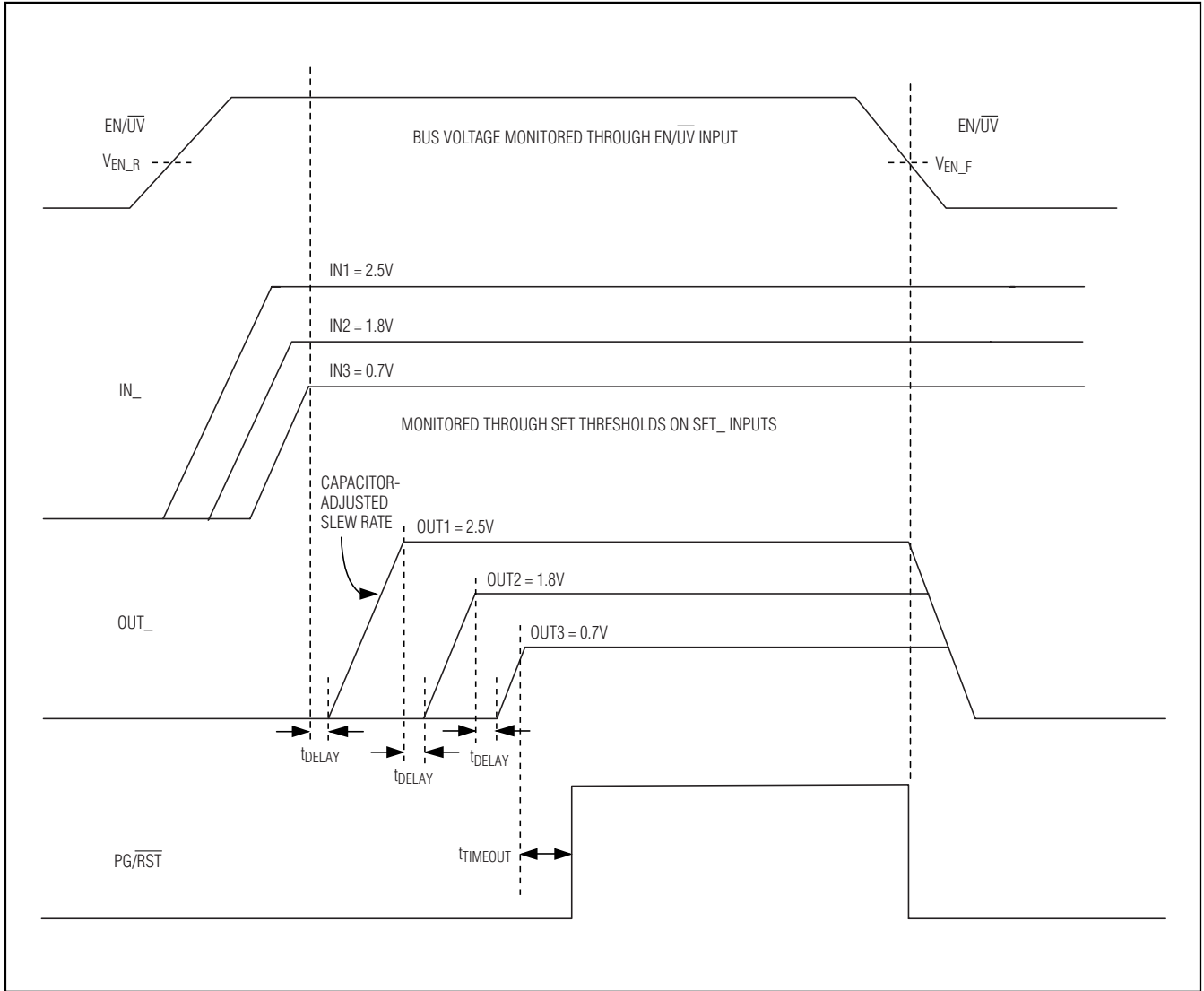

Figure 3. Sequencing in Normal Mode

Dual-/Triple-Voltage, Power-Supply Trackers/Sequencers/Supervisors

MAX6877/MAX6878/MAX6879

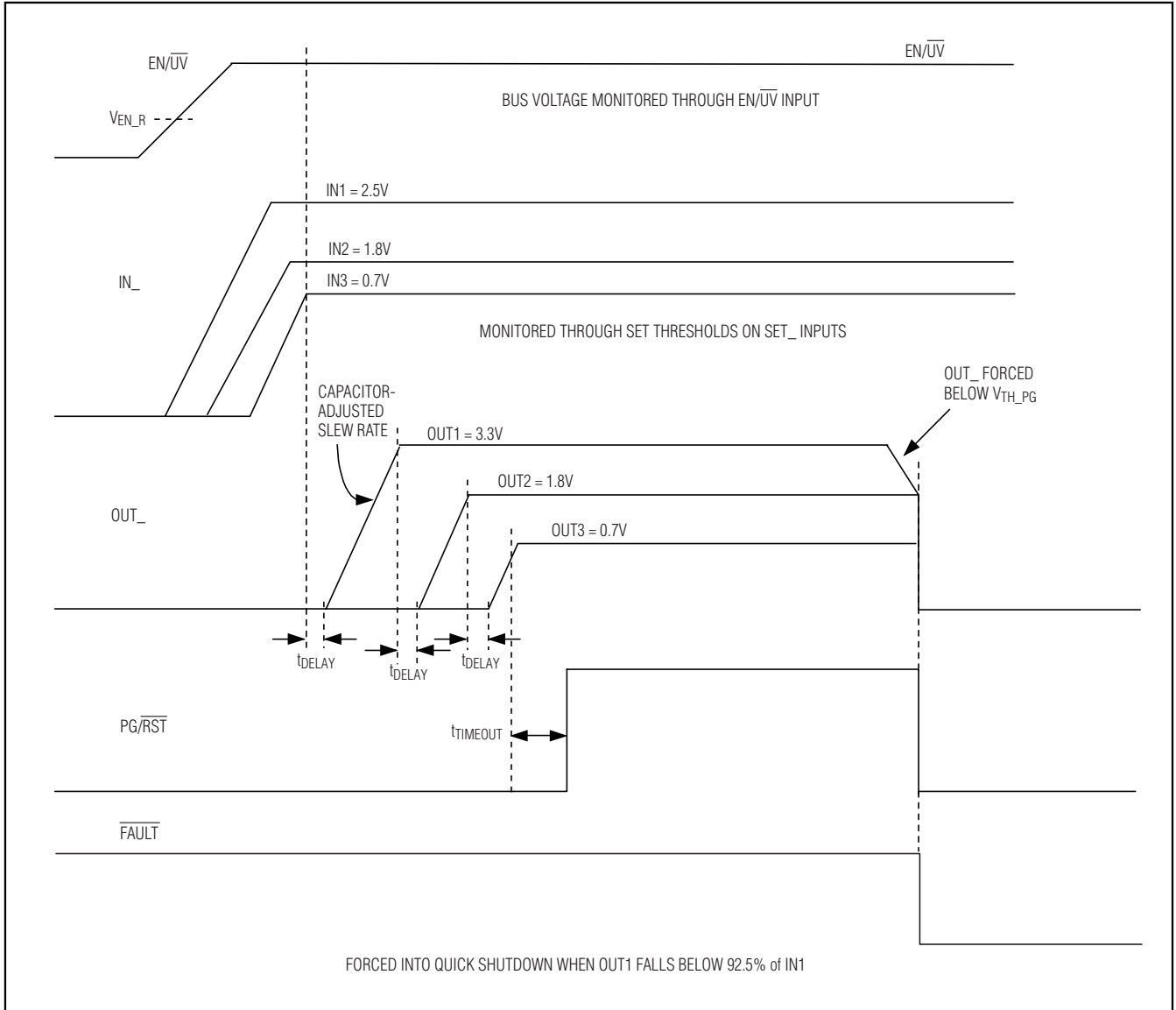

Figure 4. Sequencing in Fast Shutdown Mode

Dual-/Triple-Voltage, Power-Supply Trackers/Sequencers/Supervisors

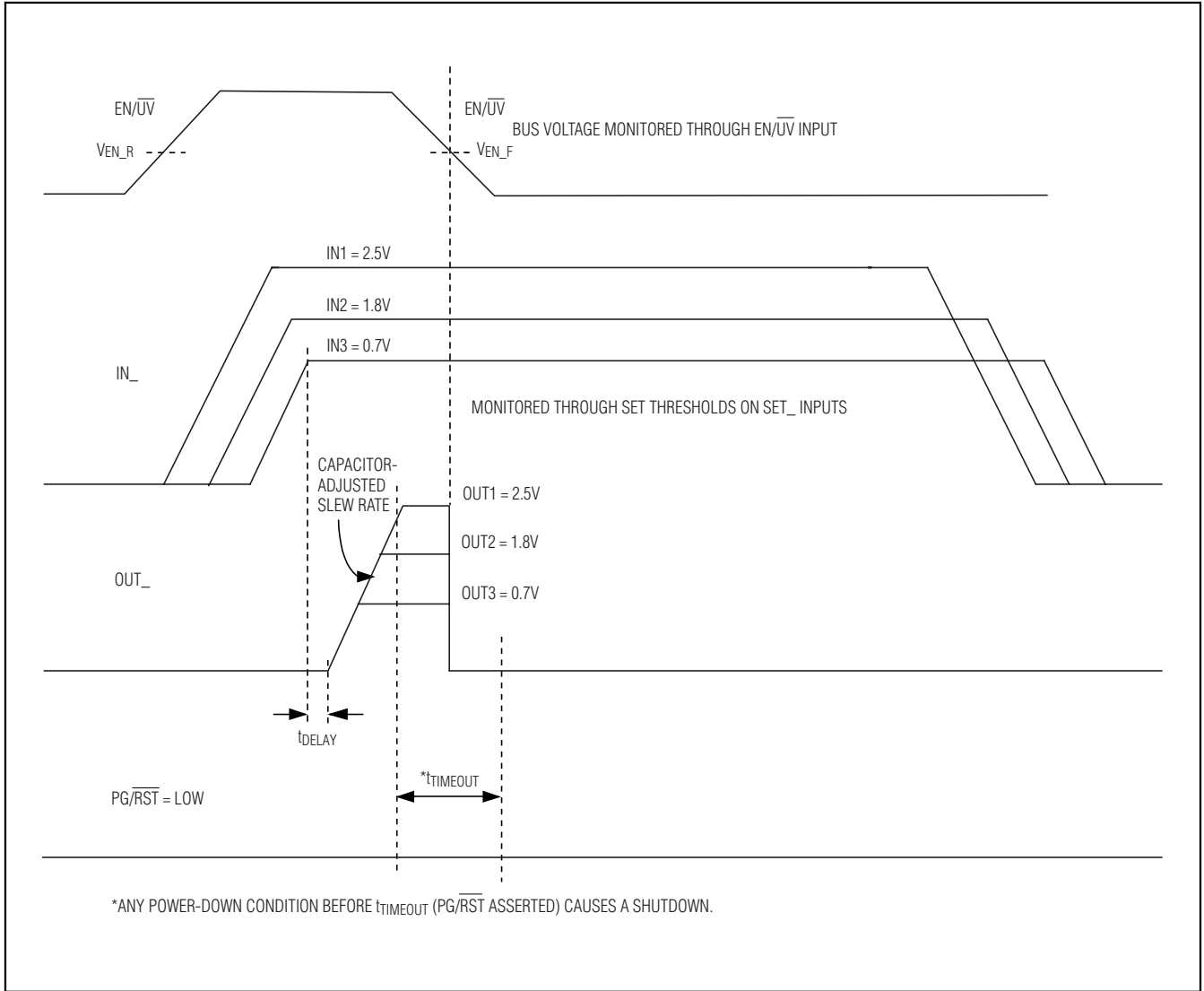

Figure 5. Timing Diagram (Aborted Tracking)

Dual-/Triple-Voltage, Power-Supply Trackers/Sequencers/Supervisors

MAX6877/MAX6878/MAX6879

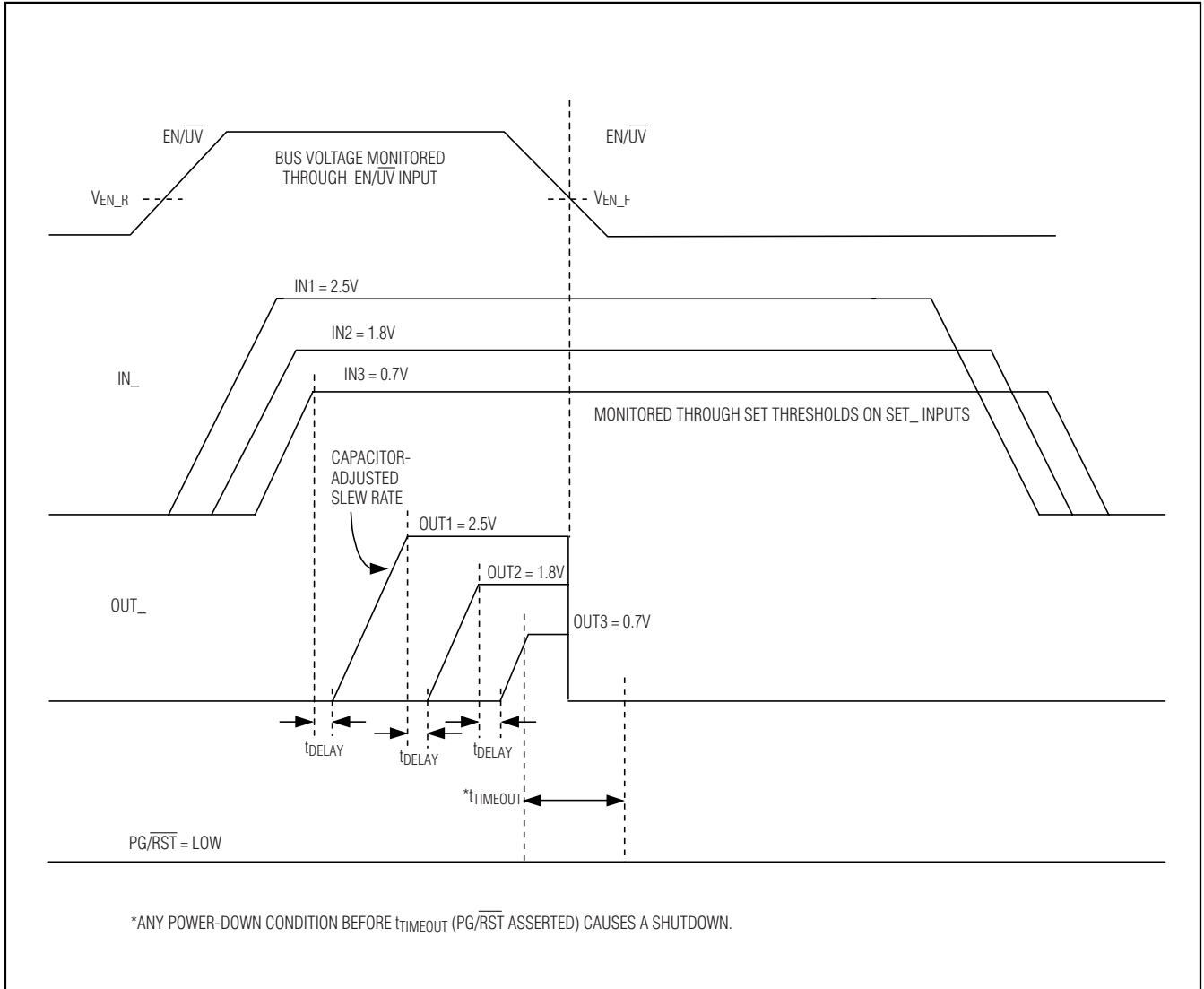

Figure 6. Timing Diagram (Aborted Sequencing)

Dual-/Triple-Voltage, Power-Supply Trackers/Sequencers/Supervisors

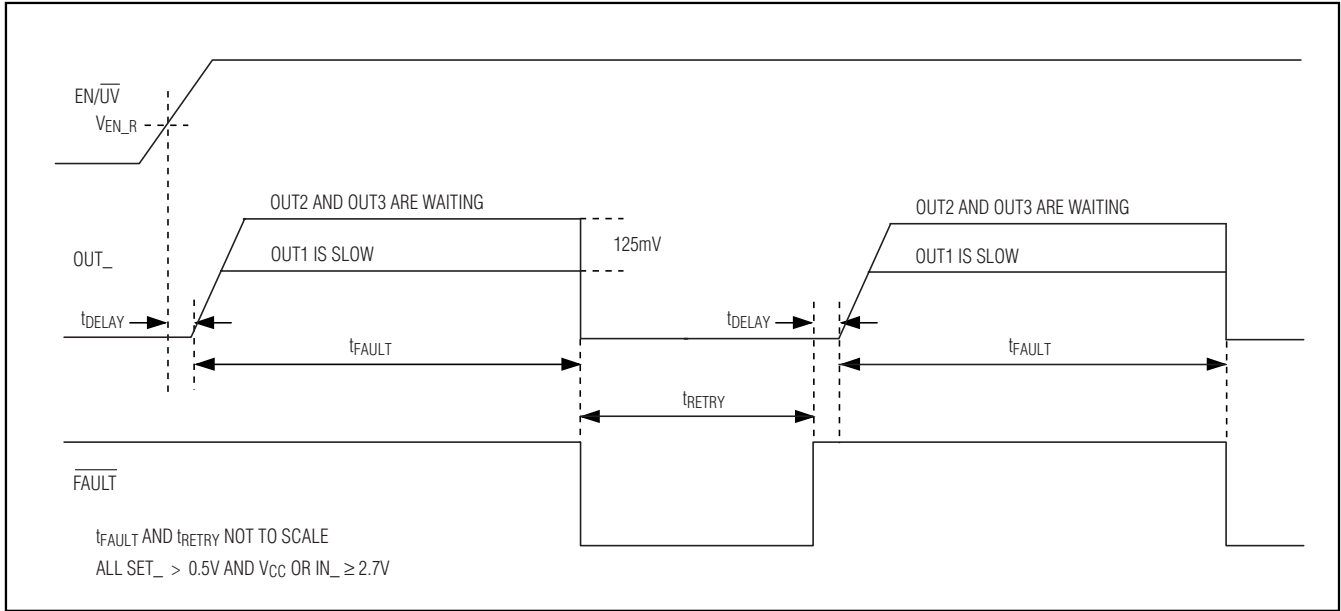

Figure 7. tFAULT and tRETRY Timing Diagram in Tracking

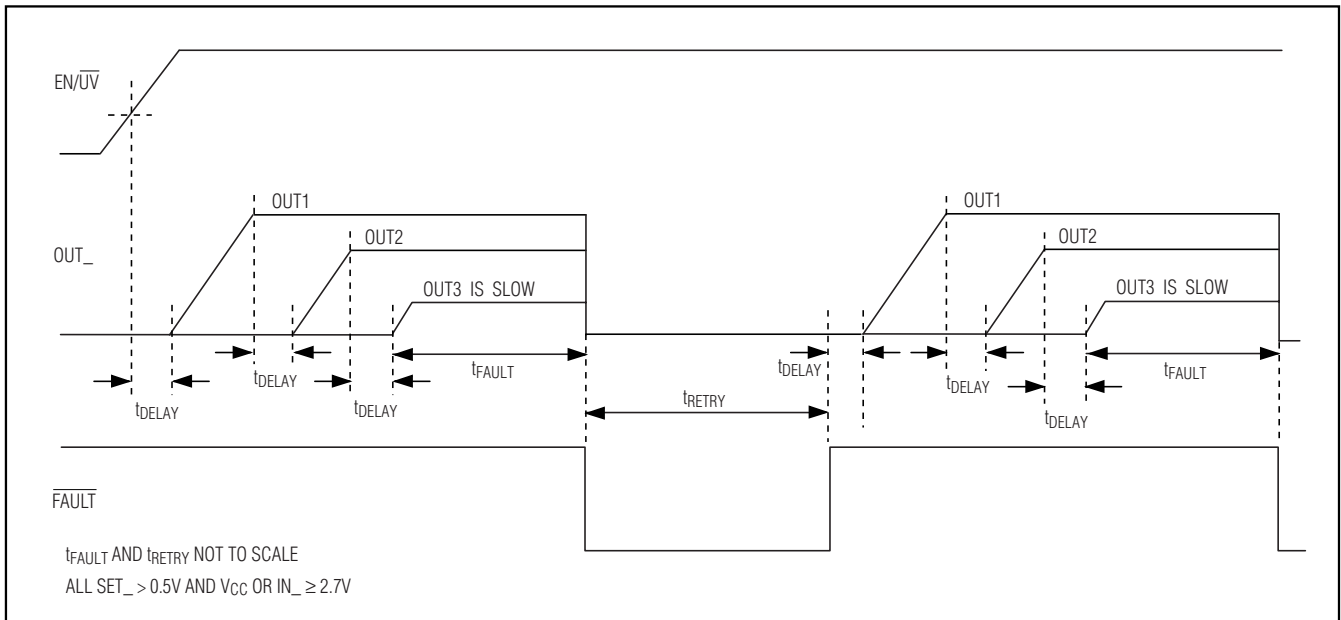
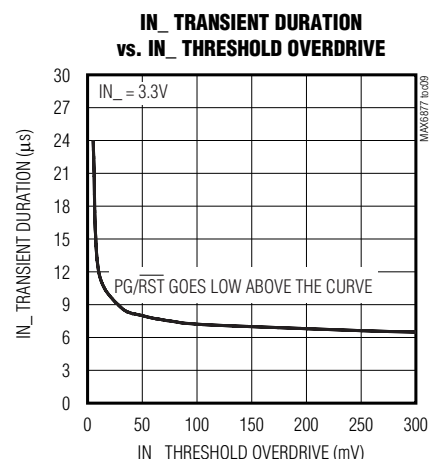
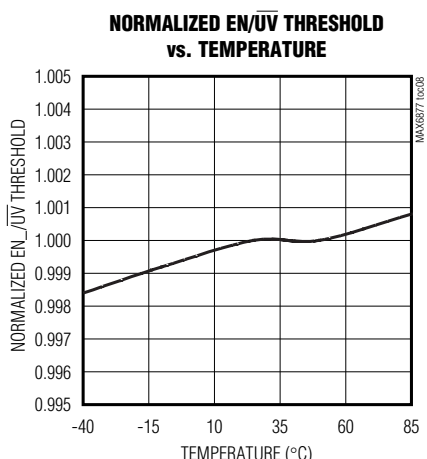
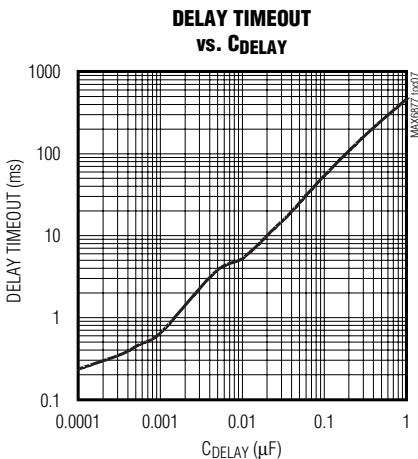
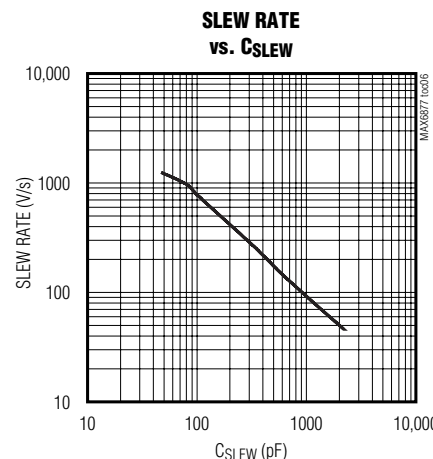
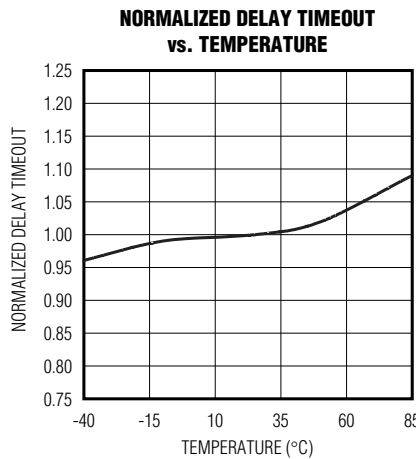
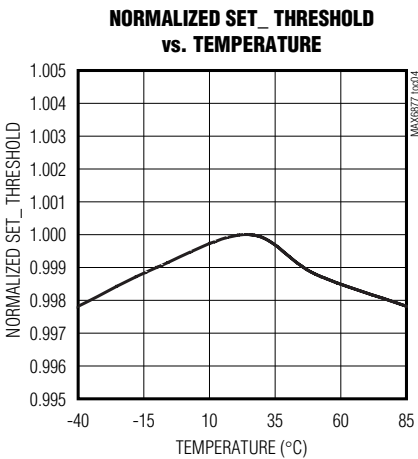
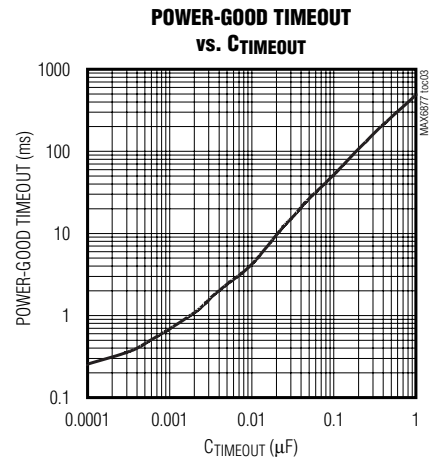
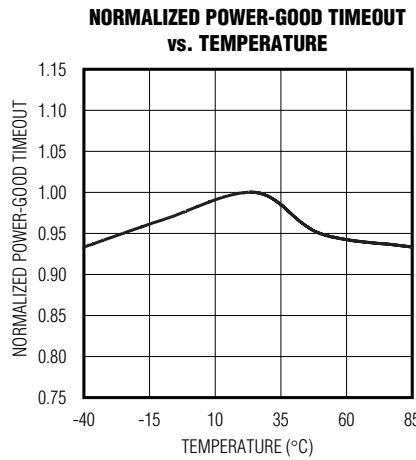
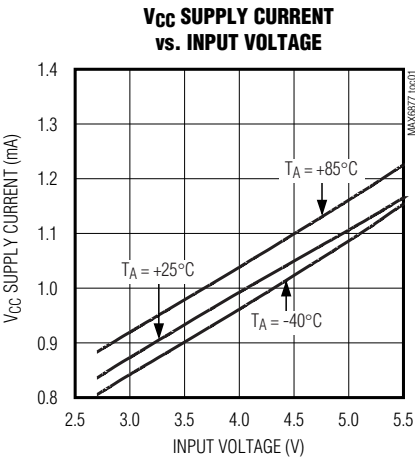

Figure 8. tFAULT and tRETRY Timing Diagram in Sequencing

Dual-/Triple-Voltage, Power-Supply Trackers/Sequencers/Supervisors

Typical Operating Characteristics

($V_{CC_} = 2.7V$ to $5.5V$, $C_{SLEW} = 200pF$, $EN = \overline{MARGIN} = ABP$, $T_A = +25^\circ C$, unless otherwise noted.)



MAX6877/MAX6878/MAX6879

Dual-/Triple-Voltage, Power-Supply Trackers/Sequencers/Supervisors

Typical Operating Characteristics (continued)

($V_{CC_} = 2.7V$ to $5.5V$, $C_{SLEW} = 200pF$, $EN = \overline{MARGIN} = ABP$, $T_A = +25^\circ C$, unless otherwise noted.)

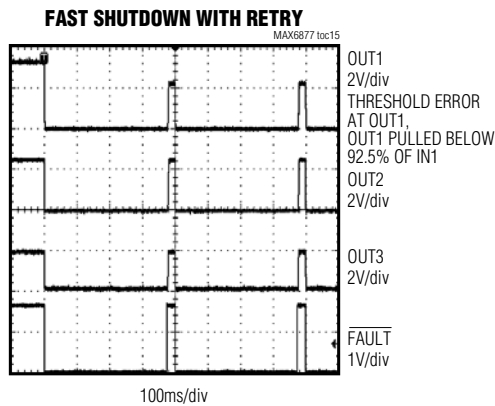
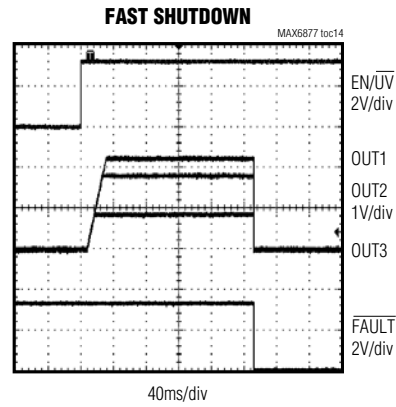
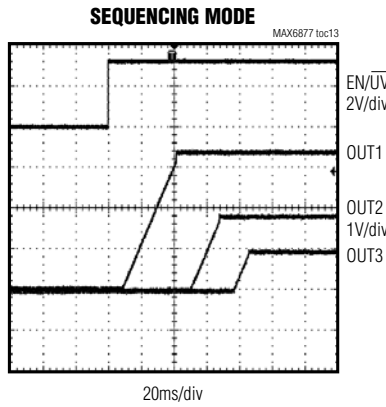
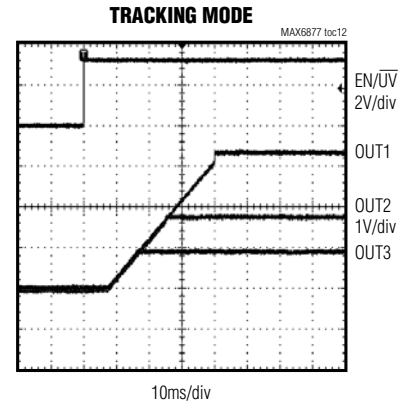
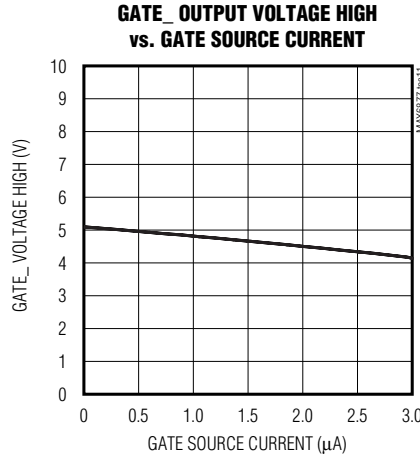
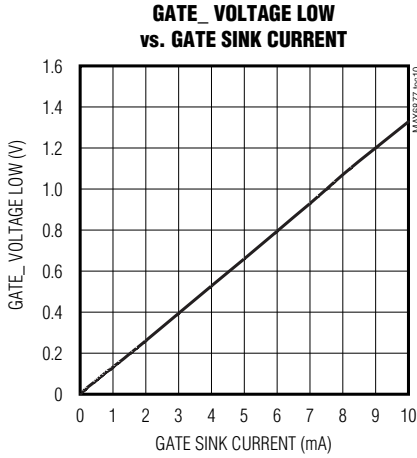

Dual-/Triple-Voltage, Power-Supply Trackers/Sequencers/Supervisors

Pin Description

PIN			NAME	FUNCTION
MAX6877	MAX6878	MAX6879		
1	1	—	V _{CC}	Optional Supply Voltage Input. Connect V _{CC} to an alternate (i.e., always-on) supply if desired. Leave V _{CC} unconnected, if not used. V _{CC} allows IN _– supplies less than UVLO to be tracked. V _{CC} is internally pulled down by a 100kΩ resistor.
2	2	1	ABP	Internal Supply Bypass Input. Bypass ABP with a 1μF capacitor to GND. ABP maintains the device supply voltage during rapid power-down conditions.
3	—	—	SET3	Externally Adjusted IN _– Undervoltage Lockout Threshold. Connect SET _– to an external resistor-divider network to set the desired undervoltage threshold for each IN _– supply (see the <i>Typical Application Circuit</i>). All SET _– inputs must be above the internal SET _– threshold (0.5V) to enable tracking or sequencing functionality.
4	4	2	SET2	
5	5	3	SET1	
—	3, 16, 17, 22	—	N.C.	No Connection. Not internally connected.
6	6	4	EN/ \overline{UV}	Logic-Enable Input or Undervoltage Lockout Monitor Input. EN/ \overline{UV} must be high (EN/ \overline{UV} > V _{EN_R}) to enable voltage tracking or sequencing power-up operation. OUT _– begins tracking down when EN/ \overline{UV} < V _{EN_F} . Connect EN/ \overline{UV} to an external resistor-divider network to set the external UVLO threshold.
7	7	5	GND	Ground
8	8	6	DELAY	Tracking Startup/Sequence Delay Select Input. Connect a capacitor from DELAY to GND to select the desired delay period before tracking is enabled (after all SET _– inputs and EN/ \overline{UV} are above their respective thresholds) or between supply sequences. Leave DELAY unconnected for the default 200μs delay period.
9	9	7	SLEW	Slew-Rate Adjustment Input. Connect a capacitor from SLEW to GND to select the desired OUT _– slew rate.
10	10	—	TIMEOUT	PG/ \overline{RST} Timeout Period Adjust Input. PG/ \overline{RST} asserts high after the timeout period when all OUT _– exceed their IN _– referenced threshold. Connect a capacitor from TIMEOUT to GND to set the desired timeout period. Leave TIMEOUT unconnected for the default 200μs delay period.
11	11	8	$\overline{LTCH/RTR}$	Latch/Autoretry Selection Input. Drive $\overline{LTCH/RTR}$ low to select the latch mode. Connect $\overline{LTCH/RTR}$ to ABP or leave unconnected to select autoretry mode. $\overline{LTCH/RTR}$ is internally pulled up to ABP through a 10μA current source.
12	12	9	$\overline{TRK/SEQ}$	Track/Sequence Select Input. Drive $\overline{TRK/SEQ}$ low to enable supply tracking function. Connect $\overline{TRK/SEQ}$ to ABP or leave it unconnected to enable supply sequencing. $\overline{TRK/SEQ}$ is internally pulled to ABP through a 10μA current source.
13	13	—	\overline{MARGIN}	Margin Input, Active-Low. Drive \overline{MARGIN} low to enable margin mode (see the <i>Margin</i> section). The \overline{MARGIN} functionality is disabled (returns to normal monitoring mode) after \overline{MARGIN} returns high. \overline{MARGIN} is internally pulled up to ABP through a 10μA current source.

MAX6877/MAX6878/MAX6879

Dual-/Triple-Voltage, Power-Supply Trackers/Sequencers/Supervisors

Pin Description (continued)

PIN			NAME	FUNCTION
MAX6877	MAX6878	MAX6879		
14	14	—	PG/ $\overline{\text{RST}}$	Power-Good Output, Open-Drain. PG_ $\overline{\text{RST}}$ asserts high t _{TIMEOUT} after all OUT_ voltages exceed the V _{TH_PG} thresholds.
15	15	10	$\overline{\text{FAULT}}$	Tracking Fault Alert Output, Active Low, Open-Drain. $\overline{\text{FAULT}}$ asserts low if a tracking failure is present for longer than the selected fault period or if tracking voltages fail by more than $\pm 250\text{mV}$. $\overline{\text{FAULT}}$ asserts low if any OUT_ falls below the corresponding IN_ voltage.
16	—	—	OUT3	Channel 3 Monitored Output Voltage. Connect OUT3 to the source of an n-channel FET. A fault condition activates a 100 Ω pulldown to ground.
17	—	—	GATE3	Gate Drive for External n-Channel FET. An internal charge pump boosts GATE3 to V _{IN3} + 5V to fully enhance the external n-channel FET when power-up is complete.
18	18	11	OUT2	Channel 2 Monitored Output Voltage. Connect OUT2 to the source of an n-channel FET. A fault condition activates a 100 Ω pulldown to ground.
19	19	12	GATE2	Gate Drive for External n-Channel FET. An internal charge pump boosts GATE2 to V _{IN2} + 5V to fully enhance the external n-channel FET when power-up is complete.
20	20	13	OUT1	Channel 1 Monitored Output Voltage. Connect OUT1 to the source of an n-channel FET. A fault condition activates a 100 Ω pulldown to ground.
21	21	14	GATE1	Gate Drive for External n-Channel FET. An internal charge pump boosts GATE1 to V _{IN1} + 5V to fully enhance the external n-channel FET when power-up is complete.
22	—	—	IN3	Supply Input Voltage. IN1, IN2, or IN3 must be greater than the internal undervoltage lockout (V _{ABP} = 2.7V) to enable the tracking or sequencing functionality. Each IN_ input is simultaneously monitored by SET_ inputs to ensure all supplies have stabilized before power-up is enabled. If IN_ is connected to ground or left unconnected and SET_ is above 0.5V, then no-sequencing control is performed on that channel. Each IN_ is internally pulled down by a 100k Ω resistor.
23	23	15	IN2	
24	24	16	IN1	
EP	EP	EP	EP	Exposed Paddle. Connect exposed paddle to ground.

Dual-/Triple-Voltage, Power-Supply Trackers/Sequencers/Supervisors

Functional Diagram

MAX6877/MAX6878/MAX6879

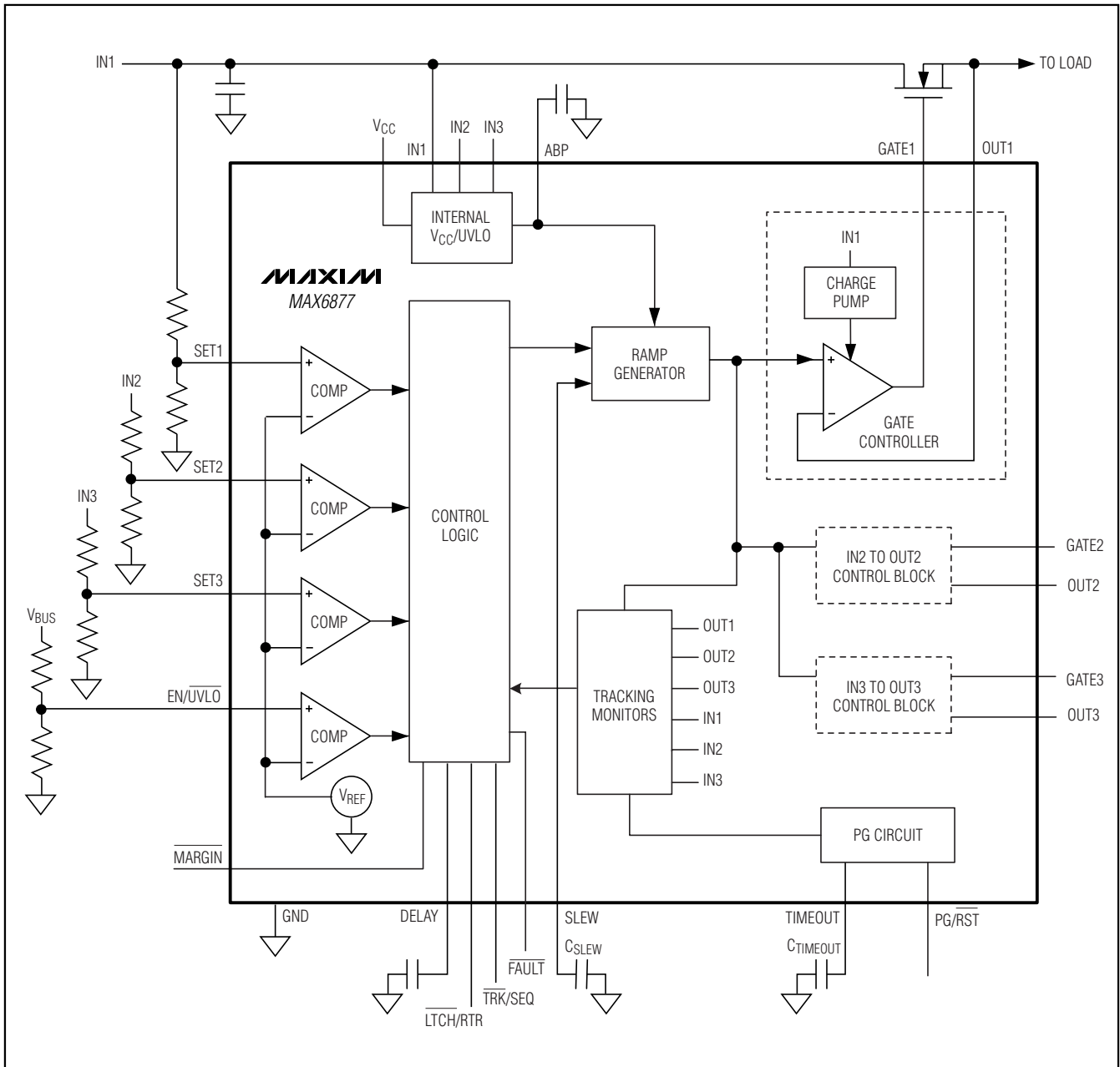

Dual-/Triple-Voltage, Power-Supply Trackers/Sequencers/Supervisors

Detailed Description

The MAX6877/MAX6878/MAX6879 multivoltage power trackers/sequencers/supervisors monitor up to three system voltages and provide proper power-up and power-down control for systems requiring voltage tracking or sequencing. These devices ensure controlled voltage tracking with a specified range or sequencing in the proper order as system power supplies are enabled. The MAX6877/MAX6878/MAX6879 generate all required voltages and timing to control up to three external n-channel pass FETs for the OUT1/OUT2/OUT3 supply voltages (see the *Selector Guide* for different features of each device.)

The MAX6877/MAX6878/MAX6879 feature adjustable undervoltage thresholds for each input supply. When all the voltages are above these adjusted thresholds, the devices turn on the external n-channel MOSFETs to either sequence or track the voltages to the system. During the voltage-tracking mode, the voltage at the GATE of each MOSFET is increased to slowly bring up all supplies at a controlled slew rate. The voltage at the source (output) of each MOSFET is internally compared to a control ramp to maintain a low differential between each monitored supply. Tracking is dynamically adjusted to force all outputs to track within 125mV of the reference ramp. If for any reason any supplies fail to track within $\pm 250\text{mV}$ of the reference ramp, the FAULT output is asserted, the power-up mode is terminated, and all outputs are quickly powered off. In sequencing mode, the outputs are turned on one after the other, OUT1 first and OUT3 last. The MAX6877/MAX6878/MAX6879 feature an autoretry or latch-off mode with capacitor-adjusted timing.

These devices also provide a controlled power-down (tracking mode) when the system shuts off in an orderly manner. When an unexpected fault occurs, the outputs are all pulled down simultaneously with an internal 100Ω pulldown to help discharge capacitive loads at the MOSFET's source.

The MAX6877/MAX6878/MAX6879 feature independent internal charge pumps to fully enhance the external FETs for low-voltage drops at highpass currents. The MAX6877/MAX6878 also feature a power-good output with a selectable timeout period that can be used for system reset.

The MAX6877/MAX6878/MAX6879 monitor up to three voltages. Devices may be configured to exclude any IN_x . To disable the tracking or sequencing operation of any IN_x , connect the IN_x to ground (or leave unconnected) and connect SET_x to a voltage greater than 0.5V. The channel exclusion feature adds more flexibility

to the device in a variety of different applications. As an example, the MAX6877 can track or sequence two voltages using IN1 and IN2 while IN3 is left disabled.

Powering the MAX6877/MAX6878/MAX6879

These devices derive power from either the IN1, IN2, or IN3 voltage inputs or V_{CC} (see the *Functional Diagram*). V_{CC} or one of the IN_x inputs must be at least +2.7V to ensure full device operation.

The highest input voltage on IN1/IN2/IN3 or V_{CC} supplies power to the devices. Internal hysteresis ensures that the supply input that initially powers these devices continues to power the MAX6877/MAX6878/MAX6879 when multiple input voltages are within 100mV (typ) of each other.

ABP

ABP powers the analog circuitry. Bypass ABP to GND with a $1\mu\text{F}$ ceramic capacitor installed as close to the device as possible. ABP takes the highest voltage of IN_x or V_{CC} . Do not use ABP to provide power to external circuitry. ABP maintains the device supply voltage during rapid power-down conditions.

Tracking and Sequencing Modes (TRK/SEQ)

To enable the power-up/power-down voltage-tracking operation, drive $\overline{\text{TRK/SEQ}}$ low (connect $\overline{\text{TRK/SEQ}}$ to GND). To enable power-up sequencing and power-down tracking functions, drive $\overline{\text{TRK/SEQ}}$ high (connect $\overline{\text{TRK/SEQ}}$ to ABP) or leave it unconnected. $\overline{\text{TRK/SEQ}}$ is internally pulled to ABP through a $10\mu\text{A}$ current source (see Figures 1 and 3).

Tracking

To operate in tracking mode, connect $\overline{\text{TRK/SEQ}}$ to GND. When $V_{\text{EN/UV}} > 1.25\text{V}$ and all SET_x inputs are above the internal SET_x threshold (0.5V), the tracking process is initiated. The MAX6877/MAX6878/MAX6879 generate an internal reference ramp voltage that drives the control loops for the tracked voltages. The tracking functionality is monitored with a comparator control block for each output (see the *Functional Diagram*). The comparators monitor each OUT_x voltage with respect to the common reference ramp voltage to ensure the OUT_x voltages stay within 125mV of the reference ramp, monitor each tracked output voltage with respect to its source input voltage, and monitor each output voltage with respect to GND during power-up/retry cycles. If for any reason any supplies fail to track within $\pm 250\text{mV}$ of the reference ramp, the FAULT output is asserted, the power-up mode is terminated, and all outputs are quickly powered off.

Dual-/Triple-Voltage, Power-Supply Trackers/Sequencers/Supervisors

During ramp up, if an OUT_ voltage is less than the reference ramp voltage by more than 125mV, the control loop dynamically stops the control ramp voltage from rising until the slow OUT_ voltage catches up. If an OUT_ voltage is greater or less than the reference ramp voltage by more than 250mV, a fault is signaled and a power-down phase is initiated.

The slew rate for the reference ramp voltage is capacitor adjustable. Connect a capacitor from SLEW to ground to select the desired OUT_ slew rate. When all OUT_ voltages have exceeded the V_{TH_PG} percentage of the IN_ voltage (external n-channel FET is saturated), PG/RST asserts high after t_{TIMEOUT} indicating successful tracking.

Sequencing

The sequencing operation can be initiated after all input conditions for power-up are met V_{EN/UV} > 1.25V and all SET_ inputs are above the internal SET_ threshold (0.5V). In sequencing mode, the outputs are turned on sequentially, OUT1 first and OUT3 last. Before turning on each channel, a delay period occurs as in Figure 3 (programmable by connecting a capacitor from DELAY to ground). The power-up phase for each channel ends when its output voltage exceeds a fixed percentage (V_{TH_PG}) of the corresponding IN_ voltage. When all channels have exceeded these thresholds, PG/RST asserts high after t_{TIMEOUT}, indicating a successful sequence.

If there is a fault condition during the initial power-up sequence, the process is aborted.

When powering down, all outputs turn off simultaneously, tracking each other. No reverse power-down sequencing occurs.

Power-Up and Power-Down

During power-up, the OUT_ is forced to follow the internal reference ramp voltage by an internal loop that controls the GATE_ of the external MOSFET. This phase must be completed within the adjustable fault timeout period; otherwise, the part forces a shutdown on all GATE_.

Once the power-up is completed, a power-down phase can be initiated by forcing V_{EN/UV} below V_{EN_F}. The reference voltage ramp ramps down at the capacitor-adjusted slew rate. The control-loop comparators monitor each OUT_ voltage with respect to the common reference ramp voltage. During ramp down, if an OUT_ voltage is greater than the reference ramp voltage by more than V_{TRK}, the control loop dynamically stops the control ramp voltage from decreasing until the slow OUT_ voltage catches up. If an OUT_ voltage is greater

or less than the reference ramp voltage by more than V_{TRK_F}, a fault is signaled and the fast-shutdown mode is initiated. In fast-shutdown mode, a 100Ω pulldown resistor is connected from OUT_ to GND to quickly discharge capacitance at OUT_ and GATE_ is pulled low with a strong IGDS current (see Figures 2 and 4).

Figures 5 and 6 show aborted tracking and sequencing modes. When EN/UV goes low before t_{TIMEOUT} expires, all the outputs go low and the device goes into fast shutdown.

Internal Pulldown

To ensure that the OUT_ voltages are not held high by a large output capacitance after a fault has occurred, there is a 100Ω internal pulldown at OUT_. The pulldown ensures that all OUT_ voltages are below V_{TH_PL} (referenced to GND) before power-up cycling is initiated. The internal pulldown also ensures a fast discharge of the output capacitor during fast shutdown and fault modes. The pulldowns are not present during normal operation.

Stability Comment

No external compensation is required for tracking or slew-rate control.

Inputs

IN1/IN2/IN3

The highest voltage on V_{CC}, IN1, IN2, or IN3 supplies power to the device. The undervoltage threshold for each IN_ supply is set with an external resistor-divider from each IN_ to SET_ to ground.

Undervoltage Lockout Threshold Inputs (SET_)

The MAX6877 features three and the MAX6878/MAX6879 feature two externally adjustable IN_ undervoltage lockout (UVLO) thresholds (SET1, SET2, SET3) to enable sequencing/tracking functionality. The undervoltage threshold for each IN_ supply is set with an external resistor-divider from each IN_ to SET_ to ground (see Figure 9). All SET_ inputs must be above the internal SET_ threshold (0.5V) to enable tracking/sequencing functionality. Use the following formula to set the UVLO threshold:

$$V_{IN_} = V_{TH} (R1 + R2) / R2$$

where V_{IN_} is the undervoltage lockout threshold and V_{TH} is the 500mV SET threshold.

Margin Input (MARGIN)

MARGIN allows system-level testing while power supplies are below the normal ranges as adjusted by the SET_ inputs. Drive MARGIN low before varying system

Dual-/Triple-Voltage, Power-Supply Trackers/Sequencers/Supervisors

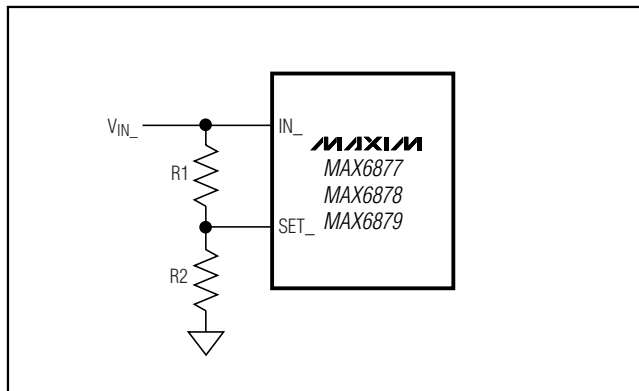

Figure 9. Setting the Undervoltage (UVLO) Thresholds

voltages below the adjusted thresholds to avoid signaling an error. The state of $\overline{\text{PG/RST}}$ and $\overline{\text{FAULT}}$ outputs does not change while $\overline{\text{MARGIN}}$ is low. $\overline{\text{PG/RST}}$, $\overline{\text{FAULT}}$, and all monitoring functions are disabled while $\overline{\text{MARGIN}}$ is low. $\overline{\text{MARGIN}}$ makes it possible to vary the supplies without a need to adjust the thresholds to prevent tracker/sequencer alerts or faults. Drive $\overline{\text{MARGIN}}$ high or leave it unconnected for normal operating mode.

Slew-Rate Control Input (SLEW)

The reference ramp voltage slew rate during any controlled power-up/down phase can be programmed in the 90V/s to 950V/s range by connecting a capacitor (C_{SLEW}) from SLEW to ground. Use the following formula to calculate the typical slew rate:

$$\text{Slew Rate} = (9.35 \times 10^{-8}) / C_{\text{SLEW}}$$

where slew rate is in V/s and C_{SLEW} is in farads.

The capacitor at C_{SLEW} also sets the $\overline{\text{FAULT}}$ timeout period (t_{FAULT}) and $\overline{\text{FAULT}}$ retry timeout period (t_{RETRY}) (see Table 1).

For example, if $C_{\text{SLEW}} = 100\text{pF}$, we have $t_{\text{RETRY}} = 350\text{ms}$, $t_{\text{FAULT}} = 21.91\text{ms}$, slew rate = 935V/s. For example, if $C_{\text{SLEW}} = 1\text{nF}$, we have $t_{\text{RETRY}} = 3.5\text{s}$, $t_{\text{FAULT}} = 219\text{ms}$, slew rate = 93.5V/s.

C_{SLEW} is the capacitor on the SLEW pad, and must be large enough to make the parasitic capacitance negligible. C_{SLEW} should be in the range of $100\text{pF} < C_{\text{SLEW}} < 1\text{nF}$.

Table 1. C_{SLEW} Timing Formulas

TIME PERIOD	FORMULAS
Slew Rate	$(9.35 \times 10^{-8}) / C_{\text{SLEW}}$
t_{RETRY}	$3.506 \times 10^9 \times C_{\text{SLEW}}$
t_{FAULT}	$2.191 \times 10^8 \times C_{\text{SLEW}}$

Limiting Inrush Current

The capacitor connected at SLEW controls the OUT_S slew rate, thus controlling the inrush current required to charge the load capacitor at the outputs (OUT_). Using the programmed slew rate, limit the inrush current by using the following formula:

$$I_{\text{INRUSH}} = C_{\text{OUT}} \times \text{SR}$$

where I_{INRUSH} is in amperes, C_{OUT} is in farads, and SR is in V/s.

Delay Time Input (DELAY)

To adjust the desired delay period (t_{DELAY}) before tracking/sequencing is enabled, connect a capacitor (C_{DELAY}) between DELAY to ground (see Figures 1 to 8). The selected delay time is also enforced when EN/ $\overline{\text{UV}}$ rises from low to high when all the input voltages (IN1/IN2/IN3) are present. Use the following formula to calculate the delay time:

$$t_{\text{DELAY}} = 200\mu\text{s} + (500\text{k}\Omega \times C_{\text{DELAY}})$$

where t_{DELAY} is in μs and C_{DELAY} is in farads. Leave DELAY unconnected for the default 200 μs delay.

Timeout Period Input (TIMEOUT)

These devices feature a $\overline{\text{PG/RST}}$ timeout period. Connect a capacitor (C_{TIMEOUT}) from TIMEOUT to ground to program the $\overline{\text{PG/RST}}$ timeout period. After all OUT_ outputs exceed their IN_ referenced thresholds ($V_{\text{TH_PG}}$), $\overline{\text{PG/RST}}$ remains low for the selected timeout period, t_{TIMEOUT} (see Figure 3):

$$t_{\text{TIMEOUT}} = 200\mu\text{s} + (500\text{k}\Omega \times C_{\text{TIMEOUT}})$$

where t_{TIMEOUT} is in μs and C_{TIMEOUT} is in farads. Leave TIMEOUT unconnected for the default 200 μs timeout delay.

Logic-Enable Input (EN/ $\overline{\text{UV}}$)

Drive logic EN/ $\overline{\text{UV}}$ input above $V_{\text{EN_R}}$ to initiate voltage tracking/sequencing during the power-up operation. Drive logic EN/ $\overline{\text{UV}}$ below $V_{\text{EN_F}}$ to initiate tracking power-down operation. Connect EN/ $\overline{\text{UV}}$ to an external resistor-divider network to set the external undervoltage lockout threshold.

OUT1/OUT2/OUT3

The MAX6877 monitors three and MAX6878/MAX6879 monitor two OUT_ outputs to control the tracking/sequencing performance. After the internal supply (ABP) exceeds the minimum voltage (2.7V) requirements, EN/ $\overline{\text{UV}} > V_{\text{EN_R}}$, and IN1/IN2/IN3 are all greater than their adjusted SET_ thresholds, OUT1/OUT2/OUT3 begin to track or sequence.

Dual-/Triple-Voltage, Power-Supply Trackers/Sequencers/Supervisors

During fault conditions, an internal pulldown resistor (100Ω) on OUT_ is enabled to help discharge load capacitance (100Ω is connected for fast power-down control).

Outputs

GATE_

The MAX6877/MAX6878/MAX6879 feature up to three GATE_ outputs to drive up to three external n-channel FET gates. The following conditions must be met before GATE_ begins enhancing the external n-channel FET_:

- 1) All SET_ inputs (SET1–SET3) are above their 0.5V thresholds.
- 2) At least one IN_ input or VCC is above the minimum operating voltage (2.7V).
- 3) $EN/\overline{UV} > 1.25V$.

At power-up mode, GATE_ voltages are enhanced by control loops so that all OUT_ voltages track together at a capacitor-adjusted slew rate. Each GATE_ is internally pulled up to 5V above its relative IN_ voltage to fully enhance the external n-channel FET when power-up is complete.

FAULT

The MAX6877/MAX6878/MAX6879 include an open-drain, active-low tracking fault alarm output (FAULT). FAULT asserts low when a power-up phase is not completed within the specified fault period or if OUT_ voltages are more than VTRK_F.

The fault time period (tFAULT) is set through the capacitor at SLEW (CSLEW). Use the following formula to estimate the fault timeout period:

$$t_{FAULT} = 2.191 \times 10^8 \times C_{SLEW}$$

Power-supply tracking operation should be completed within the selected fault timeout period (tFAULT). The total tracking time is extended when the devices must vary the control slew rate to allow slow supplies to catch up. If the external FET is too small (RDS is too high for the selected load current and IN_ source current), the OUT_ voltage may never reach the control ramp voltage. For a slew rate of 935V/s, a fault is signaled if all outputs have not stabilized within 22ms. For a slew rate of 93.5V/s, a fault is signaled if tracking takes too long (more than 219ms).

During power-up, only the condition, $OUT_ < \text{ramp} - V_{TRK}$, is monitored in order to stop the ramp. However, both conditions $OUT_ < \text{ramp} - V_{TRK_F}$ and $OUT_ > \text{ramp} + V_{TRK_F}$ cause a fault. During power-down, only the condition $OUT_ > \text{ramp} + V_{TRK}$ is checked in order to stop the ramp. However, both conditions $OUT_ < \text{ramp} - V_{TRK_F}$ and $OUT_ > \text{ramp} + V_{TRK_F}$ cause a fault (see Figure 10). OUT1, OUT2, and OUT3 are tracked within VTRK_F (mV) (power-up tracking and power-down), and if they differ by more than $2 \times V_{TRK_F}$ a fault condition is asserted.

Retry time period (tRETRY) is defined as $16 \times t_{FAULT}$. To calculate the retry time period use the following formula:

$$t_{RETRY} = 3.506 \times 10^9 \times C_{SLEW}$$

where tRETRY is in μs and CSLEW is in farads.

Autoretry and Latch-Off Functions (LTCH/RTR)

The MAX6877/MAX6878/MAX6879 feature latch-off or autoretry modes to power-on again after a fault condition has been detected. Connect LTCH/RTR to ground to set the latch-off mode. To select autoretry mode, connect LTCH/RTR to ABP or leave unconnected.

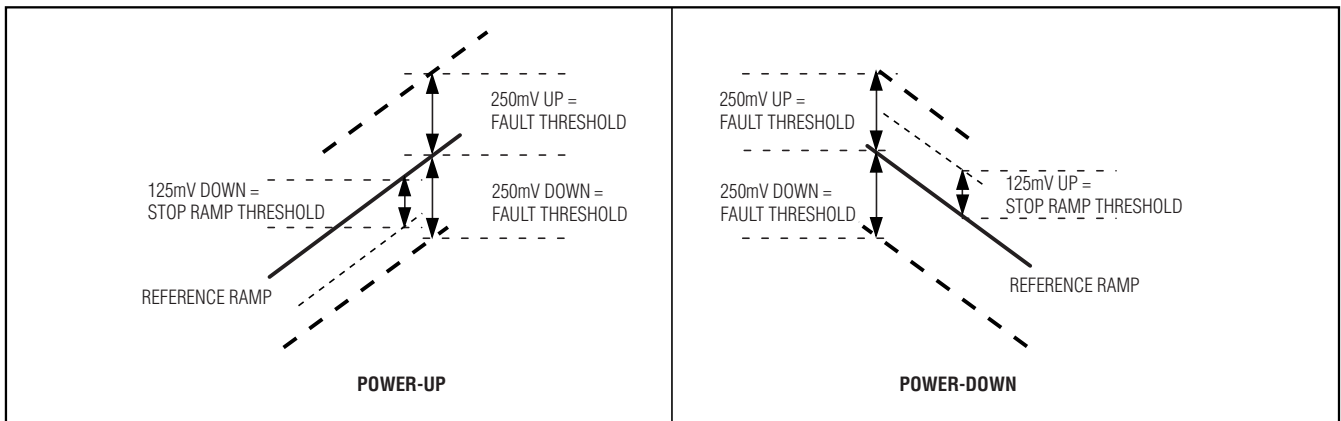

Figure 10. Stop Ramp FAULT Window During Power-Up and Power-Down

Dual-/Triple-Voltage, Power-Supply Trackers/Sequencers/Supervisors

When a fault is detected, for a period of t_{RETRY} , $GATE_{\overline{}}$ remains off and the 100Ω pull-downs are turned on. After the t_{RETRY} period, the device waits t_{DELAY} and retries power-up if all power-up conditions are met (see Figure 8). These include all $V_{SET_} > 0.5V$, $EN/\overline{UV} > V_{EN_R}$, $OUT_{\overline{}}$ voltages $< V_{TH_PL}$. The autoretry period, t_{RETRY} , is a function of $CSLEW$; see Table 1.

When the device is in latch mode and a fault occurs, \overline{FAULT} asserts and all outputs are latched off. To unlatch $OUT_{\overline{}}$ after a fault disappears, cycle EN/\overline{UV} or cycle V_{CC} and the inputs ($IN_{\overline{}}$) below the 2.7V $UVLO$ threshold. After EN/\overline{UV} goes high, the device waits a t_{RETRY} period then tries to power-up again. If V_{CC} and all $IN_{\overline{}}$ are cycled below 2.7V, the device tries to power-up immediately.

Power-Good Output (PG/\overline{RST})

The MAX6877/MAX6878 include a power-good (PG/\overline{RST}) output. PG/\overline{RST} is an open-drain output and requires an external pullup resistor.

All the $OUT_{\overline{}}$ outputs must exceed their $IN_{\overline{}}$ referenced thresholds ($IN_{\overline{}} \times V_{TH_PG}$) for the selected reset timeout period $t_{TIMEOUT}$ (see the *TIMEOUT Period Input* section) before PG/\overline{RST} asserts high. PG/\overline{RST} stays low for the selected reset timeout period ($t_{TIMEOUT}$) after all the $OUT_{\overline{}}$ voltages exceed their $IN_{\overline{}}$ referenced thresholds. PG/\overline{RST} goes low when $V_{SET_} < V_{TH}$ or $V_{EN/\overline{UV}} < V_{EN_R}$ (see Figure 3).

Applications Information

MOSFET Selection

The external pass MOSFET is connected in series with the sequenced power-supply source. Since the load current and the MOSFET drain-to-source impedance (R_{DS}) determine the voltage drop, the on characteristics of the MOSFET affect the load supply accuracy. The MAX6877/MAX6878/MAX6879 fully enhance the external MOSFET out of its linear range to ensure the lowest drain-to-source on-impedance. For highest supply accuracy/lowest voltage drop, select a MOSFET with an appropriate drain-to-source on-impedance with a gate-to-source bias of 4.5V to 6.0V.

Layout and Bypassing

For better noise immunity, bypass each of the $IN_{\overline{}}$ inputs to GND with $0.1\mu F$ capacitors installed as close to the device as possible. Bypass ABP to GND with a $1\mu F$ capacitor installed as close to the device as possible. ABP is an internally generated voltage and must not be used to supply power to external circuitry.

Selector Guide

PART	CHANNEL	TIMEOUT SELECTABLE	PG/\overline{RST}	\overline{MARGIN}	V_{CC}
MAX6877	3	Yes	Yes	Yes	Yes
MAX6878	2	Yes	Yes	Yes	Yes
MAX6879	2	No	No	No	No

Dual-/Triple-Voltage, Power-Supply Trackers/Sequencers/Supervisors

Typical Application Circuit

MAX6877/MAX6878/MAX6879

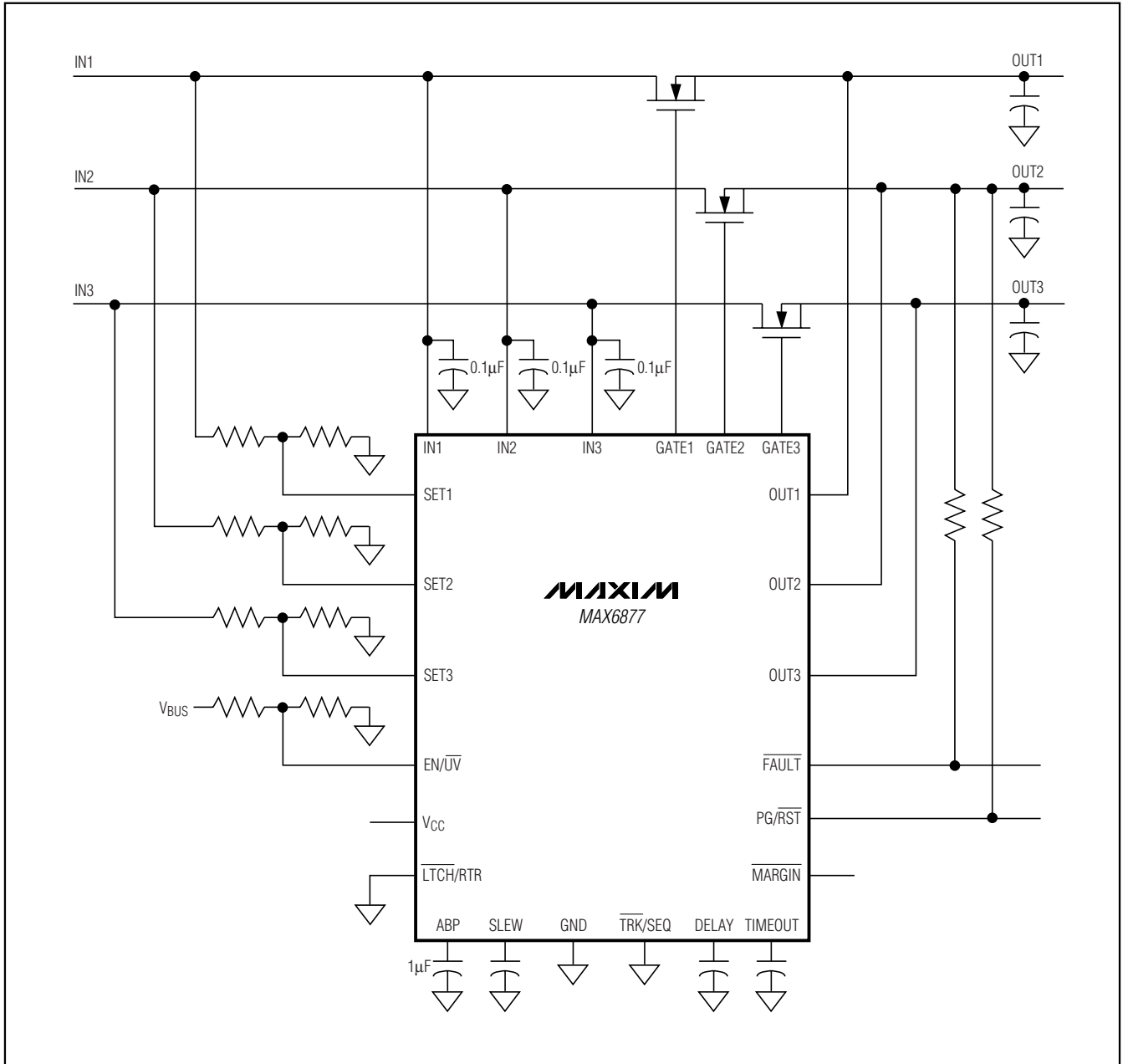

Dual-/Triple-Voltage, Power-Supply Trackers/Sequencers/Supervisors

Ordering Information (continued)

PART	TEMP RANGE	PIN-PACKAGE	PKG CODE
MAX6878ETG+*	-40°C to +85°C	24 Thin QFN	T2444-4
MAX6878ETG*	-40°C to +85°C	24 Thin QFN	T2444-4
MAX6879ETE+	-40°C to +85°C	16 Thin QFN	T1644-4
MAX6879ETE	-40°C to +85°C	16 Thin QFN	T1644-4

*Future product—contact factory for availability.
 +Denotes lead-free package.

Chip Information

PROCESS: BiCMOS

Pin Configurations (continued)

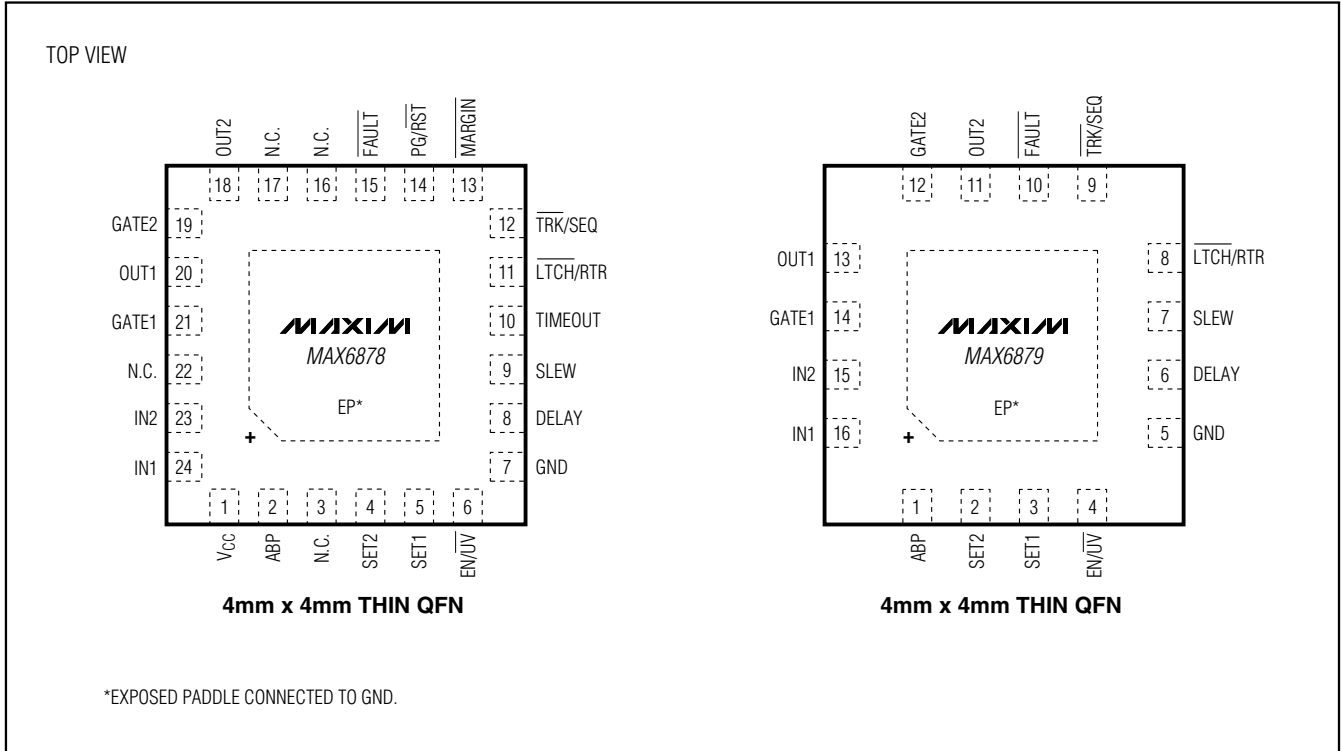

Dual-/Triple-Voltage, Power-Supply Trackers/Sequencers/Supervisors

Package Information

(The package drawing(s) in this data sheet may not reflect the most current specifications. For the latest package outline information, go to www.maxim-ic.com/packages.)

MAX6877/MAX6878/MAX6879

24L QFN THIN EPSS

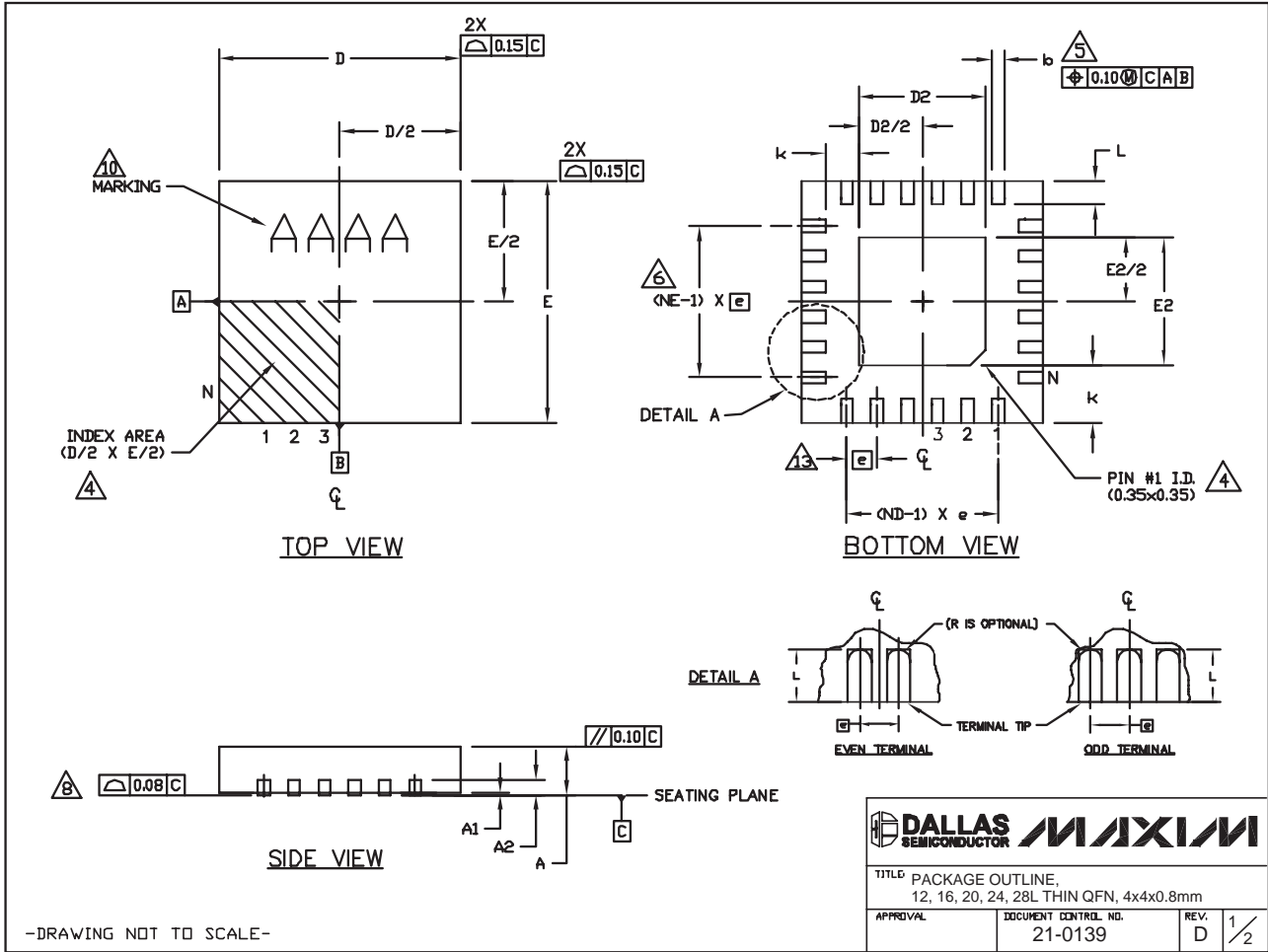

Dual-/Triple-Voltage, Power-Supply Trackers/Sequencers/Supervisors

Package Information (continued)

(The package drawing(s) in this data sheet may not reflect the most current specifications. For the latest package outline information, go to www.maxim-ic.com/packages.)

COMMON DIMENSIONS													EXPOSED PAD VARIATIONS										
PKG REF.	12L 4x4			16L 4x4			20L 4x4			24L 4x4			28L 4x4			PKG CODES	D2			E2			DOWN BONDS ALLOWED
	MIN.	NOM.	MAX.	MIN.	NOM.	MAX.	MIN.	NOM.	MAX.	MIN.	NOM.	MAX.	MIN.	NOM.	MAX.		MIN.	NOM.	MAX.	MIN.	NOM.	MAX.	
A	0.70	0.75	0.80	0.70	0.75	0.80	0.70	0.75	0.80	0.70	0.75	0.80	0.70	0.75	0.80	T1244-2	1.95	2.10	2.25	1.95	2.10	2.25	NO
A1	0.0	0.02	0.05	0.0	0.02	0.05	0.0	0.02	0.05	0.0	0.02	0.05	0.0	0.02	0.05	T1244-3	1.95	2.10	2.25	1.95	2.10	2.25	YES
A2	0.20 REF			0.20 REF			0.20 REF			0.20 REF			0.20 REF			T1244-4	1.95	2.10	2.25	1.95	2.10	2.25	NO
b	0.25	0.30	0.35	0.25	0.30	0.35	0.20	0.25	0.30	0.18	0.23	0.30	0.15	0.20	0.25	T1644-2	1.95	2.10	2.25	1.95	2.10	2.25	NO
D	3.90	4.00	4.10	3.90	4.00	4.10	3.90	4.00	4.10	3.90	4.00	4.10	3.90	4.00	4.10	T1644-3	1.95	2.10	2.25	1.95	2.10	2.25	YES
E	3.90	4.00	4.10	3.90	4.00	4.10	3.90	4.00	4.10	3.90	4.00	4.10	3.90	4.00	4.10	T1644-4	1.95	2.10	2.25	1.95	2.10	2.25	NO
e	0.80 BSC.			0.65 BSC.			0.50 BSC.			0.50 BSC.			0.40 BSC.			T2044-1	1.95	2.10	2.25	1.95	2.10	2.25	NO
K	0.25	-	-	0.25	-	-	0.25	-	-	0.25	-	-	0.25	-	-	T2044-2	1.95	2.10	2.25	1.95	2.10	2.25	YES
L	0.45	0.55	0.65	0.45	0.55	0.65	0.45	0.55	0.65	0.30	0.40	0.50	0.30	0.40	0.50	T2044-3	1.95	2.10	2.25	1.95	2.10	2.25	NO
N	12			16			20			24			28			T2444-1	2.45	2.60	2.63	2.45	2.60	2.63	NO
ND	3			4			5			6			7			T2444-2	1.95	2.10	2.25	1.95	2.10	2.25	YES
NE	3			4			5			6			7			T2444-3	2.45	2.60	2.63	2.45	2.60	2.63	YES
JEDEC VIZ.	VGG3			VGGC			WGGD-1			WGGD-2			WGGE			T2444-4	2.45	2.60	2.63	2.45	2.60	2.63	NO
																T2844-1	2.50	2.60	2.70	2.50	2.60	2.70	NO

NOTES:

- DIMENSIONING & TOLERANCING CONFORM TO ASME Y14.5M-1994.
- ALL DIMENSIONS ARE IN MILLIMETERS. ANGLES ARE IN DEGREES.
- N IS THE TOTAL NUMBER OF TERMINALS.
- THE TERMINAL #1 IDENTIFIER AND TERMINAL NUMBERING CONVENTION SHALL CONFORM TO JEDEC 95-1 SPP-012. DETAILS OF TERMINAL #1 IDENTIFIER ARE OPTIONAL, BUT MUST BE LOCATED WITHIN THE ZONE INDICATED. THE TERMINAL #1 IDENTIFIER MAY BE EITHER A MOLD OR MARKED FEATURE.
- DIMENSION b APPLIES TO METALLIZED TERMINAL AND IS MEASURED BETWEEN 0.25 mm AND 0.30 mm FROM TERMINAL TIP.
- ND AND NE REFER TO THE NUMBER OF TERMINALS ON EACH D AND E SIDE RESPECTIVELY.
- DEPOPULATION IS POSSIBLE IN A SYMMETRICAL FASHION.
- COPLANARITY APPLIES TO THE EXPOSED HEAT SINK SLUG AS WELL AS THE TERMINALS.
- DRAWING CONFORMS TO JEDEC MO220, EXCEPT FOR T2444-1, T2444-3, T2444-4 AND T2844-1.
- MARKING IS FOR PACKAGE ORIENTATION REFERENCE ONLY.
- COPLANARITY SHALL NOT EXCEED 0.08mm
- WARPAGE SHALL NOT EXCEED 0.10mm
- LEAD CENTERLINES TO BE AT TRUE POSITION AS DEFINED BY BASIC DIMENSION "e", ±0.05.

TITLE PACKAGE OUTLINE, 12, 16, 20, 24, 28L THIN QFN, 4x4x0.8mm	
APPROVAL	DOCUMENT CONTROL NO. 21-0139
REV. D	2/2

-DRAWING NOT TO SCALE-

Maxim cannot assume responsibility for use of any circuitry other than circuitry entirely embodied in a Maxim product. No circuit patent licenses are implied. Maxim reserves the right to change the circuitry and specifications without notice at any time.

24 **Maxim Integrated Products, 120 San Gabriel Drive, Sunnyvale, CA 94086 408-737-7600**