



# Ultra-Low-Voltage SC70 Voltage Detectors and $\mu$ P Reset Circuits

MAX6832-MAX6840

## General Description

The MAX6832–MAX6840 are microprocessor ( $\mu$ P) supervisory circuits used to monitor low-voltage power supplies in  $\mu$ P and digital systems. They provide excellent circuit reliability and low cost by eliminating external components and adjustments when used with +1.2V to +1.8V powered circuits.

These devices assert a reset signal whenever the  $V_{CC}$  supply voltage declines below a preset threshold or whenever manual reset ( $\overline{MR}$ ) is asserted. Reset remains asserted for a fixed timeout delay after  $V_{CC}$  has risen above the reset threshold or when manual reset is deasserted. Five different timeout periods are available: 70 $\mu$ s (voltage detector), 1.5ms, 30ms, 210ms, and 1.68s. Reset thresholds suitable for operation with a variety of supply voltages are available.

The MAX6832/MAX6835/MAX6838 have a push-pull active-low reset output ( $\overline{RESET}$ ). The MAX6833/MAX6836/MAX6839 have a push-pull active-high reset output ( $RESET$ ) and the MAX6834/MAX6837/MAX6840 have an open-drain active-low reset output ( $\overline{RESET}$ ). The open-drain active-low reset output requires a pullup resistor that can be connected to a voltage higher than  $V_{CC}$ .

The MAX6835/MAX6836/MAX6837 feature a debounced manual reset input ( $\overline{MR}$ ), while the MAX6838/MAX6839/MAX6840 provide a  $RESET-IN$  input allowing the user to externally adjust the reset threshold. The reset comparator is designed to ignore fast transients on  $V_{CC}$ .

Low supply current of 7.5 $\mu$ A makes the MAX6832–MAX6840 ideal for use in portable equipment. These devices are available in 3- and 4-pin SC70 packages.

## Applications

Computers  
 Controllers  
 Intelligent Instruments  
 Critical  $\mu$ P and  $\mu$ C Power Monitoring  
 Portable/Battery-Powered Equipment

**Pin Configurations appear at end of data sheet.**

**Typical Operating Circuit appears at end of data sheet.**

**Selector Guide appears at end of data sheet.**

## Features

- ◆ Factory-Set Reset Threshold Voltages for Nominal Supplies from 1.2V to 1.8V
- ◆ Low Power Consumption: 7.5 $\mu$ A (typ)
- ◆ Space-Saving 3- and 4-Pin SC70 Packages
- ◆  $\pm 2.5\%$  Reset Threshold Accuracy Over Temperature
- ◆ Five Different Timeout Periods Available: 70 $\mu$ s (voltage detector), 1.5ms, 30ms, 210ms, and 1.68s
- ◆ Three Reset Output Configurations  
     Push-Pull  $\overline{RESET}$   
     Push-Pull  $RESET$   
     Open-Drain  $\overline{RESET}$
- ◆ Guaranteed Reset Valid to  $V_{CC} =$   
     0.55V—Active-Low  
     0.75V—Active-High
- ◆ Adjustable Threshold Reset-In Option
- ◆ Manual Reset Input Option
- ◆ Immune to Short Negative  $V_{CC}$  Transients
- ◆ Pin Compatible with MAX803/MAX809/MAX810, MAX6711/MAX6712/MAX6713, and MAX6381–MAX6390 Series

## Ordering Information

PART	TEMP. RANGE	PIN-PACKAGE
MAX6832_XRD_-T	-40°C to +85°C	3 SC70-3
MAX6833_XRD_-T	-40°C to +85°C	3 SC70-3
MAX6834_XRD_-T	-40°C to +85°C	3 SC70-3
MAX6835_XSD_-T	-40°C to +85°C	4 SC70-4
MAX6836_XSD_-T	-40°C to +85°C	4 SC70-4
MAX6837_XSD_-T	-40°C to +85°C	4 SC70-4
MAX6838XSD_-T	-40°C to +85°C	4 SC70-4
MAX6839XSD_-T	-40°C to +85°C	4 SC70-4
MAX6840XSD_-T	-40°C to +85°C	4 SC70-4

Insert the desired suffix letter from the Threshold Suffix Guide (MAX6832–MAX6837) and the Active Timeout Period Guide tables into the blanks to complete the part number. Sample stock is generally available on standard versions only (see Standard Versions table). Standard versions require a minimum order increment of 2.5k units. Nonstandard versions must be ordered in 10k unit increments. Contact factory for availability. All parts are offered in tape-and-reel only.



# Ultra-Low-Voltage SC70 Voltage Detectors and $\mu$ P Reset Circuits

## ABSOLUTE MAXIMUM RATINGS

Terminal Voltage (with respect to GND)		Continuous Power Dissipation ( $T_A = +70^\circ\text{C}$ )	
$V_{CC}$ .....	-0.3V to +6.0V	3-Pin SC70 (derate 2.9mW/ $^\circ\text{C}$ above +70 $^\circ\text{C}$ ) .....	235mW
Open-Drain RESET, MR .....	-0.3V to +6.0V	4-Pin SC70 (derate 3.1mW/ $^\circ\text{C}$ above +70 $^\circ\text{C}$ ) .....	245mW
RESET-IN, Push-Pull RESET		Operating Temperature Range .....	-40 $^\circ\text{C}$ to +85 $^\circ\text{C}$
and RESET .....	-0.3V to ( $V_{CC} + 0.3\text{V}$ )	Junction Temperature .....	+150 $^\circ\text{C}$
Input/Output Current (all pins) .....	20mA	Storage Temperature Range .....	-65 $^\circ\text{C}$ to +150 $^\circ\text{C}$
		Lead Temperature (soldering, 10s) .....	+300 $^\circ\text{C}$

Stresses beyond those listed under "Absolute Maximum Ratings" may cause permanent damage to the device. These are stress ratings only, and functional operation of the device at these or any other conditions beyond those indicated in the operational sections of the specifications is not implied. Exposure to absolute maximum rating conditions for extended periods may affect device reliability.

## ELECTRICAL CHARACTERISTICS

( $V_{CC} = +0.55\text{V}$  to +3.6V,  $T_A = T_{MIN}$  to  $T_{MAX}$ , unless otherwise noted. Typical values are at  $T_A = +25^\circ\text{C}$ .) (Note 1)

PARAMETER	SYMBOL	CONDITIONS	MIN	TYP	MAX	UNITS
Supply Voltage Range	$V_{CC}$	$T_A = -40^\circ\text{C}$ to +85 $^\circ\text{C}$ MAX6832/MAX6835/MAX6838 MAX6834/MAX6837/MAX6840	0.55		3.6	V
		$T_A = -40^\circ\text{C}$ to +85 $^\circ\text{C}$ MAX6833/MAX6836/MAX6839	0.85		3.6	
		$T_A = 0^\circ\text{C}$ to +85 $^\circ\text{C}$ MAX6833/MAX6836/MAX6839	0.75		3.6	
Supply Current	$I_{CC}$	$V_{CC} = 1.2\text{V}$ , no load, reset not asserted		7.5	13	$\mu\text{A}$
		$V_{CC} = 1.8\text{V}$ , no load, reset not asserted		9	16	
		$V_{CC} = 3.6\text{V}$ , no load, reset not asserted		16	25	
Reset Threshold	$V_{TH}$	W	1.620	1.665	1.710	V
		V	1.530	1.575	1.620	
		I	1.350	1.388	1.425	
		H	1.275	1.313	1.350	
		G	1.080	1.110	1.140	
RESET-IN Threshold	$V_{RSTIN}$	$1.1\text{V} \leq V_{CC} \leq 3.3\text{V}$ , 0 $^\circ\text{C}$ to +85 $^\circ\text{C}$	-2.5%	444	+2.5%	mV
		$1.1\text{V} \leq V_{CC} \leq 3.3\text{V}$ , -40 $^\circ\text{C}$ to +85 $^\circ\text{C}$	-3.0%	444	+3.0%	
RESET-IN Leakage Current	$I_{RSTIN}$		-25		+25	nA
Reset Threshold Hysteresis	$V_{HYS}$			0.75		% $V_{TH}$
$V_{CC}$ or RESET-IN to Reset Delay		$V_{CC}$ falling, step signal from ( $V_{TH} + 100\text{mV}$ ) to ( $V_{TH} - 100\text{mV}$ )		60		$\mu\text{s}$
Reset Active Timeout Period	$t_{RP}$	D0		0.07		ms
		D1	1	1.5	2	
		D2	20	30	40	
		D3	140	210	280	
		D4	1120	1680	2240	

# Ultra-Low-Voltage SC70 Voltage Detectors and $\mu$ P Reset Circuits

MAX6832-MAX6840

## ELECTRICAL CHARACTERISTICS (continued)

( $V_{CC} = +0.55V$  to  $+3.6V$ ,  $T_A = T_{MIN}$  to  $T_{MAX}$ , unless otherwise noted. Typical values are at  $T_A = +25^\circ C$ .) (Note 1)

PARAMETER	SYMBOL	CONDITIONS	MIN	TYP	MAX	UNITS
Propagation Delay (D0 only)	$t_P$	$V_{CC}$ rising, step signal from ( $V_{TH} - 100mV$ ) to ( $V_{TH} + 100mV$ )		70		$\mu s$
Startup Time (D0 only)		$V_{CC}$ rising from 0 to 1.1V ( $t_R < 1\mu s$ )		150		$\mu s$
$\overline{MR}$ Input Voltage	$V_{IL}$			0.3 x $V_{CC}$		V
	$V_{IH}$		0.7 x $V_{CC}$			
$\overline{MR}$ Minimum Input Pulse Width		$\overline{MR}$ driven from $V_{CC}$ to 0	2			$\mu s$
$\overline{MR}$ Glitch Rejection		$\overline{MR}$ driven from $V_{CC}$ to 0		100		ns
$\overline{MR}$ to Reset Delay		$\overline{MR}$ driven from $V_{CC}$ to 0		500		ns
$\overline{MR}$ Pullup Resistance To $V_{CC}$			14	20	26	$k\Omega$
Open-Drain $\overline{RESET}$ Output Voltage	$V_{OL}$	$V_{CC} \geq 0.55V$ , $I_{SINK} = 15\mu A$ , reset asserted			0.15	V
		$V_{CC} \geq 1.0V$ , $I_{SINK} = 80\mu A$ , reset asserted			0.15	
		$V_{CC} \geq 1.5V$ , $I_{SINK} = 200\mu A$ , reset asserted			0.2	
Open-Drain $\overline{RESET}$ Output Leakage Current	$I_{LKG}$	$V_{CC} > V_{TH}$ , reset not asserted			1.0	$\mu A$
Push-Pull $\overline{RESET}$ Output Voltage	$V_{OL}$	$V_{CC} \geq 0.55V$ , $I_{SINK} = 15\mu A$ , reset asserted		0.2 x $V_{CC}$		V
		$V_{CC} \geq 1.0V$ , $I_{SINK} = 80\mu A$ , reset asserted		0.2 x $V_{CC}$		
		$V_{CC} \geq 1.5V$ , $I_{SINK} = 200\mu A$ , reset asserted		0.2 x $V_{CC}$		
	$V_{OH}$	$V_{CC} \geq 1.1V$ , $I_{SOURCE} = 50\mu A$ , reset not asserted	0.8 x $V_{CC}$			
		$V_{CC} \geq 1.5V$ , $I_{SOURCE} = 150\mu A$ , reset asserted	0.8 x $V_{CC}$			
Push-Pull $\overline{RESET}$ Output Voltage	$V_{OH}$	$V_{CC} \geq 0.75V$ , $I_{SOURCE} = 10\mu A$ , reset asserted (Note 2)	0.8 x $V_{CC}$			
		$V_{CC} \geq 0.85V$ , $I_{SOURCE} = 10\mu A$ , reset asserted	0.8 x $V_{CC}$			
		$V_{CC} \geq 1.0V$ , $I_{SOURCE} = 50\mu A$ , reset asserted	0.8 x $V_{CC}$			
		$V_{CC} \geq 1.5V$ , $I_{SOURCE} = 150\mu A$ , reset asserted	0.8 x $V_{CC}$			
	$V_{OL}$	$V_{CC} \geq 1.1V$ , $I_{SINK} = 80\mu A$ , reset not asserted		0.2 x $V_{CC}$		
		$V_{CC} \geq 1.5V$ , $I_{SINK} = 200\mu A$ , reset not asserted		0.2 x $V_{CC}$		

**Note 1:** 100% production tested at  $+25^\circ C$ . Over temperature limits are guaranteed by design.

**Note 2:** Temperature range is from  $0^\circ C$  to  $+85^\circ C$ .

# Ultra-Low-Voltage SC70 Voltage Detectors and $\mu P$ Reset Circuits

## Typical Operating Characteristics

( $V_{CC}$  = full range and  $T_A$  =  $-40^\circ C$  to  $+85^\circ C$ , unless otherwise noted. Typical values are at  $T_A$  =  $+25^\circ C$ ).

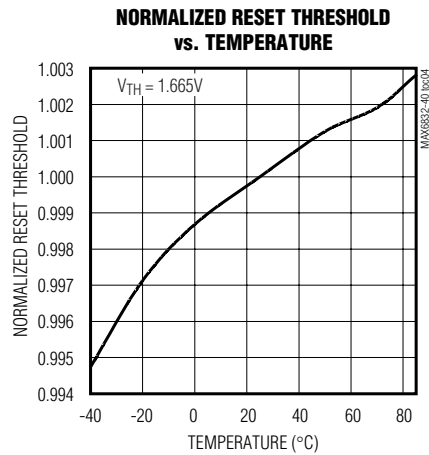
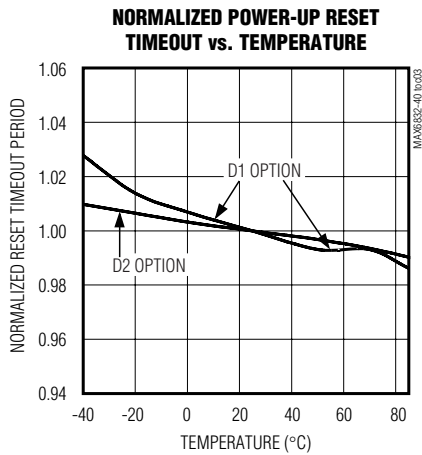
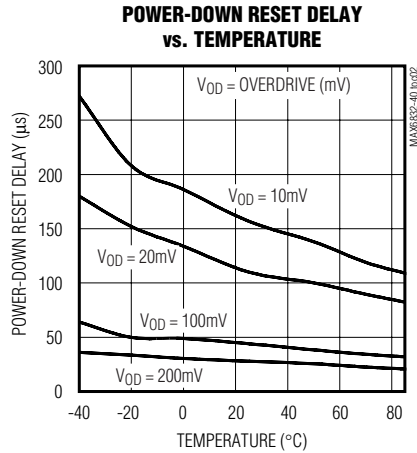
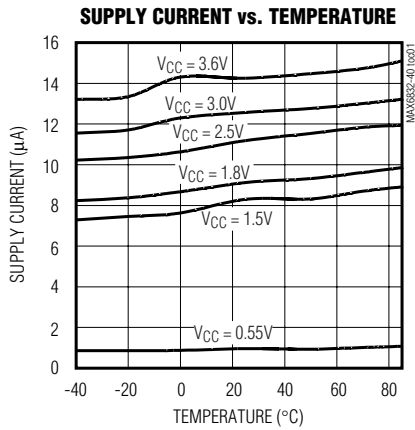

# Ultra-Low-Voltage SC70 Voltage Detectors and $\mu$ P Reset Circuits

## Pin Description—MAX6832–MAX6837

**MAX6832–MAX6840**

PIN				NAME	FUNCTION
MAX6833 SC70-3	MAX6832/ MAX6834 SC70-3	MAX6836 SC70-4	MAX6835/ MAX6837 SC70-4		
1	1	1	1	GND	Ground
—	2	—	2	$\overline{\text{RESET}}$	Reset Output, Open-Drain or Push-Pull, Active-Low. $\overline{\text{RESET}}$ changes from HIGH to LOW when $V_{CC}$ drops below the selected reset threshold or $\overline{\text{MR}}$ is pulled low. $\overline{\text{RESET}}$ remains LOW for the reset timeout period after $V_{CC}$ exceeds the device reset threshold and $\overline{\text{MR}}$ is released high.
2	—	2	—	RESET	Reset Output, Push-Pull, Active-High. RESET changes from LOW to HIGH when the $V_{CC}$ input drops below the selected reset threshold or $\overline{\text{MR}}$ is pulled low. RESET remains HIGH for the reset timeout period after $V_{CC}$ exceeds the device reset threshold and $\overline{\text{MR}}$ is released high.
—	—	3	3	$\overline{\text{MR}}$	Active-Low Manual Reset Input. Internal 20k $\Omega$ pullup to $V_{CC}$ . Pull LOW to force a reset. Reset remains active as long as $\overline{\text{MR}}$ is LOW and for the reset timeout period after $\overline{\text{MR}}$ goes HIGH. Leave unconnected or connect to $V_{CC}$ if unused.
3	3	4	4	$V_{CC}$	Supply Voltage and Monitored Supply

## Pin Description—MAX6838/MAX6839/MAX6840

PIN		NAME	FUNCTION
MAX6839 SC70-4	MAX6838/ MAX6840 SC70-4		
1	1	RESET-IN	Adjustable Reset Threshold Input. High-impedance input for reset comparator. Connect this pin to an external resistive-divider network to set the reset threshold voltage; the typical threshold is 444mV. Reset is asserted when RESET-IN is below the threshold ( $V_{CC}$ is not monitored).
2	2	$V_{CC}$	Supply Voltage (1.1V to 3.3V)
3	3	GND	Ground
4	—	RESET	Reset Output, Push-Pull, Active-High. RESET changes from LOW to HIGH when the RESET-IN input drops below the typical reset threshold (444mV). RESET remains HIGH for the reset timeout period after RESET-IN exceeds the reset threshold.
—	4	$\overline{\text{RESET}}$	Reset Output, Open-Drain or Push-Pull, Active-Low. $\overline{\text{RESET}}$ changes from HIGH to LOW when RESET-IN drops below the typical reset threshold (444mV). $\overline{\text{RESET}}$ remains LOW for the reset timeout period after RESET-IN exceeds the reset threshold.

# Ultra-Low-Voltage SC70 Voltage Detectors and $\mu$ P Reset Circuits

## Functional Diagrams

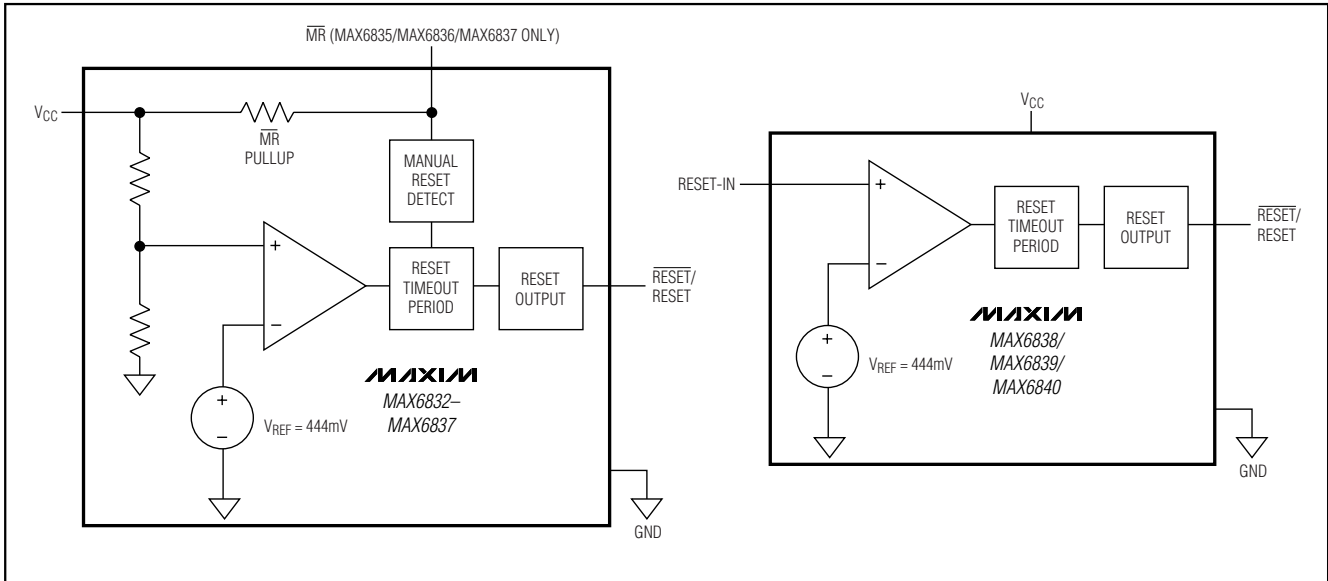

## Detailed Description

### Reset Output

A microprocessor's ( $\mu$ P's) reset input starts the  $\mu$ P in a known state. The MAX6832-MAX6840 assert a reset to prevent code-execution errors during power-up, power-down, or brownout conditions. They also assert a reset signal whenever the  $V_{CC}$  supply voltage falls below a preset threshold (MAX6832-MAX6837) or RESET-IN falls below the adjustable threshold (MAX6838/MAX6839/MAX6840), keeping reset asserted for a fixed timeout delay (Table 2) after  $V_{CC}$  or RESET-IN has risen above the reset threshold. The MAX6832/MAX6835/MAX6838 use a push-pull active-low output, the MAX6833/MAX6836/MAX6839 have a push-pull active-high output, and the MAX6834/MAX6837/MAX6840 have an open-drain active-low output stage. Connect a pullup resistor on the MAX6834/MAX6837/MAX6840's RESET output to any supply between 0 and 6V.

### Manual Reset Input

Many  $\mu$ P-based systems require manual reset capability, allowing the operator, a test technician, or external logic circuitry to initiate a reset. Reset remains asserted while  $\overline{MR}$  is low, and for a fixed timeout delay after  $\overline{MR}$  returns high. This input has an internal  $20k\Omega$  pullup resistor, so it can be left open if it is not used.  $\overline{MR}$  can be driven with CMOS logic level, or with open-drain/collector outputs. To create a manual reset function, connect a normally open momentary switch from  $\overline{MR}$  to ground; external debounce circuitry is not required. If

$\overline{MR}$  is driven from long cables or if the device is used in a noisy environment, connecting a  $0.1\mu F$  capacitor from  $\overline{MR}$  to ground provides additional noise immunity.

### RESET-IN Information

The MAX6838/MAX6839/MAX6840 feature a RESET-IN input for monitoring supply voltages down to 0.44V. An external resistive-divider network can be used to set voltage monitoring thresholds as shown in Figure 1. As the monitored voltage falls, the voltage at RESET-IN decreases and asserts a reset when it falls below the RESET-IN threshold ( $V_{RSTIN}$ ). The low-leakage current

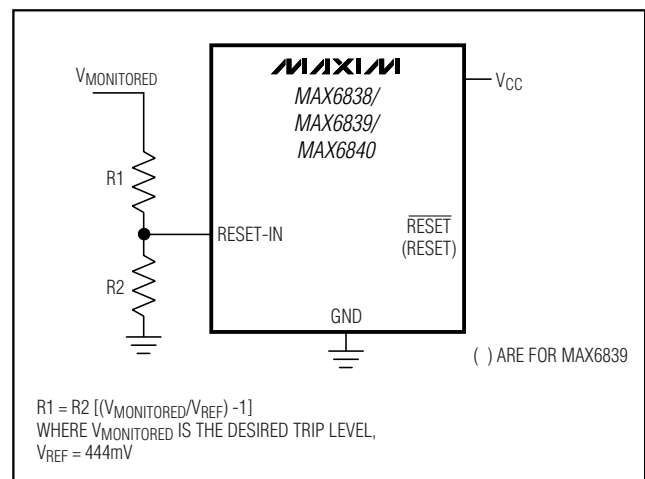

Figure 1. Setting the Adjustable Threshold Externally

# Ultra-Low-Voltage SC70 Voltage Detectors and $\mu\text{P}$ Reset Circuits

MAX6832-MAX6840

at RESET-IN allows for relatively large-value resistors to be used, which reduce power consumption. For example, for a 0.6V monitored trip level, if  $R_2 = 200\text{k}\Omega$ , then  $R_1 = 70.3\text{k}\Omega$ . Note that the minimum  $V_{CC}$  of 1.1V is required to guarantee the RESET-IN threshold accuracy (see *Electrical Characteristics* table).

## Applications Information

### Negative-Going $V_{CC}$ Transients

In addition to issuing a reset to the  $\mu\text{P}$  during power-up, power-down, and brownout conditions, the MAX6832-MAX6840 are relatively immune to short-duration negative-going  $V_{CC}$  transients (glitches).

Figure 2 shows typical transient duration vs. reset comparator overdrive, for which the MAX6832-MAX6840 do **not** generate a reset pulse. The graph was generated using a negative-going pulse applied to  $V_{CC}$ , starting 0.1V above the actual reset threshold and ending below it by the magnitude indicated (reset comparator overdrive). The graph indicates the maximum pulse width a negative-going  $V_{CC}$  transient can have without causing a reset pulse. As the magnitude of the transient increases (goes farther below the reset threshold), the maximum allowable pulse width decreases. A 0.1 $\mu\text{F}$  bypass capacitor mounted as close as possible to the  $V_{CC}$  pin provides additional transient immunity.

### Ensuring a Valid Reset Output Down to $V_{CC} = 0$

When  $V_{CC}$  falls below 0.55V, the MAX6832/MAX6835/MAX6838 push-pull RESET output no longer sinks current—it becomes an open circuit. Therefore, high-impedance CMOS logic inputs connected to RESET

can drift to undetermined voltages. This presents no problem in most applications since most  $\mu\text{P}$  and other circuitry are inoperative with  $V_{CC}$  lower than 0.55V. However, in applications where RESET must be valid down to 0, adding a pull-down resistor to RESET causes any stray leakage currents to flow to ground, holding RESET low (Figure 3).  $R_3$ 's value is not critical; 100k $\Omega$  is large enough not to load RESET and small enough to pull RESET to ground.

A 100k $\Omega$  pullup resistor to  $V_{CC}$  is also recommended for the MAX6833/MAX6836/MAX6839 if RESET is required to remain valid for  $V_{CC} < 0.85\text{V}$ .

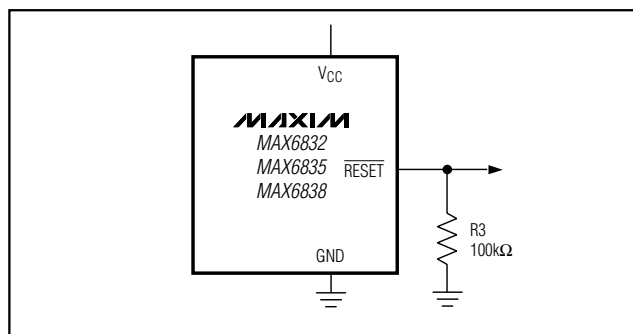

Figure 3. RESET Valid to  $V_{CC} = \text{Ground}$  Circuit

### Interfacing to $\mu\text{P}$ s with Bidirectional Reset Pins

Since the RESET output on the MAX6834/MAX6837/MAX6840 is open-drain, these devices interface easily with  $\mu\text{P}$ s that have bidirectional reset pins. Connecting the  $\mu\text{P}$  supervisor's RESET output directly to the  $\mu\text{P}$ 's RESET pin with a single pullup resistor allows either device to assert a reset (Figure 4).

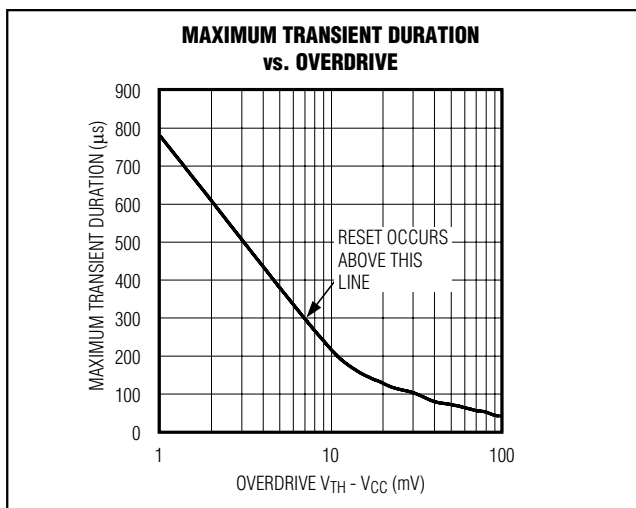

Figure 2. Maximum Transient Duration Without Causing a Reset Pulse vs. Reset Comparator Overdrive

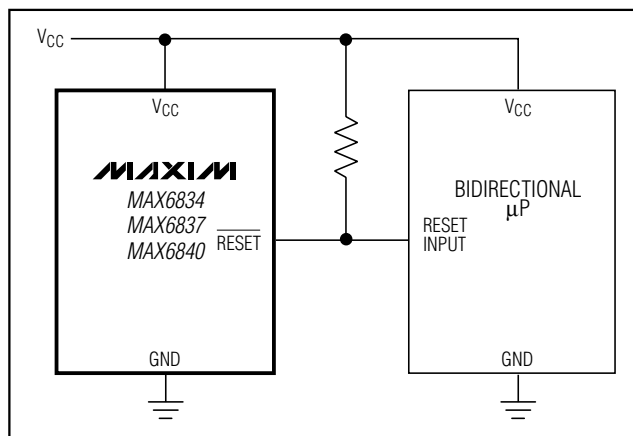

Figure 4. Interfacing to  $\mu\text{P}$ s with Bidirectional Reset I/O

# Ultra-Low-Voltage SC70 Voltage Detectors and $\mu$ P Reset Circuits

## Using The MAX6834/MAX6837/MAX6840 Open-Drain RESET Output with Multiple Supplies

Generally, the pullup connected to the MAX6834/MAX6837/MAX6840 will connect to the supply voltage that is being monitored at the IC's VCC pin. However, some systems may use the open-drain output to level-shift from the monitored supply to reset circuitry powered by some other supply (Figure 5). Note that as the MAX6834/MAX6837/MAX6840's VCC decreases, so does the IC's ability to sink current at RESET. Also, with any pullup, RESET will be pulled high as VCC declines toward 0. The voltage where this occurs depends on the pullup resistor value and the voltage to which it is connected.

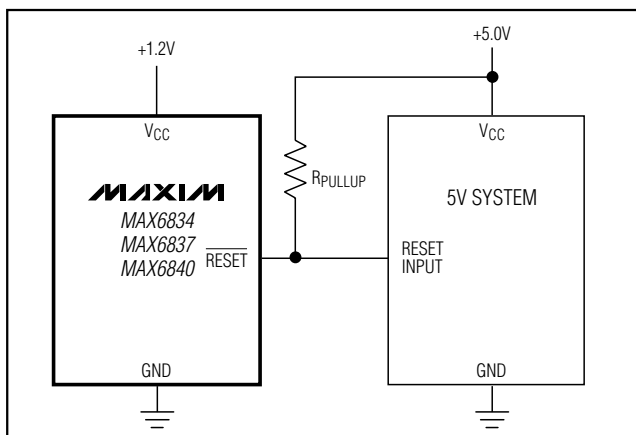

Figure 5. Using The MAX6834/MAX6837/MAX6840 Open-Drain RESET Output with Multiple Supplies

## Chip Information

TRANSISTOR COUNT: 681

PROCESS: BiCMOS

## Selector Guide

Table 1. Threshold Suffix Guide

SUFFIX	RESET THRESHOLD (V)
W	1.665
V	1.575
I	1.388
H	1.313
G	1.110
F	1.050

Table 2. Active Timeout Period Guide

SUFFIX	TYPICAL RESET ACTIVE TIMEOUT PERIOD (ms)
D0	0.07
D1	1.5
D2	30
D3	210
D4	1680

Table 3. Standard Versions

DEVICE	TOP MARK
MAX6832VXR00	AIQ
MAX6832VXR03	AIR
MAX6832HXR00	AIS
MAX6832HXR03	AIT
MAX6832FXR00	AIU
MAX6832FXR03	AIV
MAX6833VXR00	AHJ
MAX6833VXR03	AIW
MAX6833HXR00	AIX
MAX6833HXR03	AIY
MAX6833FXR00	AIZ
MAX6833FXR03	AJA
MAX6834VXR00	AJB
MAX6834VXR03	AJC
MAX6834HXR00	AJD
MAX6834HXR03	AJE
MAX6834FXR00	AJF
MAX6834FXR03	AJG
MAX6835VXS00	AEX



# Ultra-Low-Voltage SC70 Voltage Detectors and $\mu$ P Reset Circuits

## Pin Configurations

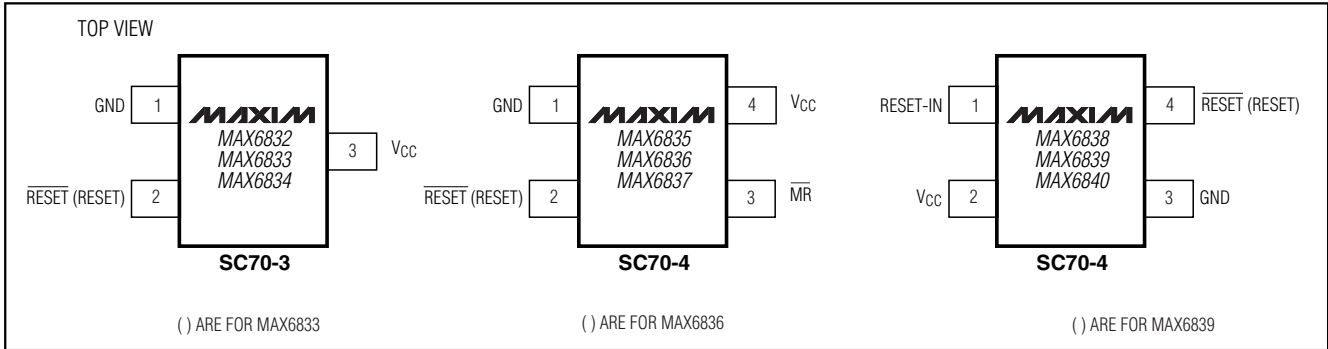

## Typical Operating Circuit

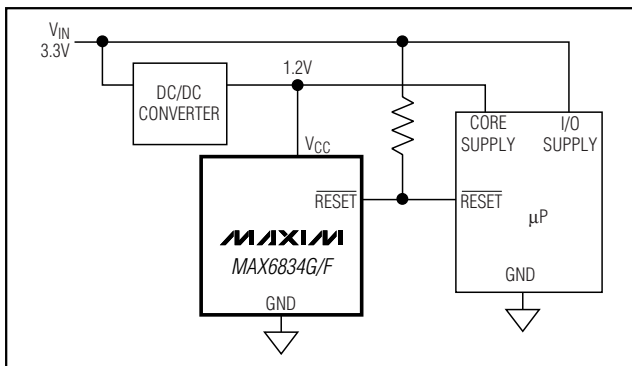

## Selector Guide (continued)

Table 3. Standard Versions (continued)

DEVICE	TOP MARK
MAX6835VXSD3	AFF
MAX6835HXSD0	AFG
MAX6835HXSD3	AFH
MAX6835FXSD0	AFI
MAX6835FXSD3	AFJ
MAX6836VXSD0	AFK
MAX6836VXSD3	AFL
MAX6836HXSD0	AFM
MAX6836HXSD3	AFN
MAX6836FXSD0	AFO
MAX6836FXSD3	AFP
MAX6837VXSD0	AFQ
MAX6837VXSD3	AFR
MAX6837HXSD0	AFS
MAX6837HXSD3	AFT
MAX6837FXSD0	AFU
MAX6837FXSD3	AFC
MAX6838XSD0	AFW
MAX6838XSD3	AFV
MAX6839XSD0	AFX
MAX6839XSD3	AEZ
MAX6840XSD0	AFY
MAX6840XSD3	AFZ

MAX6832-MAX6840

# Ultra-Low-Voltage SC70 Voltage Detectors and $\mu$ P Reset Circuits

## Package Information

SYMBOL	MIN	MAX
e	0.65	BSC
D	1.80	2.20
b	0.25	0.40
E	1.15	1.35
HE	1.80	2.40
Q1	0.10	0.40
A2	0.80	1.00
A1	0.00	0.10
A	0.80	1.10
c	0.10	0.18
L	0.10	0.30
L1	0.425	TYP.

NOTE:

1. ALL DIMENSIONS ARE IN MILLIMETERS
2. DIMENSIONS ARE INCLUSIVE OF PLATING
3. DIMENSIONS ARE EXCLUSIVE OF MOLD FLASH & METAL BURR
4. ALL SPECIFICATIONS COMPLY TO EIAJ SC70
5. COPLANARITY 4 MILS. MAX.

MAXIM  
PROPRIETARY INFORMATION  
 TITLE:  
 PACKAGE OUTLINE, SC70, 3L  
 APPROVAL: \_\_\_\_\_ DOCUMENT CONTROL NO. 21-0075 REV B 1/1

SC70, 3L-EPS

# Ultra-Low-Voltage SC70 Voltage Detectors and $\mu$ P Reset Circuits

## Package Information (continued)

**MAX6832-MAX6840**

SC70, 4L EPS

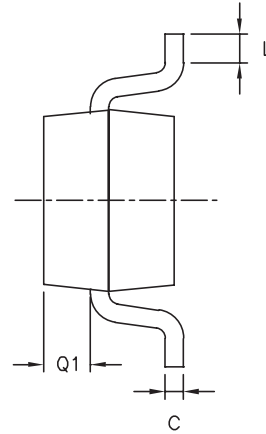
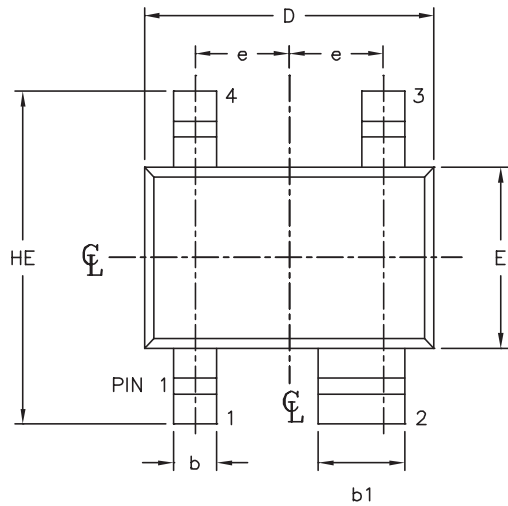

SYMBOL	MIN	MAX
e	0.65	BSC
D	1.80	2.25
b	0.15	0.40
b1	0.55	0.70
E	1.15	1.35
HE	1.80	2.40
Q1	0.10	0.40
A2	0.80	1.00
A1	0.00	0.10
A	0.80	1.10
c	0.10	0.18
L	0.10	0.30

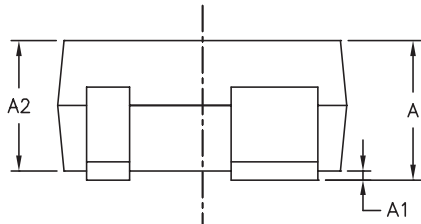

**NOTE:**

1. ALL DIMENSIONS ARE IN MILLIMETERS.
2. DIMENSIONS ARE INCLUSIVE OF PLATING.
3. DIMENSIONS ARE EXCLUSIVE OF MOLD FLASH & METAL BURR.
4. ALL SPECIFICATIONS COMPLY TO EIAJ SC70.
5. DIE IS FACING UP FOR MOLD AND FACING DOWN FOR TRIM/FORM. ie: REVERSE TRIM/FORM.
6. PACKAGE SURFACE TO BE MIRROR FINISH.

<b>MAXIM</b>		
<small>PROPRIETARY INFORMATION</small>		
<small>TITLE:</small>		
PACKAGE OUTLINE, SC70, 4L		
<small>APPROVAL</small>	<small>DOCUMENT CONTROL NO.</small>	<small>REV</small>
	21-0098	A 1/1

Maxim cannot assume responsibility for use of any circuitry other than circuitry entirely embodied in a Maxim product. No circuit patent licenses are implied. Maxim reserves the right to change the circuitry and specifications without notice at any time.

**Maxim Integrated Products, 120 San Gabriel Drive, Sunnyvale, CA 94086 408-737-7600** \_\_\_\_\_ 11