

**MAXIM**

# Quad Voltage $\mu$ P Supervisory Circuit in SOT Package

**MAX6339**

## General Description

The MAX6339 is a precision quad voltage monitor with microprocessor ( $\mu$ P) supervisory reset timing. The device can monitor up to four system supply voltages without any external components and asserts a single reset if any supply voltage drops below its preset threshold. The device significantly reduces system size and component count while improving reliability compared to separate ICs or discrete components.

A variety of factory-trimmed threshold voltages are available to accommodate different supply voltages and tolerances with minimal external component requirements. The selection includes internally fixed options for monitoring +5.0V, +3.3V, +3.0V, +2.5V, +1.8V, and -5.0V supplies with -5% and/or -10% tolerances. The device is also available with one or two user-adjustable threshold options if non-standard thresholds are desired (use external resistor-divider network).

The quad monitor provides a single active-low reset output that is asserted when any monitored input is below its associated threshold. The output is open drain with a weak internal pull-up (10 $\mu$ A) to IN2. Reset remains low for a reset timeout period (140ms min) after all voltages are above the selected thresholds. The output is valid as long as either the IN1 or IN2 input voltage remains >1V.

The MAX6339 is available in a small 6-pin SOT23 package and operates over the extended (-40°C to +85°C) temperature range.

## Applications

Telecommunications  
High-End Printers  
Desktop and Network Computers  
Data Storage Equipment  
Networking Equipment  
Industrial Equipment  
Set-Top Boxes

Pin Configuration appears at end of data sheet.

## Features

- ◆ Monitors Four Power-Supply Voltages
- ◆ Precision Factory-Set Reset Threshold Options for +5.0V, +3.3V, +3.0, +2.5V, +1.8V, and -5.0V Supplies
- ◆ User-Adjustable Voltage Monitoring Threshold Options
- ◆ Low 55 $\mu$ A Supply Current
- ◆ Open-Drain  $\overline{\text{RESET}}$  Output with 10 $\mu$ A Internal Pullup
- ◆ 140ms (min) Reset Timeout Period
- ◆  $\overline{\text{RESET}}$  Valid to IN1 = 1V or IN2 = 1V
- ◆ Immune to Short Monitored Supply Transients
- ◆ No External Components Required
- ◆ Guaranteed from -40°C to +85°C
- ◆ Small 6-Pin SOT23 Package

## Ordering Information

PART	TEMP. RANGE	PIN-PACKAGE
MAX6339_UT-T*	-40°C TO +85°C	6 SOT23-6

\*Insert the desired letter from the Selector Guide into the blank to complete the part number. There is a 2500 piece minimum order increment requirement on the SOT package and these devices are available in tape-and-reel only.

## Typical Operating Circuit

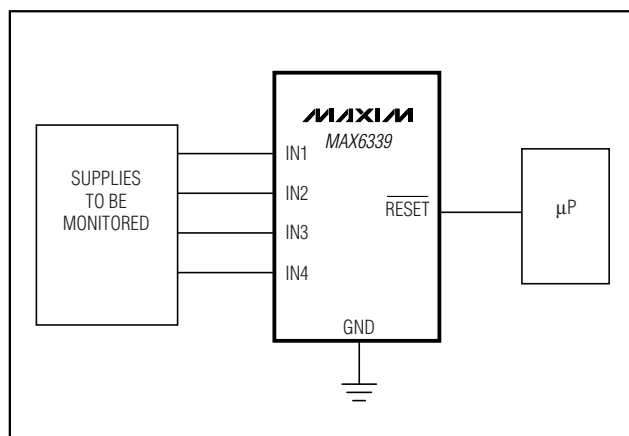
**MAXIM**

Maxim Integrated Products 1

For pricing, delivery, and ordering information, please contact Maxim/Dallas Direct! at 1-888-629-4642, or visit Maxim's website at [www.maxim-ic.com](http://www.maxim-ic.com).

# Quad Voltage $\mu$ P Supervisory Circuit in SOT Package

## ABSOLUTE MAXIMUM RATINGS

Terminal Voltage (with respect to GND)

Input Voltages (IN<sub>-</sub>) (except -5V) .....-0.3V to +6V

RESET .....-0.3V to +6V

Input Voltage (-5V Input) .....-6V to +0.3V

Continuous RESET Current .....20mA

Continuous Power Dissipation (T<sub>A</sub> = +70°C)

6-pin SOT23 (derate 8.7mW/°C above +70°C) .....695.7mW

Operating Temperature Range .....-40°C to +85°C

Storage Temperature Range .....-65°C to +150°C

Junction Temperature .....+150°C

Lead Temperature (soldering, 10s) .....+300°C

Stresses beyond those listed under "Absolute Maximum Ratings" may cause permanent damage to the device. These are stress ratings only, and functional operation of the device at these or any other conditions beyond those indicated in the operational sections of the specifications is not implied. Exposure to absolute maximum rating conditions for extended periods may affect device reliability.

## ELECTRICAL CHARACTERISTICS

(V<sub>IN2</sub> = +1V to +5.5V, T<sub>A</sub> = -40°C to +85°C, unless otherwise noted. Typical values are at V<sub>IN2</sub> = +3.0V to +3.3V, T<sub>A</sub> = +25°C, unless otherwise noted.) (Note 1)

PARAMETER	SYMBOL	CONDITIONS	MIN	TYP	MAX	UNITS	
Supply Voltage Range (Notes 2, 3)	V <sub>IN2</sub>		1.0		5.5	V	
Input Current	I <sub>IN-</sub>	V <sub>IN-</sub> = input threshold voltage (input threshold voltage of 1.8V, 2.5V, 5V)		25	40	$\mu$ A	
		V <sub>IN2</sub> = input threshold voltage (input threshold voltage of 3.0V, 3.3V) (Note 4)		55	115		
		V <sub>IN-</sub> = 0 to V <sub>IN2</sub> (input threshold voltage = +1.23V)		-0.1	0.1		
		V <sub>IN1</sub> = 1.5V (MAX6339 K/L only)			0.4		1.5
		V <sub>IN-</sub> = -5V (input threshold voltage = -5V)			-15		-20
Reset Threshold Voltage	V <sub>TH</sub>	V <sub>IN-</sub> decreasing	+5V (-5%) threshold	4.50	4.63	4.75	V
			+5V (-10%) threshold	4.25	4.38	4.50	
			+3.3V (-5%) threshold	3.00	3.08	3.15	
			+3.3V (-10%) threshold	2.85	2.93	3.00	
			+3.0V (-5%) threshold	2.70	2.78	2.85	
			+3.0V (-10%) threshold	2.55	2.63	2.70	
			+2.5V (-10%) threshold	2.13	2.19	2.25	
		+1.8V (-10%) threshold	1.53	1.58	1.62		
		V <sub>IN-</sub> increasing	-5V (+5%) threshold	-4.75	-4.63	-4.50	
			-5V (+10%) threshold	-4.50	-4.38	-4.25	
Adjustable Threshold	V <sub>TH</sub>	V <sub>IN</sub> decreasing	1.20	1.23	1.26	V	
Threshold Voltage Temperature Coefficient				60		ppm/°C	
Threshold Hysteresis	V <sub>HYST</sub>			0.3		%	
Reset Delay	t <sub>RD</sub>	V <sub>IN</sub> = V <sub>TH</sub> to (V <sub>TH</sub> - 50mV) (all inputs except -5V) or V <sub>IN-</sub> = V <sub>TH</sub> to (V <sub>TH</sub> + 50mV) (-5V input only)		20		$\mu$ s	
Reset Active Timeout Period	t <sub>RP</sub>		140	200	280	ms	

# Quad Voltage $\mu$ P Supervisory Circuit in SOT Package

MAX6339

## ELECTRICAL CHARACTERISTICS (continued)

( $V_{IN2} = +1V$  to  $+5.5V$ ,  $T_A = -40^\circ C$  to  $+85^\circ C$ , unless otherwise noted. Typical values are at  $V_{IN2} = +3.0V$  to  $+3.3V$ ,  $T_A = +25^\circ C$ , unless otherwise noted.) (Note 1)

PARAMETER	SYMBOL	CONDITIONS	MIN	TYP	MAX	UNITS
Output Low Voltage	$V_{OL}$	$V_{IN2} = 5V$ , $I_{SINK} = 2mA$			0.4	V
		$V_{IN2} = 2.5V$ , $I_{SINK} = 1.2mA$			0.4	
		$V_{IN1} = V_{IN2} = 1V$ , $I_{SINK} = 50\mu A$			0.4	
Output High Voltage Output High Source Current	$V_{OH}$	$V_{IN2} > 2.55V$ , $I_{SOURCE} = 6\mu A$ ( $\overline{RESET}$ unasserted)	$0.8 \times$ $V_{IN2}$			V
Output High Source Current	$I_{OH}$	$V_{IN2} > 2.55V$ ( $\overline{RESET}$ unasserted)	6	10		$\mu A$

**Note 1:** 100% production tested at  $T_A = +25^\circ C$ . Limits over temperature guaranteed by design.

**Note 2:** The device is powered from input IN2.

**Note 3:** The  $\overline{RESET}$  output is guaranteed to be in the correct state for IN1 or IN2 down to 1V.

**Note 4:** Monitored voltage ( $+3.3V$ ,  $+3.0V$ ) is also the device power supply. Supply current splits as follows:  $25\mu A$  for the resistor-divider (for the monitored voltage) and  $30\mu A$  for other circuits.

## Typical Operating Characteristics

( $V_{IN2} = +3.0V$ ,  $T_A = +25^\circ C$ )

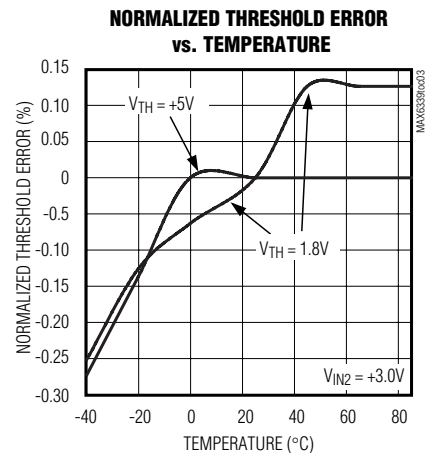
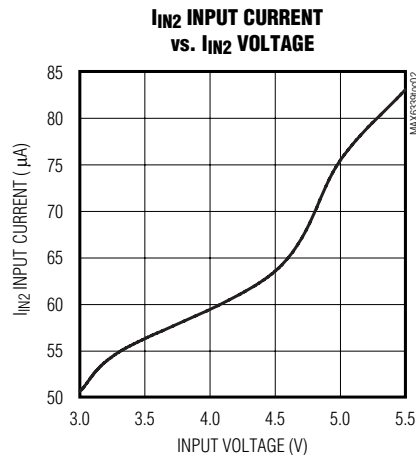
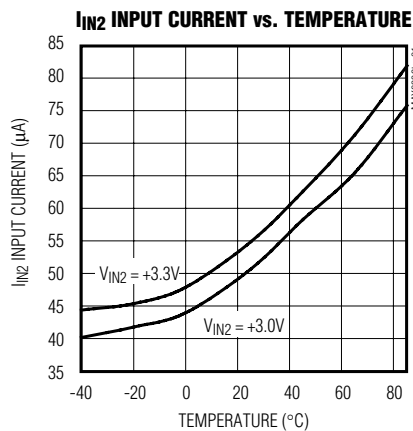

# Quad Voltage $\mu$ P Supervisory Circuit in SOT Package

## Typical Operating Characteristics (continued)

( $V_{IN2} = +3.0V$ ,  $T_A = +25^\circ C$ )

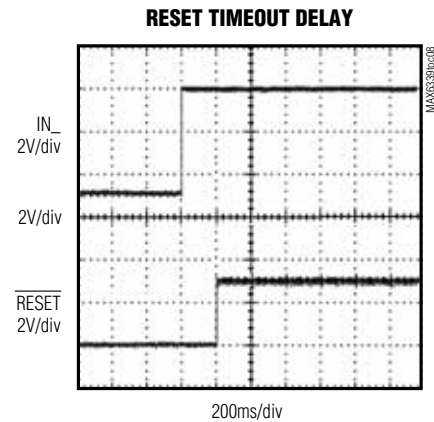
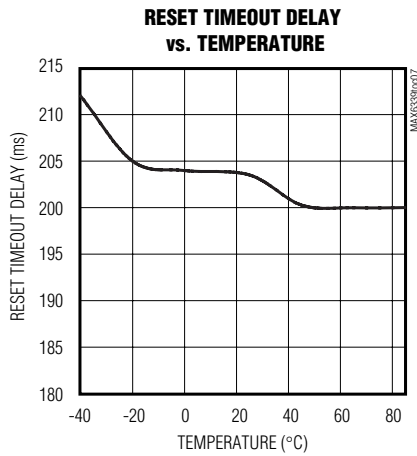
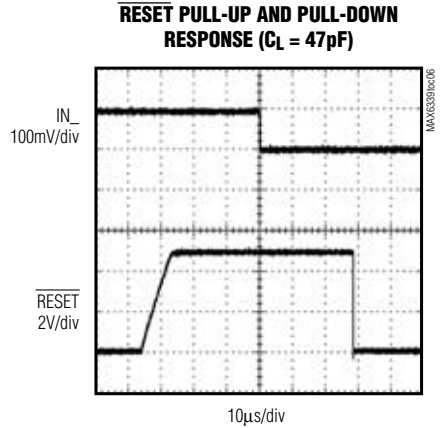
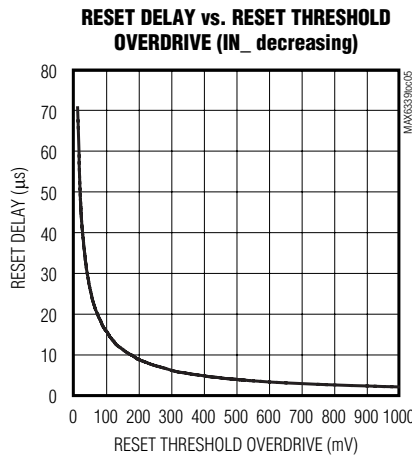
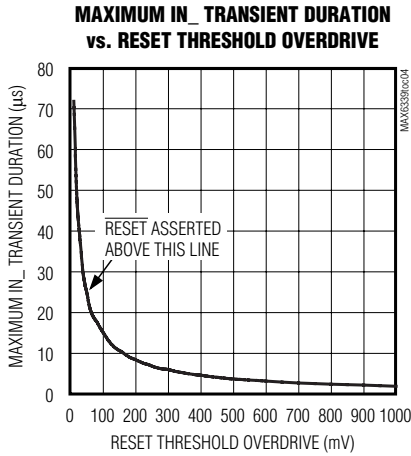

## Pin Description

PIN	NAME	FUNCTION
1	IN1	Input Voltage 1. See <i>Selector Guide</i> for monitored voltages.
2	IN2	Input Voltage 2. See <i>Selector Guide</i> for monitored voltages. IN2 is the power-supply input for the device.
3	IN3	Input Voltage 3. See <i>Selector Guide</i> for monitored voltages.
4	IN4	Input Voltage 4. See <i>Selector Guide</i> for monitored voltages.
5	GND	Ground
6	$\overline{\text{RESET}}$	Reset Output, Active Low. $\overline{\text{RESET}}$ goes low when any input goes below its specified threshold. After all inputs are above their threshold voltage, $\overline{\text{RESET}}$ remains low for at least 140ms (minimum) before going high. $\overline{\text{RESET}}$ output is open drain with a weak internal pullup to IN2.

# Quad Voltage $\mu$ P Supervisory Circuit in SOT Package

## Detailed Description

The MAX6339 is a very small, low-power, quad voltage  $\mu$ P supervisory circuit designed to maintain system integrity in multi-supply systems (Figure 1). The device offers several internally trimmed undervoltage threshold options that minimize or eliminate the need for external components. Preset voltage monitoring options for +5.0V, +3.3V, +3.0V, +2.5V, +1.8V, and -5.0V make it ideal for telecommunications, desktop and notebook computers, high-end printers, data storage equipment, and networking equipment applications.

The quad monitor/reset includes an accurate bandgap reference, four precision comparators, and a series of internal trimmed resistor-divider networks to set the factory-fixed reset threshold options. The resistor networks scale the specified IN\_ reset voltages to match the internal bandgap reference/comparator voltage. User-adjustable threshold options bypass the internal resistor networks and connect directly to one of the comparator inputs (an external resistor-divider network is required for threshold matching). All threshold voltage options, fixed and adjustable, are indicated through a single-letter code in the product number (see *Selector Guide*).

Each of the internal comparators has a typical hysteresis of 0.3% with respect to its reset threshold. This built-in hysteresis improves the monitor's immunity to ambient noise without significantly reducing threshold accuracy when an input sits at its specified reset voltage. The MAX6339 is also designed to ignore short IN\_ transients. See *Typical Operating Characteristics* for a glitch immunity graph.

## Applications Information

### Reset Output

The MAX6339  $\overline{\text{RESET}}$  output is asserted low when any of the monitored IN\_ voltages drop below its specified reset threshold (or above for -5V option) and remain low for the reset timeout period (140ms minimum) after all inputs exceed their thresholds (Figure 2). The output is open drain with a weak internal pullup to the monitored IN2 supply (10 $\mu$ A typ). For many applications no external pullup resistor is required to interface with other logic devices. An external pullup resistor to any voltage from 0 to +5.5V can overdrive the internal pullup if interfacing to different logic supply voltages (Figure 3). Internal circuitry prevents reverse current flow from the external pullup voltage to IN2.

The MAX6339 is normally powered from the monitored IN2 supply when all input voltages are above their specified thresholds. When any supply drops below its

threshold, the reset output is asserted and guaranteed to remain low while either IN1 or IN2 is above +1.0V.

### User-Adjustable Thresholds

The MAX6339 offers several monitor options with user-adjustable reset thresholds. The threshold voltage at each adjustable IN\_ input is typically 1.23V. To monitor a voltage >1.23V, connect a resistor-divider network to the circuit as shown in Figure 4.

$$V_{\text{INTH}} = 1.23\text{V} \times (R1 + R2) / R2$$

or, solved in terms of R1:

$$R1 = R2 \left( (V_{\text{INTH}} / 1.23\text{V}) - 1 \right)$$

Because the MAX6339 has a guaranteed input current of  $\pm 0.1\mu\text{A}$  on its adjustable inputs, resistor values up to 100k $\Omega$  can be used for R2 with <1% error.

### Unused Inputs

If some monitor inputs are to be unused, they must be tied to a supply voltage greater in magnitude than their specified threshold voltages. For unused IN3 or IN4 options with positive thresholds (fixed or adjustable), the inputs can be connected directly to the IN2 supply. For unused IN4 options with negative thresholds, the input must be tied to a more negative supply. The IN2 input must always be used for normal operation (device power-supply pin). Unused pins cannot be connected to ground or allowed to float.

### Negative Voltage Monitoring Beyond -5V

The MAX6339 is offered with options to monitor -5V supplies with internally fixed thresholds. To monitor supplies more negative than -5V, a low-impedance resistor-divider network can be used external to the MAX6339 as shown in Figure 5. The current through the external resistor-divider should be greater than the input current for the -5V monitor options. For an input monitor current error of <1%, the resistor-divider current should  $\geq 2\text{mA}$  (for  $I_{\text{IN4}} = 20\mu\text{A}$  max). Set  $R2 = 2.5\text{k}\Omega$ . Calculate R1 based on the desired  $V_{\text{IN}_}$  reset threshold voltage, using the following formula:

$$R1 = R2 \times [(V_{\text{INTH}} / V_{\text{TH}}) - 1]$$

where  $R2 \leq 2.49\text{k}\Omega$ ,  $V_{\text{INTH}}$  = desired threshold voltage and  $V_{\text{TH}}$  is the internal threshold voltage.

# Quad Voltage $\mu$ P Supervisory Circuit in SOT Package

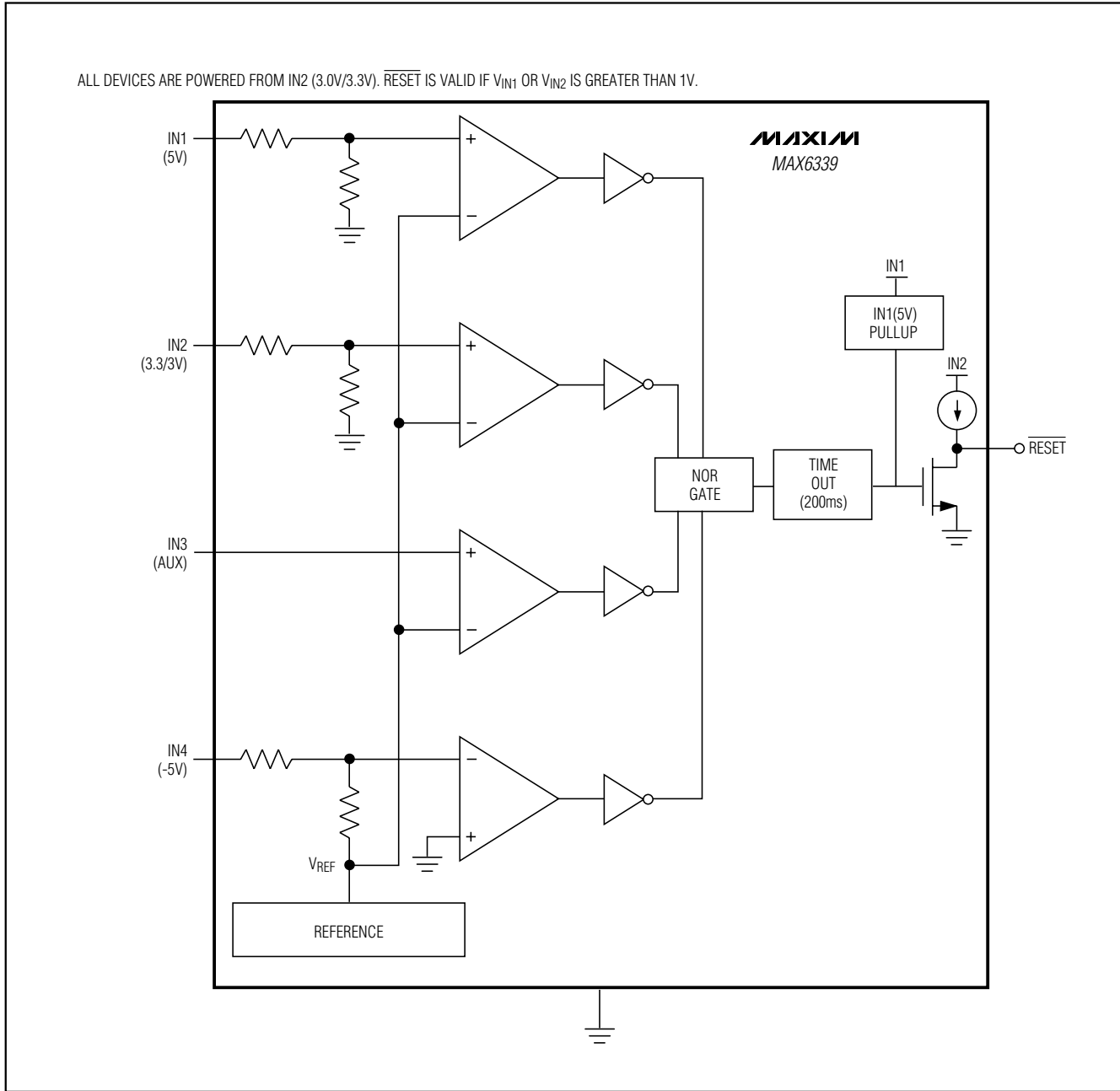

Figure 1. MAX6339 Functional Diagram

# Quad Voltage $\mu$ P Supervisory Circuit in SOT Package

MAX6339

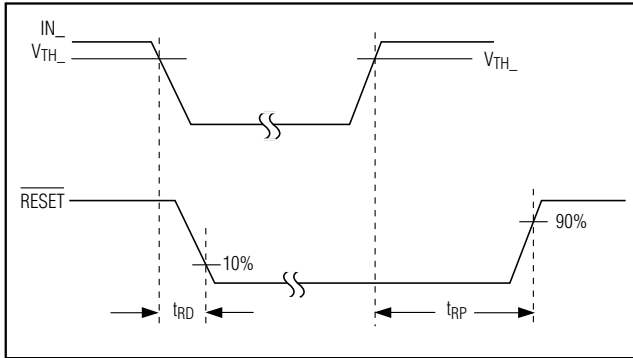

Figure 2.  $\overline{\text{RESET}}$  Output Timing Diagram

For  $-V_{IN} = -12\text{V}$  nominal,  $V_{INTH} = -11.1\text{V}$ ,  $V_{TH} = -4.63\text{V}$ , and  $R_2 = 2.49\text{k}\Omega$ ,

$$R_1 = 2.49\text{k}\Omega \times [(-11.1 / -4.63) - 1]$$

$$R_1 = 3.48\text{k}\Omega$$

### Power-Supply Bypassing and Grounding

The MAX6339 is normally powered from the monitored IN2 supply input. All monitor inputs are immune to short supply transients. If higher immunity is desired in noisy applications, connect  $0.1\mu\text{F}$  bypass capacitors from the IN2 input to ground. Additionally, capacitance can be added to IN1, IN3, and IN4 to increase their noise immunity.

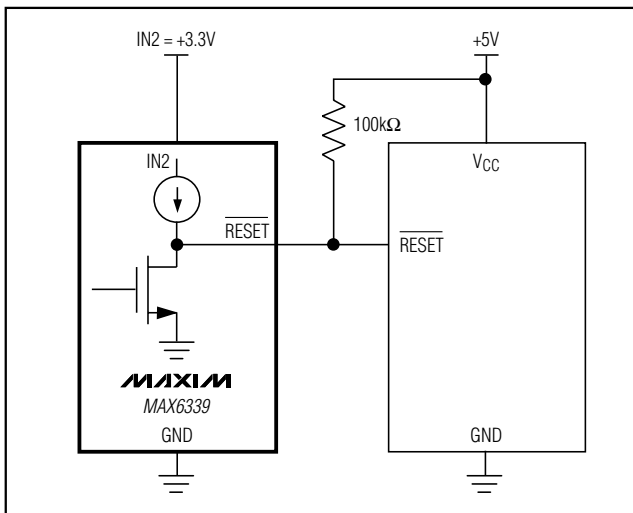

Figure 3. Interfacing to Different Logic Supply Voltage

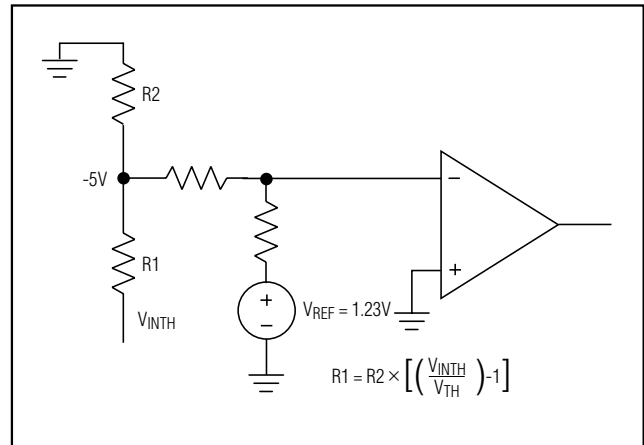

Figure 5. Negative Voltage Monitoring Beyond  $-5\text{V}$

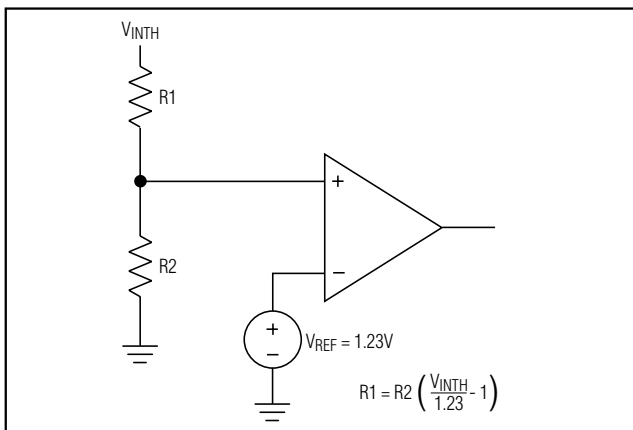
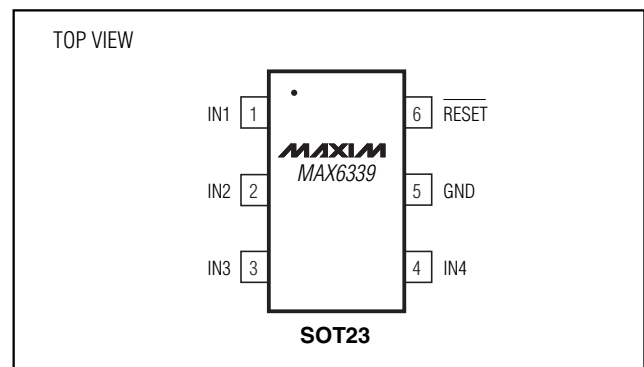

Figure 4. Setting the Auxiliary Monitor

### Pin Configuration



### Chip Information

TRANSISTOR COUNT: 896

PROCESS: BiCMOS

# Quad Voltage $\mu$ P Supervisory Circuit in SOT Package

**MAX6339**

## Selector Guide

PART	NOMINAL INPUT VOLTAGE				SUPPLY TOLERANCE (%)	TOP MARK
	IN1 (V)	IN2 (V)	IN3 (V)	IN4 (V)		
MAX6339AUT	5	3.3	2.5	Adj*	10	AAJU
MAX6339BUT	5	3.3	2.5†	Adj*	5	AAJV
MAX6339CUT	5	3.3	1.8	Adj*	10	AAJW
MAX6339DUT	5	3.3	1.8†	Adj*	5	AAJX
MAX6339EUT	5	3.0	2.5	Adj*	10	AAJY
MAX6339FUT	5	3.0	2.5†	Adj*	5	AAJZ
MAX6339GUT	5	3.0	1.8	Adj*	10	AAKA
MAX6339HUT	5	3.0	1.8†	Adj*	5	AAKB
MAX6339IUT	5	3.3	2.5	1.8	10	AAKC
MAX6339JUT	5	3.3	2.5†	1.8†	5	AAKD
MAX6339KUT	Adj*	3.3	2.5	Adj*	10	AAKE
MAX6339LUT	Adj*	3.3	2.5	Adj*	5	AAKF
MAX6339MUT	5	3.0	Adj*	-5	10	AAKG
MAX6339NUT	5	3.0	Adj*	-5	5	AAKH
MAX6339OUT	5	3.3	Adj*	-5	10	AAKI
MAX6339PUT	5	3.3	Adj*	-5	5	AAKJ

\*Adjustable voltage based on +1.23V internal threshold. External threshold voltage can be set using an external resistor-divider.

†Normal input voltages for 1.8V and 2.5V are specified for 10% tolerances.



# Quad Voltage $\mu$ P Supervisory Circuit in SOT Package

## Package Information

**MAX6339**

SEE NOTE 5  
EXAMPLE  
TOP MARK

PIN 1  
I.D. DOT  
(SEE NOTE 6)

PIN #1

0.20  
DATUM 'A'

6LSOTEPS

SYMBOL	MIN	MAX
A	0.90	1.45
A1	0.00	0.15
A2	0.90	1.30
b	0.35	0.50
C	0.08	0.20
D	2.80	3.00
E	2.60	3.00
E1	1.50	1.75
L	0.35	0.55
e	0.95 REF	
$\alpha$	0°	10°

NOTES:

1. ALL DIMENSIONS ARE IN MILLIMETERS.
2. FOOT LENGTH MEASURED AT INTERCEPT POINT BETWEEN DATUM A & LEAD SURFACE.
3. PACKAGE OUTLINE EXCLUSIVE OF MOLD FLASH & METAL BURR.
4. PACKAGE OUTLINE INCLUSIVE OF SOLDER PLATING.
5. PIN 1 IS LOWER LEFT PIN WHEN READING TOP MARK FROM LEFT TO RIGHT. (SEE EXAMPLE TOP MARK)
6. PIN 1 I.D. DOT IS 0.3 MM  $\phi$  MIN. LOCATED ABOVE PIN 1.
7. MEETS JEDEC MO178.

PROPRIETARY INFORMATION

TITLE:  
PACKAGE OUTLINE, SOT-23, 6L

APPROVAL	DOCUMENT CONTROL NO. 21-0058	REV E	1/1
----------	---------------------------------	----------	-----

Maxim cannot assume responsibility for use of any circuitry other than circuitry entirely embodied in a Maxim product. No circuit patent licenses are implied. Maxim reserves the right to change the circuitry and specifications without notice at any time.

Maxim Integrated Products, 120 San Gabriel Drive, Sunnyvale, CA 94086 408-737-7600 9