

0.5Ω, Quad SPDT Switches in UCSP/QFN

General Description

The MAX4754/MAX4755/MAX4756 low on-resistance, analog switches operate from a single +1.8V to +5.5V supply. The MAX4754 and MAX4755 are dual, double-pole, double-throw (DPDT) switches. The MAX4756 is a quad, single-pole double-throw (SPDT) switch. They are configured to route either audio or data signals.

The MAX4754 has four 0.5Ω SPDT switches for audio-signal routing and two logic control inputs. The MAX4755 has four 0.5Ω SPDT switches (with two switches that have an additional 11Ω series resistor at the NC terminals). This allows users to drive an 8Ω speaker as a 32Ω load (ear speaker). The MAX4756 has four 0.5Ω SPDT switches controlled by one logic control input and an enable pin (EN) to disable the switches.

The MAX4754/MAX4755/MAX4756 are available in a space-saving 16-pin thin QFN and a tiny 16-bump 2mm x 2mm chip-scale package (UCSP™).

Applications

Speaker-Headset Switching
Audio-Signal Routing
Cellular Phones
PDAs/Hand-Held Devices
Notebook Computers

UCSP is a trademark of Maxim Integrated Products, Inc.

Features

- ◆ Data and Audio-Signal Routing
- ◆ Low R_{ON} (0.5Ω) Audio Switches
- ◆ 0.1Ω Channel-to-Channel Matching
- ◆ 0.2Ω On-Resistance Flatness
- ◆ 0.02% THD
- ◆ +1.8V to +5.5V Supply Range
- ◆ Rail-to-Rail Signal Handling
- ◆ 16-Bump UCSP (2mm x 2mm)

Ordering Information

PART	TEMP RANGE	PIN-PACKAGE
MAX4754 EBE-T	-40°C to +85°C	16 UCSP-16
MAX4754ETE	-40°C to +85°C	16 Thin QFN (4mm x 4mm)
MAX4755 EBE-T*	-40°C to +85°C	16 UCSP-16
MAX4755ETE*	-40°C to +85°C	16 Thin QFN (4mm x 4mm)
MAX4756 EBE-T*	-40°C to +85°C	16 UCSP-16
MAX4756ETE*	-40°C to +85°C	16 Thin QFN (4mm x 4mm)

* Future product—contact factory for availability.

Pin Configurations appear at end of data sheet.

Functional Diagrams

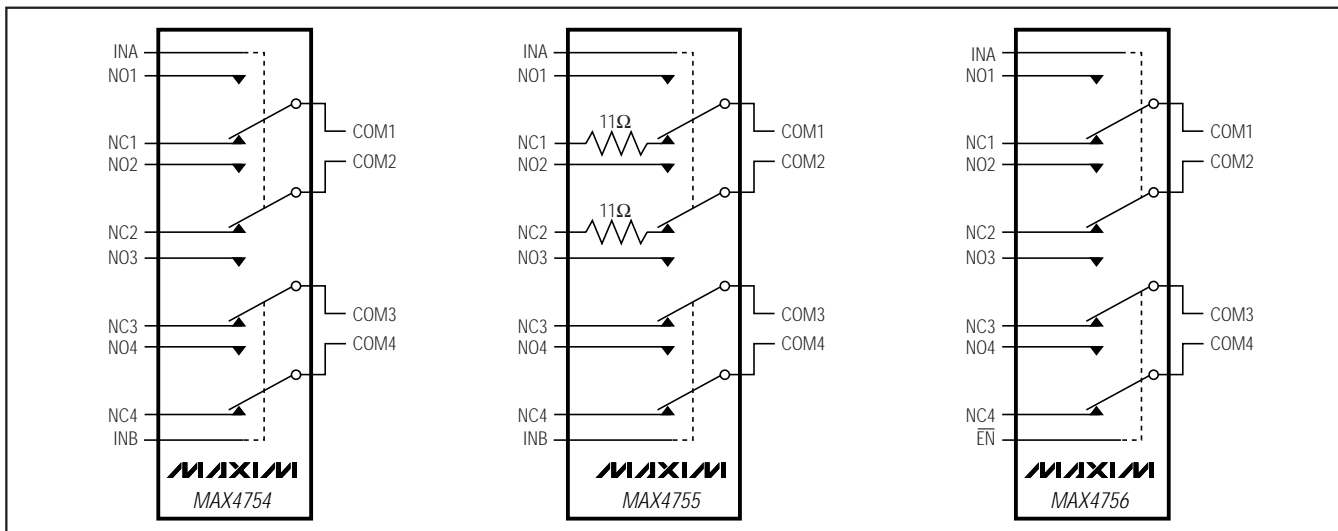

0.5Ω, Quad SPDT Switches in UCSP/QFN

ABSOLUTE MAXIMUM RATINGS

(All Voltages Referenced to GND)

V+, IN_, EN_	-0.3V to +6V
COM_, NO_, NC_ (Note 1)	-0.3V to (V+ + 0.3V)
Continuous Current	
NC1, NC2, COM1, COM2 (MAX4755)	±100mA
NO_, NC_, COM_ (remaining terminal connections)	±300mA
Peak Current NC1, NC2, COM1, COM2 (MAX4755)	
(Pulsed at 1ms, 10% duty cycle)	±200mA
(Pulsed at 1ms, 50% duty cycle)	±150mA
Peak Current NO_, NC_, COM_ (remaining terminal connections)	
(Pulsed at 1ms, 10% duty cycle)	±500mA
(Pulsed at 1ms, 50% duty cycle)	±400mA

Continuous Power Dissipation (T_A = +70°C)

16-Bump UCSP (derate 8.2mW/°C above +70°C)	660mW
16-Pin Thin QFN (derate 16.9mW/°C above +70°C)	1349mW
ESD per Method 3015.7	±2kV
Operating Temperature Range	-40°C to +85°C
Junction Temperature	+150°C
Storage Temperature Range	-65°C to +150°C
Bump Temperature (soldering)	
Infrared (15s)	+220°C
Vapor Phase (60s)	+215°C
Lead Temperature (soldering, 10s)	+300°C

Note 1: Signals on NO_, NC_, COM_ exceeding V+ or GND are clamped by internal diodes. Limit forward-diode current to maximum current rating.

Stresses beyond those listed under "Absolute Maximum Ratings" may cause permanent damage to the device. These are stress ratings only, and functional operation of the device at these or any other conditions beyond those indicated in the operational sections of the specifications is not implied. Exposure to absolute maximum rating conditions for extended periods may affect device reliability.

ELECTRICAL CHARACTERISTICS

(V+ = +2.7V to +5.25V, T_A = -40°C to +85°C, unless otherwise noted. Typical values are at +3V and T_A = +25°C.) (Notes 2, 3)

PARAMETER	SYMBOL	CONDITIONS		T _A	MIN	TYP	MAX	UNITS
ANALOG SWITCH								
Analog Signal Range	V _{COM_} , V _{NO_} , V _{NC_}			T _{MIN} to T _{MAX}	0		V+	V
On-Resistance	R _{ON}	V+ = 2.7V, I _{COM_} = 10mA, V _{NC_} = 0V, or V _{NC_} = V+ (Note 4)	MAX4755 (NO1, NO2, N_3, N_4), MAX4754/MAX4756	+25°C		0.5	0.85	Ω
				T _{MIN} to T _{MAX}			1.0	
			MAX4755 (NC1, NC2)	+25°C		11.5		
				T _{MIN} to T _{MAX}	8.0		12.5	
On-Resistance Match Between Channels	ΔR _{ON}	V+ = 2.7V, I _{COM_} = 10mA, V _{NO_} = 1.5V, or V _{NC_} = 1.5V (Notes 4, 5)	MAX4755 (NO1, NO2, N_3, N_4), MAX4754/MAX4756	+25°C		0.1	0.35	Ω
				T _{MIN} to T _{MAX}			0.55	
			MAX4755 (NC1, NC2)	+25°C		0.2	0.4	
				T _{MIN} to T _{MAX}			0.55	
On-Resistance Flatness	R _{FLAT(ON)}	V+ = 3V, I _{COM_} = 10mA, V _{NO_} = 0V, or V _{NC_} = V+ (Note 6)	MAX4755 (NO1, NO2, N_3, N_4, NO1, NO2), MAX4754/MAX4756	+25°C		0.2	0.4	Ω
				T _{MIN} to T _{MAX}			0.55	
NO_, NC_ Off-Leakage Current	I _{NO_(OFF)} , I _{NC_(OFF)}	V+ = 3.6V; V _{COM_} = 3.3V, 0.3V; V _{NO_} or V _{NC_} = 0.3V, 3.3V		+25°C	-3		+3	nA
				T _{MIN} to T _{MAX}	-10		+10	
COM_ Off-Leakage Current	I _{COM_(OFF)}	V+ = 3.6V (MAX4756); V _{COM_} = 3.3V, 0.3V; V _{NO_} or V _{NC_} = 0.3V, 3.3V		+25°C	-3	±0.01	+3	nA
				T _{MIN} to T _{MAX}	-10		+10	

0.5Ω, Quad SPDT Switches in UCSP/QFN

MAX4754/MAX4755/MAX4756

ELECTRICAL CHARACTERISTICS (Continued)

(V+ = +2.7V to +5.25V, TA = -40°C to +85°C, unless otherwise noted. Typical values are at +3V and TA = +25°C.) (Notes 2, 3)

PARAMETER	SYMBOL	CONDITIONS	TA	MIN	TYP	MAX	UNITS
COM_ On-Leakage Current	ICOM_(ON)	V+ = 3.6V; VCOM_ = 3.3V, 0.3V; VNO_ or VNC_ = 3.3V, 0.3V or floating	+25°C	-3		+3	nA
			TMIN to TMAX	-10		+10	
DYNAMIC							
Turn-On Time	tON	V+ = 2.7V, VNO_ or VNC_ = 1.5V; RL = 50Ω; CL = 35pF, Figure 1	+25°C		45	140	ns
			TMIN to TMAX			150	
Turn-Off Time	tOFF	V+ = 2.7V, VNO_ or VNC_ = 1.5V; RL = 50Ω; CL = 35pF, Figure 1	+25°C		25	50	ns
			TMIN to TMAX			60	
Break-Before-Make	tBBM	V+ = 2.7V, VNO_ or VNC_ = 1.5V; RL = 50Ω, CL = 35pF, Figure 2 (Note 7)	+25°C		15		ns
			TMIN to TMAX		2		
Charge Injection	Q	VGEN = 0V, RGEN = 0, CL = 1.0nF, Figure 3	+25°C		50		pC
On-Channel -3dB Bandwidth	BW	Signal = 0dBm, CL = 50pF, RL = 50Ω,	+25°C		325		MHz
Off-Isolation	VISO	CL = 5pF, RL = 50Ω, VCOM_ = 1VP-P f = 100kHz, Figure 4 (Note 8)	+25°C		-120		dB
Crosstalk	VCT	CL = 5pF, RL = 50Ω, VCOM_ = 1VP-P f = 100kHz, Figure 4 (Note 9)	+25°C		-120		dB
Total Harmonic Distortion	THD	f = 20Hz to 20kHz, 1VP-P, RL = 32Ω	+25°C		0.02		%
NO_, NC_ Off-Capacitance	CNO_(OFF), CNC_(OFF)	VNO, VNC_ = GND, f = 1MHz, VCOM_ = 0.5VP-P, Figure 5	+25°C		65		pF
COM_ Off-Capacitance	C _{COM_(OFF)}	VCOM_ = GND, f = 1MHz, MAX4756, Figure 5	+25°C		110		pF
COM_ On-Capacitance	C(ON)	VCOM_ = VNO, VNC_ = GND, f = 1MHz, VCOM_ = 0.5VP-P, Figure 5	+25°C		168		pF
DIGITAL I/O (IN_, EN)							
Input Logic High	VIH	V+ = 2.7V to 3.6V	TMIN to TMAX	1.4			V
		V+ = 3.6V to 5.25V	TMIN to TMAX	2.0			
Input Logic Low	VIL	V+ = 2.7V to 3.6V	TMIN to TMAX			0.5	V
		V+ = 3.6V to 5.25V	TMIN to TMAX			0.6	
Input Leakage Current	IIN	VIN = 0V or V+	TMIN to TMAX			1	μA

0.5Ω, Quad SPDT Switches in UCSP/QFN

ELECTRICAL CHARACTERISTICS (Continued)

(V+ = +2.7V to +5.25V, T_A = -40°C to +85°C, unless otherwise noted. Typical values are at +3V and T_A = +25°C.) (Notes 2, 3)

PARAMETER	SYMBOL	CONDITIONS	T _A	MIN	TYP	MAX	UNITS
POWER SUPPLY							
Power-Supply Range	V+		T _{MIN} to T _{MAX}	1.8		5.5	V
Positive-Supply Current	I+	V+ = 5.5V, V _{IN_} = 0V or V+	+25°C	0.001			μA
			T _{MIN} to T _{MAX}		1.0		

Note 2: The algebraic convention is used in this data sheet; the most negative value is shown in the minimum column.

Note 3: UCSP parts are 100% tested at +25°C and limits across the full temperature range are guaranteed by correlation and design. Thin QFN parts are 100% tested at +85°C and limits across the full temperature range are guaranteed by correlation and design.

Note 4: R_{ON} and ΔR_{ON} matching specifications are guaranteed by design.

Note 5: ΔR_{ON} = R_{ON(MAX)} - R_{ON(MIN)}.

Note 6: Flatness is defined as the difference between the maximum and minimum value of on-resistance as measured over the specified analog signal ranges.

Note 7: Guaranteed by design, not production tested.

Note 8: Off-Isolation = 20log₁₀ [V_{COM} / (V_{NO} or V_{NC})], V_{COM} = output, V_{NO} or V_{NC} = input to off switch.

Note 9: Between any two switches.

0.5Ω, Quad SPDT Switches in UCSP/QFN

Typical Operating Characteristics

(V+ = 3V, TA = +25°C, unless otherwise noted.)

MAX4754/MAX4755/MAX4756

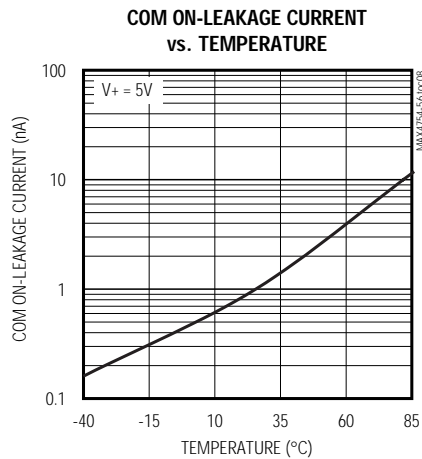
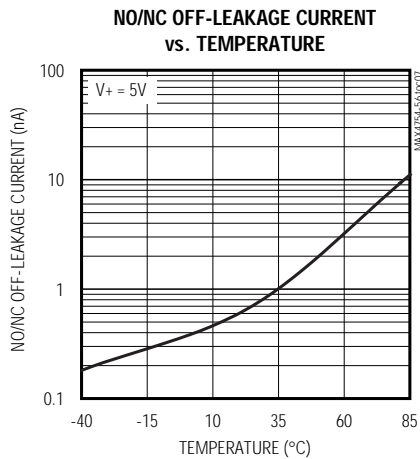
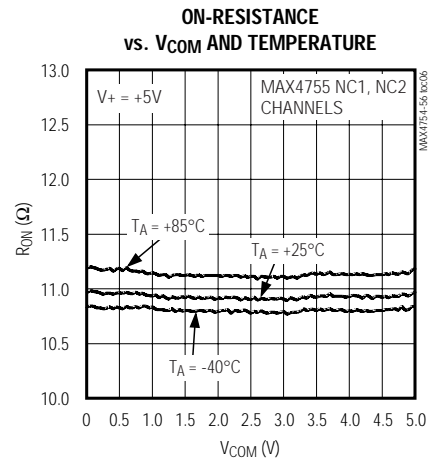
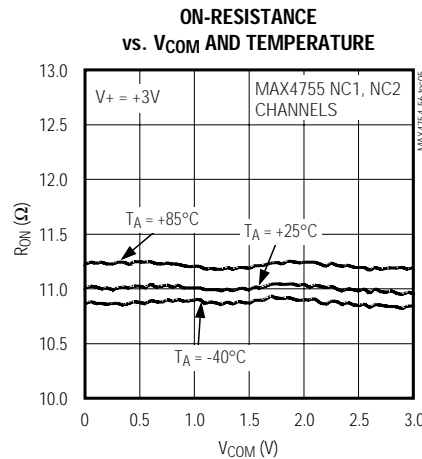
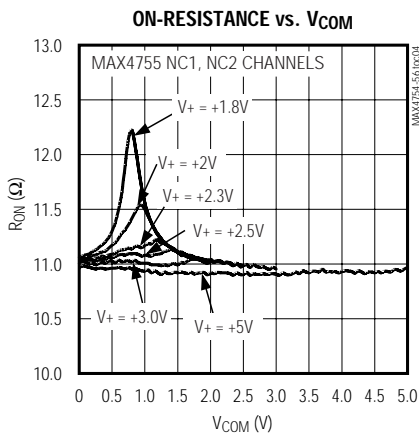
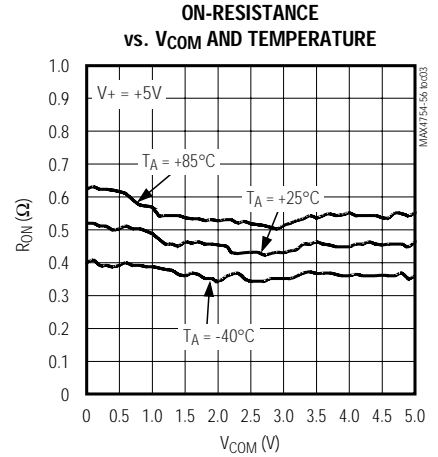
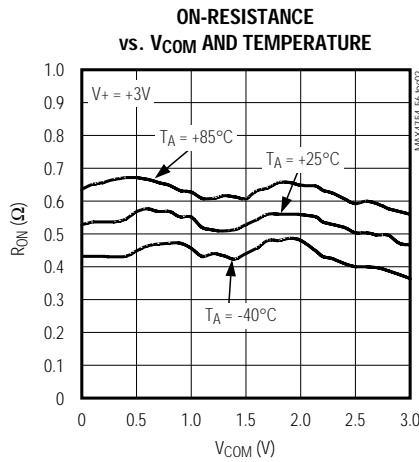
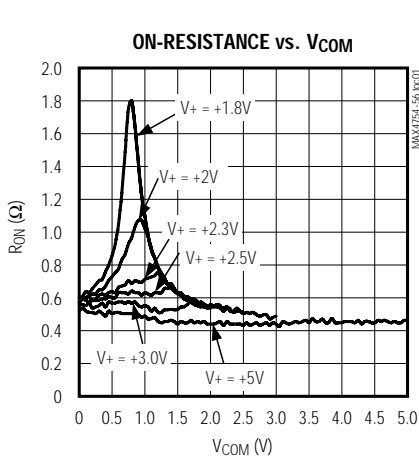

0.5Ω, Quad SPDT Switches in UCSP/QFN

Typical Operating Characteristics (continued)

(V+ = 3V, TA = +25°C, unless otherwise noted.)

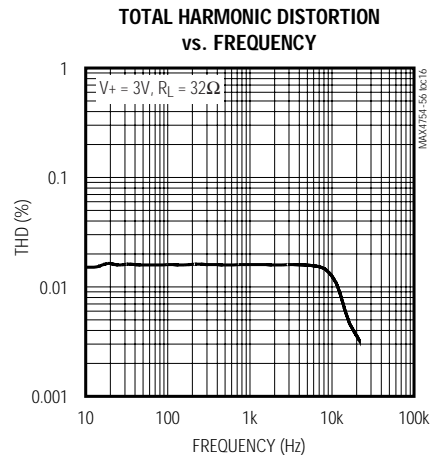
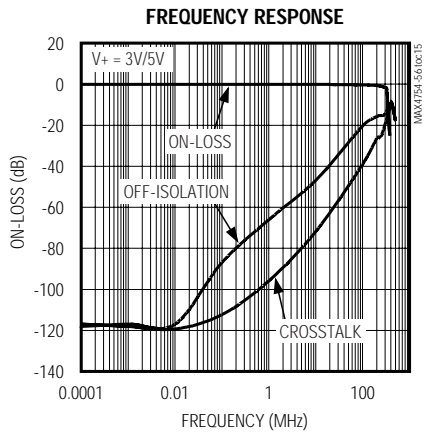
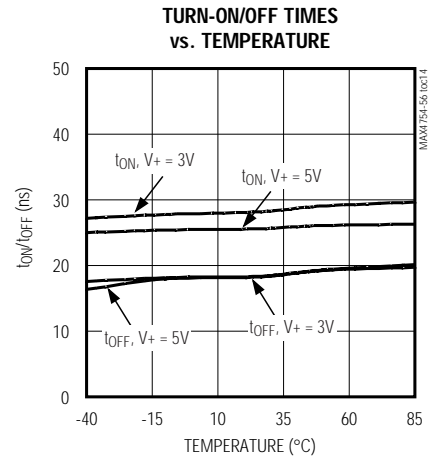
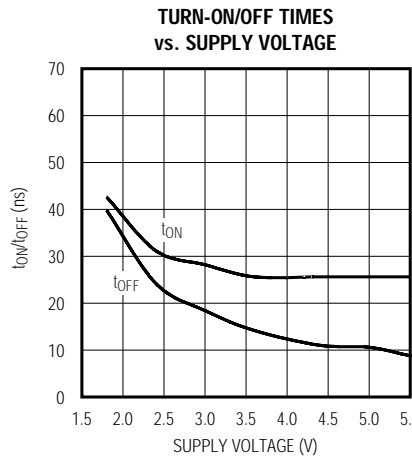
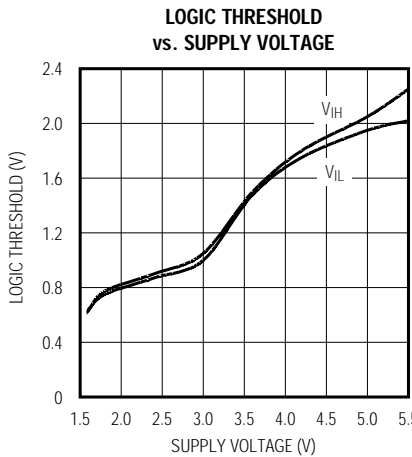
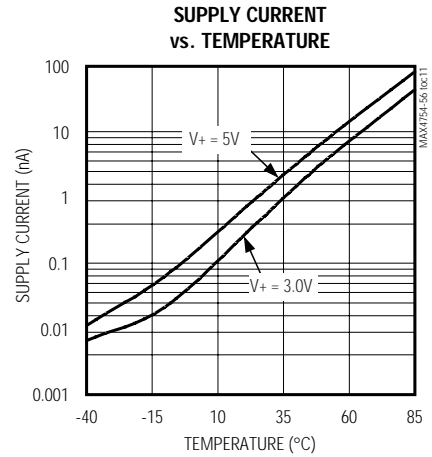
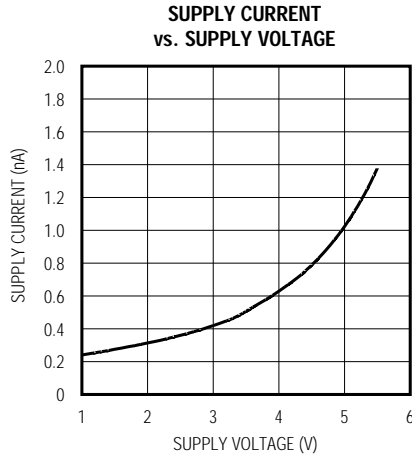
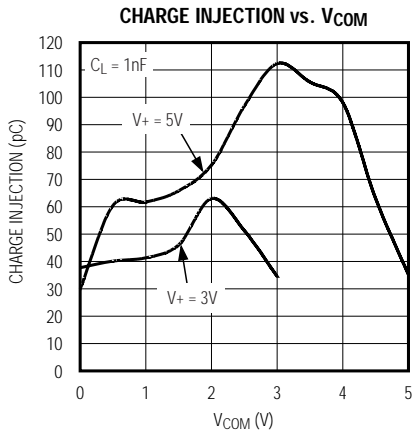

0.5Ω, Quad SPDT Switches in UCSP/QFN

Pin Description

PIN						NAME	FUNCTION
MAX4754		MAX4755		MAX4756			
UCSP	QFN	UCSP	QFN	UCSP	QFN		
C1	1	C1	1	C1	1	NO1	Analog Switch 1. Normally open terminal 1.
C2	2	C2	2	C2	2	INA	Logic Control Digital Input for Switches 1 and 2. Digital control input for switches 1–4 for MAX4756.
B1	3	B1	3	B1	3	COM1	Analog Switch 1. Common terminal.
A1	4	A1	4	A1	4	NC1	Analog Switch 1. Normally closed terminal 1.
A2	5	A2	5	A2	5	NO4	Analog Switch 4. Normally open terminal 4.
B2	6	B2	6	B2	6	V+	Positive Supply Voltage
A3	7	A3	7	A3	7	COM4	Analog Switch 4. Common terminal.
A4	8	A4	8	A4	8	NC4	Analog Switch 4. Normally closed terminal 4.
B4	9	B4	9	B4	9	NO2	Analog Switch 2. Normally open terminal 2.
B3	10	B3	10	—	—	INB	Logic Control Digital Input for Switches 3 and 4
—	—	—	—	B3	10	EN	Output Enable. Active low.
C4	11	C4	11	C4	11	COM2	Analog Switch 2. Common terminal 2.
D4	12	D4	12	D4	12	NC2	Analog Switch 2. Normally closed terminal 2.
D3	13	D3	13	D3	13	NO3	Analog Switch 3. Normally open terminal 3.
C3	14	C3	14	C3	14	GND	Ground
D2	15	D2	15	D2	15	COM3	Analog Switch 3. Common terminal 3.
D1	16	D1	16	D1	16	NC3	Analog Switch 4. Normally closed terminal 3.
—	PAD	—	PAD	—	PAD	EP	Exposed Pad. Connect to GND.

MAX4754/MAX4755/MAX4756

Typical Operating Circuit

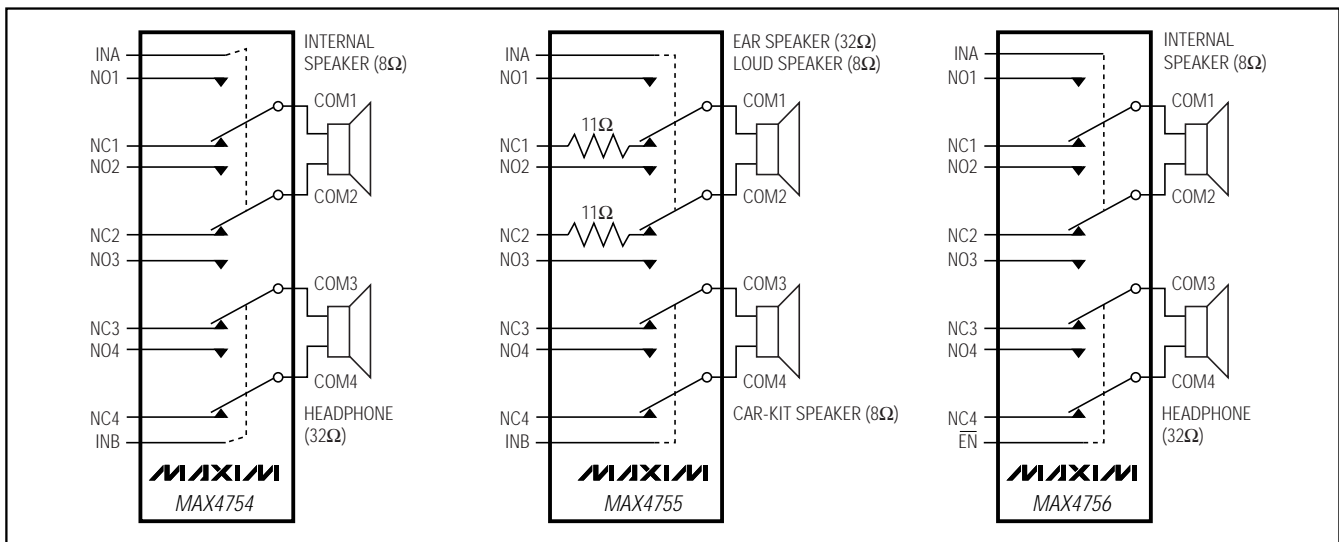

0.5Ω, Quad SPDT Switches in UCSP/QFN

Detailed Description

The MAX4754/MAX4755/MAX4756 low on-resistance analog switches operate from a single +1.8V to +5.5V supply. The devices are fully specified for nominal 3V applications.

The MAX4754 DPDT switch has two logic control inputs with each input controlling two SPDT switches. Each switch has a 0.5Ω on-resistance in the NO and NC terminals making it ideal for switching audio signals.

The MAX4755 DPDT switch also has four 0.5Ω SPDT switches with the switch pairs 1 and 2 adding an 11.5Ω series resistor to the NC terminal. This feature allows the user to drive an 8Ω speaker as a 32Ω load, allowing it to be used as an ear speaker. Two logic control inputs are used to control the four switches.

The MAX4756 has four 0.5Ω SPDT switches controlled by one logic control input (INA) and $\overline{\text{EN}}$ input to disable the switches.

Applications Information

Digital Control Inputs

The MAX4754/MAX4755/MAX4756 logic inputs accept up to +5.5V regardless of the supply voltage. For example, with a +3.3V supply IN₋ can be driven low to GND and high to +5.5V, which allows mixed logic levels in a system. Driving the control logic inputs rail-to-rail also minimizes power consumption. For a +3V supply voltage, the logic thresholds are 0.5V (low) and 1.4V (high).

For the MAX4756, drive $\overline{\text{EN}}$ low to enable the COM₋. When $\overline{\text{EN}}$ is high, COM₋ is high impedance.

Analog Signal Levels

Analog signal inputs over the full voltage range (0V to V₊) are passed through the switch with minimal change in on-resistance (see the *Typical Operating Characteristics*). The switches are bidirectional so NO₋, NC₋, and COM₋ can be either inputs or outputs.

Power-Supply Bypassing

Power-supply bypassing improves noise margin and prevents switching noise from propagating from the V₊ supply to other components. A 0.1μF capacitor connected from V₊ to GND is adequate for most applications.

UCSP Applications Information

For the latest application details on UCSP construction, dimensions, tape carrier information, printed circuit board techniques, bump-pad layout, and recommended reflow temperature profile, as well as the latest information on reliability testing results, go to the Maxim website at www.maxim-ic.com/ucsp for the Application Note: *UCSP—A Wafer-Level Chip-Scale Package*.

0.5Ω, Quad SPDT Switches in UCSP/QFN

Timing Circuits/Timing Diagrams

MAX4754/MAX4755/MAX4756

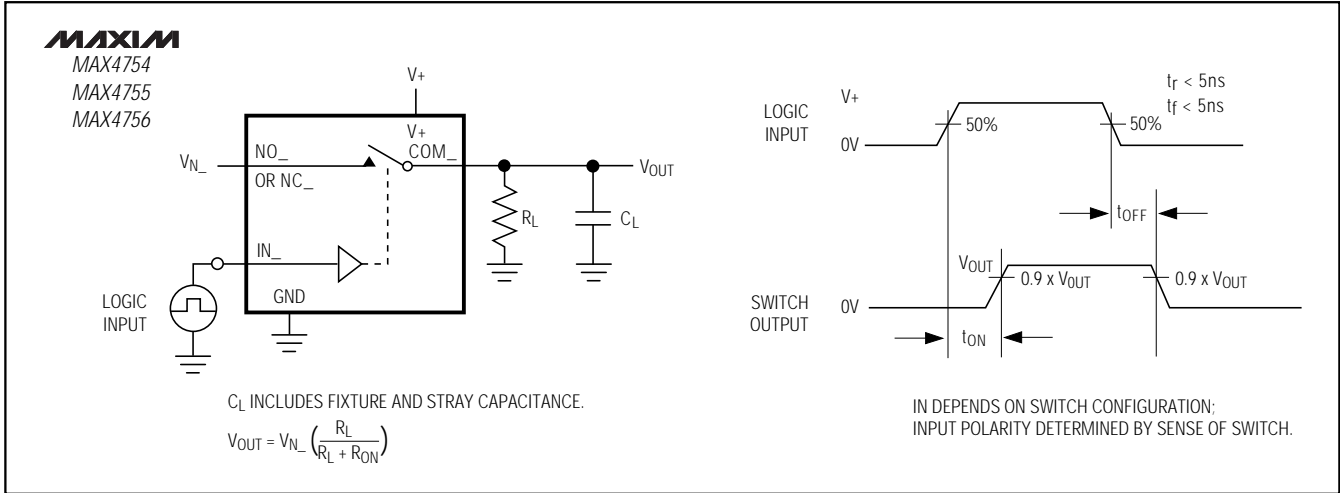

Figure 1. Switching Time

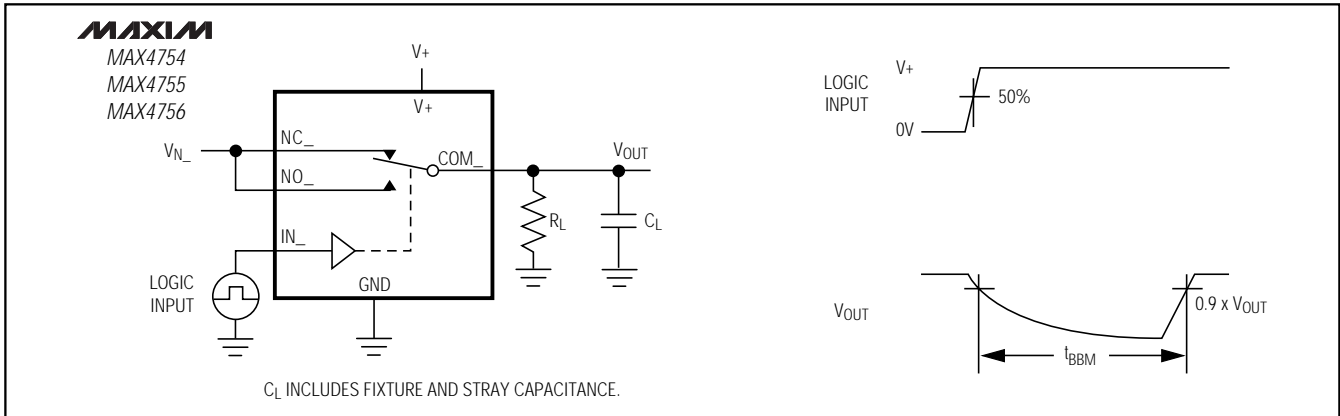

Figure 2. Break-Before-Make Interval

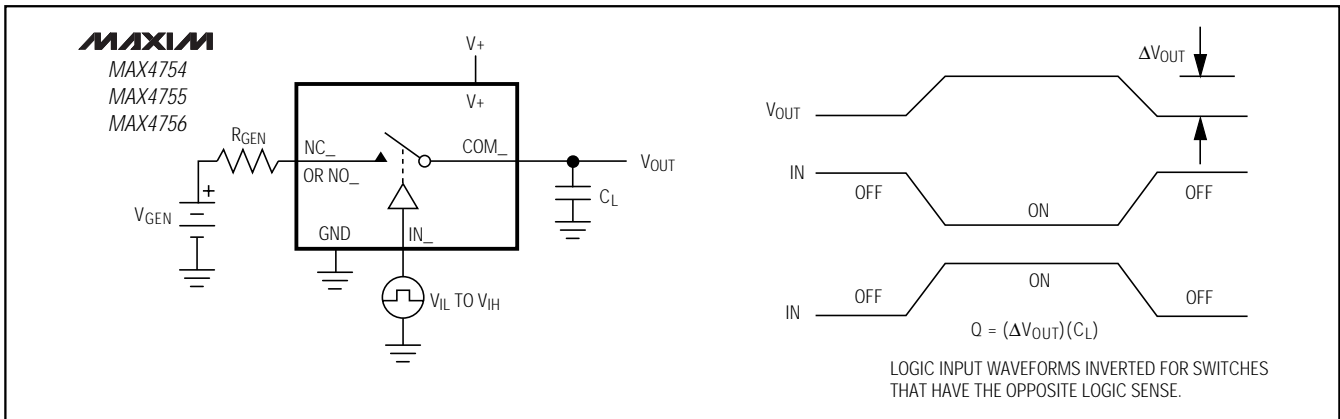

Figure 3. Charge Injection

0.5Ω, Quad SPDT Switches in UCSP/QFN

Timing Circuits/Timing Diagrams (continued)

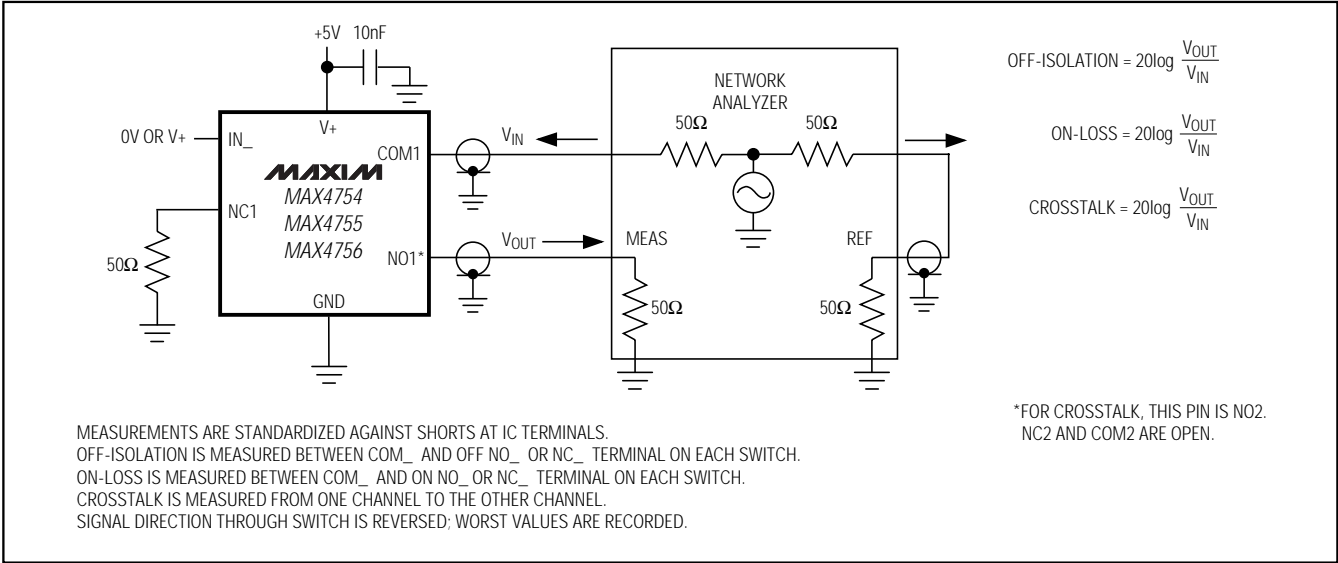

Figure 4. On-Loss, Off-Isolation, and Crosstalk

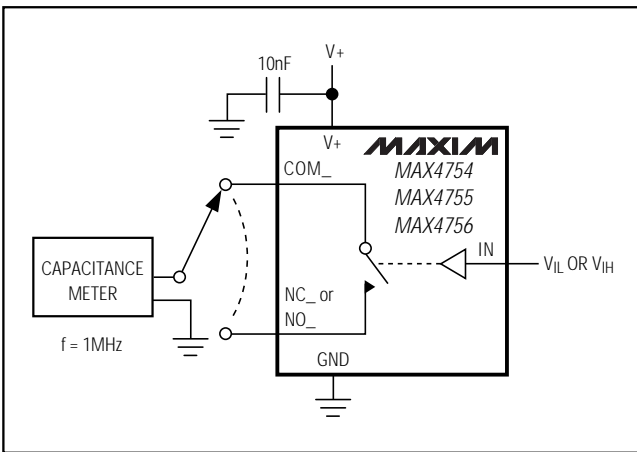

Figure 5. Channel On/Off-Capacitance

0.5Ω, Quad SPDT Switches in UCSP/QFN

Pin Configurations/Truth Tables

MAX4754/MAX4755/MAX4756

TOP VIEW
(BUMP SIDE DOWN)

MAXIM
MAX4754/MAX4755/MAX4756

() FOR MAX4756. **UCSP**

INA	NO1/NO2	NC1/NC2	NO3/NO4	NC3/NC4
LOW	OFF	ON	—	—
HIGH	ON	OFF	—	—
INB				
LOW	—	—	OFF	ON
HIGH	—	—	ON	OFF

MAXIM
MAX4754
MAX4755
MAX4756

THIN QFN

NOTE: EXPOSED PADDLE CONNECTED TO GND.

EN	INA	NO_	NC_
LOW	LOW	OFF	ON
LOW	HIGH	ON	OFF
HIGH	X	OFF	OFF
HIGH	X	OFF	OFF

Chip Information

TRANSISTOR COUNT: 496

PROCESS: CMOS

0.5Ω, Quad SPDT Switches in UCSP/QFN

Package Information

(The package drawing(s) in this data sheet may not reflect the most current specifications. For the latest package outline information, go to www.maxim-ic.com/packages.)

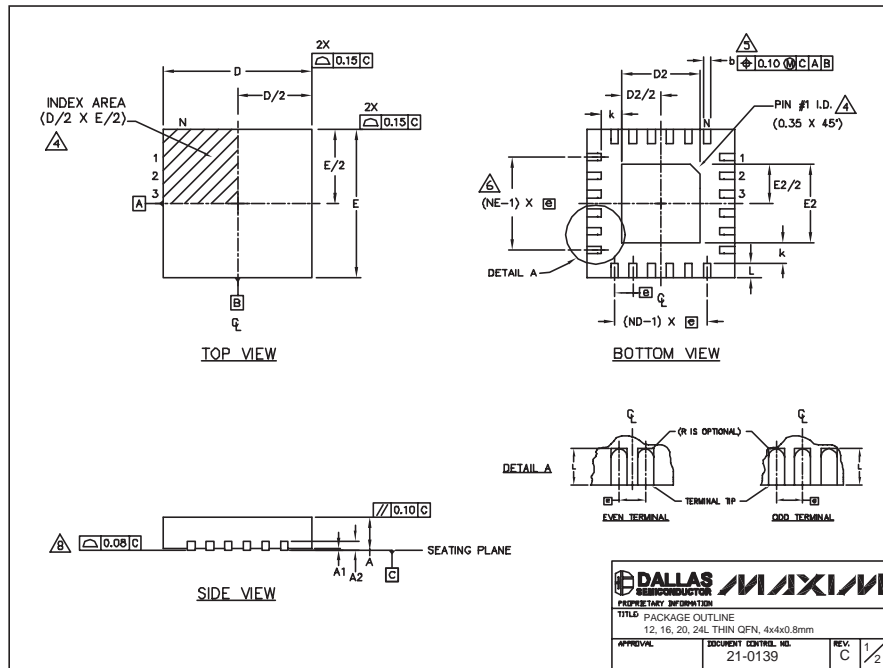

COMMON DIMENSIONS												
PKG REF.	12L 4x4			16L 4x4			20L 4x4			24L 4x4		
	MIN.	NDM.	MAX.	MIN.	NDM.	MAX.	MIN.	NDM.	MAX.	MIN.	NDM.	MAX.
A	0.70	0.75	0.80	0.70	0.75	0.80	0.70	0.75	0.80	0.70	0.75	0.80
AL	0.0	0.02	0.05	0.0	0.02	0.05	0.0	0.02	0.05	0.0	0.02	0.05
A2	0.20 REF.			0.20 REF.			0.20 REF.			0.20 REF.		
b	0.25	0.30	0.35	0.25	0.30	0.35	0.20	0.25	0.30	0.18	0.23	0.30
D	3.90	4.00	4.10	3.90	4.00	4.10	3.90	4.00	4.10	3.90	4.00	4.10
E	3.90	4.00	4.10	3.90	4.00	4.10	3.90	4.00	4.10	3.90	4.00	4.10
e	0.80 BSC.			0.65 BSC.			0.50 BSC.			0.50 BSC.		
k	0.25	-	-	0.25	-	-	0.25	-	-	0.25	-	-
L	0.45	0.55	0.65	0.45	0.55	0.65	0.45	0.55	0.65	0.30	0.40	0.50
N	12			16			20			24		
ND	3			4			5			6		
NE	3			4			5			6		
WGGC TOP	VGGB			WGGC			WGGD-1			WGGD-2		

EXPOSED PAD VARIATIONS									
PKG CODES	D2			E2			DOWN BENDS ALLOWED		
	MIN.	NDM.	MAX.	MIN.	NDM.	MAX.			
T1244-2	1.95	2.10	2.25	1.95	2.10	2.25	NO		
T1244-3	1.95	2.10	2.25	1.95	2.10	2.25	YES		
T1244-4	1.95	2.10	2.25	1.95	2.10	2.25	NO		
T1644-2	1.95	2.10	2.25	1.95	2.10	2.25	NO		
T1644-3	1.95	2.10	2.25	1.95	2.10	2.25	YES		
T1644-4	1.95	2.10	2.25	1.95	2.10	2.25	NO		
T2044-1	1.95	2.10	2.25	1.95	2.10	2.25	NO		
T2044-2	1.95	2.10	2.25	1.95	2.10	2.25	YES		
T2044-3	1.95	2.10	2.25	1.95	2.10	2.25	NO		
T2444-1	2.45	2.60	2.63	2.45	2.60	2.63	NO		
T2444-2	1.95	2.10	2.25	1.95	2.10	2.25	YES		
T2444-3	2.45	2.60	2.63	2.45	2.60	2.63	YES		
T2444-4	2.45	2.60	2.63	2.45	2.60	2.63	NO		

NOTES:

- DIMENSIONING & TOLERANCING CONFORM TO ASME Y14.5M-1994.
- ALL DIMENSIONS ARE IN MILLIMETERS, ANGLES ARE IN DEGREES.
- N IS THE TOTAL NUMBER OF TERMINALS.
- THE TERMINAL #1 IDENTIFIER AND TERMINAL NUMBERING CONVENTION SHALL CONFORM TO JEDEC 95-1 SFP-012. DETAILS OF TERMINAL #1 IDENTIFIER ARE OPTIONAL, BUT MUST BE LOCATED WITHIN THE ZONE INDICATED. THE TERMINAL #1 IDENTIFIER MAY BE EITHER A MOLD OR MARKED FEATURE.
- DIMENSION b APPLIES TO METALLIZED TERMINAL AND IS MEASURED BETWEEN 0.25 mm AND 0.30 mm FROM TERMINAL TIP.
- ND AND NE REFER TO THE NUMBER OF TERMINALS ON EACH D AND E SIDE RESPECTIVELY.
- DEPOPULATION IS POSSIBLE IN A SYMMETRICAL FASHION.
- COPLANARITY APPLIES TO THE EXPOSED HEAT SINK SLUG AS WELL AS THE TERMINALS.
- DRAWING CONFORMS TO JEDEC M2220, EXCEPT FOR T2444-1, T2444-3 AND T2444-4.

0.5Ω, Quad SPDT Switches in UCSP/QFN

Package Information (continued)

(The package drawing(s) in this data sheet may not reflect the most current specifications. For the latest package outline information, go to www.maxim-ic.com/packages.)

MAX4754/MAX4755/MAX4756

TOP VIEW

COMMON DIMENSIONS	
A	0.62±0.05-0.08
A1	0.29±0.02
A2	0.33 REF.
b	∅0.35±0.03
D1	1.50 BASIC
E1	1.50 BASIC
e	0.50 BASIC
SD	0.25 BASIC
SE	0.25 BASIC

PKG. CODE	VARIABLE DIMENSIONS		DEPOPULATED SOLDER BALLS
	D	E	
B16-1	2.02±0.05	2.02±0.05	NONE
B16-2	2.02±0.05	2.02±0.05	B3, C3
B16-3	2.02±0.05	2.02±0.05	B3, C2
B16-4	2.02±0.05	2.02±0.05	B2, C3
B16-5	2.02±0.05	2.02±0.05	B2, B3, C2, C3
B16-6	2.02±0.05	2.02±0.05	C3

NOTES:

- ALL DIMENSIONS ARE IN MILLIMETERS.
- PRODUCT MARKING: NUMBER OF CHARACTERS AND LINES VARY PER PRODUCT.

SIDE VIEW

BOTTOM VIEW

DALLAS SEMICONDUCTOR			MAXIM		
PROPRIETARY INFORMATION					
TITLE:					
PACKAGE OUTLINE, 4x4 UCSP					
APPROVAL	DOCUMENT CONTROL NO.	REV.	1/1		
	21-0101	H			

Maxim cannot assume responsibility for use of any circuitry other than circuitry entirely embodied in a Maxim product. No circuit patent licenses are implied. Maxim reserves the right to change the circuitry and specifications without notice at any time.

Maxim Integrated Products, 120 San Gabriel Drive, Sunnyvale, CA 94086 408-737-7600 13