



# High-Current, 10Ω, SPST, CMOS Analog Switches

**MAX4655-MAX4658**

## General Description

Maxim's MAX4655-MAX4658 are medium-voltage CMOS analog switches with low on-resistance of 10Ω max, specifically designed to handle large switch currents. With a switch capability of up to 400mA peak current and 300mA continuous current (MAX4655/MAX4656), and up to 300mA peak current and 150mA continuous current (MAX4657/MAX4658), these parts can switch loads as low as 25Ω. They can replace reed relays with a million times the speed and virtually unlimited number of lifetime cycles. Normal power consumption is only 3mW, whether the switch is on or off. These parts are TTL/CMOS compatible and will switch any voltage within its power-supply range.

These are SPST (single-pole/single-throw) switches. The MAX4655/MAX4657 are normally closed (NC), while the MAX4656/MAX4658 are normally open (NO). The difference between the MAX4655/MAX4656 and the MAX4657/MAX4658 is in the power dissipation of their packages. Refer to the *Absolute Maximum Ratings* and the *Electrical Characteristics*.

The MAX4655-MAX4658 power-supply range is from ±4.5V to ±20V for dual-supply operation and +9V to +40V for single-supply operation. These switches can operate from any combination of supplies, within a 40V V+ to V- range. They conduct equally well in either direction and can handle rail-to-rail analog signals. The off-leakage current is only 1nA max at T<sub>A</sub> = +25°C. They are available in 8-pin μMAX®, TDFN, and SO packages, with exposed paddle options for high-power applications.

## Applications

- Relay Replacement
- Test Equipment
- Communication Systems
- xDSL Modems
- PBX, PABX Systems
- Audio Signal Routing
- Audio Systems
- PC Multimedia Boards
- Redundant/Backup Systems

μMAX is a registered trademark of Maxim Integrated Products, Inc.

## Features

- ◆ High Continuous Current Handling  
300mA (MAX4655/MAX4656)  
150mA (MAX4657/MAX4658)
- ◆ High Peak Current Handling  
400mA (MAX4655/MAX4656)  
300mA (MAX4657/MAX4658)
- ◆ 10Ω (max) On-Resistance (±15V supplies)
- ◆ V<sub>L</sub> Not Required
- ◆ 1Ω (max) R<sub>ON</sub> Flatness over Specified Signal Range
- ◆ Rail-to-Rail Signal Handling
- ◆ +12V Single Supply or ±15V Dual Supply Operation
- ◆ Pin Compatible with DG417, DG418

## Ordering Information

PART	TEMP RANGE	PIN-PACKAGE	TOP MARK
MAX4655ETA	-40°C to +85°C	8 TDFN-EP*	AKT
MAX4655EUA	-40°C to +85°C	8 μMAX	AAAL
MAX4655ESA	-40°C to +85°C	8 SO	—
MAX4656ETA	-40°C to +85°C	8 TDFN-EP*	AKU
MAX4656EUA	-40°C to +85°C	8 μMAX	AAAM
MAX4656ESA	-40°C to +85°C	8 SO	—
MAX4657EUA	-40°C to +85°C	8 μMAX	—
MAX4657ESA	-40°C to +85°C	8 SO	—
MAX4658EUA	-40°C to +85°C	8 μMAX	—
MAX4658ESA	-40°C to +85°C	8 SO	—

\*EP = Exposed paddle.

## Pin Configurations/

## Functional Diagrams/Truth Tables

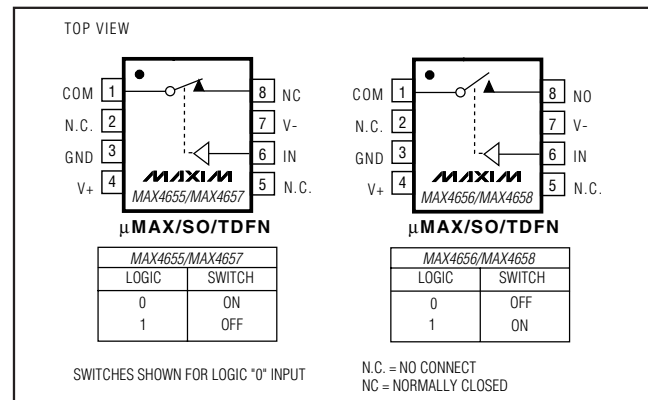

# High-Current, 10Ω, SPST, CMOS Analog Switches

## ABSOLUTE MAXIMUM RATINGS

V+ to GND .....	-0.3V to +44V
V- to GND .....	-44V to +0.3V
V+ to V- .....	-0.3V to +44V
All Other Pins to GND (Note 1) .....	V- - 0.3V to V+ + 0.3V
Continuous Current, COM, NO, NC (MAX4655/MAX4656) .....	±300mA
Continuous Current, COM, NO, NC (MAX4657/MAX4658) .....	±150mA
Continuous Current, IN .....	±30mA
Peak Current, COM, NO, NC (pulsed at 1ms, 10% duty cycle) MAX4655/MAX4656 .....	±400mA
(pulsed at 1ms, 10% duty cycle) MAX4657/MAX4658 .....	±300mA

Continuous Power Dissipation (T <sub>A</sub> = +70°C)	
8-Pin TDFN (derate 24.4mW/°C above +70°C) .....	1951mW
8-Pin μMAX-EP (derate 10.3mW/°C above +70°C)	
MAX4655/MAX4656 .....	825mW
8-Pin μMAX (derate 4.50mW/°C above +70°C)	
MAX4657/MAX4658 .....	362mW
8-Pin SO-EP (derate 18.9mW/°C above +70°C)	
MAX4655/MAX4656 .....	1509mW
8-Pin SO (derate 5.88mW/°C above +70°C)	
MAX4657/MAX4658 .....	471mW
Operating Temperature Ranges	
MAX4655-MAX4658 .....	-40°C to +85°C
Junction Temperature .....	+150°C
Storage Temperature Range .....	-65°C to +150°C
Lead Temperature (soldering, 10s) .....	+300°C

**Note 1:** Signals on NC, NO, COM, or IN exceeding V+ or V- will be clamped by internal diodes. Limit forward diode current to maximum current rating.

Stresses beyond those listed under "Absolute Maximum Ratings" may cause permanent damage to the device. These are stress ratings only, and functional operation of the device at these or any other conditions beyond those indicated in the operational sections of the specifications is not implied. Exposure to absolute maximum rating conditions for extended periods may affect device reliability.

## ELECTRICAL CHARACTERISTICS—Dual Supplies

(V+ = +15V, V- = -15V, V<sub>IH</sub> = 2.4V, V<sub>IL</sub> = 0.8V, T<sub>A</sub> = T<sub>MIN</sub> to T<sub>MAX</sub>, unless otherwise noted. Typical values are at T<sub>A</sub> = +25°C.) (Notes 2, 7, 8)

PARAMETER	SYMBOL	CONDITIONS	T <sub>A</sub>	MIN	TYP	MAX	UNITS
<b>ANALOG SWITCH</b>							
Analog Signal Range	V <sub>NO</sub> , V <sub>NC</sub> , V <sub>COM</sub>			V-		V+	V
On-Resistance	R <sub>ON</sub>	I <sub>COM</sub> = 100mA; V <sub>NO</sub> or V <sub>NC</sub> = ±10V	+25°C		7	10	Ω
			T <sub>MIN</sub> to T <sub>MAX</sub>			15	
On-Resistance Flatness (Note 3)	R <sub>FLAT(ON)</sub>	I <sub>COM</sub> = 100mA; V <sub>NO</sub> or V <sub>NC</sub> = -5V, 0, +5V	+25°C		0.3	1	Ω
			T <sub>MIN</sub> to T <sub>MAX</sub>			1.5	
NO or NC Off-Leakage Current (Note 4)	I <sub>NO(OFF)</sub> or I <sub>NC(OFF)</sub>	V <sub>COM</sub> = +14.5V, -14.5V; V <sub>NO</sub> or V <sub>NC</sub> = -14.5V, +14.5V	+25°C	-1	0.01	+1	nA
			T <sub>MIN</sub> to T <sub>MAX</sub>	-10		10	
COM Off-Leakage Current (Note 4)	I <sub>COM(OFF)</sub>	V <sub>COM</sub> = +14.5V, -14.5V; V <sub>NO</sub> or V <sub>NC</sub> = -14.5V, +14.5V	+25°C	-1	0.01	+1	nA
			T <sub>MIN</sub> to T <sub>MAX</sub>	-10		+10	
COM On-Leakage Current (Note 4)	I <sub>COM(ON)</sub>	V <sub>COM</sub> = +14.5V, -14.5V; V <sub>NO</sub> or V <sub>NC</sub> = +14.5V, -14.5V, or floating	+25°C	-2		+2	nA
			T <sub>MIN</sub> to T <sub>MAX</sub>	-20		+20	
<b>DYNAMIC CHARACTERISTICS</b>							
Turn-On Time	t <sub>ON</sub>	V <sub>NO</sub> or V <sub>NC</sub> = 10V; R <sub>L</sub> = 50Ω; MAX4655/4656, R <sub>L</sub> = 100Ω; MAX4657/4658, C <sub>L</sub> = 35pF; Figure 3	+25°C		110	200	ns
			T <sub>MIN</sub> to T <sub>MAX</sub>			300	
Turn-Off Time	t <sub>OFF</sub>	V <sub>NO</sub> or V <sub>NC</sub> = 10V; R <sub>L</sub> = 50Ω; MAX4655/4656, R <sub>L</sub> = 100Ω; MAX4657/4658, C <sub>L</sub> = 35pF; Figure 3	+25°C		75	100	ns
			T <sub>MIN</sub> to T <sub>MAX</sub>			150	

# High-Current, 10Ω, SPST, CMOS Analog Switches

MAX4655-MAX4658

## ELECTRICAL CHARACTERISTICS—Dual Supplies (continued)

(V+ = +15V, V- = -15V, VIH = 2.4V, VIL = 0.8V, TA = TMIN to TMAX, unless otherwise noted. Typical values are at TA = +25°C.)  
(Notes 2, 7, 8)

PARAMETER	SYMBOL	CONDITIONS	TA	MIN	TYP	MAX	UNITS
Charge Injection	Q	VGEN = 0; RGEN = 0; CL = 1nF; Figure 4	+25°C		23		pC
-3dB Bandwidth	BW		+25°C		210		MHz
Off-Isolation (Note 5)	VISO	f = 1MHz; RL = 50Ω; Figure 5	+25°C		-77		dB
Total Harmonic Distortion	THD	f = 20Hz to 20kHz, VN_ = 5Vp-p; RL = 600Ω	+25°C		0.007		%
NO or NC Off-Capacitance	CNO(OFF), CNC(OFF)	f = 1MHz; Figure 6	+25°C		25		pF
COM Off-Capacitance	CCOM(OFF)	f = 1MHz; Figure 6	+25°C		25		pF
COM On-Capacitance	CCOM(ON)	f = 1MHz; Figure 7	+25°C		67		pF
<b>DIGITAL I/O</b>							
Input Logic High	VIH		TMIN to TMAX	2.4			V
Input Logic Low	VIL		TMIN to TMAX			0.8	V
Input Leakage Current	IIN	VIN = 0.8V or 2.4V	TMIN to TMAX	-1		+1	μA
<b>POWER SUPPLY</b>							
Power-Supply Range			TMIN to TMAX	±4.5		±20	V
Positive Supply Current	I+	VIN = 0 or 5V, VN_ = 3V; ISWITCH = 200mA, MAX4655/4656; ISWITCH = 100mA, MAX4657/4658	+25°C		90	150	μA
			TMIN to TMAX			300	
Negative Supply Current	I-	VIN = 0 or 5V, VN_ = 3V; ISWITCH = 200mA, MAX4655/4656; ISWITCH = 100mA, MAX4657/4658	+25°C		10	50	μA
			TMIN to TMAX			100	
Ground Current	IGND	VIN = 0 or 5V, VN_ = 3V; ISWITCH = 200mA, MAX4655/4656; ISWITCH = 100mA, MAX4657/4658	+25°C		80	130	μA
			TMIN to TMAX			260	

# High-Current, 10Ω, SPST, CMOS Analog Switches

## ELECTRICAL CHARACTERISTICS—Single Supply

(V+ = +12V, V- = 0, VIH = 2.4V, VIL = 0.8V, TA = TMIN to TMAX, unless otherwise noted. Typical values are at TA = +25°C.) (Note 2)

PARAMETER	SYMBOL	CONDITIONS	TA	MIN	TYP	MAX	UNITS
<b>ANALOG SWITCH</b>							
Analog Signal Range	VIN		TMIN to TMAX	0		V+	V
On-Resistance	RON	ICOM = 50mA, VNO or VNC = 10V	+25°C		15	22	Ω
			TMIN to TMAX			33	
On-Resistance Flatness (Note 3)	RFLAT (ON)	ICOM = 50mA, VNO or VNC = 2V, 6V, 10V	+25°C		2.2	4	Ω
			TMIN to TMAX			5	
<b>DYNAMIC CHARACTERISTICS</b>							
Turn-On Time	tON	VNO or VNC = 10V; RL = 100Ω MAX4655/4656, RL = 200Ω MAX4657/4658, CL = 35pF; Figure 3	+25°C		140	200	ns
			TMIN to TMAX			300	
Turn-Off Time	tOFF	VNO or VNC = 10V; RL = 100Ω MAX4655/4656, RL = 200Ω MAX4657/4658, CL = 35pF; Figure 3	+25°C		65	125	ns
			TMIN to TMAX			200	
Charge Injection	Q	VGEN = 0; RGEN = 0; CL = 1nF; Figure 4	+25°C		1		pC
<b>POWER SUPPLY</b>							
Power-Supply Range	V+			9		40	V
Positive Supply Current (Note 6)	I+	VIN = 0 or 12V, ISWITCH = 100mA, MAX4655/4656; ISWITCH = 50mA, MAX4657/4658	+25°C		25	100	μA
			TMIN to TMAX			200	
		VIN = 0 or 5V, ISWITCH = 100mA, MAX4655/4656; ISWITCH = 50mA, MAX4657/4658	+25°C		46	125	
			TMIN to TMAX			200	

**Note 2:** The algebraic convention is used in this data sheet; the most negative value is shown in the minimum column.

**Note 3:** Flatness is defined as the difference between the maximum and minimum value of on-resistance as measured over the specified analog signal range.

**Note 4:** Leakage parameters are 100% tested at maximum rated hot temperature and guaranteed by correlation at TA = +25°C.

**Note 5:** Off-isolation = 20log10 [VCOM / (VNC or VNO)], VCOM = output, VNC or VNO = input to off switch.

**Note 6:** Guaranteed by testing with dual supplies.

**Note 7:** -40°C specifications are guaranteed by design.

**Note 8:** TDFN parts are tested at +25°C and guaranteed by design over the entire temperature range.

# High-Current, 10Ω, SPST, CMOS Analog Switches

## Typical Operating Characteristics

( $T_A = +25^\circ\text{C}$ , unless otherwise noted.)

MAX4655-MAX4658

**ON-RESISTANCE vs.  $V_{COM}$  (DUAL SUPPLIES)**

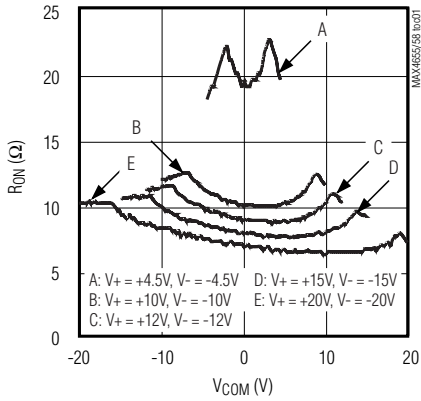

**ON-RESISTANCE vs.  $V_{COM}$  (SINGLE SUPPLY)**

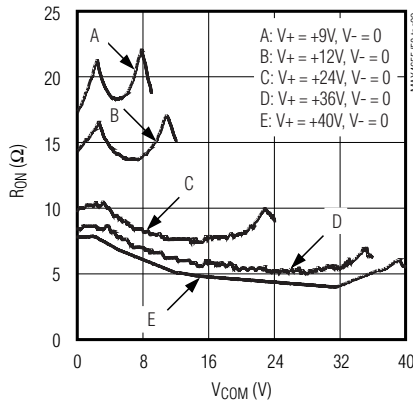

**ON-RESISTANCE vs.  $V_{COM}$  AND TEMPERATURE (DUAL SUPPLIES)**

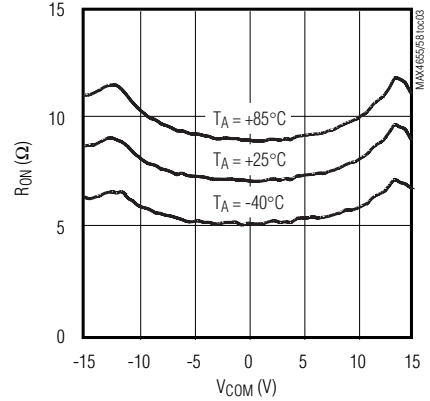

**ON-RESISTANCE vs.  $V_{COM}$  AND TEMPERATURE (SINGLE SUPPLY)**

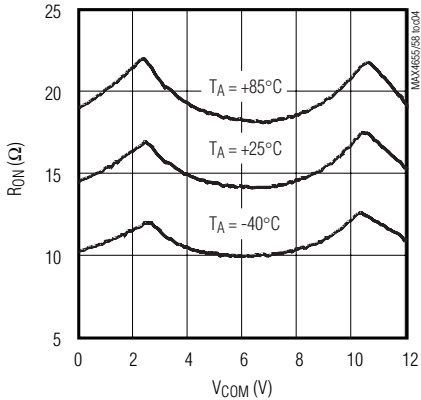

**LEAKAGE CURRENT vs. TEMPERATURE**

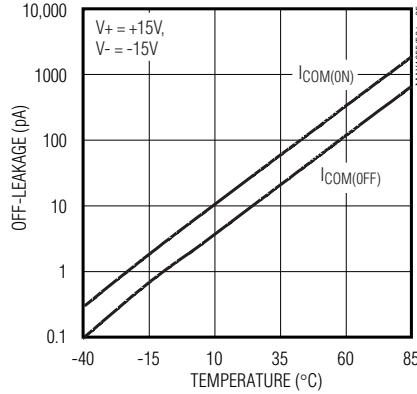

**CHARGE INJECTION vs.  $V_{COM}$**

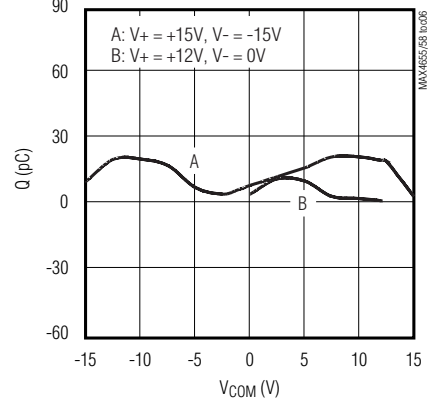

**SUPPLY CURRENT vs. SUPPLY VOLTAGE (SINGLE SUPPLY)**

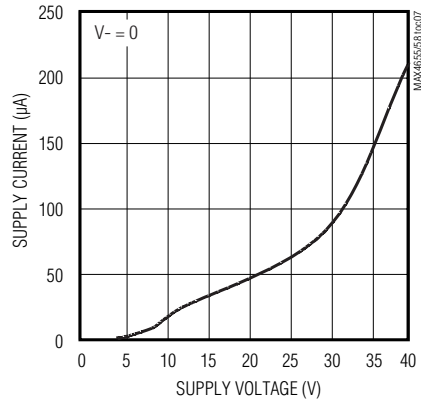

**SUPPLY CURRENT vs. SUPPLY VOLTAGE AND TEMPERATURE**

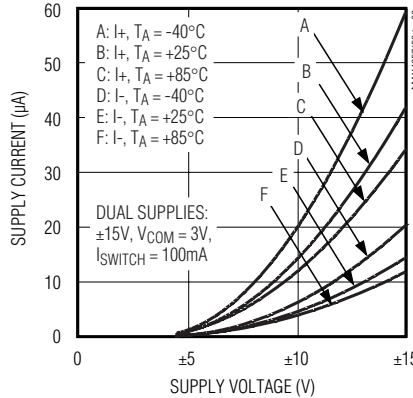

**TOTAL HARMONIC DISTORTION vs. FREQUENCY**

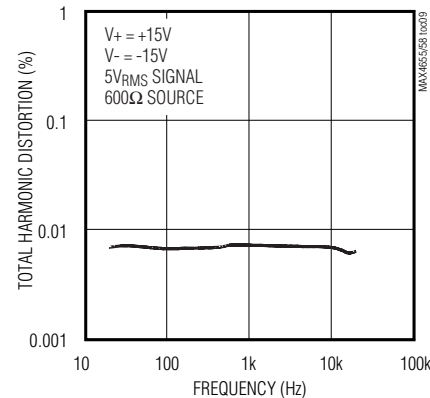

# High-Current, 10Ω, SPST, CMOS Analog Switches

## Typical Operating Characteristics (continued)

(T<sub>A</sub> = +25°C, unless otherwise noted.)

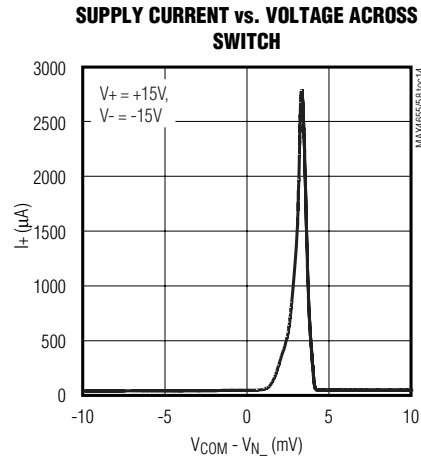
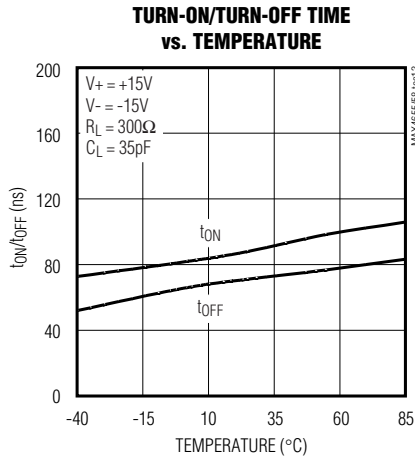
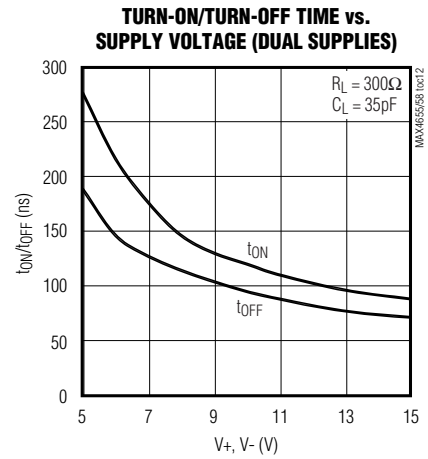
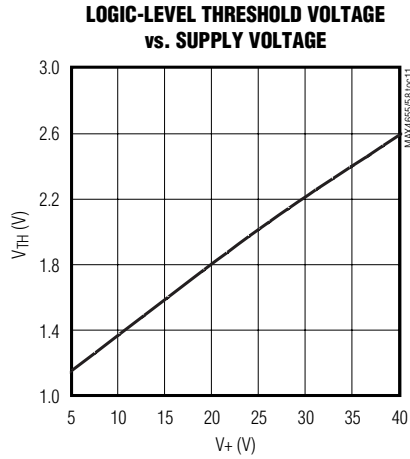
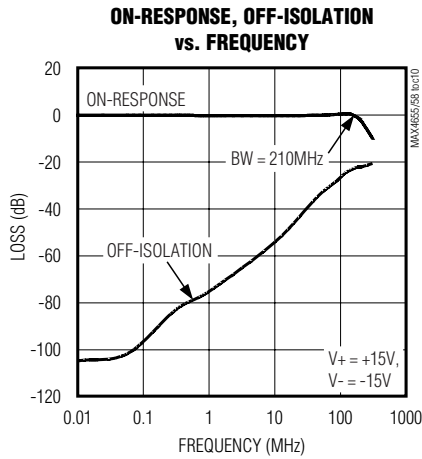

## Pin Description

PIN		NAME	FUNCTION
MAX4655/ MAX4657	MAX4656/ MAX4658		
1	1	COM	Analog Switch Common
2, 5	2, 5	N.C.	No Internal Connection
3	3	GND	Ground
4	4	V <sub>+</sub>	Positive Supply Voltage Input
6	6	IN	Digital Control Input
7	7	V <sub>-</sub>	Negative Supply Voltage Input
—	8	NO	Analog Switch Normally Open
8	—	NC	Analog Switch Normally Closed
EP	—	EP	Exposed Paddle. Connect EP to V <sub>+</sub> .

# High-Current, 10Ω, SPST, CMOS Analog Switches

MAX4655-MAX4658

## Detailed Description

The MAX4655–MAX4658 are single SPST CMOS analog switches. The CMOS switch construction provides rail-to-rail signal handling while consuming very little power. The switch is controlled by a TTL/CMOS level compatible digital input. The MAX4655/MAX4657 are normally closed switches, and the MAX4656/MAX4658 are normally open switches.

These devices can be operated with either single power supplies or dual power supplies. Operation at up to ±20V supplies allows users a wide switching dynamic range. Additionally, asymmetrical operation is possible to tailor performance to a particular application.

These switches have been specifically designed to handle high switch currents, up to 400mA peak current and 300mA continuous currents. In order to do this, a new technique is used to drive the body of the output N-channel device. (Note: the basic switch between the input NC/NO terminal, and the output common terminal consists of an N-channel MOSFET and a P-channel MOSFET in parallel.) The standard method limits operation to approximately a 600mV drop across the switch. More than 600mV causes an increase in  $I_{D_{ON}}$  leakage current (due to the turn-on of on-chip parasitic diodes) and an increase in  $V_+$  supply current. With the new sensing method, there is no limitation to the voltage drop across the switch. Current and voltage are limited only by the power dissipation rating of the package and the absolute maximum ratings of the switch.

When the analog input to output voltage drop is approximately 7mV there is an increase in power supply current from typically 90μA to 2mA within a 1mV to 7mV range, caused by the new sensing/driving circuitry.

## Applications Information

### Overvoltage Protection

Proper power-supply sequencing is recommended for all CMOS devices. Do not exceed the absolute maximum ratings, because stresses beyond the listed ratings can cause permanent damage to the devices. First, connect GND, followed by  $V_+$ ,  $V_-$ , and the remaining pins. If power-supply sequencing is not possible, add two small signal diodes (D1, D2) in series with supply pins (Figure 1). Adding diodes reduces the analog signal range to one diode drop below  $V_+$  and one diode drop above  $V_-$ , but does not affect the devices' low switch resistance and low leakage characteristics. Device operation is unchanged, and the difference between  $V_+$  and  $V_-$  should not exceed 44V. The protection diode for the negative supply is not required when  $V_-$  is connected to GND.

### Off-Isolation at High Frequencies

In 50Ω systems, the high-frequency on-response of these parts extends from DC to above 100MHz, with a typical loss of -2dB. When the switch is turned off, however, it behaves like a capacitor, and off-isolation decreases with increasing frequency. This effect is more pronounced with higher source and load impedances. Above 5MHz, circuit board layout becomes critical. The graphs shown in the *Typical Operating Characteristics* were taken using a 50Ω source and load connected with BNC connectors.

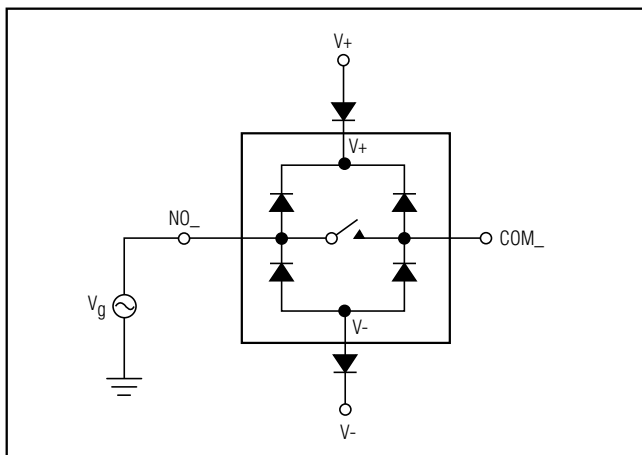

Figure 1. Overvoltage Protection Using Blocking Diodes

# High-Current, 10Ω, SPST, CMOS Analog Switches

## Test Circuits/Timing Diagrams

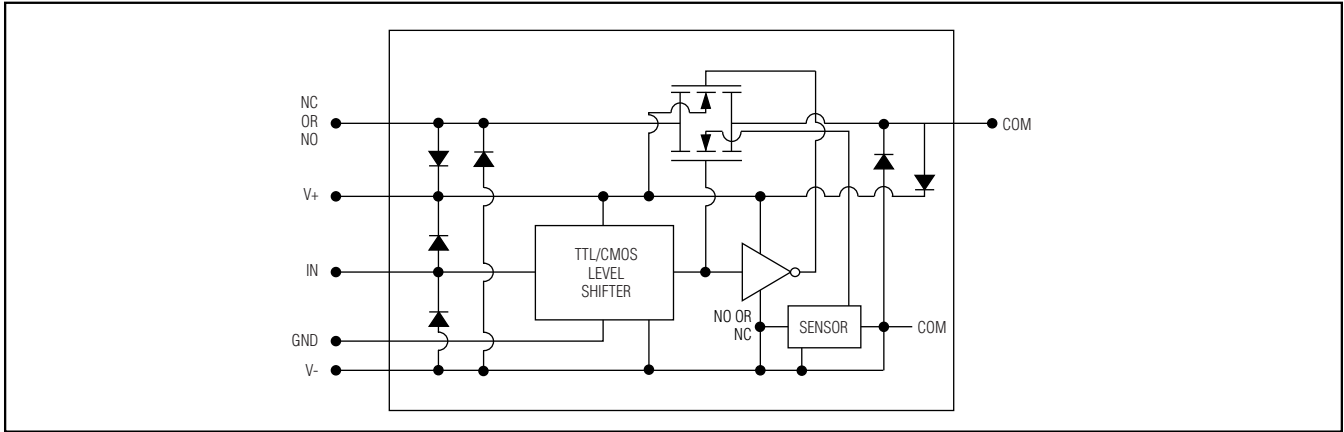

Figure 2. Block Diagram

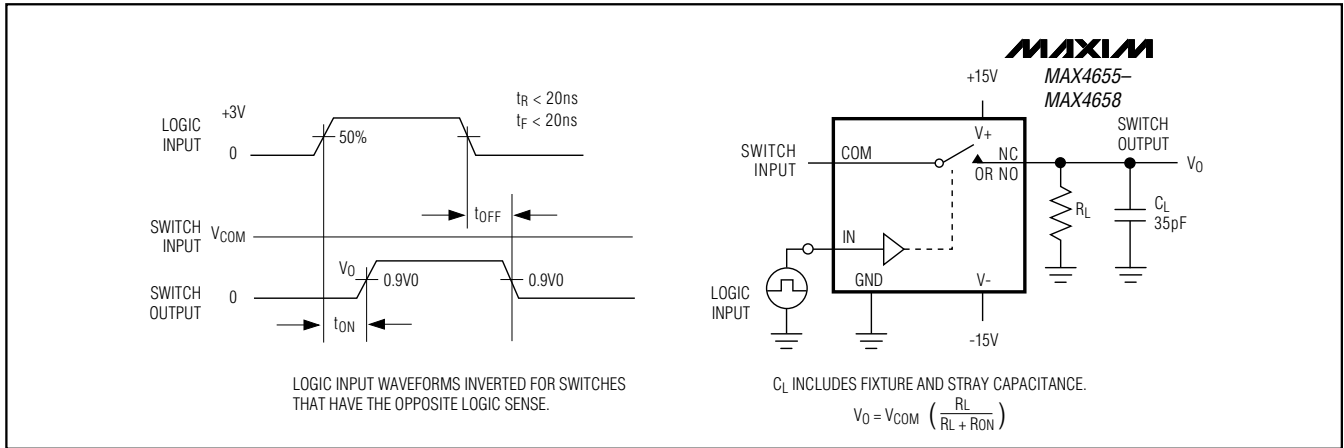

Figure 3. Switching Time

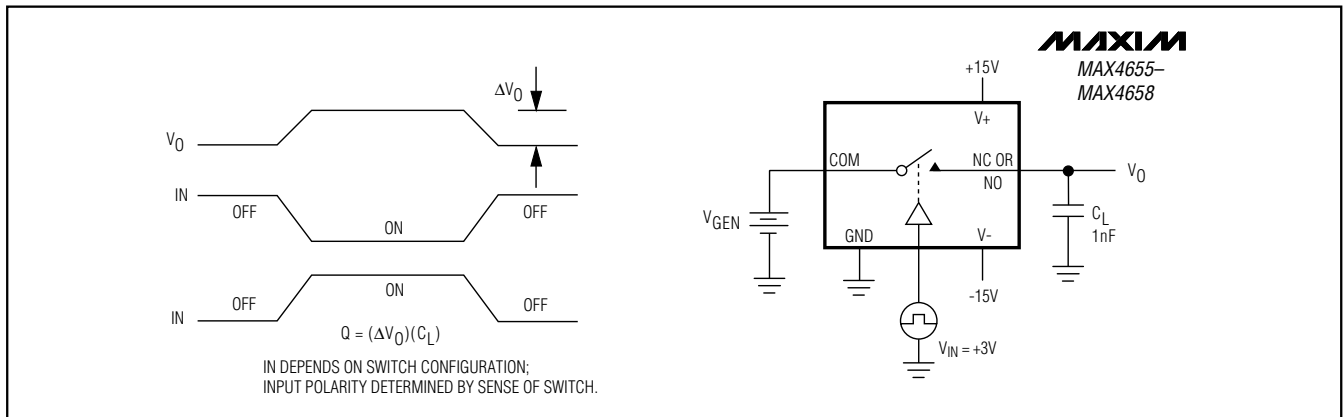

Figure 4. Charge Injection



# High-Current, 10Ω, SPST, CMOS Analog Switches

## Test Circuits/Timing Diagrams (continued)

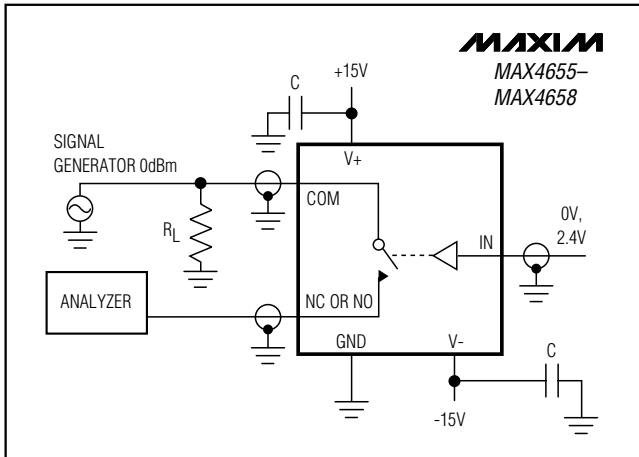

Figure 5. Off-Isolation

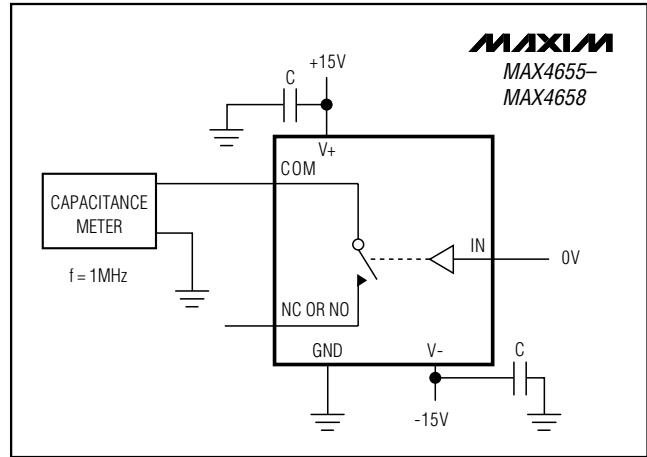

Figure 7. Channel On-Capacitance

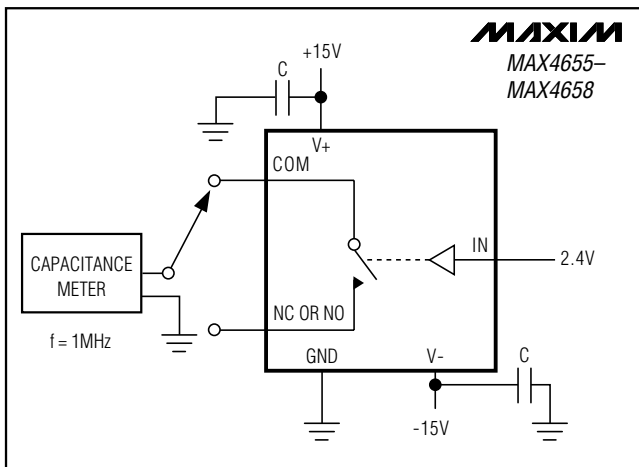

Figure 6. Channel Off-Capacitance

## Chip Information

TRANSISTOR COUNT: 45

PROCESS: CMOS

MAX4655-MAX4658

# High Current, 10Ω, SPST, CMOS Analog Switches

## Package Information

(The package drawing(s) in this data sheet may not reflect the most current specifications. For the latest package outline information go to [www.maxim-ic.com/packages](http://www.maxim-ic.com/packages).)

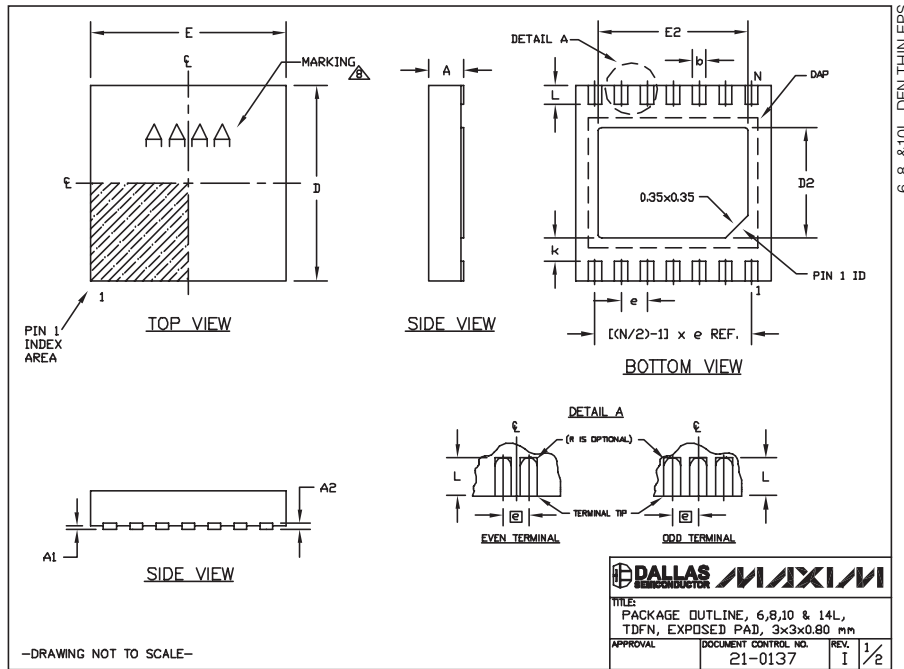

COMMON DIMENSIONS			PACKAGE VARIATIONS							
SYMBOL	MIN.	MAX.	PKG. CODE	N	D2	E2	e	JEDEC SPEC	b	[(N/2)-1] x e
A	0.70	0.80	T633-2	6	1.50±0.10	2.30±0.10	0.95 BSC	MO229 / WEEA	0.40±0.05	1.90 REF
D	2.90	3.10	T833-2	8	1.50±0.10	2.30±0.10	0.65 BSC	MO229 / WEEC	0.30±0.05	1.95 REF
E	2.90	3.10	T833-3	8	1.50±0.10	2.30±0.10	0.65 BSC	MO229 / WEEC	0.30±0.05	1.95 REF
A1	0.00	0.05	T1033-1	10	1.50±0.10	2.30±0.10	0.50 BSC	MO229 / WEED-3	0.25±0.05	2.00 REF
L	0.20	0.40	T1033-2	10	1.50±0.10	2.30±0.10	0.50 BSC	MO229 / WEED-3	0.25±0.05	2.00 REF
k	0.25 MIN.		T1433-1	14	1.70±0.10	2.30±0.10	0.40 BSC	----	0.20±0.05	2.40 REF
A2	0.20 REF.		T1433-2	14	1.70±0.10	2.30±0.10	0.40 BSC	----	0.20±0.05	2.40 REF

NOTES:

- ALL DIMENSIONS ARE IN mm. ANGLES IN DEGREES.
- COPLANARITY SHALL NOT EXCEED 0.08 mm.
- WARPAGE SHALL NOT EXCEED 0.10 mm.
- PACKAGE LENGTH/PACKAGE WIDTH ARE CONSIDERED AS SPECIAL CHARACTERISTIC(S).
- DRAWING CONFORMS TO JEDEC MO229, EXCEPT DIMENSIONS "D2" AND "E2", AND T1433-1 & T1433-2.
- "N" IS THE TOTAL NUMBER OF LEADS.
- NUMBER OF LEADS SHOWN ARE FOR REFERENCE ONLY.
- MARKING IS FOR PACKAGE ORIENTATION REFERENCE ONLY.

**DALLAS SEMICONDUCTOR** **MAXIM**

TITLE: PACKAGE OUTLINE, 6,8,10 & 14L, TDFN, EXPOSED PAD, 3x3x0.80 mm

APPROVAL: I 2/2

DOCUMENT CONTROL NO: 21-0137

REV: I 2/2

-DRAWING NOT TO SCALE-

# High Current, 10Ω, SPST, CMOS Analog Switches

## Package Information (continued)

(The package drawing(s) in this data sheet may not reflect the most current specifications. For the latest package outline information go to [www.maxim-ic.com/packages](http://www.maxim-ic.com/packages).)

**MAX4655-MAX4658**

8LUMAXD.EPS

DIM	INCHES		MILLIMETERS	
	MIN	MAX	MIN	MAX
A	-	0.043	-	1.10
A1	0.002	0.006	0.05	0.15
A2	0.030	0.037	0.75	0.95
b	0.010	0.014	0.25	0.36
c	0.005	0.007	0.13	0.18
D	0.116	0.120	2.95	3.05
e	0.0256 BSC		0.65 BSC	
E	0.116	0.120	2.95	3.05
H	0.188	0.198	4.78	5.03
L	0.016	0.026	0.41	0.66
α	0°	6°	0°	6°
S	0.0207 BSC		0.5250 BSC	

**NOTES:**  
 1. D&E DO NOT INCLUDE MOLD FLASH.  
 2. MOLD FLASH OR PROTRUSIONS NOT TO EXCEED 0.15MM (.006").  
 3. CONTROLLING DIMENSION: MILLIMETERS.  
 4. MEETS JEDEC MO-187C-AA.

**DALLAS SEMICONDUCTOR** **MAXIM**  
 PROPRIETARY INFORMATION  
 TITLE: PACKAGE OUTLINE, 8L uMAX/uSOP  
 APPROVAL: \_\_\_\_\_ DOCUMENT CONTROL NO. 21-0036 REV. J 1/1

# High Current, 10Ω, SPST, CMOS Analog Switches

## Package Information (continued)

(The package drawing(s) in this data sheet may not reflect the most current specifications. For the latest package outline information go to [www.maxim-ic.com/packages](http://www.maxim-ic.com/packages).)

SOICN EP5

DIM	INCHES		MILLIMETERS	
	MIN	MAX	MIN	MAX
A	0.053	0.069	1.35	1.75
A1	0.004	0.010	0.10	0.25
B	0.014	0.019	0.35	0.49
C	0.007	0.010	0.19	0.25
e	0.050 BSC		1.27 BSC	
E	0.150	0.157	3.80	4.00
H	0.228	0.244	5.80	6.20
L	0.016	0.050	0.40	1.27

VARIATIONS:

DIM	INCHES		MILLIMETERS		N	MS012
	MIN	MAX	MIN	MAX		
D	0.189	0.197	4.80	5.00	8	AA
D	0.337	0.344	8.55	8.75	14	AB
D	0.386	0.394	9.80	10.00	16	AC

**NOTES:**

1. D&E DO NOT INCLUDE MOLD FLASH.
2. MOLD FLASH OR PROTRUSIONS NOT TO EXCEED 0.15mm (.006").
3. LEADS TO BE COPLANAR WITHIN 0.10mm (.004").
4. CONTROLLING DIMENSION: MILLIMETERS.
5. MEETS JEDEC MS012.
6. N = NUMBER OF PINS.

<b>DALLAS SEMICONDUCTOR</b> <b>MAXIM</b>			
PROPRIETARY INFORMATION			
TITLE: <b>PACKAGE OUTLINE, .150" SOIC</b>			
APPROVAL	DOCUMENT CONTROL NO. <b>21-0041</b>	REV. <b>B</b>	1/1

## Revision History

Pages changed at Rev 4: 1, 2, 3, 6, 12

Maxim cannot assume responsibility for use of any circuitry other than circuitry entirely embodied in a Maxim product. No circuit patent licenses are implied. Maxim reserves the right to change the circuitry and specifications without notice at any time.

12 **Maxim Integrated Products, 120 San Gabriel Drive, Sunnyvale, CA 94086 408-737-7600**