

Single/Dual/Quad, High-Side Current-Sense Amplifiers with Internal Gain

General Description

The MAX4376/MAX4377/MAX4378 single, dual, and quad precision high-side current-sense amplifiers are available in space-saving packages. They feature buffered voltage outputs that eliminate the need for gain-setting resistors and are ideal for today's notebook computers, cell phones, and other systems where current monitoring is critical. These precision devices are offered in three fixed-gain versions of 20, 50, and 100:

GAIN	SUFFIX
20	T
50	F
100	H

For example, MAX4376TAUK is a single high-side amplifier with a gain of 20.

High-side current monitoring is especially useful in battery-powered systems since it does not interfere with the ground path of the battery charger. The input common-mode range of 0 to +28V is independent of the supply voltage and ensures that the current-sense feedback remains viable even when connected to a battery pack in deep discharge.

The full-scale current reading can be set by choosing the appropriate voltage gain and external-sense resistor. This capability offers a high level of integration and flexibility, resulting in a simple and compact current-sense solution.

The MAX4376/MAX4377/MAX4378 operate over a supply voltage range of +3V to +28V, draw 1mA of supply current per amplifier, and operate over the full automotive temperature range of -40°C to +125°C. These devices have a wide bandwidth of 2MHz, making them suitable for use inside battery-charger control loops. The buffered outputs drive up to 2mA of output current into a ground-referenced load.

The MAX4376 is available in a tiny 5-pin SOT23 package. The MAX4377/MAX4378 are available in space-saving 8-pin μ MAX® and 14-pin TSSOP packages, respectively.

Applications

Notebook Computers	Portable/Battery-Powered Systems
Current-Limited Power Supplies	Cell Phones
Fuel Gauges in PC	Smart Battery Packages
General-System/Board-Level Current Monitoring	Automotive Current Detect
Battery Chargers	Power Management Systems
	PA Bias Control

μ MAX is a registered trademark of Maxim Integrated Products, Inc.

Features

- ◆ Low-Cost, Single/Dual/Quad, High-Side Current-Sense Amplifiers
- ◆ $\pm 0.5\%$ Typical Full-Scale Accuracy
- ◆ +3V to +28V Supply Operation
- ◆ Adjustable Current-Sense Capability with External Sense Resistor
- ◆ Buffered Output Voltage with 2mA Drive
- ◆ 1mA (typ) Supply Current
- ◆ 2.0MHz Bandwidth (Gain = +20V/V)
- ◆ Automotive Temperature Range (-40°C to +125°C)
- ◆ High Accuracy +2V to +28V Common-Mode Range, Functional Down to 0V, Independent of Supply Voltage
- ◆ Three Gain Versions Available
 - +20V/V (MAX437_T)
 - +50V/V (MAX437_F)
 - +100V/V (MAX437_H)
- ◆ Available in Space-Saving 5-Pin SOT23 (Single), 8-Pin μ MAX (Dual), and 14-Pin TSSOP (Quad)

Ordering Information

PART	GAIN (+V/V)	TEMP RANGE	PIN-PACKAGE	TOP MARK
MAX4376TAUK+T	20	-40°C to +125°C	5 SOT23	ADOG
MAX4376TAUK/V+T	20	-40°C to +125°C	5 SOT23	—
MAX4376FAUK+T	50	-40°C to +125°C	5 SOT23	ADOH
MAX4376HAUK+T	100	-40°C to +125°C	5 SOT23	ADOI
MAX4376HAUK/V+T	100	-40°C to +125°C	5 SOT23	AFGO
MAX4376TASA+	20	-40°C to +125°C	8 SO	—
MAX4376FASA+	50	-40°C to +125°C	8 SO	—
MAX4376HASA+	100	-40°C to +125°C	8 SO	—

Ordering Information continued at end of data sheet.

+ Denotes a lead(Pb)-free/RoHS-compliant package.

/V denotes an automotive qualified part.

T = Tape and reel.

Pin Configurations

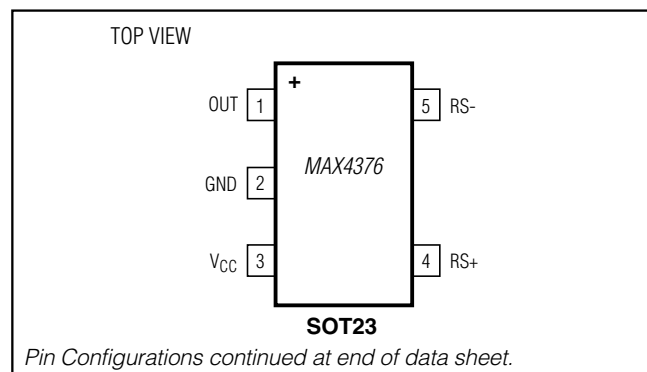

For pricing, delivery, and ordering information, please contact Maxim Direct at 1-888-629-4642, or visit Maxim's website at www.maximintegrated.com.

MAX4376/MAX4377/MAX4378

Single/Dual/Quad, High-Side Current-Sense Amplifiers with Internal Gain

ABSOLUTE MAXIMUM RATINGS

V _{CC} , RS+, RS- to GND	-0.3V to +30V	8-Pin SO (derate 5.88mW/°C above +70°C)	471mW
OUT to GND	-0.3V to (V _{CC} + 0.3V)	14-Pin SO (derate 8.33mW/°C above +70°C)	667mW
Differential Input Voltage (V _{RS+} - V _{RS-})	±8V	14-Pin TSSOP (derate 9.1mW/°C above +70°C)	727mW
Output Short Circuit to V _{CC}	Continuous	Operating Temperature Range	-40°C to +125°C
Output Short Circuit to GND	1s	Junction Temperature	+150°C
Current into Any Pin	±20mA	Storage Temperature Range	-65°C to +150°C
Continuous Power Dissipation (T _A = +70°C)		Lead Temperature (soldering, 10s)	+300°C
5-Pin SOT23 (derate 7.1mW/°C above +70°C)	571mW	Soldering Temperature (reflow)	+260°C
8-Pin μMAX (derate 4.5mW/°C above +70°C)	362mW		

Stresses beyond those listed under "Absolute Maximum Ratings" may cause permanent damage to the device. These are stress ratings only, and functional operation of the device at these or any other conditions beyond those indicated in the operational sections of the specifications is not implied. Exposure to absolute maximum rating conditions for extended periods may affect device reliability.

ELECTRICAL CHARACTERISTICS

(V_{RS+} = 0 to 28V, V_{SENSE} = (V_{RS+} - V_{RS-}) = 0V, V_{CC} = +3.0V to +28V, R_L = ∞, T_A = T_{MIN} to T_{MAX}, unless otherwise noted. Typical values are at T_A = 25°C.) (Note 1)

PARAMETER	SYMBOL	CONDITIONS		MIN	TYP	MAX	UNITS
Operating Voltage Range	V _{CC}	Guaranteed by PSR test		3		28	V
Common-Mode Input Range	V _{CM}	Guaranteed by total OUT voltage error test		0		28	V
Common-Mode Rejection	CMR	2V ≤ V _{RS+} ≤ 28V, V _{SENSE} = 100mV			90		dB
Supply Current per Amplifier	I _{CC}	V _{SENSE} = 5mV, V _{RS+} > 2.0V, V _{CC} = 12V			1	2.2	mA
Leakage Current	I _{RS+} , I _{RS-}	V _{CC} = 0V, V _{RS+} = 28V				8	μA
Input Bias Current	I _{RS+}	V _{RS+} > 2.0V		0		60	μA
		V _{RS+} ≤ 2.0V		-400		60	
	I _{RS-}	V _{RS+} > 2.0V		0		120	
		V _{RS+} ≤ 2.0V		-800		120	
Full-Scale Sense Voltage	V _{SENSE}				150		mV
Total OUT Voltage Error (Note 2)		I _{OUT} ≤ 2mA	V _{SENSE} = 100mV, V _{CC} = 12V, V _{RS+} = 12V			±6.75	%
			V _{SENSE} = 100mV, V _{CC} = 12V, T _A = +25°C, V _{RS+} = 12V	±0.5		±3.25	
			V _{SENSE} = 100mV, V _{CC} = 28V, V _{RS+} = 28V			±11	
			V _{SENSE} = 100mV, V _{CC} = 28V, V _{RS+} = 28V, T _A = +25°C	±0.5		±5	
			V _{SENSE} = 100mV, V _{CC} = 12V, V _{RS+} = 0.1V	±9		±32	
			V _{SENSE} = 6.25mV, V _{CC} = 12V, V _{RS+} = 12V (Note 3)	±7			
OUT High Voltage (Note 4)	(V _{CC} - V _{OUT})	V _{CC} = 3V, I _{OUT} = 2mA, V _{RS+} = 28V		0.9		1.2	V
OUT Low Voltage	V _{OL}	I _{OUT} = 200μA, V _{CC} = V _{RS+} = 12V, V _{SENSE} = 0V, T _A = +25°C		25		40	mV

MAX4376/MAX4377/MAX4378

Single/Dual/Quad, High-Side Current-Sense Amplifiers with Internal Gain

ELECTRICAL CHARACTERISTICS (continued)

($V_{RS+} = 0$ to 28V, $V_{SENSE} = (V_{RS+} - V_{RS-}) = 0$ V, $V_{CC} = +3.0$ V to +28V, $R_L = \infty$, $T_A = T_{MIN}$ to T_{MAX} , unless otherwise noted. Typical values are at $T_A = 25^\circ\text{C}$.) (Note 1)

PARAMETER	SYMBOL	CONDITIONS		MIN	TYP	MAX	UNITS	
Bandwidth	BW	$V_{CC} = 12$ V $V_{RS+} = 12$ V $C_{LOAD} = 15$ pF	$V_{SENSE} = 100$ mV (gain = +20V/V)		2		MHz	
			$V_{SENSE} = 100$ mV (gain = +50V/V)		1.7			
			$V_{SENSE} = 100$ mV (gain = +100V/V)		1.2			
			$V_{SENSE} = 6.25$ mV (Note 3)		0.5			
Slew Rate	SR	$V_{SENSE} = 20$ mV to 100mV, $C_{LOAD} = 15$ pF			10		V/ μ s	
Gain	A_V	MAX437_T			+20		V/V	
		MAX437_F			+50			
		MAX437_H			+100			
Gain Accuracy	ΔA_V	$V_{SENSE} = 10$ mV to 150mV, $V_{CC} = 12$ V, $I_{OUT} = 2$ mA, gain = 20 and 50, $V_{RS+} = 12$ V	$T_A = T_{MIN}$ to T_{MAX}			± 5.5	%	
			$T_A = +25^\circ\text{C}$		± 0.5	± 2.5		
		$V_{SENSE} = 10$ mV to 150mV, $V_{CC} = 20$ V, $I_{OUT} = 2$ mA, gain = 100, $V_{RS+} = 12$ V	$T_A = T_{MIN}$ to T_{MAX}			5.5		
			$T_A = +25^\circ\text{C}$		± 0.5	± 2.5		
OUT Setting Time to 1% of Final Value		$V_{CC} = 12$ V, $V_{RS+} = 12$ V, $C_{LOAD} = 15$ pF	$V_{SENSE} = 6.25$ mV to 100mV		400		ns	
			$V_{SENSE} = 100$ mV to 6.25mV		800			
Maximum Capacitive Load	C_{LOAD}	No sustained oscillation			1000		pF	
Output Resistance	R_{OUT}	$V_{SENSE} = 100$ mV			5		Ω	
Power-Supply Rejection	PSR	$V_{RS+} > 2$ V, $V_{OUT} = 1.6$ V, $V_{CC} = 3$ V to 28V		66	90		dB	
Power-Up Time to 1% of Final Value		$V_{SENSE} = 100$ mV, $C_{LOAD} = 15$ pF			2		μ s	
Saturation Recovery Time to 1% of Final Value		$V_{CC} = 12$ V, $V_{RS+} = 12$ V, $C_{LOAD} = 15$ pF, $V_{SENSE} = 100$ mV			1		μ s	
Reverse Recovery Time to 1% of Final Value		$V_{CC} = 12$ V, $V_{RS-} = 12$ V, $C_{LOAD} = 15$ pF, $V_{SENSE} = -100$ mV to +100mV			1		μ s	

Note 1: All devices are 100% production tested at $T_A = +25^\circ\text{C}$. All temperature limits are guaranteed by design.

Note 2: Total OUT Voltage Error is the sum of gain and offset errors.

Note 3: 6.25mV = 1/16 of 100mV full-scale sense voltage.

Note 4: V_{SENSE} such that V_{OUT} is in saturation.

MAX4376/MAX4377/MAX4378

Single/Dual/Quad, High-Side Current-Sense Amplifiers with Internal Gain

Typical Operating Characteristics

($V_{CC} = V_{RS+} = 12V$, $V_{SENSE} = 100mV$, $T_A = +25^{\circ}C$.)

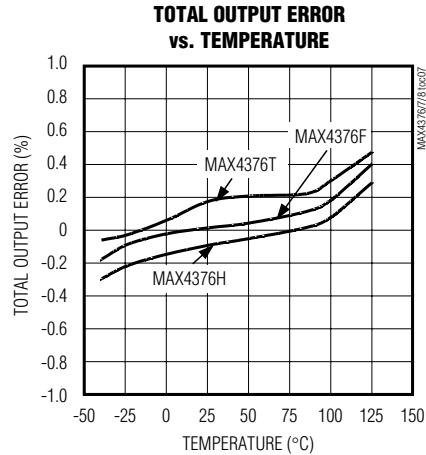
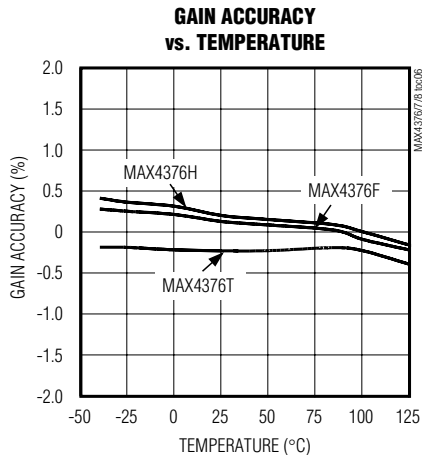
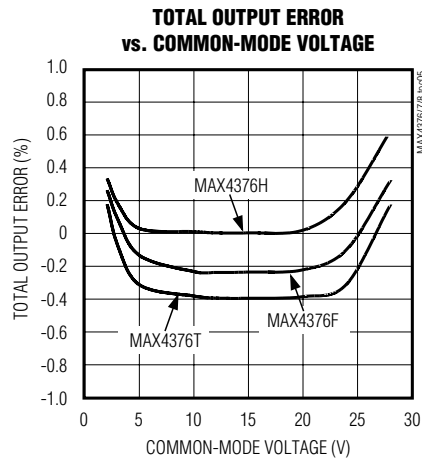
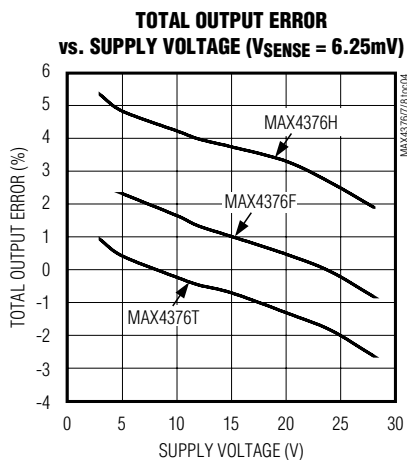
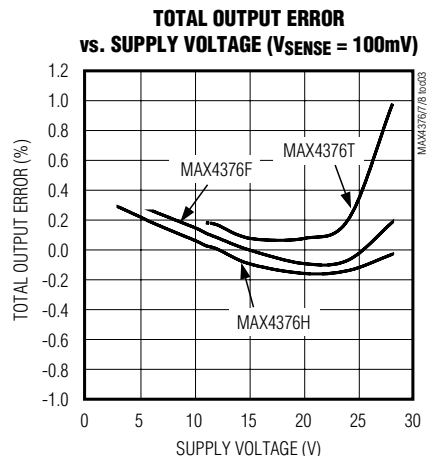
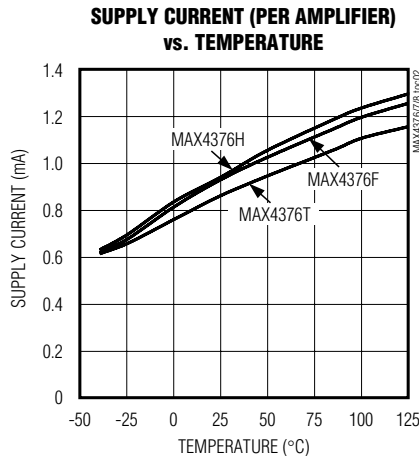
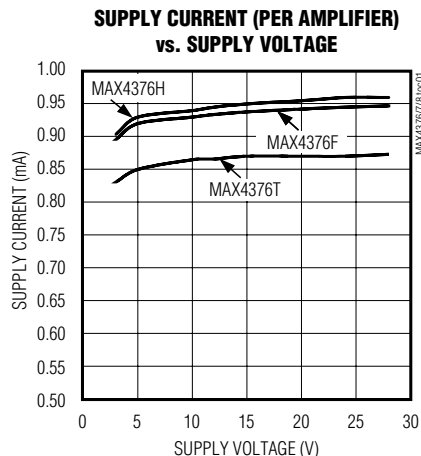

MAX4376/MAX4377/MAX4378

Single/Dual/Quad, High-Side Current-Sense Amplifiers with Internal Gain

Typical Operating Characteristics (continued)

($V_{CC} = V_{RS+} = 12V$, $V_{SENSE} = 100mV$, $T_A = +25^{\circ}C$.)

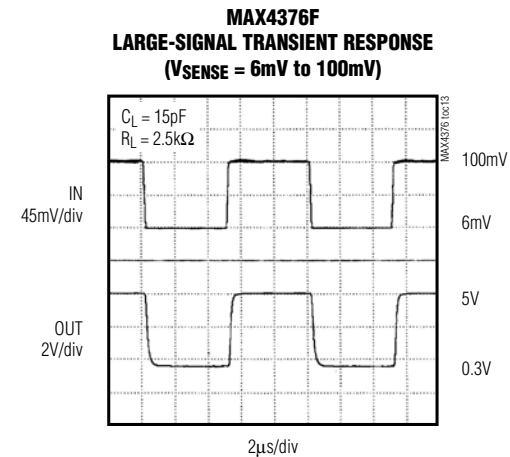
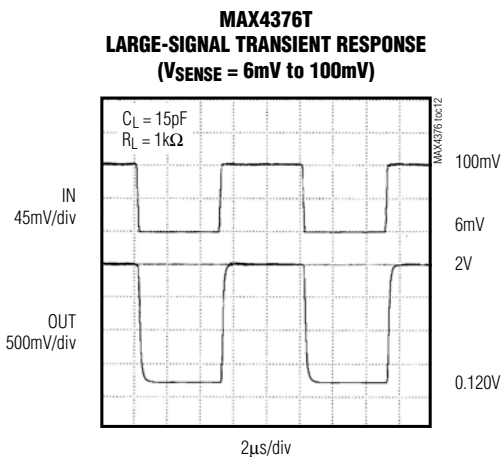
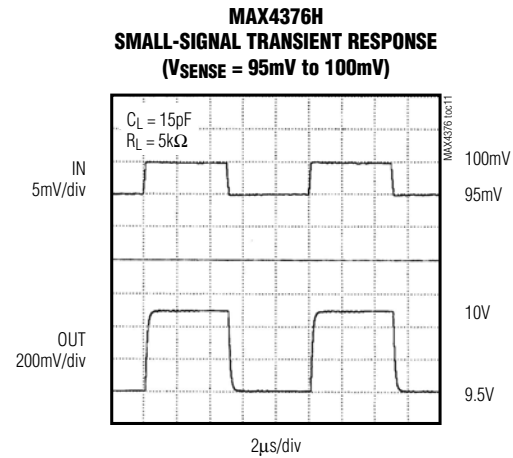
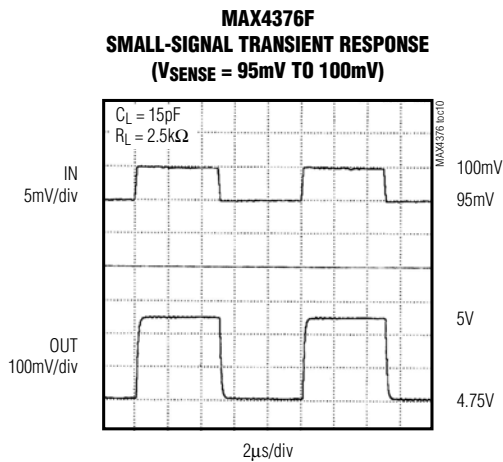
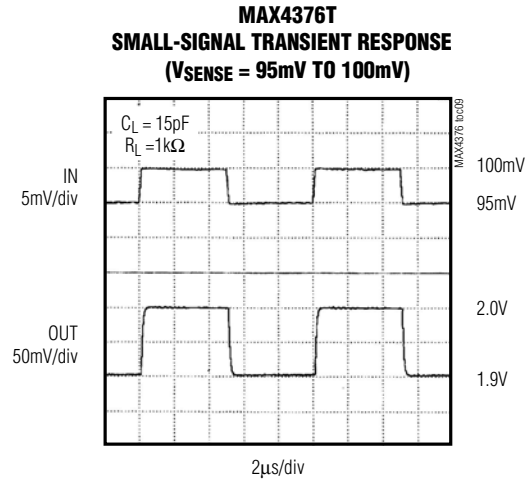
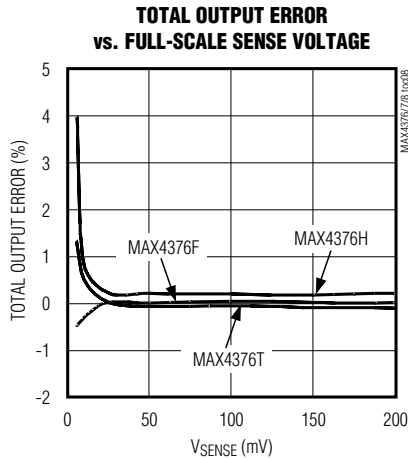

MAX4376/MAX4377/MAX4378

Single/Dual/Quad, High-Side Current-Sense Amplifiers with Internal Gain

Typical Operating Characteristics (continued)

($V_{CC} = V_{RS+} = 12V$, $V_{SENSE} = 100mV$, $T_A = +25^{\circ}C$.)

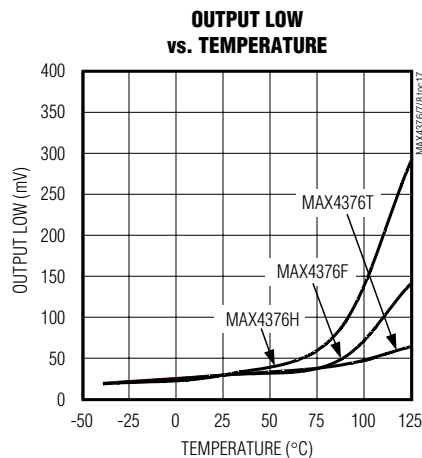
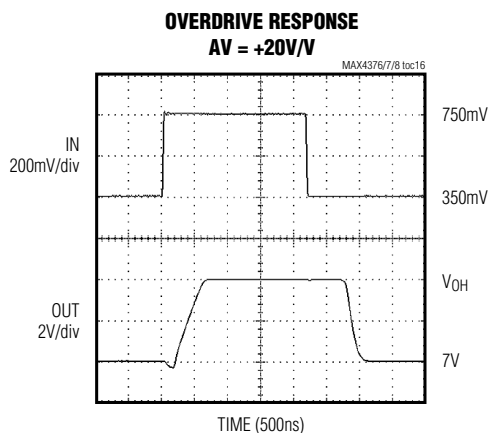
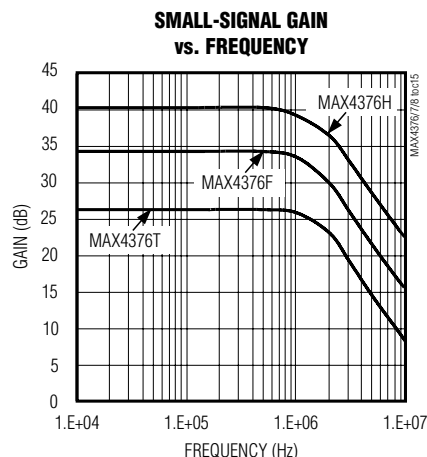
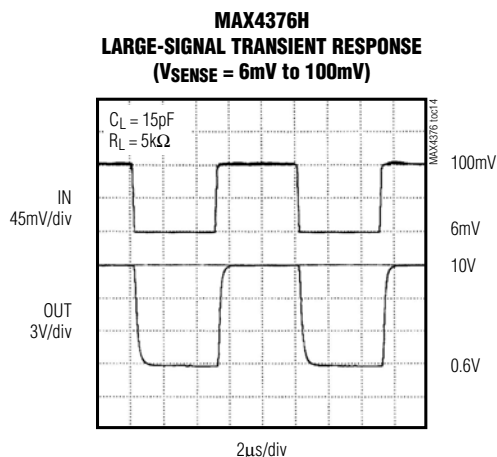

Pin Description

PIN				NAME	FUNCTION
MAX4376	MAX4376	MAX4377	MAX4378		
SOT23-5	SO-8	μ MAX-8/ SO-8	SO-14/ TSSOP-14		
1	4	1, 7	1, 7, 8, 14	OUT, OUT ₋	Output Voltage. V_{OUT-} is proportional to the magnitude of the sense voltage ($V_{RS+} - V_{RS-}$). V_{OUT-} is approximately zero when $V_{RS-} > V_{RS+}$ (no phase reversal).
2	3	4	11	GND	Ground
3	1	8	4	V _{CC}	Supply Voltage
4	8	3, 5	3, 5, 10, 12	RS ₊ , RS ₊	Power connection to the external sense resistor
5	6	2, 6	2, 6, 9, 13	RS ₋ , RS ₋	Load-side connection to the external sense resistor
—	2, 5, 7	—	—	N.C.	No Connection. Not internally connected.

MAX4376/MAX4377/MAX4378

Single/Dual/Quad, High-Side Current-Sense Amplifiers with Internal Gain

Detailed Description

The MAX4376/MAX4377/MAX4378 high-side current-sense amplifiers feature a 0 to +28V input common-mode range that is independent of supply voltage. This feature allows the monitoring of current out of a battery in deep discharge and also enables high-side current sensing at voltages greater than the supply voltage (VCC).

The MAX4376/MAX4377/MAX4378 operate as follows: current from the source flows through R_{SENSE} to the load (Figure 1). Since the internal sense amplifier's inverting input has high impedance, negligible current flows through RG2 (neglecting the input bias current). Therefore, the sense amplifier's inverting-input voltage equals V_{SOURCE} - (I_{LOAD})(R_{SENSE}).

The amplifier's open-loop gain forces its noninverting input to the same voltage as the inverting input. Therefore, the drop across RG1 equals (I_{LOAD})(R_{SENSE}). Since I_{RG1} flows through RG1, I_{RG1} = (I_{LOAD})(R_{SENSE})/RG1. The internal current mirror multiplies I_{RG1} by a current gain factor, β, to give I_{RGD} = β × I_{RG1}. Solving I_{RGD} = β × (I_{LOAD})(R_{SENSE})/RG1. Therefore:

$$V_{OUT} = \beta \times (R_{GD}/R_{G1})(R_{SENSE} \times I_{LOAD}) \times \text{amp gain}$$

where amp gain is 2, 5, or 10.

The part's gain equals (β × R_{GD} / R_{G1}) × amp gain.

Therefore:

$$V_{OUT} = (\text{GAIN})(R_{SENSE})(I_{LOAD})$$

where GAIN = 20 for MAX437_T.

GAIN = 50 for MAX437_F.

GAIN = 100 for MAX437_H.

Set the full-scale output range by selecting R_{SENSE} and the appropriate gain version of the MAX4376/MAX4377/MAX4378.

Applications Information

Recommended Component Values

The MAX4376/MAX4377/MAX4378 sense a wide variety of currents with different sense resistor values. Table 1 lists common resistor values for typical operation of the MAX4376/MAX4377/MAX4378.

Choosing R_{SENSE}

To measure lower currents more accurately, use a high value for R_{SENSE}. The high value develops a higher sense voltage that reduces offset voltage errors of the internal op amp.

In applications monitoring very high currents, R_{SENSE} must be able to dissipate the I²R losses. If the resistor's rated power dissipation is exceeded, its value may drift or it may fail altogether, causing a differential voltage across the terminals in excess of the absolute maximum ratings.

If I_{SENSE} has a large high-frequency component, minimize the inductance of R_{SENSE}. Wire-wound resistors have the highest inductance, metal-film resistors are somewhat better, and low-inductance metal-film resistors are best suited for these applications.

Bidirectional Current-Sense Amplifier

Systems such as laptop computers and other devices that have internal charge circuitry require a precise bidirectional current-sense amplifier to monitor accurately the battery's current regardless of polarity. Figure 2 shows the MAX4377 used as a bidirectional current monitor. This is useful for implementing either smart battery packs or fuel gauges.

Current Source Circuit

Figure 3 shows a block diagram using the MAX4376 with a switching regulator to make a current source.

MAX4376/MAX4377/MAX4378

Single/Dual/Quad, High-Side Current-Sense Amplifiers with Internal Gain

Table 1. Recommended Component Values

FULL-SCALE LOAD CURRENT, I_{LOAD} (A)	CURRENT-SENSE RESISTOR, R_{SENSE} (m Ω)	GAIN (+V/V)	FULL-SCALE OUTPUT VOLTAGE (FULL-SCALE $V_{SENSE} = 100\text{mV}$), V_{OUT} (V)
0.1	1000	20	2.0
		50	5.0
		100	10.0
1	100	20	2.0
		50	5.0
		100	10.0
5	20	20	2.0
		50	5.0
		100	10.0
10	10	20	2.0
		50	5.0
		100	10.0

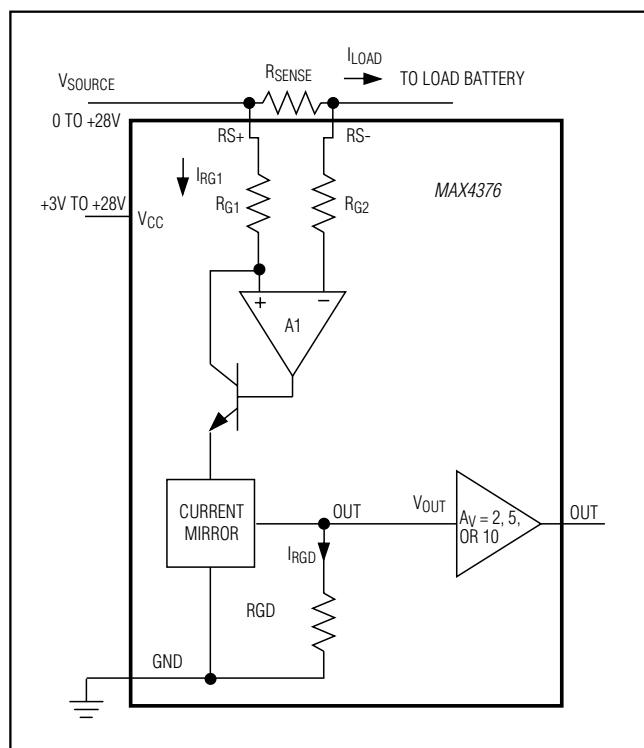

Figure 1. Functional Diagram

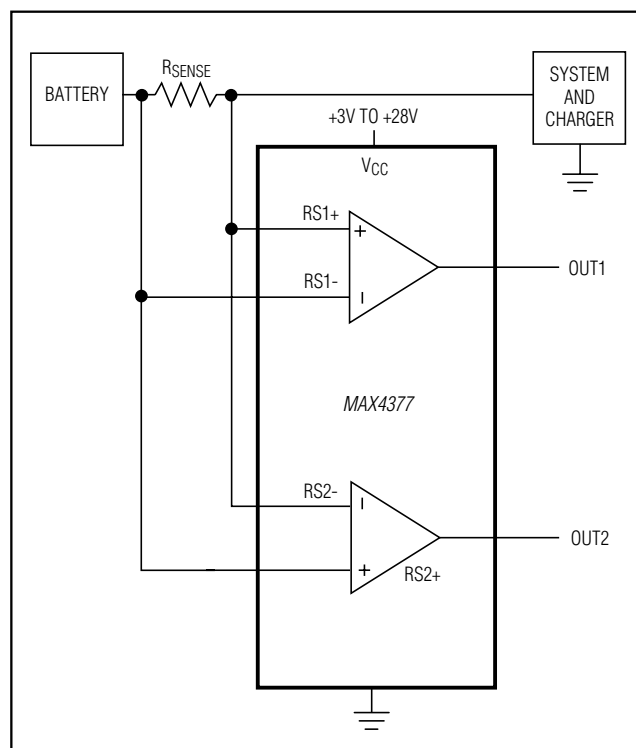

Figure 2. Bidirectional Current Monitor

MAX4376/MAX4377/MAX4378

Single/Dual/Quad, High-Side Current-Sense Amplifiers with Internal Gain

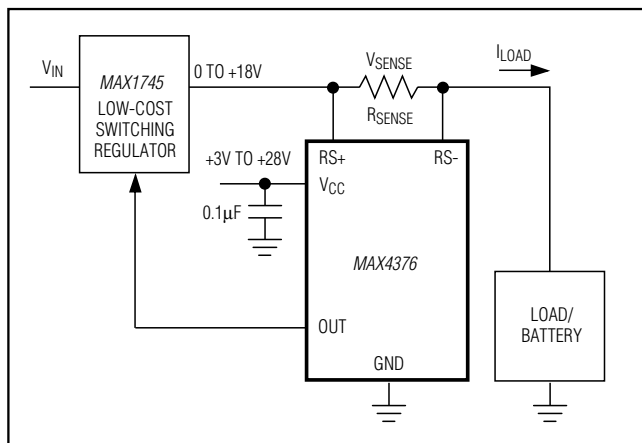
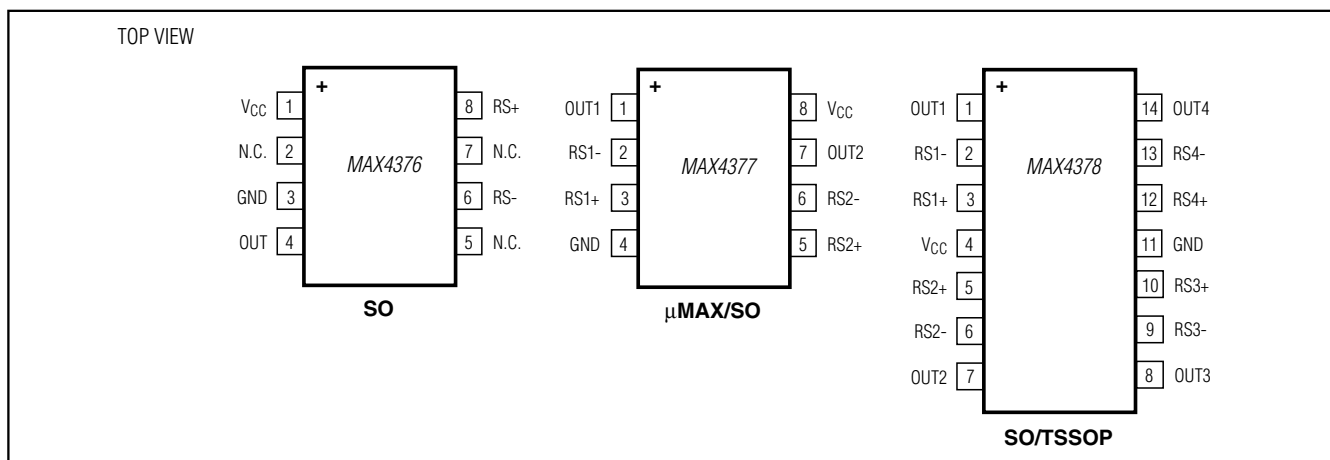

Figure 3. Current Source

Chip Information

PROCESS: BICMOS

Pin Configurations (continued)



Ordering Information (continued)

PART	GAIN (+V/V)	TEMP RANGE	PIN-PACKAGE	TOP MARK
MAX4377TAUA+	20	-40°C to +125°C	8 µMAX	—
MAX4377FAUA+	50	-40°C to +125°C	8 µMAX	—
MAX4377HAUA+	100	-40°C to +125°C	8 µMAX	—
MAX4377TASA+	20	-40°C to +125°C	8 SO	—
MAX4377FASA+	50	-40°C to +125°C	8 SO	—
MAX4377HASA+	100	-40°C to +125°C	8 SO	—
MAX4378TAUD+	20	-40°C to +125°C	14 TSSOP	—
MAX4378FAUD+	50	-40°C to +125°C	14 TSSOP	—
MAX4378HAUD+	100	-40°C to +125°C	14 TSSOP	—
MAX4378TASD+	20	-40°C to +125°C	14 SO	—
MAX4378FASD+	50	-40°C to +125°C	14 SO	—
MAX4378HASD+	100	-40°C to +125°C	14 SO	—

+Denotes a lead(Pb)-free/RoHS-compliant package.

Typical Operating Circuit

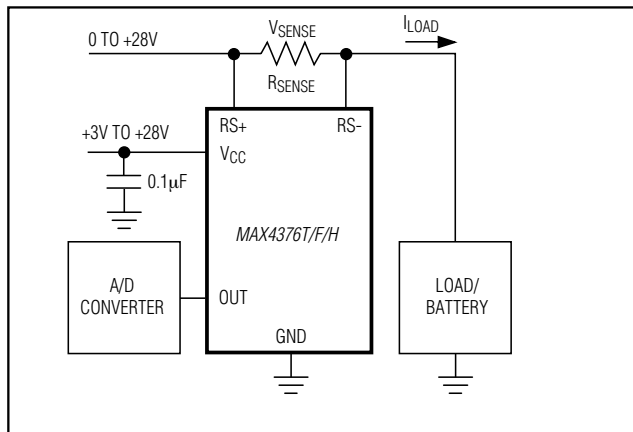

MAX4376/MAX4377/MAX4378

Single/Dual/Quad, High-Side Current-Sense Amplifiers with Internal Gain

Package Information

For the latest package outline information and land patterns (footprints), go to www.maximintegrated.com/packages. Note that a "+", "#", or "-" in the package code indicates RoHS status only. Package drawings may show a different suffix character, but the drawing pertains to the package regardless of RoHS status.

PACKAGE TYPE	PACKAGE CODE	OUTLINE NO.	LAND PATTERN NO.
5 SOT	U5+1	21-0057	90-0174
8 SOIC	S8+2	21-0041	90-0096
8 μ MAX	U8+1	21-0036	90-0092
14 SOIC	S14+1	21-0041	90-0096
14 TSSOP	U14+1	21-0066	90-0117

MAX4376/MAX4377/MAX4378

Single/Dual/Quad, High-Side Current-Sense Amplifiers with Internal Gain

Revision History

REVISION NUMBER	REVISION DATE	DESCRIPTION	PAGES CHANGED
4	4/09	Added automotive part number and lead-free designations	1, 9
5	6/10	Clarified 0V to 2V is not a high-accuracy range for the device, added soldering temperature and <i>Package Information</i> section	1, 2, 10
6	2/11	Specified V_{RS+} value	2, 3
7	10/12	Added MAX4376HASA+ and MAX4376TAUK/V+T to <i>Ordering Information</i>	1



Maxim Integrated cannot assume responsibility for use of any circuitry other than circuitry entirely embodied in a Maxim Integrated product. No circuit patent licenses are implied. Maxim Integrated reserves the right to change the circuitry and specifications without notice at any time. The parametric values (min and max limits) shown in the Electrical Characteristics table are guaranteed. Other parametric values quoted in this data sheet are provided for guidance.

Maxim Integrated 160 Rio Robles, San Jose, CA 95134 USA 1-408-601-1000

11