

RELIABILITY REPORT
FOR
MAX4007EUT
PLASTIC ENCAPSULATED DEVICES

April 28, 2003

MAXIM INTEGRATED PRODUCTS

120 SAN GABRIEL DR.

SUNNYVALE, CA 94086

Written by



Jim Pedicord
Quality Assurance
Reliability Lab Manager

Reviewed by



Bryan J. Preeshl
Quality Assurance
Executive Director

Conclusion

The MAX4007 successfully meets the quality and reliability standards required of all Maxim products. In addition, Maxim's continuous reliability monitoring program ensures that all outgoing product will continue to meet Maxim's quality and reliability standards.

Table of Contents

I.Device Description	V.Quality Assurance Information
II.Manufacturing Information	VI.Reliability Evaluation
III.Packaging Information	IV.Die Information
Attachments

I. Device Description

A. General

The MAX4007 precision, high-side, current monitor is specifically designed for monitoring photodiode current in fiber applications. It offers a connection point for the reference current and a monitor output that produces a signal proportional to the reference current. The monitor output of the MAX4007 is a current proportional to the reference current. The current monitor has six decades of dynamic range and monitor reference current of 250nA to 2.5mA with better than 5% accuracy. The photodiode current can be monitored from 10nA to 10mA with reduced accuracy.

The MAX4007 accepts a supply voltage of +2.7V to +76V, suitable for APD or PIN photodiode applications. Internal current limiting (20mA, typ) protects the device against short circuit to ground. A clamp diode protects the monitor output from overvoltage. Additionally, these devices feature thermal shutdown if the die temperature reaches +150°C.

The MAX4007 is available in tiny, space-saving 6-pin SOT23 packages, and operates over the extended temperature range of -40°C to +85°C.

B. Absolute Maximum Ratings

<u>Item</u>	<u>Rating</u>
CLAMP to GND	-0.3V to +80V
BIAS, REF to GND	-0.3V to +80V
OUT to GND	-0.3V to (VCLAMP + 0.6V)
Short-Circuit, REF to GND	Continuous
Current into any Pin	±30mA
Operating Temperature Range	-40°C to +85°C
Junction Temperature	+150°C
Storage Temperature Range	-65°C to +150°C
Lead Temperature (soldering, 10s)	+300°C
Continuous Power Dissipation (TA = +70C)	
6-PIN SOT23	696mW
Derates above +70°C	
6-PIN SOT23	8.7mW/°C

II. Manufacturing Information

A. Description/Function:	High-Accuracy, 76V, High-Side=Current Monitors in SOT23
B. Process:	BCD80
C. Number of Device Transistors:	195
D. Fabrication Location:	Oregon, USA
E. Assembly Location:	Thailand, Malaysia, USA
F. Date of Initial Production:	January, 2003

III. Packaging Information

A. Package Type:	6-Pin SOT
B. Lead Frame:	Copper
C. Lead Finish:	Solder Plate
D. Die Attach:	Non-Conductive Epoxy
E. Bondwire:	Gold (1 mil dia.)
F. Mold Material:	Epoxy with silica filler
G. Assembly Diagram:	# 05-9000-0357
H. Flammability Rating:	Class UL94-V0
I. Classification of Moisture Sensitivity per JEDEC standard JESD22-112:	Level 1

IV. Die Information

A. Dimensions:	60 X 41 mils
B. Passivation:	Si ₃ N ₄ /SiO ₂ (Silicon nitride/ Silicon dioxide)
C. Interconnect:	Aluminum/Si (Si = 1%)
D. Backside Metallization:	None
E. Minimum Metal Width:	3 microns (as drawn)
F. Minimum Metal Spacing:	3 microns (as drawn)
G. Bondpad Dimensions:	5 mil. Sq.
H. Isolation Dielectric:	SiO ₂
I. Die Separation Method:	Wafer Saw

V. Quality Assurance Information

- A. Quality Assurance Contacts: Jim Pedicord (Reliability Lab Manager)
Bryan Preeshl (Executive Director)
Kenneth Huening (Vice President)
- B. Outgoing Inspection Level: 0.1% for all electrical parameters guaranteed by the Datasheet.
0.1% For all Visual Defects.
- C. Observed Outgoing Defect Rate: < 50 ppm
- D. Sampling Plan: Mil-Std-105D

VI. Reliability Evaluation

A. Accelerated Life Test

The results of the 135°C biased (static) life test are shown in **Table 1**. Using these results, the Failure Rate (λ) is calculated as follows:

$$\lambda = \frac{1}{\text{MTTF}} = \frac{1.83}{192 \times 4389 \times 48 \times 2} \quad (\text{Chi square value for MTTF upper limit})$$

▲
Temperature Acceleration factor assuming an activation energy of 0.8eV

$$\lambda = 22.62 \times 10^{-9}$$

$$\lambda = 22.62 \text{ F.I.T. (60\% confidence level @ 25°C)}$$

This low failure rate represents data collected from Maxim's reliability monitor program. In addition to routine production Burn-In, Maxim pulls a sample from every fabrication process three times per week and subjects it to an extended Burn-In prior to shipment to ensure its reliability. The reliability control level for each lot to be shipped as standard product is 59 F.I.T. at a 60% confidence level, which equates to 3 failures in an 80 piece sample. Maxim performs failure analysis on any lot that exceeds this reliability control level. Attached Burn-In Schematic (Spec. # 06-6107) shows the static Burn-In circuit. Maxim also performs quarterly 1000 hour life test monitors. This data is published in the Product Reliability Report (**RR-1M**).

B. Moisture Resistance Tests

Maxim pulls pressure pot samples from every assembly process three times per week. Each lot sample must meet an LTPD = 20 or less before shipment as standard product. Additionally, the industry standard 85°C/85%RH testing is done per generic device/package family once a quarter.

C. E.S.D. and Latch-Up Testing

The OY13 die type has been found to have all pins able to withstand a transient pulse of $\pm 2500\text{V}$, per Mil-Std-883 Method 3015 (reference attached ESD Test Circuit). Latch-Up testing has shown that this device withstands a current of $\pm 250\text{mA}$.

Table 1
Reliability Evaluation Test Results

MAX4007EUT

TEST ITEM	TEST CONDITION	FAILURE IDENTIFICATION	PACKAGE	SAMPLE SIZE	NUMBER OF FAILURES
Static Life Test (Note 1)					
	Ta = 135°C Biased Time = 192 hrs.	DC Parameters & functionality		45	0
Moisture Testing (Note 2)					
Pressure Pot	Ta = 121°C P = 15 psi. RH= 100% Time = 168hrs.	DC Parameters & functionality	SOT	77	0
85/85	Ta = 85°C RH = 85% Biased Time = 1000hrs.	DC Parameters & functionality		77	0
Mechanical Stress (Note 2)					
Temperature Cycle	-65°C/150°C 1000 Cycles Method 1010	DC Parameters & functionality		77	0

Note 1: Life Test Data may represent plastic DIP qualification lots.

Note 2: Generic Package/Process data

Attachment #1

TABLE II. Pin combination to be tested. 1/ 2/

	Terminal A (Each pin individually connected to terminal A with the other floating)	Terminal B (The common combination of all like-named pins connected to terminal B)
1.	All pins except V_{PS1} <u>3/</u>	All V_{PS1} pins
2.	All input and output pins	All other input-output pins

1/ Table II is restated in narrative form in 3.4 below.

2/ No connects are not to be tested.

3/ Repeat pin combination 1 for each named Power supply and for ground

(e.g., where V_{PS1} is V_{DD} , V_{CC} , V_{SS} , V_{BB} , GND, $+V_S$, $-V_S$, V_{REF} , etc).

3.4 Pin combinations to be tested.

- a. Each pin individually connected to terminal A with respect to the device ground pin(s) connected to terminal B. All pins except the one being tested and the ground pin(s) shall be open.
- b. Each pin individually connected to terminal A with respect to each different set of a combination of all named power supply pins (e.g., V_{SS1} , or V_{SS2} or V_{SS3} or V_{CC1} , or V_{CC2}) connected to terminal B. All pins except the one being tested and the power supply pin or set of pins shall be open.
- c. Each input and each output individually connected to terminal A with respect to a combination of all the other input and output pins connected to terminal B. All pins except the input or output pin being tested and the combination of all the other input and output pins shall be open.

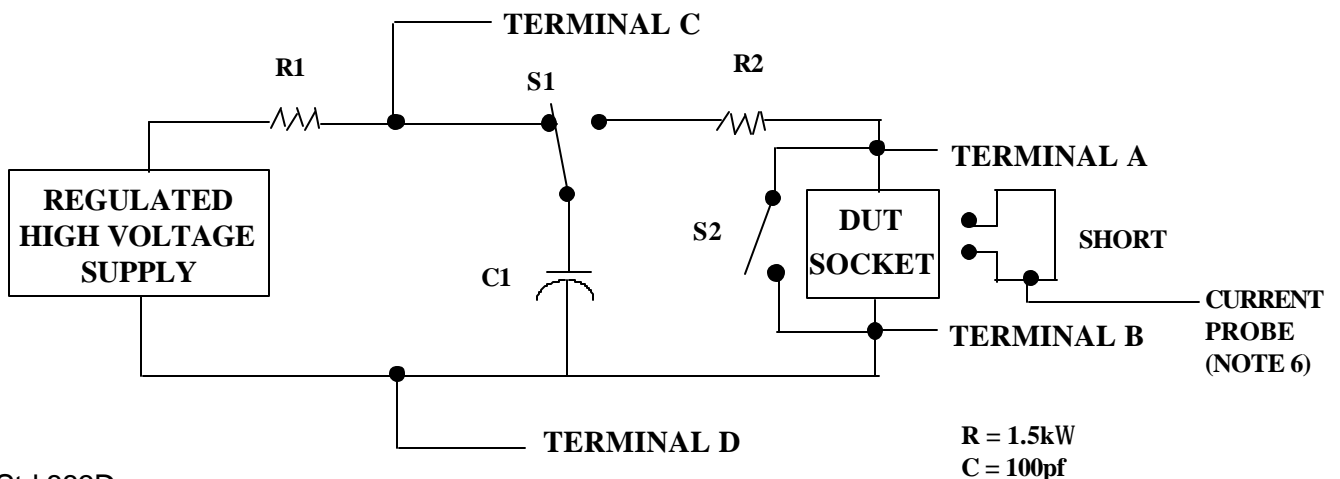

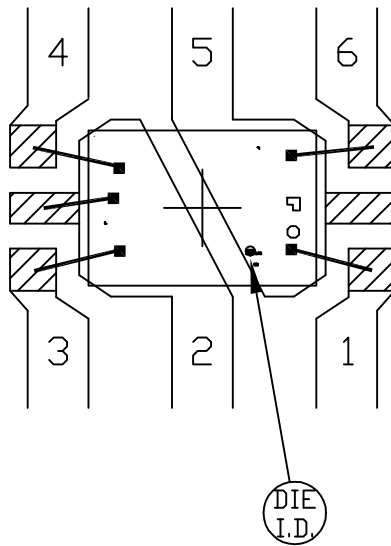

NOTE: USE NON-CONDUCTIVE EPOXY ONLY

CAVITY DOWN

 BONDABLE AREA

PKG. CODE: U6S-3		SIGNATURES	DATE	 CONFIDENTIAL & PROPRIETARY	
CAV./PAD SIZE: 64x46	PKG. DESIGN			BOND DIAGRAM #: 05-9000-0357	REV: A

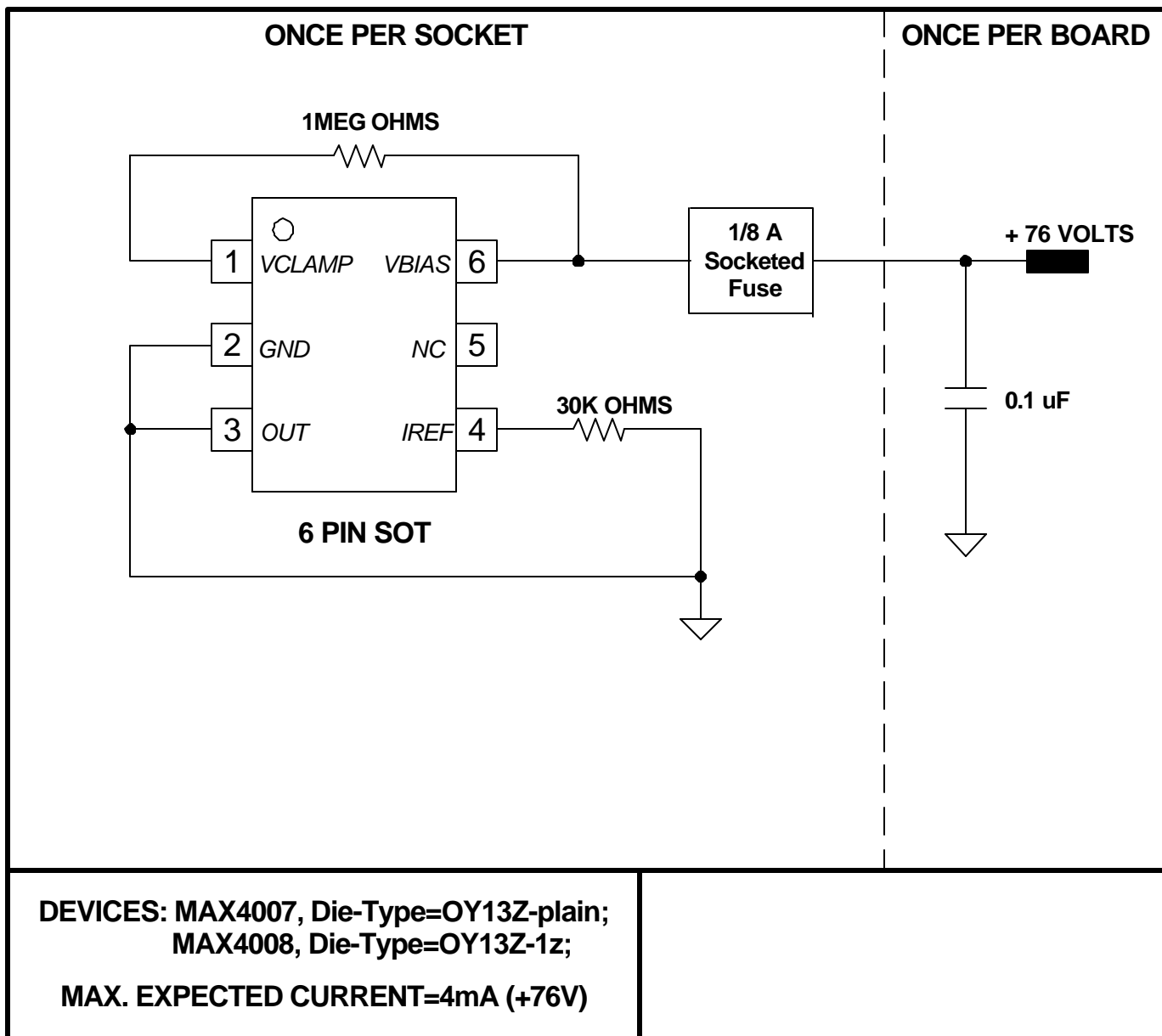

- Note: a) Burn-in performance for MAX4004 is qualified by extension from MAX4007 as they use the same die-type OY13Z-plain.
- b) Burn-in performance for MAX4006 is qualified by extension from MAX4008 as they use the same die-type OY13Z-1z.