



Ultra-Low Leakage Monolithic CMOS Analog Multiplexers

MAX328/MAX329

General Description

The MAX328/MAX329 are monolithic CMOS analog multiplexers. The MAX328 is a single-ended, 1-of-8 device, and the MAX329 is a differential, 2-of-8 device.

Designed to provide the lowest possible "on" and "off" leakages, these multiplexers switch signals from high source impedance, providing the mux operates into a high input impedance op amp or A/D converter. The MAX328/MAX329 are pin-for-pin replacements for the popular DG508/DG509 in these applications.

Adding an external 40kΩ resistor to each input makes the MAX328/MAX329 an excellent fault-tolerant multiplexer. Low leakage (less than 1pA at 25°C) and 2.5kΩ on resistance allow the circuit to sustain 110V AC faults indefinitely while maintaining an error of less than 40nV for normal signals (i.e., 1pA times 40kΩ).

The MAX328/MAX329 work equally well with a single supply of 10V to 30V or dual supplies of ±5V to ±18V. They also perform well with unbalanced combinations of supply voltage, such as +12V and -5V or +5V and -15V. Low-power dissipation (1.9mW with ±15V supplies) allows use of the multiplexers in portable applications.

Applications

- Control Systems
- Data Logging Systems
- Aircraft Heads-Up Displays
- Data Acquisition Systems
- Signal Routing

Typical Operating Circuit

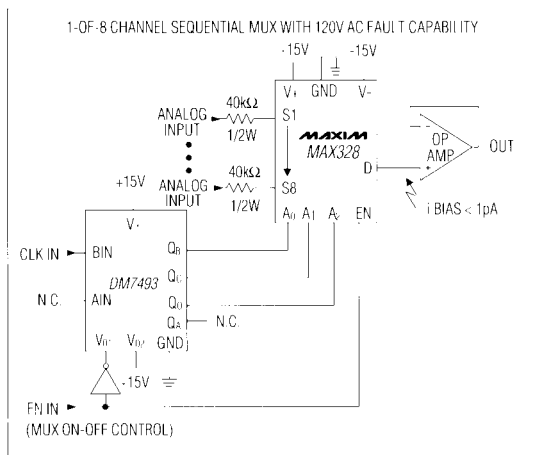

Features

- ◆ Ultra-Low "Off" and "On" Leakage: 1pA Typ
- ◆ Bi-Directional Operation (Use as Mux or Demux)
- ◆ TTL and CMOS Logic Compatibility
- ◆ Analog-Signal Range Includes Power-Supply Rails
- ◆ Switching Speeds Less Than 1.5μs
- ◆ Pin Compatible With DG508/DG509 and MAX358/MAX359
- ◆ Latch-Up Proof Construction

Ordering Information

PART	TEMP. RANGE	PIN-PACKAGE
MAX328CPE	0°C to +70°C	16 Plastic DIP
MAX328CWE	0°C to +70°C	16 Wide SO
MAX328CJE	0°C to +70°C	16 CERDIP
MAX328C/D	0°C to +70°C	Dice*
MAX328EPE	-40°C to +85°C	16 Plastic DIP
MAX328EWE	-40°C to +85°C	16 Wide SO
MAX328EJE	-40°C to +85°C	16 CERDIP**
MAX328MJE	-55°C to +125°C	16 CERDIP**

Ordering information continued at end of data sheet.
 * Contact factory for dice specifications.
 ** Contact factory for availability. Substrate may be allowed to float or be tied to V+.

Pin Configurations

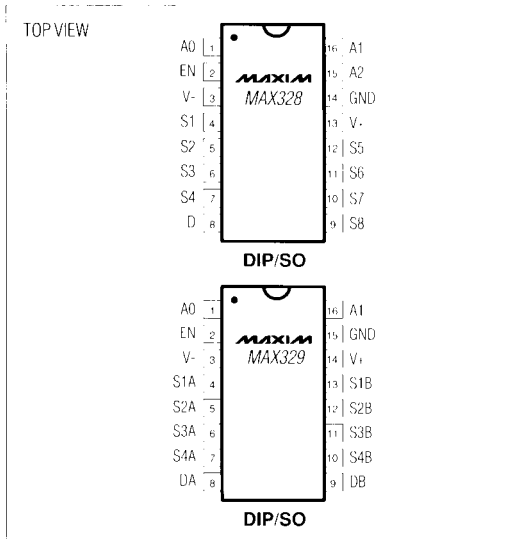

Call toll free 1-800-998-8800 for free samples or literature.

Ultra-Low Leakage Monolithic CMOS Analog Multiplexers

ABSOLUTE MAXIMUM RATINGS

Voltage Referenced to V-		Operating Temperature Range:
V+	+44V	MAX328/329 C 0 C to +70 C
GND	+25V	MAX328/329 E -40 C to +85 C
Digital Inputs (Note 1), V _S , V _D	-2V to (V+ + 2V)	MAX328/329 M -55 C to +125 C
Current (Any Terminal, Except S or D)	30mA	Power Dissipation (Package) (Note 1)
Continuous Current, S or D	10mA	16-Pin CERDIP (Note 2) 900mW
Peak Current, S or D		16-Pin Plastic DIP (Note 3) 470mW
(Pulsed at 1ms, 10% Duty Cycle Max)	40mA	16-Pin Wide SO (Note 4) 750mW
		Storage Temperature -65 C to +150 C

Stresses listed under "Absolute Maximum Ratings" may be applied (one at a time) to devices without resulting in permanent damage. These are stress ratings only, and functional operation of the device at these or any other conditions beyond those indicated in the operational sections of the specifications is not implied. Exposure to absolute maximum rating conditions for extended periods may affect device reliability.

ELECTRICAL CHARACTERISTICS

(V+ = +15V, V- = -15V, GND = 0V, T_A = +25°C, unless otherwise noted.)

PARAMETER	SYMBOL	TEST CONDITIONS	LIMITS						UNITS
			MAX328M MAX329M			MAX328C/E MAX329C/E			
			MIN	TYP	MAX	MIN	TYP	MAX	
SWITCH									
Analog Signal Range	V _{ANALOG}		±15			±15			V
Drain-Source On Resistance	r _{DS(on)}	V _D = 10V, I _S = 100µA	Seq. Each Switch On		1.5	2.5	1.5	3.5	kΩ
		V _D = -10V, I _S = 100µA	V _{AL} = 0.8V V _{AH} = 2.4V		1.0	2.5	1.0	3.5	
Greatest Change in Drain-Source On-Resistance Between Channels	Δr _{DS(on)}	r _{DS(on)} = $\left(\frac{r_{DS(on) \text{ Max}} - r_{DS(on) \text{ Min}}}{r_{DS(on) \text{ Ave}}} \right)$	2			2			%
Source-Off Leakage Current (Note 5)	I _{S(off)}	V _S = 10V, V _D = -10V	V _{EN} = 0V		0.1	±10	0.1	±10	pA
		V _S = -10V, V _D = 10V			0.3	±10	0.3	±10	
Drain-Off Leakage Current (Note 5)	MAX328	V _D = 10V, V _S = -10V	V _{EN} = 0V		0.3	±10	0.3	±10	pA
	MAX329	V _D = -10V, V _S = 10V			1.0	±10	1.0	±10	
		V _D = 10V, V _S = -10V			0.3	±10	0.3	±10	
		V _D = -10V, V _S = 10V			0.5	±10	0.5	±10	
Drain-On Leakage Current (Note 5)	MAX328	V _S (all) = V _D = 10V	Seq. Each Switch On		3.0	±10	3.0	±10	pA
	MAX329	V _S (all) = V _D = -10V	V _{AL} = 0.8V		2.0	±10	2.0	±10	
		V _S (all) = V _D = 10V	V _{AH} = 2.4V		1.5	±10	1.5	±10	
		V _S (all) = V _D = -10V			1.0	±10	1.0	±10	

Ultra-Low Leakage Monolithic CMOS Analog Multiplexers

MAX328/MAX329

ELECTRICAL CHARACTERISTICS (continued)

(V+ = +15V, V- = -15V, GND = 0V, TA = +25°C, unless otherwise noted.)

PARAMETER	SYMBOL	TEST CONDITIONS	LIMITS						UNITS
			MAX328M MAX329M			MAX328C/E MAX329C/E			
			MIN	TYP	MAX	MIN	TYP	MAX	
INPUT									
Address Input Current, Input Voltage High	IAH	VA = 2.4V	.001	±1		.001	+1	μA	
		VA = 15V	.001	±1		.001	±1		
Address Input Current, Input Voltage Low	IAL	VEN = 2.4V	.001	±1		.001	+1	μA	
		VFN = 0V	.001	±1		.001	±1		
DYNAMIC									
Switching Time Of Multiplexer	ttransition	See Figure 1			1.0		1.5	μs	
Break-Before-Make Interval	topen	See Figure 2		0.2		0.2		μs	
Enable Turn-On Time	ton(EN)	See Figure 3			1.0		1.5	μs	
Enable Time-Off Time	toff(EN)	See Figure 3			0.7		1.0	μs	
OFF Isolation	OIRR	VEN = 0V, RL = 1kΩ, CL = 15pF VS = 7VRMS, f = 500kHz		84		84		dB	
Source-Off Capacitance	CS(off)	VS = 0V		1.8		1.8		pF	
Drain-Off Capacitance	MAX328	VD = 0V	VEN = 0V, f = 1MHz	8.0		8.0		pF	
	MAX329			4.0		4.0			
Charge Injection (Note 7)	Q(irj)	VA = +10V		1		1		pC	
		VA = 0V		2	5		2		5
		VA = -10V		4		4			
SUPPLY									
Positive Supply Current	I+	VEN = 2.4V	VA = 0V/5V	4.5	200	4.5	200	μA	
Negative Supply Current	I-	VFN = 2.4V	VA = 0V/5V	1	-100	1	-100		
Power-Supply Range For Continuous Operation (Note 6)	VOP			±5	±18	±5	±18	V	

Note 1: All leads soldered or welded to PC board.

Note 2: Derate 12mW/°C above +75°C.

Note 3: Derate 6.3mW/°C above +75°C.

Note 4: Derate 10mW/°C above +75°C.

Note 5: All leakage parameters are 100% tested at maximum rated operating temperature, i.e., +70°C, +85°C, +125°C, and guaranteed by correlation at +25°C.

Note 6: Electrical characteristics, such as On Resistance, will change when power supplies other than ±15V are used. Power-supply range is a design characteristic, not production tested.

Note 7: Guaranteed by design.

Typical values are for DESIGN AID ONLY, not guaranteed or subject to production testing.

Ultra-Low Leakage Monolithic CMOS Analog Multiplexers

ELECTRICAL CHARACTERISTICS (Over Temperature)

(V+ = +15V, V- = -15V, GND = 0V, TA = TMIN to TMAX, unless otherwise noted.)

PARAMETER	SYMBOL	TEST CONDITIONS	LIMITS						UNITS		
			MAX328M MAX329M			MAX328C/E MAX329C/E					
			MIN	TYP	MAX	MIN	TYP	MAX			
SWITCH											
Analog-Signal Range	VANALOG		±15			±15			V		
Drain-Source On Resistance	r _{DS(on)}	V _D = 10V, I _S = 100μA	Seq. Each Switch On V _{AL} = 0.8V, V _{AH} = 2.4V			2.2	4	1.9	5	kΩ	
		V _D = -10V, I _S = 100μA				1.5	4	1.2	5		
Source-Off Leakage Current (Note 8)	I _{S(off)}	V _S = 10V, V _D = -10V	V _{FN} = 0V				±5			nA	
		V _S = -10V, V _D = 10V					±5				
Drain-Off Leakage Current (Note 8)	MAX328	I _{D(off)}	V _{EN} = 0V	V _D = 10V, V _S = -10V			±20			nA	
				V _D = -10V, V _S = 10V			±20				
	MAX329	V _D = 10V, V _S = -10V			±10			nA			
		V _D = -10V, V _S = 10V			±10						
Drain-On Leakage Current (Note 8)	MAX328	I _{D(on)}	Seq. Each Switch On V _{AL} = 0.8V, V _{AH} = 2.4V	V _{S(all)} = V _D = 10V			±20			nA	
				V _{S(all)} = V _D = -10V			±20				
	MAX329			V _{S(all)} = V _D = 10V			±10				
				V _{S(all)} = V _D = -10V			±10				
INPUT											
Address Input Current, Input Voltage High	I _{AH}	V _A = 2.4V				.01	±1	.01	+1	μA	
		V _A = 15V				.01	±1	.01	±1		
Address Input Current, Input Voltage Low	I _{AL}	V _{EN} = 2.4V	All V _A = 0V				.01	±1	.01	+1	μA
		V _{EN} = 0V					.01	±1	.01	±1	

Note 8: Leakage parameters are 100% tested at maximum rated operating temperature, i.e., +70°C, etc.

Ultra-Low Leakage Monolithic CMOS Analog Multiplexers

MAX328/MAX329

TRUTH TABLE - MAX328

A ₂	A ₁	A ₀	EN	ON SWITCH
X	X	X	0	NONE
0	0	0	1	1
0	0	1	1	2
0	1	0	1	3
0	1	1	1	4
1	0	0	1	5
1	0	1	1	6
1	1	0	1	7
1	1	1	1	8

TRUTH TABLE - MAX329

A ₁	A ₀	EN	ON SWITCH
X	X	0	NONE
0	0	1	1
0	1	1	2
1	0	1	3
1	1	1	4

Note: Logic '0' = V_{A1} ≤ 0.8V. Logic '1' = V_{A1} > 2.4V

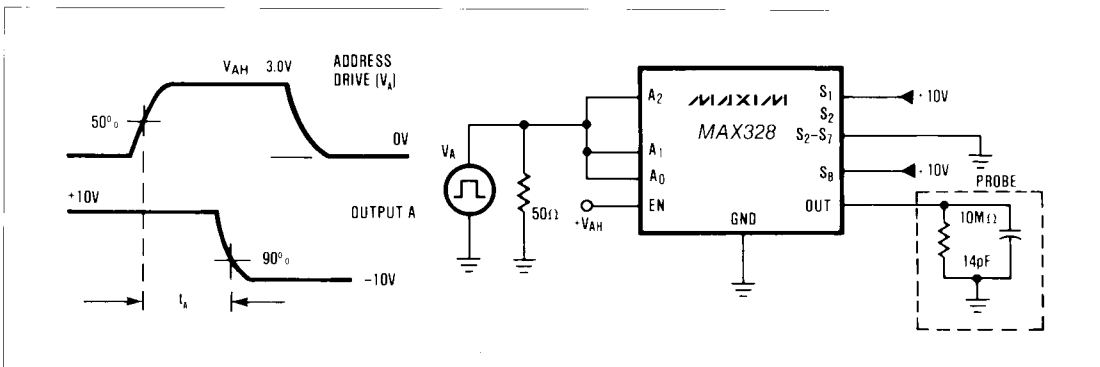

Figure 1. Access Time vs. Logic Level (High)

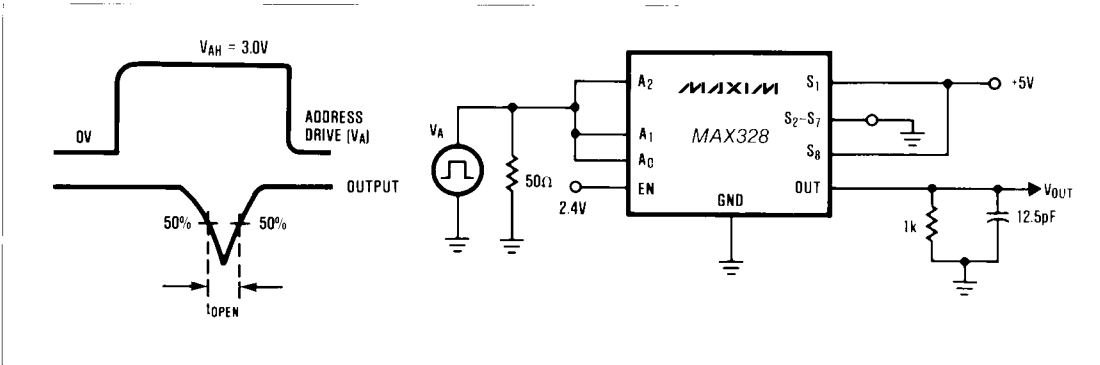

Figure 2. Break-Before-Make Delay (t_{OPEN})

Ultra-Low Leakage Monolithic CMOS Analog Multiplexers

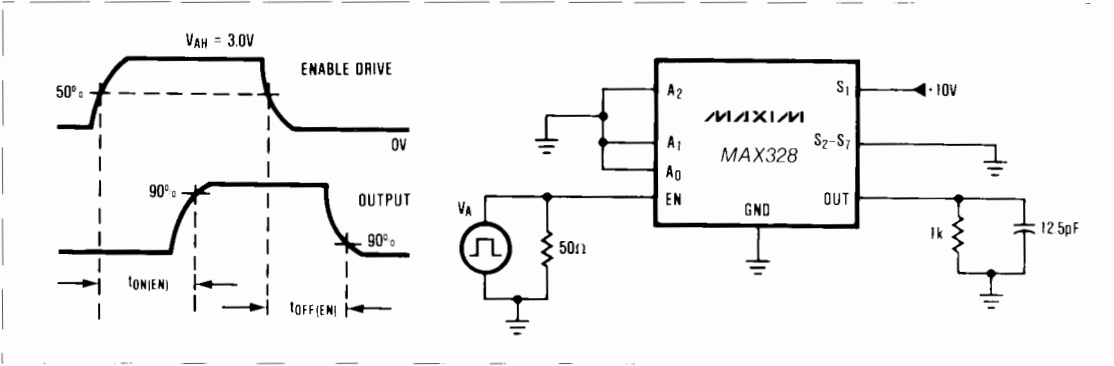
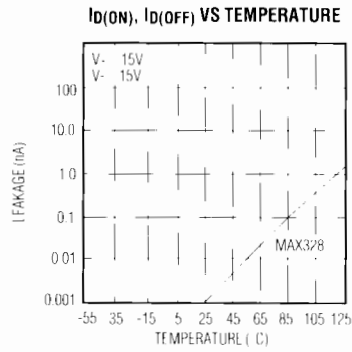
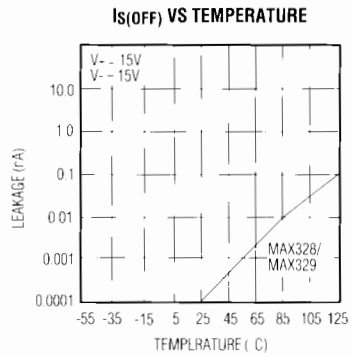
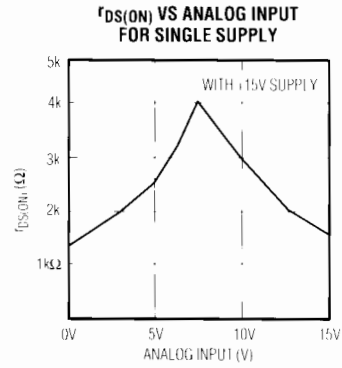
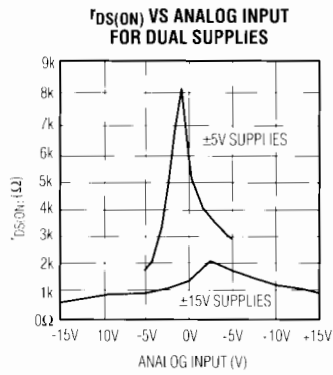

Figure 3. Enable Delay ($t_{ON(EN)}$, $t_{OFF(EN)}$)

Typical Operating Characteristics



Ultra-Low Leakage Monolithic CMOS Analog Multiplexers

Application Notes

Figure 4 is a typical circuit for converting the MAX328/MAX329 into a fault-tolerant mux. In this application, the internal diodes limit the voltage at the MAX328 input to $\pm 15.7V$ ($\pm 15V$ supplies). No external diodes need to be added with the MAX328/MAX329, unlike conventional multiplexers requiring external diodes.

The resistors, R, need to be $39k\Omega$ or higher to limit the power dissipation in the resistor when a 120V AC fault occurs (i.e., power dissipation is $(120-16)^2/39k\Omega$ or $0.28W$. This is why a $1/2W$ resistor is needed). The circuit withstands an indefinite fault to a 120V AC line with no damage to any component.

In addition to allowing fault-protection, the guaranteed low leakage of the MAX328/MAX329 also reduces signal errors. The circuit in Figure 4 produces an error voltage of $10pA$ (max leakage) $\times 39k\Omega$ or $0.39\mu V$ at room temperature and $39\mu V$ at $+125^\circ C$. Therefore, for 10V signals, the MAX328/MAX329 allows 17-bit resolution ($38\mu V = 1LSB$) over the full temperature range.

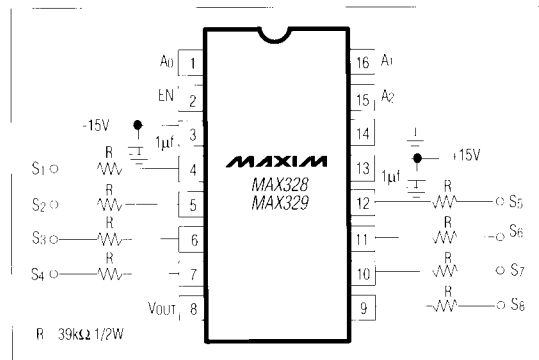
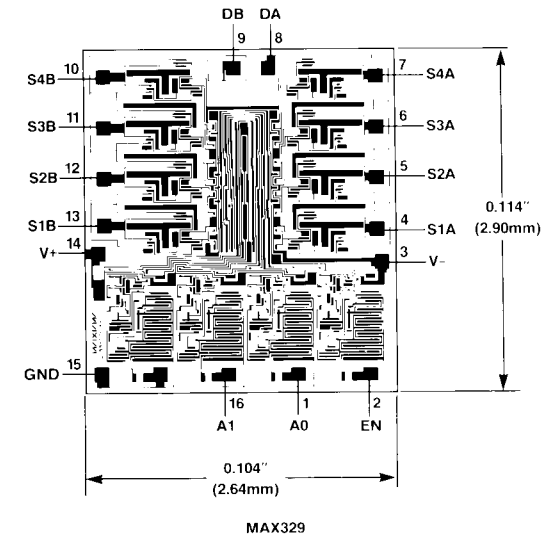
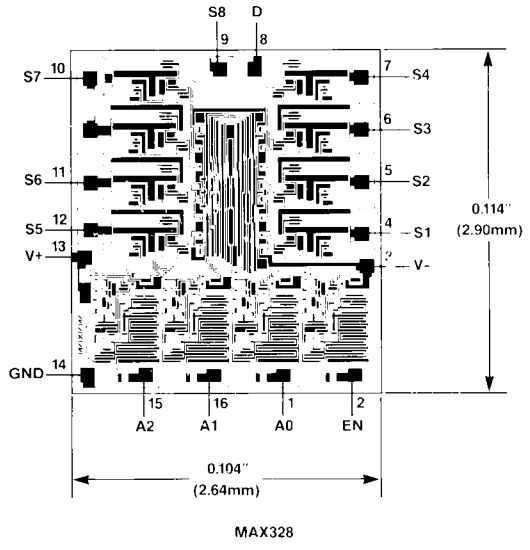

Figure 4. Fault-tolerant MUX (indefinitely withstands 120V AC fault voltages)

Chip Topographies

MAX328/MAX329



Ultra-Low Leakage Monolithic CMOS Analog Multiplexers

_ Ordering Information (continued)

PART	TEMP. RANGE	PIN-PACKAGE
MAX329CPE	0°C to +70°C	16 Plastic DIP
MAX329CWE	0°C to +70°C	16 Wide SO
MAX329CJE	0°C to +70°C	16 CERDIP
MAX329C/D	0°C to +70°C	Dice*
MAX329EPE	-40°C to +85°C	16 Plastic DIP
MAX329EWE	-40°C to +85°C	16 Wide SO
MAX329EJE	-40°C to +85°C	16 CERDIP**
MAX329MJE	-40°C to +85°C	16 CERDIP**

* Contact factory for dice specifications.

** Contact factory for availability. Substrate may be allowed to float or be tied to V+.

Maxim cannot assume responsibility for use of any circuitry other than circuitry entirely embodied in a Maxim product. No circuit patent licenses are implied. Maxim reserves the right to change the circuitry and specifications without notice at any time.

8 _____ **Maxim Integrated Products, 120 San Gabriel Drive, Sunnyvale, CA 94086 (408) 737-7600**

© 1994 Maxim Integrated Products

Printed USA

MAXIM is a registered trademark of Maxim Integrated Products.