



Low-Power AppleTalk Interface Transceiver

MAX216

General Description

The MAX216 transceiver is designed specifically for communicating with AppleTalk™ interfaces. The MAX216 has one differential and one single-ended driver, plus one differential and two single-ended receivers, all of which meet the AppleTalk transceiver specifications.

The single-ended and differential drivers have a $\pm 5V$ output voltage range when they are active, and have thermal shutdown protection against short circuits. The drivers remain in a high-impedance state when disabled or shut down.

One single-ended receiver is configured as an inverter, and the other is configured as a buffer. The input thresholds of the single-ended receivers are TTL-compatible, but the input voltages can vary between $\pm 7V$. The input thresholds of the differential receiver are $\pm 200mV$, and have a common-mode range of $\pm 7V$.

The MAX216 uses only 3mA max when fully operational. The drivers and receivers are disabled during shutdown mode, when the quiescent current is reduced to only 30 μA .

Applications

- AppleTalk Interfaces
- Apple Printer Interfaces
- Apple Peripheral Interface
- EIA/TIA-232/562 to RS-422 Conversion

Typical Operating Circuit

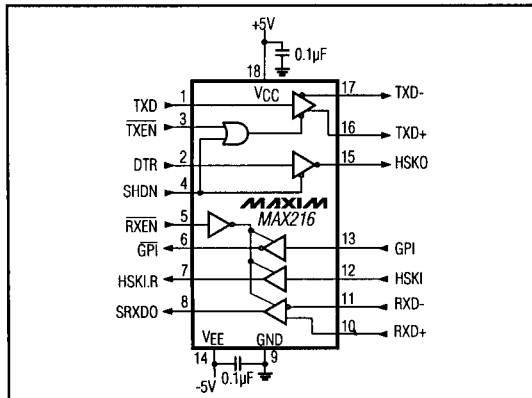

™AppleTalk is a trademark of Apple Computer, Inc.

Features

- ◆ Differential Driver/Receiver Compatible with RS-422
- ◆ Single-Ended Driver/Receiver Compatible with EIA/TIA-562 and EIA/TIA-232E
- ◆ Low, 3mA Max Operational Supply Current
- ◆ Low, 30 μA Shutdown-Mode Supply Current

Ordering Information

PART	TEMP. RANGE	PIN-PACKAGE
MAX216CWN	0°C to +70°C	18 Wide SO

Pin Configuration

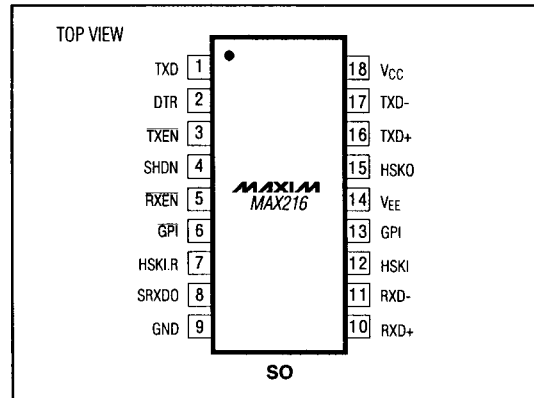

Low-Power AppleTalk Interface Transceiver

MAX216

ABSOLUTE MAXIMUM RATINGS

V _{CC}	+7V	Short-Circuit Duration	
V _{EE}	-7V	Driver Outputs (to V _{CC} or V _{EE}).....	Continuous
Input Voltages		Receiver Outputs (to V _{CC} or GND).....	Continuous
Driver Inputs.....	-0.5V to (V _{CC} + 0.5V)	Continuous Power Dissipation (T _A = +70°C)	
Receiver Inputs.....	±15V	SO (derate 9.52mW/°C above +70°C).....	762mW
Control Input Voltages.....	-0.5V to (V _{CC} + 0.5V)	Operating Temperature Range.....	0°C to +70°C
Output Voltages		Storage Temperature Range.....	-65°C to +160°C
Driver Outputs.....	±15V	Lead Temperature (soldering, 10sec).....	+300°C
Receiver Outputs.....	-0.5V to (V _{CC} + 0.5V)		

Stresses beyond those listed under "Absolute Maximum Ratings" may cause permanent damage to the device. These are stress ratings only, and functional operation of the device at these or any other conditions beyond those indicated in the operational sections of the specifications is not implied. Exposure to absolute maximum rating conditions for extended periods may affect device reliability.

ELECTRICAL CHARACTERISTICS – DC PARAMETERS

(V_{CC} = 5V ±5%, V_{EE} = -5V ±5%, T_A = T_{MIN} to T_{MAX}, unless otherwise noted. See Figures 1 and 5.)

PARAMETER	SYMBOL	CONDITIONS	MIN	TYP	MAX	UNITS
POWER SUPPLY						
Positive Supply Current	I _{CC}	No load, SHDN = 0V		1.2	3	mA
		No load, SHDN = V _{CC}		30	100	μA
Negative Supply Current	I _{EE}	No load			100	μA
DIFFERENTIAL DRIVER						
TTL/CMOS Input Levels	V _{IL}	TXD, TXEN, SHDN			0.8	V
	V _{IH}		2.0			
Input Current		TXD, TXEN, SHDN			±20	μA
Differential Driver Output Voltage	V _{OD1}	No load, I _O = 0A, V _{D1}	8.0			V
	V _{OD2}	R = 50Ω, V _{D2}	2.0			
Change in Magnitude of Differential Output Voltage	ΔV _{OD2}	R = 50Ω, V _{D2}			0.2	V
Common-Mode Output Voltage	V _{OC}	R = 50Ω, V _{D2}			3	V
Change in Magnitude of Common-Mode Output Voltage	Δ V _{OC}	R = 50Ω, V _{D2}			0.2	V
Output Common-Mode Range	V _{CMR}	SHDN > 2.0V or power off			±10	V
Short-Circuit Current		-5V ≤ V _O ≤ 5V	35		450	mA
Off-State Output Current		SHDN > 2.0V or power off, -10V < V _O < 10V			±100	μA

Low-Power AppleTalk Interface Transceiver

ELECTRICAL CHARACTERISTICS – DC PARAMETERS (continued)

($V_{CC} = 5V \pm 5\%$, $V_{EE} = -5V \pm 5\%$, $T_A = T_{MIN}$ to T_{MAX} , unless otherwise noted. See Figures 1 and 5.)

PARAMETER	SYMBOL	CONDITIONS	MIN	TYP	MAX	UNITS
SINGLE-ENDED DRIVER						
Input High Voltage	V_{IH}	DTR	2.0			V
Input Low Voltage	V_{IL}	DTR			0.8	V
Input Current		DTR			± 20	μA
Output Voltage	V_{O1}	No load	DTR = 0.8V	4.0		V
			DTR = 2.0V	-4.0		
	V_{O2}	$R_L = 400\Omega$	DTR = 0.8V	3.4		
			DTR = 2.0V	-3.4		
Off-State Output Current		SHDN > 2.0V or power off, -10V < V_O < 10V			± 100	μA
Output Short-Circuit Current		$-5V \leq V_O \leq 5V$	35		450	mA
DIFFERENTIAL RECEIVER						
Receiver Input Current		$V_{IN} = 7V$			1.5	mA
		$V_{IN} = -7V$			-1.5	
Receiver Input Resistance		$-7V \leq V_{IN} \leq 7V$	12			k Ω
Receiver Output High Voltage	V_{OH}	$I_O = -4mA$	3.5			V
Receiver Output Low Voltage	V_{OL}	$I_O = 4mA$			0.4	V
Receiver Short-Circuit Current		$0V \leq V_O \leq 5V$	7.0		85	mA
Disabled Receiver Output Current		$0V \leq V_O \leq 5V$			± 100	μA
Differential Input Threshold Voltage		$-7V \leq V_{CM} \leq 7V$	-0.2		0.2	V
SINGLE-ENDED RECEIVER						
Receiver Input Current		$V_{IN} = 7V$			1.5	mA
		$V_{IN} = -7V$			-1.5	
Receiver Input Resistance		$-7V \leq V_{IN} \leq 7V$	12			k Ω
Receiver Output High Voltage	V_{OH}	$I_O = -4mA$	3.5			V
Receiver Output Low Voltage	V_{OL}	$I_O = 4mA$			0.4	V
Receiver Short-Circuit Current		$0V \leq V_O \leq 5V$	7		85	mA
Disabled Receiver Output Current		$0V \leq V_O \leq 5V$			± 100	μA
Input Low Voltage	V_{IL}				0.8	V
Input High Voltage	V_{IH}		2.0			V

MAX216

Low-Power AppleTalk Interface Transceiver

ELECTRICAL CHARACTERISTICS – AC PARAMETERS

($V_{CC} = 5V \pm 5\%$, $V_{EE} = -5V \pm 5\%$, $T_A = T_{MIN}$ to T_{MAX} , unless otherwise noted. See Figures 2 and 5.)

PARAMETER	SYMBOL	CONDITIONS	MIN	TYP	MAX	UNITS
DIFFERENTIAL DRIVER						
Driver Input to Output	t_{PLH}	$R_L = 100\Omega$, $C_{L1} = 100pF$, $C_{L2} = 100pF$			120	ns
	t_{PHL}				120	
Driver Output to Output	t_{SKEW}	$R_L = 100\Omega$, $C_{L1} = 100pF$, $C_{L2} = 100pF$			30	ns
Driver Rise Time	t_R	$R_L = 100\Omega$, $C_{L1} = 100pF$, $C_{L2} = 100pF$			60	ns
Driver Fall Time	t_F	$R_L = 100\Omega$, $C_{L1} = 100pF$, $C_{L2} = 100pF$			60	ns
Driver Enable to Output High	t_{ZH}	$C_L = 100pF$, Figure 4			150	ns
Driver Enable to Output Low	t_{ZL}	$C_L = 100pF$, Figure 3			150	ns
Driver Disable Time from Low	t_{LZ}	$C_L = 15pF$, Figure 3			150	ns
Driver Disable Time from High	t_{HZ}	$C_L = 15pF$, Figure 4			150	ns
SINGLE-ENDED DRIVER						
Driver Input to Output	t_{PLH}	$R_L = 450\Omega$, $C_L = 100pF$			120	ns
	t_{PHL}				120	
Driver Rise Time	t_R	$R_L = 450\Omega$, $C_L = 100pF$			60	ns
Driver Fall Time	t_F	$R_L = 450\Omega$, $C_L = 100pF$			60	ns
DIFFERENTIAL RECEIVER						
Receiver Input to Output	t_{PLH}	$C_L = 15pF$			160	ns
	t_{PHL}				160	
Receiver Disable Time from Low	t_{LZ}	$C_L = 15pF$, Figure 6			100	ns
Receiver Disable Time from High	t_{HZ}	$C_L = 15pF$, Figure 7			100	ns
Receiver Enable to Output High	t_{ZH}	$C_L = 100pF$, Figure 7			100	ns
Receiver Enable to Output Low	t_{ZL}	$C_L = 100pF$, Figure 6			100	ns
SINGLE-ENDED RECEIVER						
Receiver Input to Output	t_{PLH}	$C_L = 15pF$			160	ns
	t_{PHL}				160	
Receiver Disable Time from Low	t_{LZ}	$C_L = 15pF$, Figure 6			100	ns
Receiver Disable Time from High	t_{HZ}	$C_L = 15pF$, Figure 7			100	ns
Receiver Enable to Output High	t_{ZH}	$C_L = 100pF$, Figure 7			100	ns
Receiver Enable to Output Low	t_{ZL}	$C_L = 100pF$, Figure 6			100	ns

Low-Power AppleTalk Interface Transceiver

Pin Description

MAX216

PIN	NAME	FUNCTION
1	TXD	TTL-compatible differential driver input
2	DTR	TTL-compatible single-ended inverting driver input
3	TXEN	TTL-compatible differential driver output enable. A high input forces the differential driver output into a high-impedance state. A low input enables the differential driver output. This input does not affect the single-ended driver.
4	SHDN	TTL-compatible shutdown input. A high input forces the chip into shutdown, with both driver outputs forced into three-state and the supply current reduced to 20 μ A typ. The receivers are not functional, but their outputs remain enabled unless RXEN is pulled high. A low input forces the chip into normal operation.
5	RXEN	TTL-compatible receiver enable input. A low input enables the outputs of the receivers and a high input forces the receiver outputs into a high-impedance state. To prevent unwanted noise at the output of the receivers in shutdown mode, RXEN should be pulled high along with SHDN.
6	GPI	Inverting single-ended receiver output
7	HSKI.R	Noninverting single-ended receiver output
8	SRXDO	Differential receiver output
9	GND	Ground
10	RXD+	Noninverting input to the differential receiver. If RXD+ is greater than RXD- by more than 200mV, then the differential receiver output, SRXDO, will be high. If RXD+ is less than RXD- by more than 200mV, SRXDO will be low – meets RS-422 thresholds.
11	RXD-	Inverting input to the differential receiver – meets RS-422 thresholds.
12	HSKI	Noninverting receiver input – meets EIA/TIA-562 and EIA/TIA-232E thresholds.
13	GPI	Inverting receiver input – meets EIA/TIA-562 and EIA/TIA-232E thresholds.
14	V _{EE}	Negative supply
15	HSKO	Single-ended inverting driver output – meets EIA/TIA-562 and EIA/TIA-232E voltage levels.
16	TXD+	Noninverting differential driver output – meets RS-422 voltage levels.
17	TXD-	Inverting differential driver output – meets RS-422 voltage levels.
18	V _{CC}	Positive supply

Low-Power AppleTalk Interface Transceiver

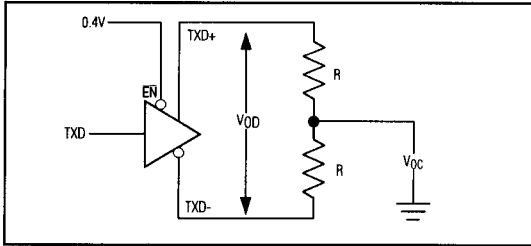

Figure 1. Differential and Common-Mode Output Voltages

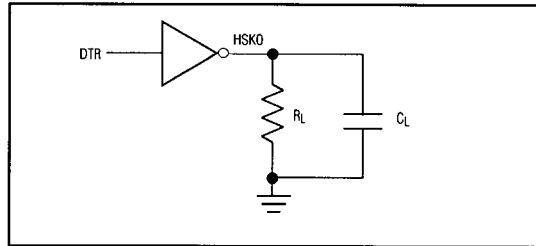

Figure 5. Single-Ended Driver Timing Test Circuit

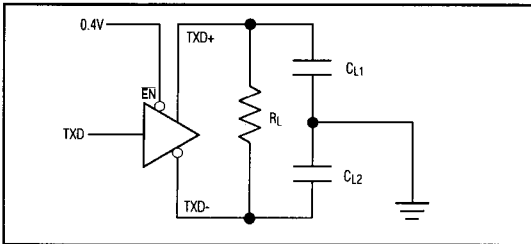

Figure 2. Differential Driver Timing Test Circuit

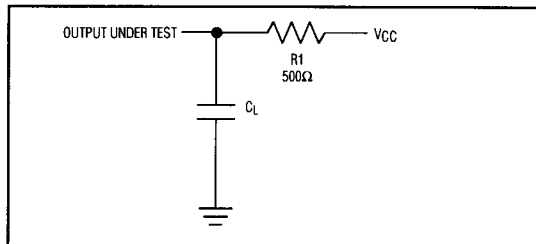

Figure 6. Receiver Enable/Disable Test Circuit 1

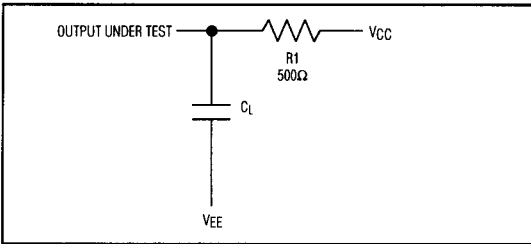

Figure 3. Driver Enable/Disable Test Circuit 1

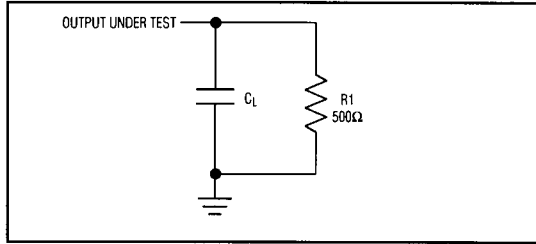

Figure 7. Receiver Enable/Disable Test Circuit 2

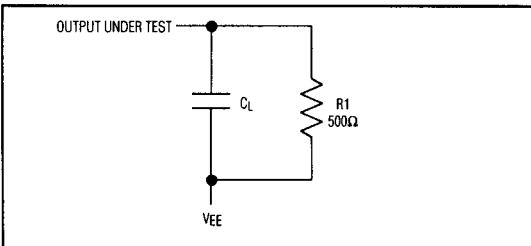

Figure 4. Driver Enable/Disable Test Circuit 2

Low-Power AppleTalk Interface Transceiver

MAX216

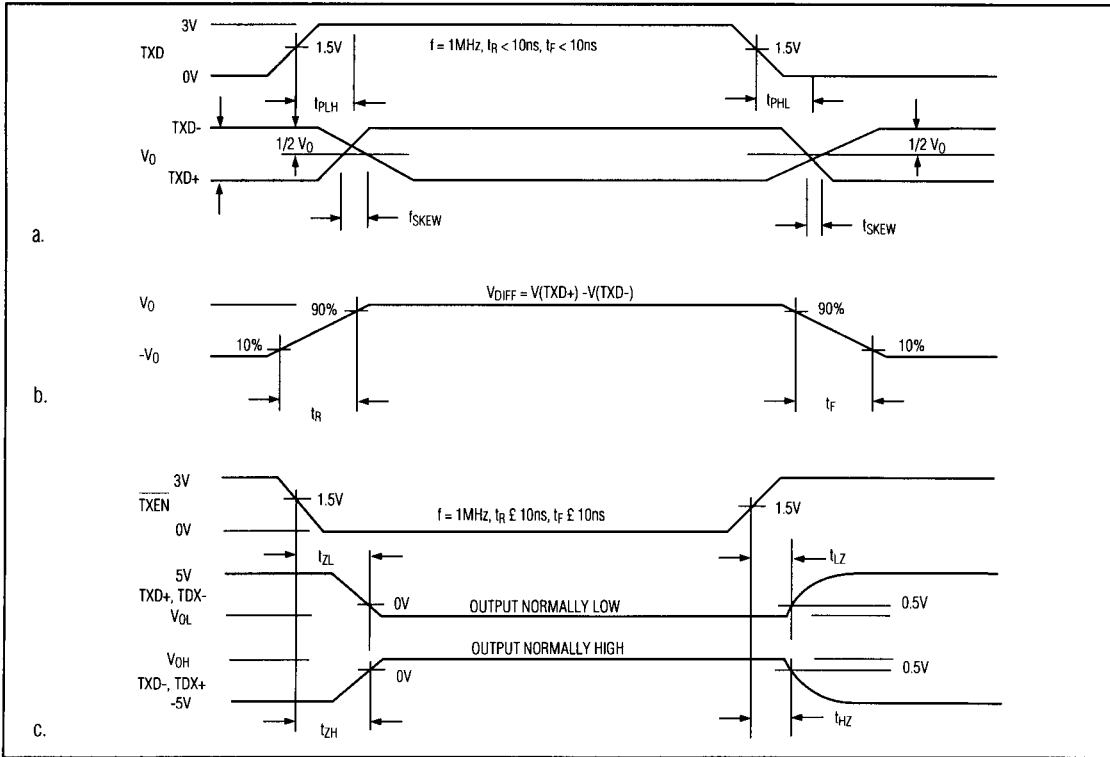

Figure 8. Differential Driver Switching Times: a) Propagation Delay and Skew; b) Rise and Fall Times; c) Enable/Disable Timing.

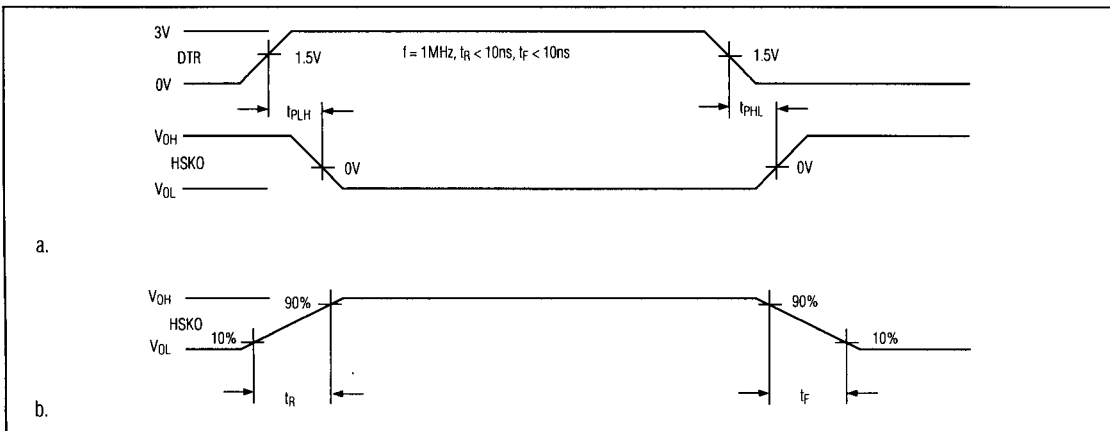

Figure 9. Single-Ended Driver Switching Times: a) Propagation Delay; b) Rise and Fall Times.

Low-Power AppleTalk Interface Transceiver

MAX216

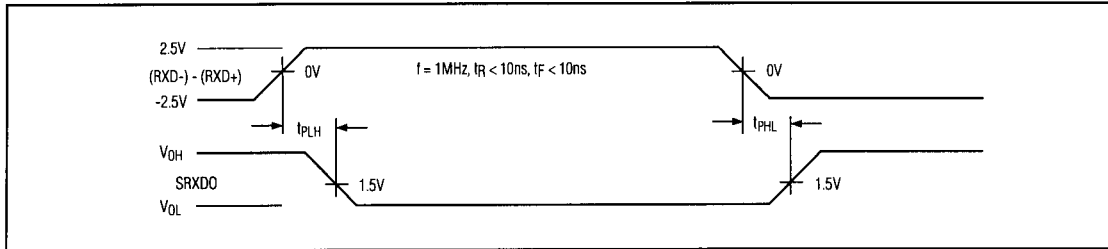

Figure 10. Differential Receiver Switching Times

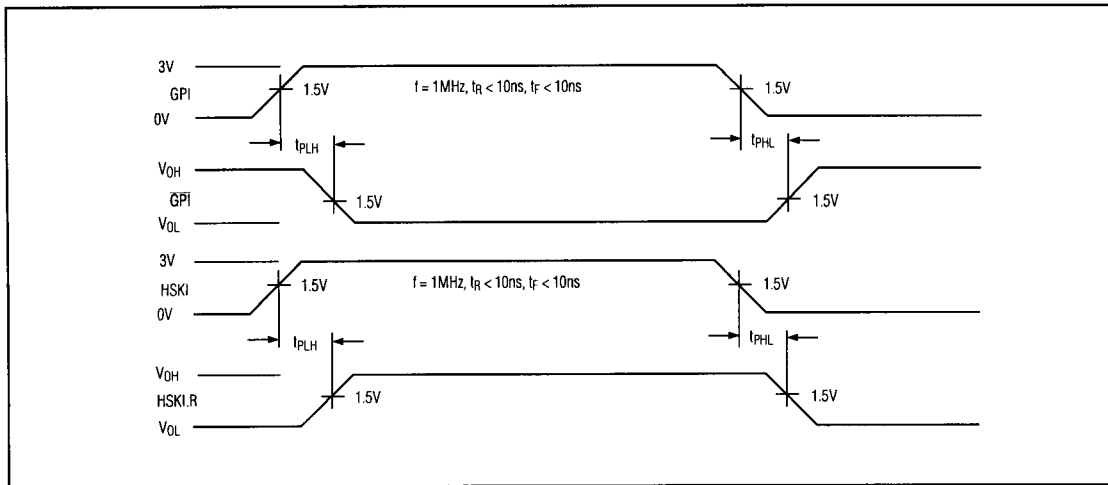

Figure 11. Single-Ended Receiver Switching Times

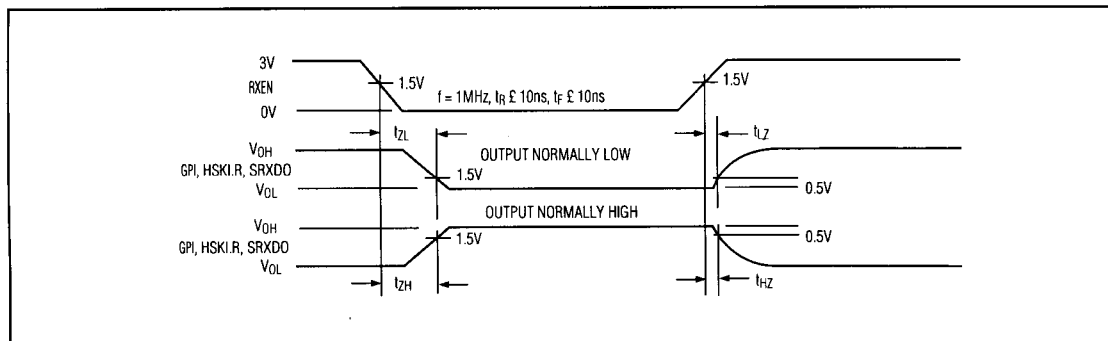

Figure 12. Receiver Enable/Disable Switching Times