

# MAX211

## 5-V MULTICHANNEL RS-232 LINE DRIVER/RECEIVER WITH $\pm 15$ -kV ESD PROTECTION

SLLS567E – MAY 2003 – REVISED JANUARY 2004

- **RS-232 Bus-Pin ESD Protection Exceeds  $\pm 15$  kV Using Human-Body Model (HBM)**
- **Meets or Exceeds the Requirements of TIA/EIA-232-F and ITU v.28 Standards**
- **Operates at 5-V  $V_{CC}$  Supply**
- **Four Drivers and Five Receivers**
- **Operates Up To 120 kbit/s**
- **Low Supply Current in Shutdown Mode . . . 1  $\mu$ A Typical**
- **External Capacitors . . .  $4 \times 0.1 \mu$ F**
- **Latch-Up Performance Exceeds 100 mA Per JESD 78, Class II**
- **Applications**
  - **Battery-Powered Systems, PDAs, Notebooks, Laptops, Palmtop PCs, and Hand-Held Equipment**

DB OR DW PACKAGE  
(TOP VIEW)

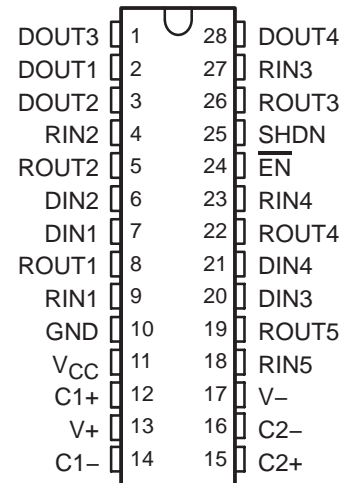

### description/ordering information

The MAX211 device consists of four line drivers, five line receivers, and a dual charge-pump circuit with  $\pm 15$ -kV ESD protection pin to pin (serial-port connection pins, including GND). The device meets the requirements of TIA/EIA-232-F and provides the electrical interface between an asynchronous communication controller and the serial-port connector. The charge pump and four small external capacitors allow operation from a single 5-V supply. The devices operate at data signaling rates up to 120 kbit/s and a maximum of 30-V/ $\mu$ s driver output slew rate.

The MAX211 has both shutdown (SHDN) and enable control ( $\overline{EN}$ ). In shutdown mode, the charge pumps are turned off,  $V+$  is pulled down to  $V_{CC}$ ,  $V-$  is pulled to GND, and the transmitter outputs are disabled. This reduces supply current typically to 1  $\mu$ A.  $\overline{EN}$  is used to put the receiver outputs into the high-impedance state to allow wired-OR connection of two RS-232 ports. It has no effect on the RS-232 drivers or the charge pumps.

### ORDERING INFORMATION

$T_A$	PACKAGE†		ORDERABLE PART NUMBER	TOP-SIDE MARKING
0°C to 70°C	SOIC (DW)	Tube of 20	MAX211CDW	MAX211C
		Reel of 1000	MAX211CDWR	
	SSOP (DB)	Tube of 50	MAX211CDB	MAX211C
		Reel of 2000	MAX211CDBR	
-40°C to 85°C	SOIC (DW)	Tube of 20	MAX211IDW	MAX211I
		Reel of 1000	MAX211IDWR	
	SSOP (DB)	Tube of 50	MAX211IDB	MAX211I
		Reel of 2000	MAX211IDBR	

† Package drawings, standard packing quantities, thermal data, symbolization, and PCB design guidelines are available at [www.ti.com/sc/package](http://www.ti.com/sc/package).



Please be aware that an important notice concerning availability, standard warranty, and use in critical applications of Texas Instruments semiconductor products and disclaimers thereto appears at the end of this data sheet.

PRODUCTION DATA information is current as of publication date. Products conform to specifications per the terms of Texas Instruments standard warranty. Production processing does not necessarily include testing of all parameters.



POST OFFICE BOX 655303 • DALLAS, TEXAS 75265

Copyright © 2004, Texas Instruments Incorporated

**MAX211**  
**5-V MULTICHANNEL RS-232 LINE DRIVER/RECEIVER**  
**WITH ±15-kV ESD PROTECTION**

SLLS567E – MAY 2003 – REVISED JANUARY 2004

**Function Tables**

INPUTS		DRIVER	RECEIVER	DEVICE STATUS
SHDN	$\overline{\text{EN}}$			
L	L	All active	All active	Normal operation
L	H	All active	Z	Normal operation
H	X	Z	Z	Shutdown

X = don't care, Z = high impedance

**EACH DRIVER**

INPUTS		OUTPUT DOUT	DRIVER STATUS
DIN	SHDN		
L	L	H	Normal operation
H	L	L	
X	H	Z	Powered off

X = don't care, Z = high impedance

**EACH RECEIVER**

INPUTS		OUTPUT ROUT	RECEIVER STATUS
RIN	$\overline{\text{EN}}$		
L	L	H	Normal operation
H	L	L	
X	H	Z	Powered off

X = don't care, Z = high impedance



**MAX211**  
**5-V MULTICHANNEL RS-232 LINE DRIVER/RECEIVER**  
**WITH ±15-kV ESD PROTECTION**

SLLS567E – MAY 2003 – REVISED JANUARY 2004

logic diagram (positive logic)

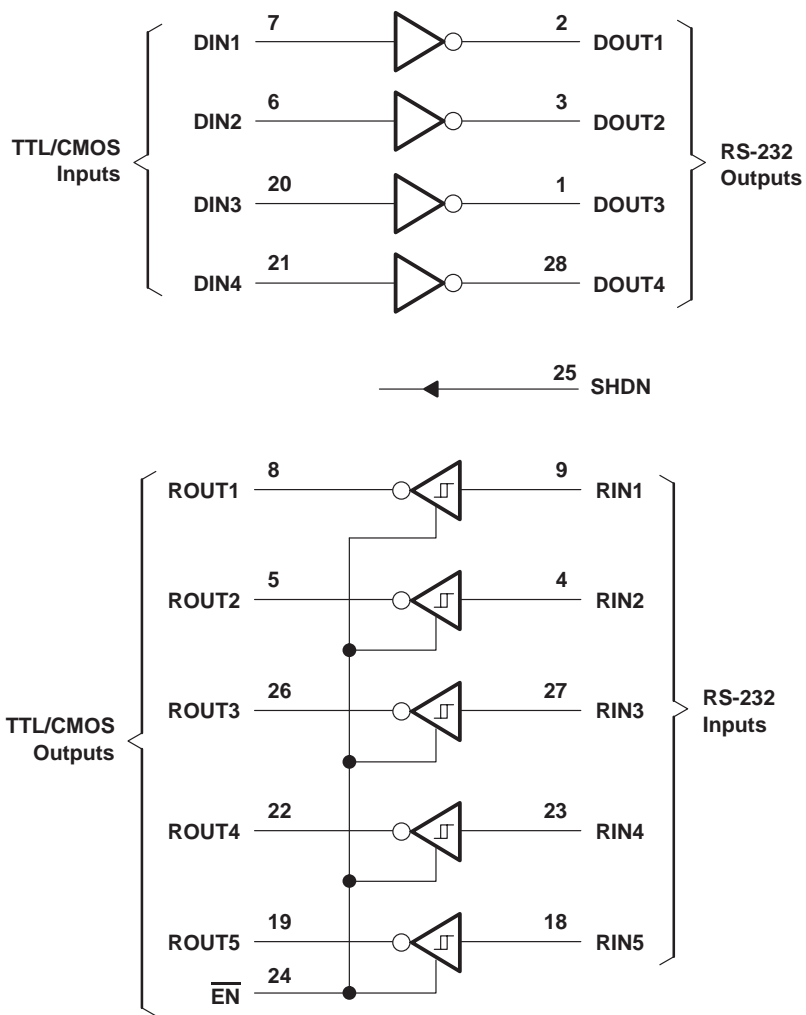

**MAX211**  
**5-V MULTICHANNEL RS-232 LINE DRIVER/RECEIVER**  
**WITH ±15-kV ESD PROTECTION**

SLLS567E – MAY 2003 – REVISED JANUARY 2004

**absolute maximum ratings over operating free-air temperature range (unless otherwise noted)†**

Supply voltage range, $V_{CC}$ (see Note 1)	.....	-0.3 V to 6 V
Positive charge pump voltage range, $V_+$ (see Note 1)	.....	$V_{CC} - 0.3$ V to 14 V
Negative charge pump voltage range, $V_-$ (see Note 1)	.....	0.3 V to -14 V
Input voltage range, $V_I$ : Drivers	.....	-0.3 V to $V_+ + 0.3$ V
Receivers	.....	±30 V
Output voltage range, $V_O$ : Drivers	.....	$V_- - 0.3$ V to $V_+ + 0.3$ V
Receivers	.....	-0.3 V to $V_{CC} + 0.3$ V
Short-circuit duration: DOUT	.....	Continuous
Package thermal impedance, $\theta_{JA}$ (see Notes 2 and 3): DB package	.....	62°C/W
DW package	.....	46°C/W
Operating virtual junction temperature, $T_J$	.....	150°C
Storage temperature range, $T_{stg}$	.....	-65°C to 150°C

† Stresses beyond those listed under “absolute maximum ratings” may cause permanent damage to the device. These are stress ratings only, and functional operation of the device at these or any other conditions beyond those indicated under “recommended operating conditions” is not implied. Exposure to absolute-maximum-rated conditions for extended periods may affect device reliability.

- NOTES: 1. All voltages are with respect to network GND.  
2. Maximum power dissipation is a function of  $T_J(\text{max})$ ,  $\theta_{JA}$ , and  $T_A$ . The maximum allowable power dissipation at any allowable ambient temperature is  $P_D = (T_J(\text{max}) - T_A)/\theta_{JA}$ . Operating at the absolute maximum  $T_J$  of 150°C can affect reliability.  
3. The package thermal impedance is calculated in accordance with JESD 51-7.

**recommended operating conditions (see Note 4 and Figure 4)**

			MIN	NOM	MAX	UNIT
Supply voltage			4.5	5	5.5	V
$V_{IH}$	Driver high-level input voltage	DIN	2		V	
	Control high-level input voltage	$\overline{EN}$ , SHDN	2.4			
$V_{IL}$	Driver and control low-level input voltage	DIN, $\overline{EN}$ , SHDN	0.8		V	
$V_I$	Driver and control input voltage	DIN, $\overline{EN}$ , SHDN	0	5.5	V	
	Receiver input voltage		-30	30		
$T_A$	Operating free-air temperature	MAX211C	0	70	°C	
		MAX211I	-40	85		

NOTE 4: Test conditions are C1–C4 = 0.1  $\mu$ F at  $V_{CC} = 5$  V  $\pm$  0.5 V.

**electrical characteristics over recommended ranges of supply voltage and operating free-air temperature (unless otherwise noted) (see Note 4)**

PARAMETER		TEST CONDITIONS		MIN	TYP‡	MAX	UNIT
$I_{CC}$	Supply current	No load,	See Figure 6		14	20	mA
	Shutdown supply current	$T_A = 25^\circ\text{C}$ ,	See Figure 1		1	10	$\mu$ A

‡ All typical values are at  $V_{CC} = 5$  V, and  $T_A = 25^\circ\text{C}$ .

NOTE 4: Test conditions are C1–C4 = 0.1  $\mu$ F at  $V_{CC} = 5$  V  $\pm$  0.5 V.



# MAX211

## 5-V MULTICHANNEL RS-232 LINE DRIVER/RECEIVER WITH $\pm 15$ -kV ESD PROTECTION

SLLS567E – MAY 2003 – REVISED JANUARY 2004

### DRIVER SECTION

**electrical characteristics over recommended ranges of supply voltage and operating free-air temperature (unless otherwise noted) (see Note 4 and Figure 4)**

PARAMETER		TEST CONDITIONS	MIN	TYP†	MAX	UNIT
$V_{OH}$	High-level output voltage	DOUT at $R_L = 3\text{ k}\Omega$ to GND	5	9		V
$V_{OL}$	Low-level output voltage	DOUT at $R_L = 3\text{ k}\Omega$ to GND	-5	-9		V
$I_{IH}$	Driver high-level input current	$DIN = V_{CC}$		15	200	$\mu\text{A}$
	Control high-level input current	$\overline{EN}, SHDN = V_{CC}$		3	10	
$I_{IL}$	Driver low-level input current	$DIN = 0\text{ V}$		-15	-200	$\mu\text{A}$
	Control low-level input current	$\overline{EN}, SHDN = 0\text{ V}$		-3	-10	
$I_{OS}^\ddagger$	Short-circuit output current	$V_{CC} = 5.5\text{ V},$ $V_O = 0\text{ V}$		$\pm 10$	$\pm 60$	mA
$r_o$	Output resistance	$V_{CC}, V+,$ and $V- = 0\text{ V},$ $V_O = \pm 2\text{ V}$	300			$\Omega$

† All typical values are at  $V_{CC} = 5\text{ V}$ , and  $T_A = 25^\circ\text{C}$ .

‡ Short-circuit durations should be controlled to prevent exceeding the device absolute power dissipation ratings, and not more than one output should be shorted at a time.

NOTE 4: Test conditions are C1–C4 = 0.1  $\mu\text{F}$  at  $V_{CC} = 5\text{ V} \pm 0.5\text{ V}$ .

**switching characteristics over recommended ranges of supply voltage and operating free-air temperature (unless otherwise noted) (see Note 4)**

PARAMETER		TEST CONDITIONS	MIN	TYP†	MAX	UNIT
	Maximum data rate	$C_L = 50\text{ pF}$ to 1000 pF, One DOUT switching, $R_L = 3\text{ k}\Omega$ to 7 k $\Omega$ , See Figure 2	120			kbit/s
$t_{PLH}$ (D)	Propagation delay time, low- to high-level output	$C_L = 2500\text{ pF},$ All drivers loaded, $R_L = 3\text{ k}\Omega$ , See Figure 2		2		$\mu\text{s}$
$t_{PHL}$ (D)	Propagation delay time, high- to low-level output	$C_L = 2500\text{ pF},$ All drivers loaded, $R_L = 3\text{ k}\Omega$ , See Figure 2		2		$\mu\text{s}$
$t_{sk(p)}$	Pulse skew§	$C_L = 150\text{ pF}$ to 2500 pF, $R_L = 3\text{ k}\Omega$ to 7 k $\Omega$ , See Figure 3		300		ns
SR(tr)	Slew rate, transition region (see Figure 2)	$C_L = 50\text{ pF}$ to 1000 pF, $V_{CC} = 5\text{ V}$ $R_L = 3\text{ k}\Omega$ to 7 k $\Omega$ ,	3	6	30	V/ $\mu\text{s}$

† All typical values are at  $V_{CC} = 5\text{ V}$ , and  $T_A = 25^\circ\text{C}$ .

§ Pulse skew is defined as  $|t_{PLH} - t_{PHL}|$  of each channel of the same device.

NOTE 4: Test conditions are C1–C4 = 0.1  $\mu\text{F}$  at  $V_{CC} = 5\text{ V} \pm 0.5\text{ V}$ .

### ESD protection

PIN	TEST CONDITIONS	TYP	UNIT
DOUT, R <sub>IN</sub>	Human-Body Model	$\pm 15$	kV



**MAX211**  
**5-V MULTICHANNEL RS-232 LINE DRIVER/RECEIVER**  
**WITH  $\pm 15$ -kV ESD PROTECTION**

SLLS567E – MAY 2003 – REVISED JANUARY 2004

**RECEIVER SECTION**

**electrical characteristics over recommended ranges of supply voltage and operating free-air temperature (unless otherwise noted) (see Note 4 and Figure 6)**

PARAMETER		TEST CONDITIONS	MIN	TYP†	MAX	UNIT
V <sub>OH</sub>	High-level output voltage	I <sub>OH</sub> = -1 mA	3.5	V <sub>CC</sub> -0.4V		V
V <sub>OL</sub>	Low-level output voltage	I <sub>OL</sub> = 1.6 mA			0.4	V
V <sub>IT+</sub>	Positive-going input threshold voltage	V <sub>CC</sub> = 5 V, T <sub>A</sub> = 25°C		1.7	2.4	V
V <sub>IT-</sub>	Negative-going input threshold voltage	V <sub>CC</sub> = 5 V, T <sub>A</sub> = 25°C	0.8	1.2		V
V <sub>hys</sub>	Input hysteresis (V <sub>IT+</sub> - V <sub>IT-</sub> )		0.2	0.5	1	V
r <sub>i</sub>	Input resistance	V <sub>CC</sub> = 5 V, T <sub>A</sub> = 25°C	3	5	7	kΩ
	Output leakage current	$\overline{EN} = V_{CC}$ , 0 ≤ R <sub>OUT</sub> ≤ V <sub>CC</sub>		±0.05	±10	μA

† All typical values are at V<sub>CC</sub> = 5 V, and T<sub>A</sub> = 25°C.

NOTE 4: Test conditions are C1-C4 = 0.1 μF at V<sub>CC</sub> = 5 V ± 0.5 V.

**switching characteristics over recommended ranges of supply voltage and operating free-air temperature (unless otherwise noted) (see Note 4)**

PARAMETER		TEST CONDITIONS	MIN	TYP†	MAX	UNIT
t <sub>PLH</sub> (R)	Propagation delay time, low- to high-level output	C <sub>L</sub> = 150 pF, See Figure 4		0.5	10	μs
t <sub>PHL</sub> (R)	Propagation delay time, high- to low-level output	C <sub>L</sub> = 150 pF, See Figure 4		0.5	10	μs
t <sub>en</sub>	Output enable time	C <sub>L</sub> = 150 pF, R <sub>L</sub> = 1 kΩ, See Figure 5		600		ns
t <sub>dis</sub>	Output disable time	C <sub>L</sub> = 150 pF, R <sub>L</sub> = 1 kΩ, See Figure 5		200		ns
t <sub>sk(p)</sub>	Pulse skew‡	See Figure 3		300		ns

† All typical values are at V<sub>CC</sub> = 5 V, and T<sub>A</sub> = 25°C.

‡ Pulse skew is defined as |t<sub>PLH</sub> - t<sub>PHL</sub>| of each channel of the same device.

NOTE 4: Test conditions are C1-C4 = 0.1 μF, at V<sub>CC</sub> = 5 V ± 0.5 V.

**MAX211**  
**5-V MULTICHANNEL RS-232 LINE DRIVER/RECEIVER**  
**WITH  $\pm 15$ -kV ESD PROTECTION**

SLLS567E – MAY 2003 – REVISED JANUARY 2004

**PARAMETER MEASUREMENT INFORMATION**

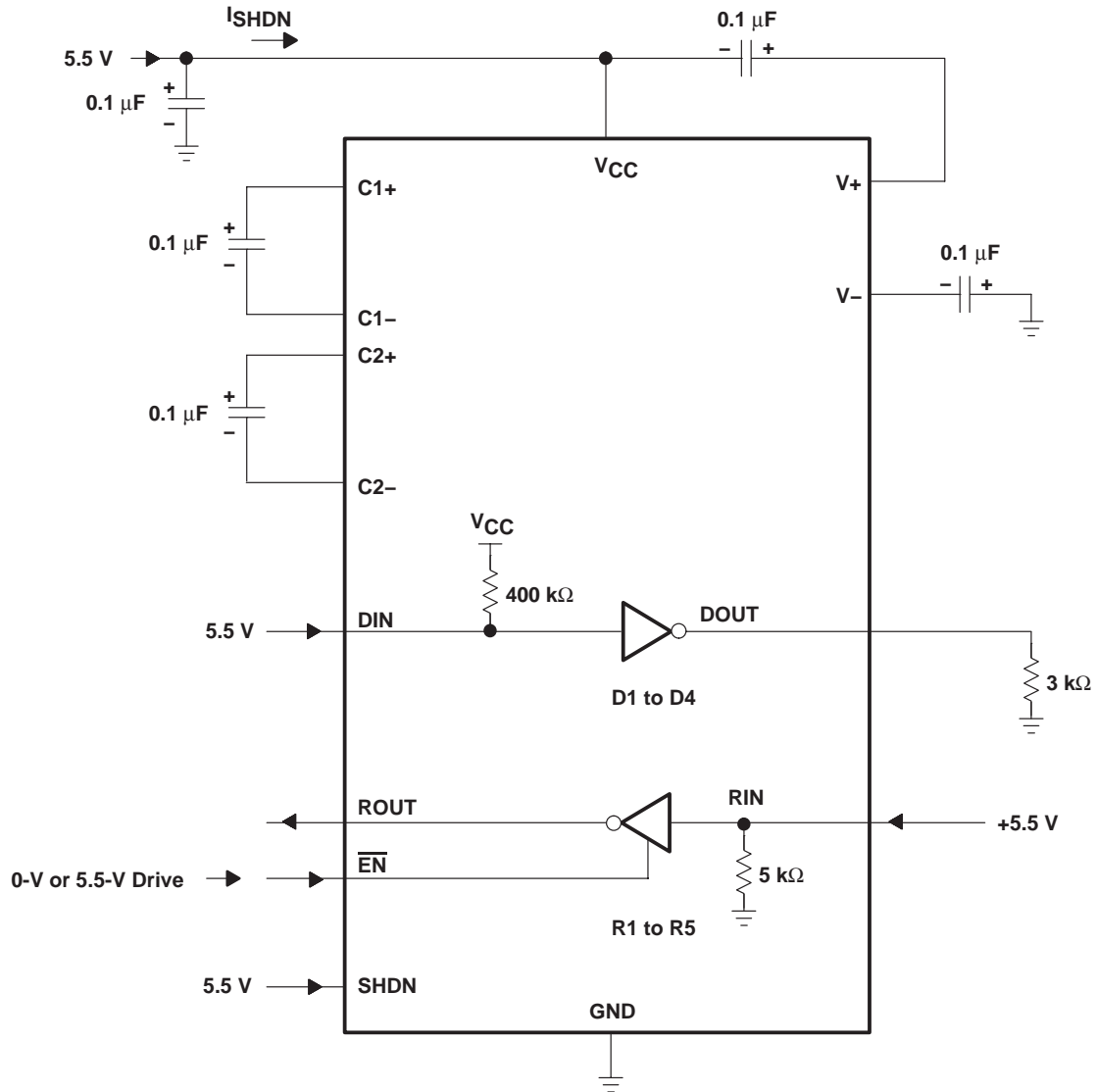
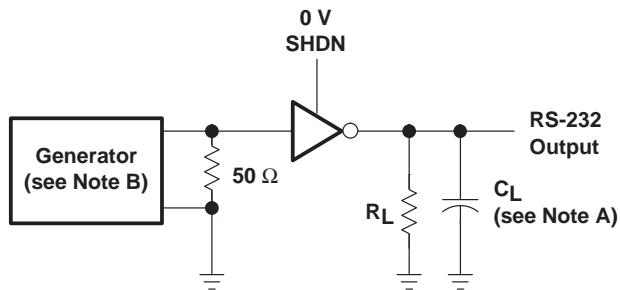

Figure 1. Shutdown Current Test Circuit

**MAX211**  
**5-V MULTICHANNEL RS-232 LINE DRIVER/RECEIVER**  
**WITH ±15-kV ESD PROTECTION**

SLLS567E – MAY 2003 – REVISED JANUARY 2004

**PARAMETER MEASUREMENT INFORMATION**



TEST CIRCUIT

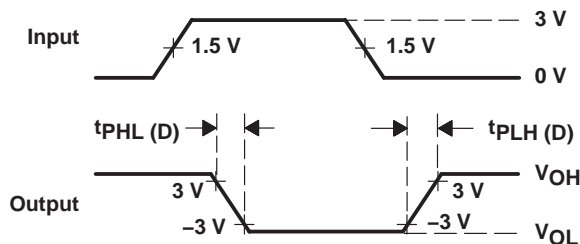

VOLTAGE WAVEFORMS

$$SR(tr) = \frac{6\text{ V}}{t_{PHL(D)} \text{ or } t_{PLH(D)}}$$

- NOTES: A.  $C_L$  includes probe and jig capacitance.  
 B. The pulse generator has the following characteristics: PRR = 120 kbit/s,  $Z_O = 50\ \Omega$ , 50% duty cycle,  $t_r \leq 10\text{ ns}$ ,  $t_f \leq 10\text{ ns}$ .

**Figure 2. Driver Slew Rate and Propagation Delay Times**

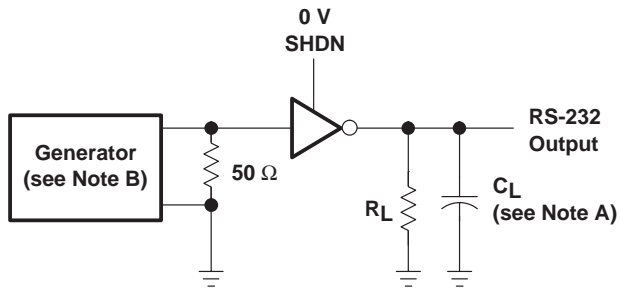

TEST CIRCUIT

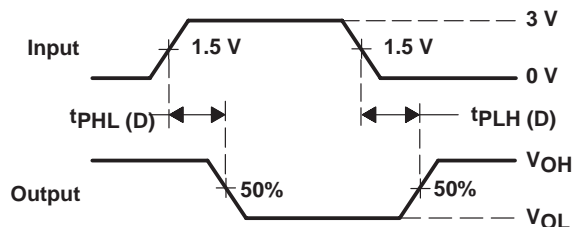

VOLTAGE WAVEFORMS

- NOTES: A.  $C_L$  includes probe and jig capacitance.  
 B. The pulse generator has the following characteristics: PRR = 120 kbit/s,  $Z_O = 50\ \Omega$ , 50% duty cycle,  $t_r \leq 10\text{ ns}$ ,  $t_f \leq 10\text{ ns}$ .

**Figure 3. Driver Pulse Skew**

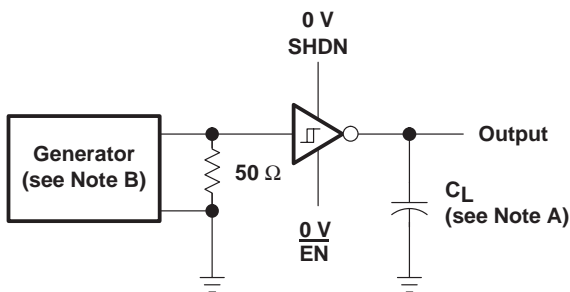

TEST CIRCUIT

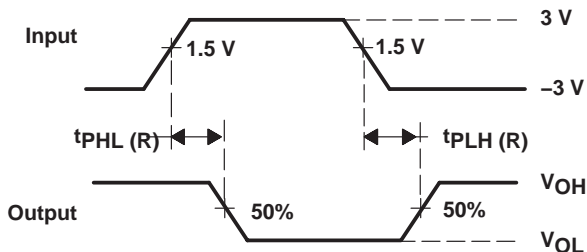

VOLTAGE WAVEFORMS

- NOTES: A.  $C_L$  includes probe and jig capacitance.  
 B. The pulse generator has the following characteristics:  $Z_O = 50\ \Omega$ , 50% duty cycle,  $t_r \leq 10\text{ ns}$ ,  $t_f \leq 10\text{ ns}$ .

**Figure 4. Receiver Propagation Delay Times**



**PARAMETER MEASUREMENT INFORMATION**

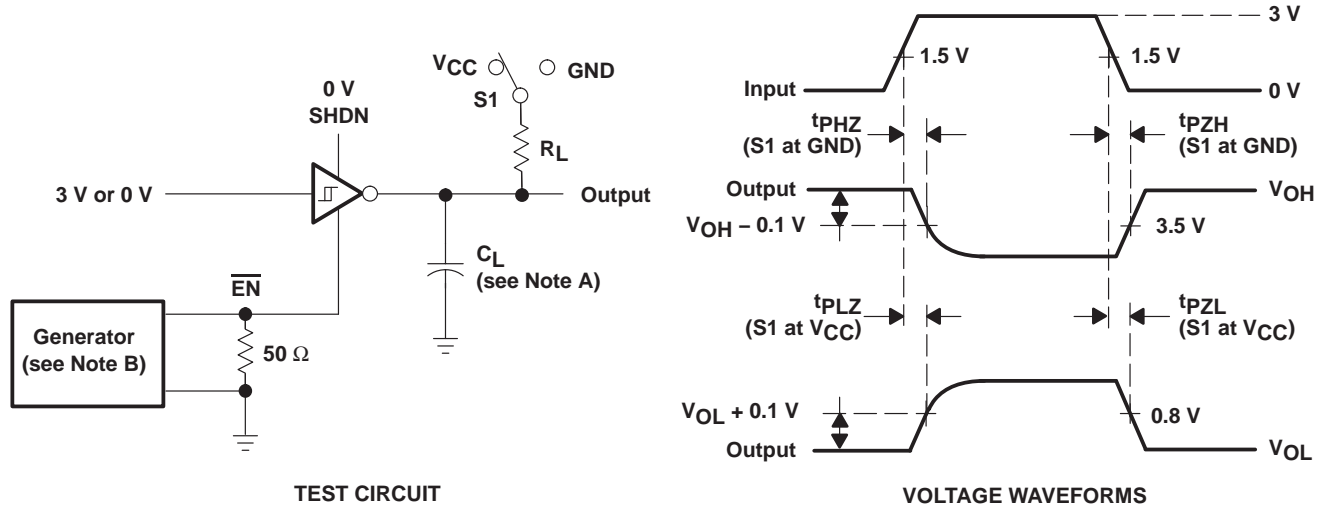

- NOTES: A.  $C_L$  includes probe and jig capacitance.  
 B. The pulse generator has the following characteristics:  $Z_O = 50 \Omega$ , 50% duty cycle,  $t_r \leq 10$  ns,  $t_f \leq 10$  ns.  
 C.  $t_{PLZ}$  and  $t_{PHZ}$  are the same as  $t_{dis}$ .  
 D.  $t_{PZL}$  and  $t_{PZH}$  are the same as  $t_{en}$ .

**Figure 5. Receiver Enable and Disable Times**

**MAX211**  
**5-V MULTICHANNEL RS-232 LINE DRIVER/RECEIVER**  
**WITH  $\pm 15$ -kV ESD PROTECTION**

SLLS567E – MAY 2003 – REVISED JANUARY 2004

**APPLICATION INFORMATION**

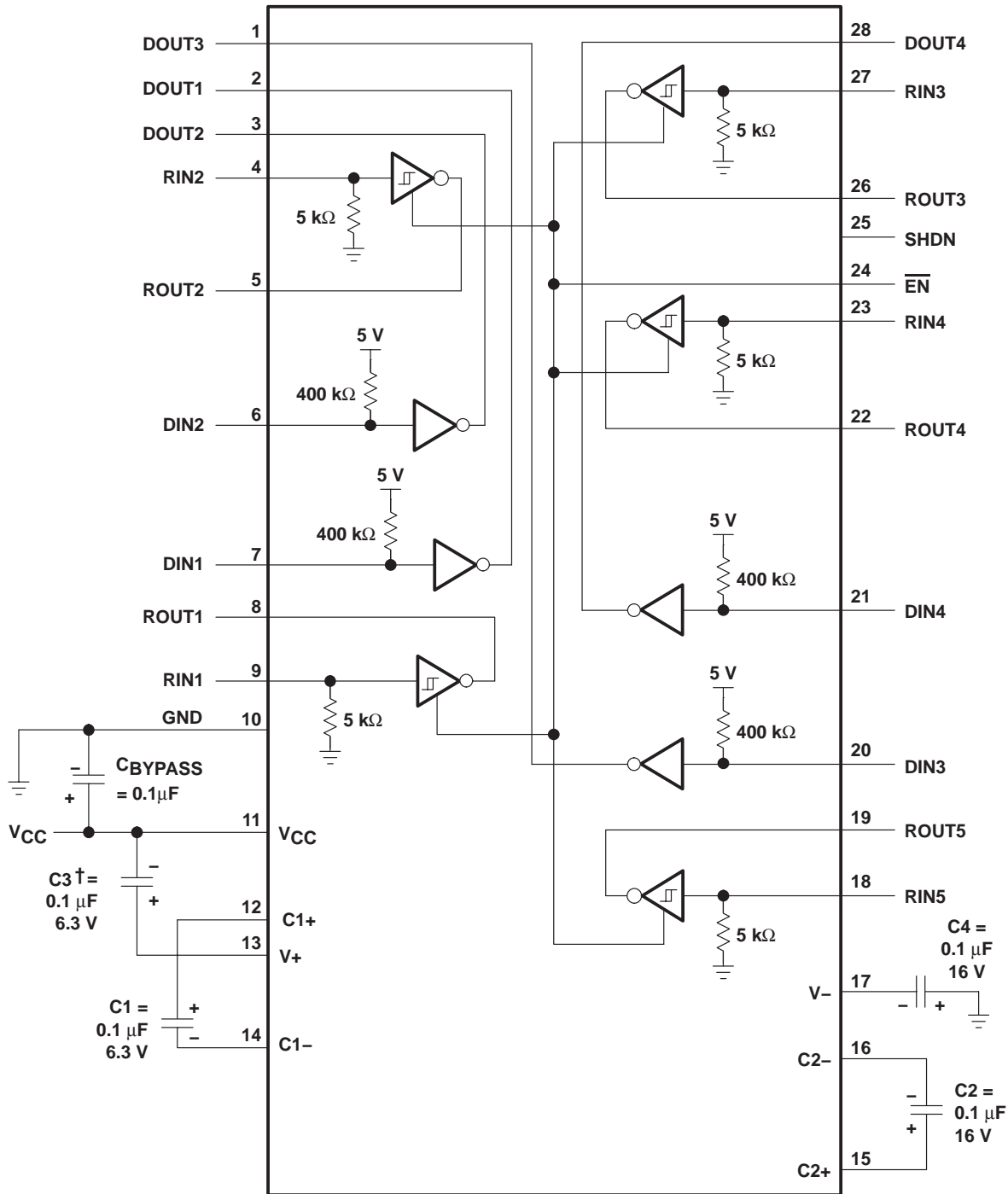

† C3 can be connected to  $V_{CC}$  or GND.

NOTES: A. Resistor values shown are nominal.

B. Nonpolarized ceramic capacitors are acceptable. If polarized tantalum or electrolytic capacitors are used, they should be connected as shown.

**Figure 6. Typical Operating Circuit and Capacitor Values**



## APPLICATION INFORMATION

### capacitor selection

The capacitor type used for C1–C4 is not critical for proper operation. The MAX211 requires 0.1- $\mu\text{F}$  capacitors, although capacitors up to 10  $\mu\text{F}$  can be used without harm. Ceramic dielectrics are suggested for the 0.1- $\mu\text{F}$  capacitors. When using the minimum recommended capacitor values, make sure the capacitance value does not degrade excessively as the operating temperature varies. If in doubt, use capacitors with a larger (e.g., 2 $\times$ ) nominal value. The capacitors' effective series resistance (ESR), which usually rises at low temperatures, influences the amount of ripple on V+ and V–.

Use larger capacitors (up to 10  $\mu\text{F}$ ) to reduce the output impedance at V+ and V–.

Bypass  $V_{CC}$  to ground with at least 0.1  $\mu\text{F}$ . In applications sensitive to power-supply noise generated by the charge pumps, decouple  $V_{CC}$  to ground with a capacitor the same size as (or larger than) the charge-pump capacitors (C1–C4).

### electrostatic discharge (ESD) protection

Texas Instruments MAX211 devices have standard ESD protection structures incorporated on the pins to protect against electrostatic discharges encountered during assembly and handling. In addition, the RS232 bus pins (driver outputs and receiver inputs) of these devices have an extra level of ESD protection. Advanced ESD structures were designed to successfully protect these bus pins against ESD discharge of  $\pm 15$  kV when powered down.

### ESD test conditions

ESD testing is stringently performed by TI, based on various conditions and procedures. Please contact TI for a reliability report that documents test setup, methodology, and results.

### Human-Body Model

The Human-Body Model (HBM) of ESD testing is shown in Figure 7. Figure 8 shows the current waveform that is generated during a discharge into a low impedance. The model consists of a 100-pF capacitor charged to the ESD voltage of concern and subsequently discharged into the DUT through a 1.5-k $\Omega$  resistor.

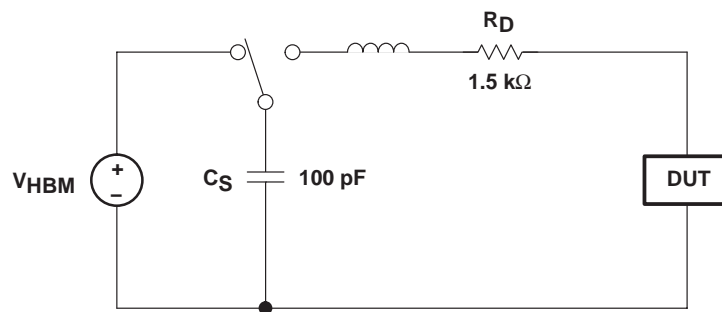
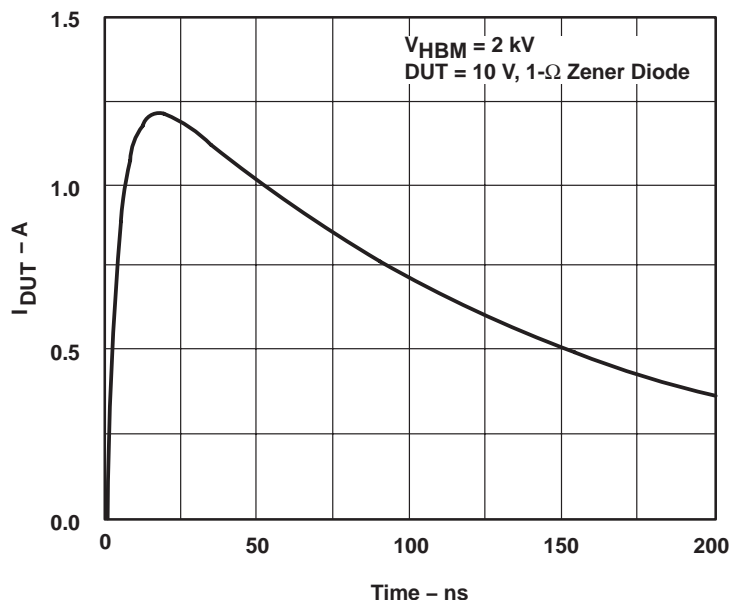

Figure 7. HBM ESD Test Circuit

**MAX211**  
**5-V MULTICHANNEL RS-232 LINE DRIVER/RECEIVER**  
**WITH  $\pm 15$ -kV ESD PROTECTION**

SLLS567E – MAY 2003 – REVISED JANUARY 2004

**APPLICATION INFORMATION**



**Figure 8. Typical HBM Current Waveform**

**Machine Model**

The Machine Model (MM) ESD test applies to all pins, using a 200-pF capacitor with no discharge resistance. The purpose of the MM test is to simulate possible ESD conditions that can occur during the handling and assembly processes of manufacturing. In this case, ESD protection is required for all pins, not just RS-232 pins. However, after PC board assembly, the MM test no longer is as pertinent to the RS-232 pins.

**PACKAGING INFORMATION**

Orderable Device	Status <sup>(1)</sup>	Package Type	Package Drawing	Pins	Package Qty	Eco Plan <sup>(2)</sup>	Lead/Ball Finish	MSL Peak Temp <sup>(3)</sup>
MAX211CDB	ACTIVE	SSOP	DB	28	50	Green (RoHS & no Sb/Br)	CU NIPDAU	Level-1-260C-UNLIM
MAX211CDBE4	ACTIVE	SSOP	DB	28	50	Green (RoHS & no Sb/Br)	CU NIPDAU	Level-1-260C-UNLIM
MAX211CDBG4	ACTIVE	SSOP	DB	28	50	Green (RoHS & no Sb/Br)	CU NIPDAU	Level-1-260C-UNLIM
MAX211CDBR	ACTIVE	SSOP	DB	28	2000	Green (RoHS & no Sb/Br)	CU NIPDAU	Level-1-260C-UNLIM
MAX211CDBRE4	ACTIVE	SSOP	DB	28	2000	Green (RoHS & no Sb/Br)	CU NIPDAU	Level-1-260C-UNLIM
MAX211CDBRG4	ACTIVE	SSOP	DB	28	2000	Green (RoHS & no Sb/Br)	CU NIPDAU	Level-1-260C-UNLIM
MAX211CDW	ACTIVE	SOIC	DW	28	20	Green (RoHS & no Sb/Br)	CU NIPDAU	Level-1-260C-UNLIM
MAX211CDWE4	ACTIVE	SOIC	DW	28	20	Green (RoHS & no Sb/Br)	CU NIPDAU	Level-1-260C-UNLIM
MAX211CDWG4	ACTIVE	SOIC	DW	28	20	Green (RoHS & no Sb/Br)	CU NIPDAU	Level-1-260C-UNLIM
MAX211CDWR	ACTIVE	SOIC	DW	28	1000	Green (RoHS & no Sb/Br)	CU NIPDAU	Level-1-260C-UNLIM
MAX211CDWRE4	ACTIVE	SOIC	DW	28	1000	Green (RoHS & no Sb/Br)	CU NIPDAU	Level-1-260C-UNLIM
MAX211CDWRG4	ACTIVE	SOIC	DW	28	1000	Green (RoHS & no Sb/Br)	CU NIPDAU	Level-1-260C-UNLIM
MAX211IDB	ACTIVE	SSOP	DB	28	50	Green (RoHS & no Sb/Br)	CU NIPDAU	Level-1-260C-UNLIM
MAX211IDBE4	ACTIVE	SSOP	DB	28	50	Green (RoHS & no Sb/Br)	CU NIPDAU	Level-1-260C-UNLIM
MAX211IDBG4	ACTIVE	SSOP	DB	28	50	Green (RoHS & no Sb/Br)	CU NIPDAU	Level-1-260C-UNLIM
MAX211IDBR	ACTIVE	SSOP	DB	28	2000	Green (RoHS & no Sb/Br)	CU NIPDAU	Level-1-260C-UNLIM
MAX211IDBRE4	ACTIVE	SSOP	DB	28	2000	Green (RoHS & no Sb/Br)	CU NIPDAU	Level-1-260C-UNLIM
MAX211IDBRG4	ACTIVE	SSOP	DB	28	2000	Green (RoHS & no Sb/Br)	CU NIPDAU	Level-1-260C-UNLIM
MAX211IDW	ACTIVE	SOIC	DW	28	20	Green (RoHS & no Sb/Br)	CU NIPDAU	Level-1-260C-UNLIM
MAX211IDWE4	ACTIVE	SOIC	DW	28	20	Green (RoHS & no Sb/Br)	CU NIPDAU	Level-1-260C-UNLIM
MAX211IDWG4	ACTIVE	SOIC	DW	28	20	Green (RoHS & no Sb/Br)	CU NIPDAU	Level-1-260C-UNLIM
MAX211IDWR	ACTIVE	SOIC	DW	28	1000	Green (RoHS & no Sb/Br)	CU NIPDAU	Level-1-260C-UNLIM
MAX211IDWRE4	ACTIVE	SOIC	DW	28	1000	Green (RoHS & no Sb/Br)	CU NIPDAU	Level-1-260C-UNLIM
MAX211IDWRG4	ACTIVE	SOIC	DW	28	1000	Green (RoHS & no Sb/Br)	CU NIPDAU	Level-1-260C-UNLIM

<sup>(1)</sup> The marketing status values are defined as follows:

**ACTIVE:** Product device recommended for new designs.

**LIFEBUY:** TI has announced that the device will be discontinued, and a lifetime-buy period is in effect.

**NRND:** Not recommended for new designs. Device is in production to support existing customers, but TI does not recommend using this part in a new design.

**PREVIEW:** Device has been announced but is not in production. Samples may or may not be available.

**OBSOLETE:** TI has discontinued the production of the device.

<sup>(2)</sup> Eco Plan - The planned eco-friendly classification: Pb-Free (RoHS), Pb-Free (RoHS Exempt), or Green (RoHS & no Sb/Br) - please check <http://www.ti.com/productcontent> for the latest availability information and additional product content details.

**TBD:** The Pb-Free/Green conversion plan has not been defined.

**Pb-Free (RoHS):** TI's terms "Lead-Free" or "Pb-Free" mean semiconductor products that are compatible with the current RoHS requirements for all 6 substances, including the requirement that lead not exceed 0.1% by weight in homogeneous materials. Where designed to be soldered at high temperatures, TI Pb-Free products are suitable for use in specified lead-free processes.

**Pb-Free (RoHS Exempt):** This component has a RoHS exemption for either 1) lead-based flip-chip solder bumps used between the die and package, or 2) lead-based die adhesive used between the die and leadframe. The component is otherwise considered Pb-Free (RoHS compatible) as defined above.

**Green (RoHS & no Sb/Br):** TI defines "Green" to mean Pb-Free (RoHS compatible), and free of Bromine (Br) and Antimony (Sb) based flame retardants (Br or Sb do not exceed 0.1% by weight in homogeneous material)

<sup>(3)</sup> MSL, Peak Temp. -- The Moisture Sensitivity Level rating according to the JEDEC industry standard classifications, and peak solder temperature.

**Important Information and Disclaimer:**The information provided on this page represents TI's knowledge and belief as of the date that it is provided. TI bases its knowledge and belief on information provided by third parties, and makes no representation or warranty as to the accuracy of such information. Efforts are underway to better integrate information from third parties. TI has taken and continues to take reasonable steps to provide representative and accurate information but may not have conducted destructive testing or chemical analysis on incoming materials and chemicals. TI and TI suppliers consider certain information to be proprietary, and thus CAS numbers and other limited information may not be available for release.

In no event shall TI's liability arising out of such information exceed the total purchase price of the TI part(s) at issue in this document sold by TI to Customer on an annual basis.



Carrier tape design is defined largely by the component length, width, and thickness.

$A_o$ = Dimension designed to accommodate the component width.
$B_o$ = Dimension designed to accommodate the component length.
$K_o$ = Dimension designed to accommodate the component thickness.
$W$ = Overall width of the carrier tape.
$P$ = Pitch between successive cavity centers.



**TAPE AND REEL INFORMATION**

Device	Package	Pins	Site	Reel Diameter (mm)	Reel Width (mm)	A0 (mm)	B0 (mm)	K0 (mm)	P1 (mm)	W (mm)	Pin1 Quadrant
MAX211CDBR	DB	28	MLA	330	16	8.2	10.5	2.5	12	16	Q1
MAX211CDWR	DW	28	TAI	330	32	11.35	18.67	3.1	16	32	Q1
MAX211IDBR	DB	28	MLA	330	16	8.2	10.5	2.5	12	16	Q1
MAX211IDWR	DW	28	TAI	330	32	11.35	18.67	3.1	16	32	Q1

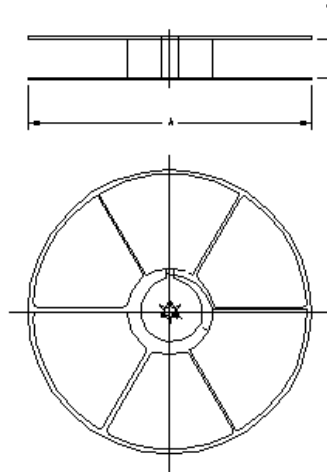

**TAPE AND REEL BOX INFORMATION**

Device	Package	Pins	Site	Length (mm)	Width (mm)	Height (mm)
MAX211CDBR	DB	28	MLA	342.9	336.6	28.58
MAX211CDWR	DW	28	TAI	346.0	346.0	49.0
MAX211IDBR	DB	28	MLA	342.9	336.6	28.58
MAX211IDWR	DW	28	TAI	346.0	346.0	49.0



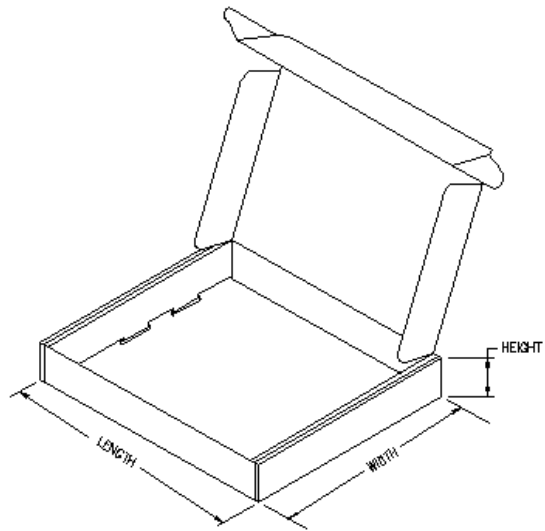

DW (R-PDSO-G28)

PLASTIC SMALL-OUTLINE PACKAGE

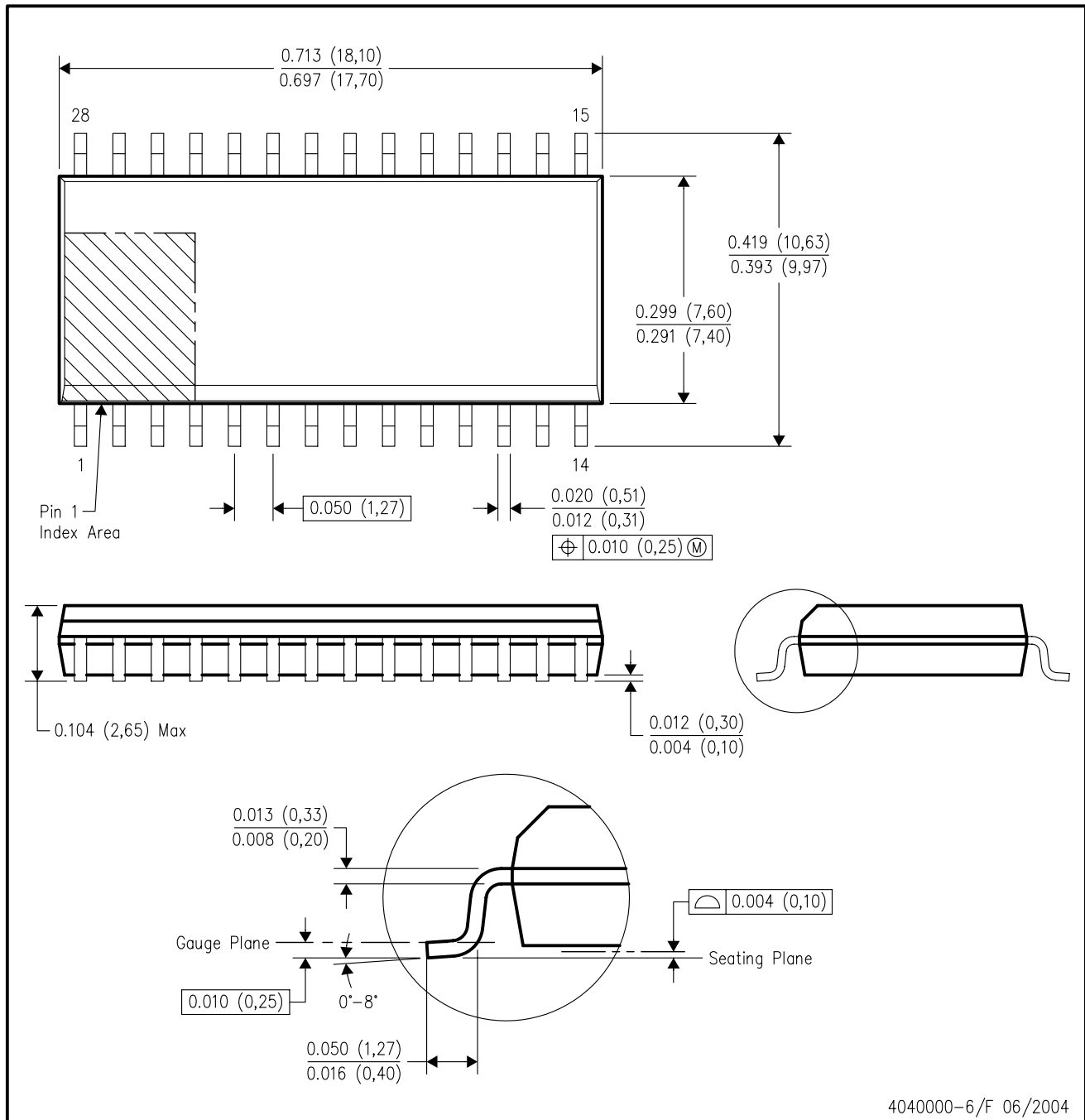

4040000-6/F 06/2004

- NOTES:
- A. All linear dimensions are in inches (millimeters).
  - B. This drawing is subject to change without notice.
  - C. Body dimensions do not include mold flash or protrusion not to exceed 0.006 (0,15).
  - D. Falls within JEDEC MS-013 variation AE.

DB (R-PDSO-G\*\*)

PLASTIC SMALL-OUTLINE

28 PINS SHOWN



- NOTES: A. All linear dimensions are in millimeters.  
 B. This drawing is subject to change without notice.  
 C. Body dimensions do not include mold flash or protrusion not to exceed 0,15.  
 D. Falls within JEDEC MO-150

## IMPORTANT NOTICE

Texas Instruments Incorporated and its subsidiaries (TI) reserve the right to make corrections, modifications, enhancements, improvements, and other changes to its products and services at any time and to discontinue any product or service without notice. Customers should obtain the latest relevant information before placing orders and should verify that such information is current and complete. All products are sold subject to TI's terms and conditions of sale supplied at the time of order acknowledgment.

TI warrants performance of its hardware products to the specifications applicable at the time of sale in accordance with TI's standard warranty. Testing and other quality control techniques are used to the extent TI deems necessary to support this warranty. Except where mandated by government requirements, testing of all parameters of each product is not necessarily performed.

TI assumes no liability for applications assistance or customer product design. Customers are responsible for their products and applications using TI components. To minimize the risks associated with customer products and applications, customers should provide adequate design and operating safeguards.

TI does not warrant or represent that any license, either express or implied, is granted under any TI patent right, copyright, mask work right, or other TI intellectual property right relating to any combination, machine, or process in which TI products or services are used. Information published by TI regarding third-party products or services does not constitute a license from TI to use such products or services or a warranty or endorsement thereof. Use of such information may require a license from a third party under the patents or other intellectual property of the third party, or a license from TI under the patents or other intellectual property of TI.

Reproduction of information in TI data books or data sheets is permissible only if reproduction is without alteration and is accompanied by all associated warranties, conditions, limitations, and notices. Reproduction of this information with alteration is an unfair and deceptive business practice. TI is not responsible or liable for such altered documentation.

Resale of TI products or services with statements different from or beyond the parameters stated by TI for that product or service voids all express and any implied warranties for the associated TI product or service and is an unfair and deceptive business practice. TI is not responsible or liable for any such statements.

TI products are not authorized for use in safety-critical applications (such as life support) where a failure of the TI product would reasonably be expected to cause severe personal injury or death, unless officers of the parties have executed an agreement specifically governing such use. Buyers represent that they have all necessary expertise in the safety and regulatory ramifications of their applications, and acknowledge and agree that they are solely responsible for all legal, regulatory and safety-related requirements concerning their products and any use of TI products in such safety-critical applications, notwithstanding any applications-related information or support that may be provided by TI. Further, Buyers must fully indemnify TI and its representatives against any damages arising out of the use of TI products in such safety-critical applications.

TI products are neither designed nor intended for use in military/aerospace applications or environments unless the TI products are specifically designated by TI as military-grade or "enhanced plastic." Only products designated by TI as military-grade meet military specifications. Buyers acknowledge and agree that any such use of TI products which TI has not designated as military-grade is solely at the Buyer's risk, and that they are solely responsible for compliance with all legal and regulatory requirements in connection with such use.

TI products are neither designed nor intended for use in automotive applications or environments unless the specific TI products are designated by TI as compliant with ISO/TS 16949 requirements. Buyers acknowledge and agree that, if they use any non-designated products in automotive applications, TI will not be responsible for any failure to meet such requirements.

Following are URLs where you can obtain information on other Texas Instruments products and application solutions:

<b>Products</b>		<b>Applications</b>	
Amplifiers	<a href="http://amplifier.ti.com">amplifier.ti.com</a>	Audio	<a href="http://www.ti.com/audio">www.ti.com/audio</a>
Data Converters	<a href="http://dataconverter.ti.com">dataconverter.ti.com</a>	Automotive	<a href="http://www.ti.com/automotive">www.ti.com/automotive</a>
DSP	<a href="http://dsp.ti.com">dsp.ti.com</a>	Broadband	<a href="http://www.ti.com/broadband">www.ti.com/broadband</a>
Interface	<a href="http://interface.ti.com">interface.ti.com</a>	Digital Control	<a href="http://www.ti.com/digitalcontrol">www.ti.com/digitalcontrol</a>
Logic	<a href="http://logic.ti.com">logic.ti.com</a>	Military	<a href="http://www.ti.com/military">www.ti.com/military</a>
Power Mgmt	<a href="http://power.ti.com">power.ti.com</a>	Optical Networking	<a href="http://www.ti.com/opticalnetwork">www.ti.com/opticalnetwork</a>
Microcontrollers	<a href="http://microcontroller.ti.com">microcontroller.ti.com</a>	Security	<a href="http://www.ti.com/security">www.ti.com/security</a>
RFID	<a href="http://www.ti-rfid.com">www.ti-rfid.com</a>	Telephony	<a href="http://www.ti.com/telephony">www.ti.com/telephony</a>
Low Power Wireless	<a href="http://www.ti.com/lpw">www.ti.com/lpw</a>	Video & Imaging	<a href="http://www.ti.com/video">www.ti.com/video</a>
		Wireless	<a href="http://www.ti.com/wireless">www.ti.com/wireless</a>

Mailing Address: Texas Instruments, Post Office Box 655303, Dallas, Texas 75265  
Copyright © 2007, Texas Instruments Incorporated