



# High-Current VCOM Drive Buffer

**MAX1886**

## General Description

The MAX1886 is a high-current operational transconductance amplifier. The MAX1886 is ideal for driving the backplane of an active matrix, dot inversion thin film transistor (TFT) liquid crystal display (LCD). The MAX1886's high >500mA peak-current drive capability provides fast response to pulsed load conditions. The MAX1886 is stable from 0.47μF to an unlimited amount of output capacitance.

The MAX1886 is available in the low-profile (1.1mm max) 5-pin Thin SOT23 package and fully specified over the -40°C to +85°C extended temperature range.

## Features

- ◆ Stable with 0.47μF to Unlimited Amount of Output Capacitance
- ◆ Over 500mA Peak Drive Current
- ◆ Excellent Settling Characteristics with Capacitive Load
- ◆ +4.5V to +13V Input Supply
- ◆ 0.45mA Quiescent Current
- ◆ Thermal Fault Protection
- ◆ Thin SOT23-5 Package (1.1mm max)

## Applications

Notebook LCD Panels  
Monitor LCD Panels

## Ordering Information

PART	TEMP. RANGE	PIN-PACKAGE	TOP MARK
MAX1886EZK	-40°C to +85°C	5 Thin SOT23-5*	ADQL

\*Requires a special solder temperature profile described in the Absolute Maximum Ratings section.

## Typical Operating Circuit

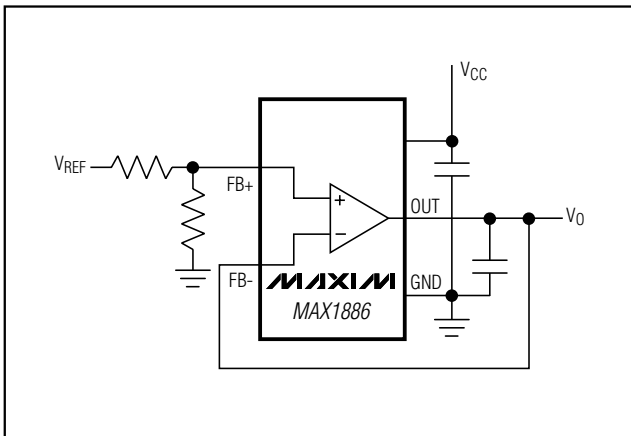

## Pin Configuration

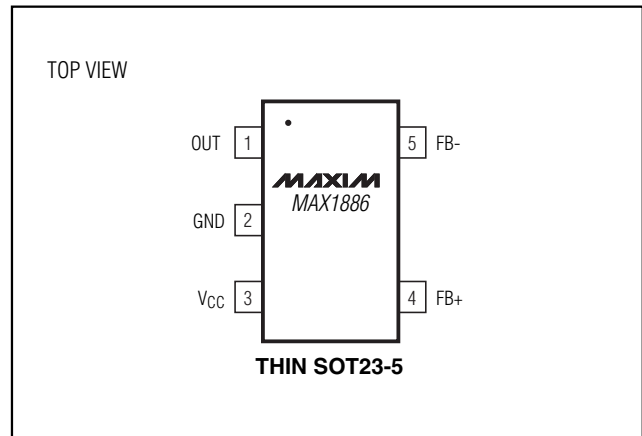

# High-Current VCOM Drive Buffer

## ABSOLUTE MAXIMUM RATINGS

V<sub>CC</sub> to GND .....-0.3V to +14V  
 FB-, FB+, OUT to GND .....-0.3V to (V<sub>CC</sub> + 0.3V)  
 Continuous Power Dissipation (T<sub>A</sub> = +70°C)  
 5-Pin Thin SOT23 (derate 7.1mW/°C above +70°C) .....727mW

Operating Temperature Range .....-40°C to +85°C  
 Junction Temperature .....+150°C  
 Storage Temperature Range .....-65°C to +150°C

*This device is constructed using a unique set of packaging techniques that impose a limit on the thermal profile the device can be exposed to during board level solder attach and rework. Maxim recommends the use of the solder profiles recommended in the industry-standard specification, JEDEC 020A, paragraph 7.6, Table 3 for IR/VPR and convection reflow processes. Preheating, per this standard, is required. Hand or wave soldering is not recommended.*

*Stresses beyond those listed under "Absolute Maximum Ratings" may cause permanent damage to the device. These are stress ratings only, and functional operation of the device at these or any other conditions beyond those indicated in the operational sections of the specifications is not implied. Exposure to absolute maximum rating conditions for extended periods may affect device reliability.*

## ELECTRICAL CHARACTERISTICS

(V<sub>CC</sub> = 10V, FB- = OUT, V<sub>FB+</sub> = 5V, C<sub>OUT</sub> = 0.47µF, T<sub>A</sub> = -40°C to +85°C, unless otherwise noted. Typical values are at T<sub>A</sub> = +25°C.)  
 (Note 1)

PARAMETER	SYMBOL	CONDITIONS	MIN	TYP	MAX	UNITS
V <sub>CC</sub> Input Supply Range	V <sub>CC</sub>		4.5		13	V
V <sub>CC</sub> Supply Current	I <sub>CC</sub>			450	900	µA
Input Offset Voltage	V <sub>OS</sub>	V <sub>FB+</sub> = +5V, no load	-5		5	mV
Input Bias Current	I <sub>BIAS</sub>	+1.2V < V <sub>CM</sub> < +8.8V	-100		100	nA
Input Offset Current	I <sub>OS</sub>		-100		100	nA
Common-Mode Input Range	V <sub>CM</sub>	V <sub>OS</sub>   < 10mV over CMR	1.2		V <sub>CC</sub> - 1.2V	V
Power-Supply Rejection Ratio	PSRR	+4.5V < V <sub>CC</sub> < +13V, V <sub>FB+</sub> = +2.25V	70			dB
Common-Mode Rejection Ratio	CMRR	+1.2V < V <sub>CM</sub> < +8.8V	70			
Gain-Bandwidth Product	GBW	Small signal		1/6πC <sub>L</sub>		Hz
Transconductance	g <sub>m</sub>	Small signal (±1mV overdrive)		0.3		S
		Large signal (±30mV overdrive)		10		
Output Current Drive	I <sub>OUT</sub>	±100mV overdrive, V <sub>OUT</sub> = 3V or 7V	T <sub>A</sub> = -40°C to +85°C	±175	±550	mA
			T <sub>A</sub> = 0°C to +85°C	±250		
Thermal Shutdown				170		°C
Thermal Shutdown Hysteresis				15		°C

**Note 1:** The MAX1886 is 100% production tested at T<sub>A</sub> = +25°C. Specifications over temperature are guaranteed by design.

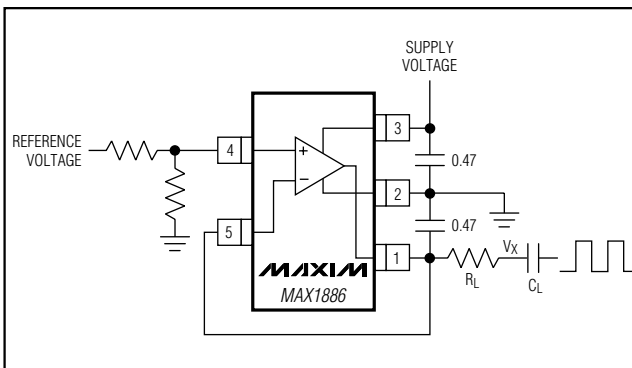

Figure 1. Load Transient Test Circuit

# High-Current VCOM Drive Buffer

MAX1886

## Typical Operating Characteristics

( $V_{CC} = 10V$ ,  $C_{OUT} = 1\mu F$ ,  $V_{CM} = 5V$ ,  $T_A = +25^\circ C$ , unless otherwise noted.)

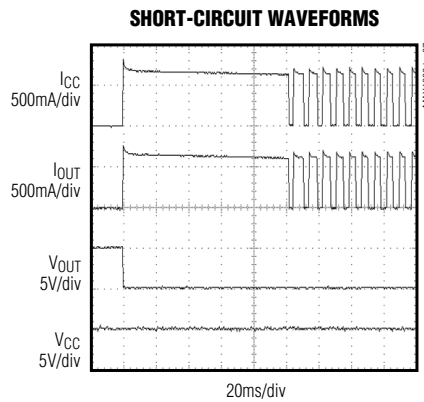
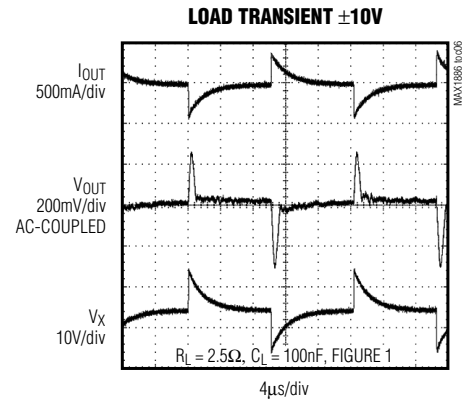
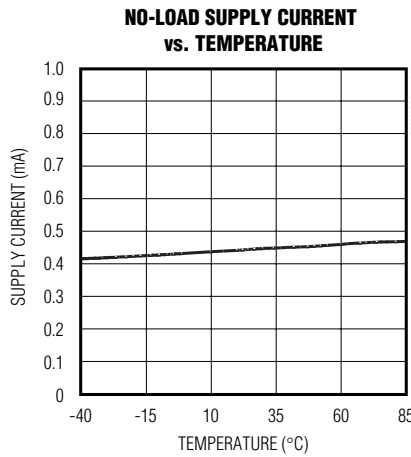
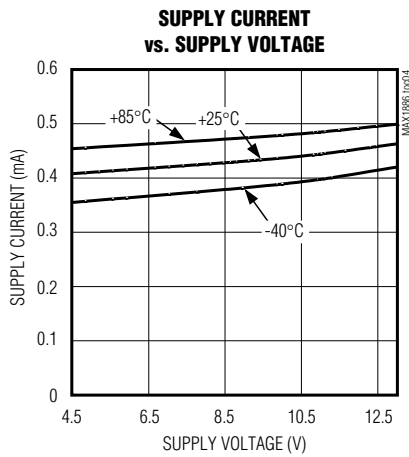
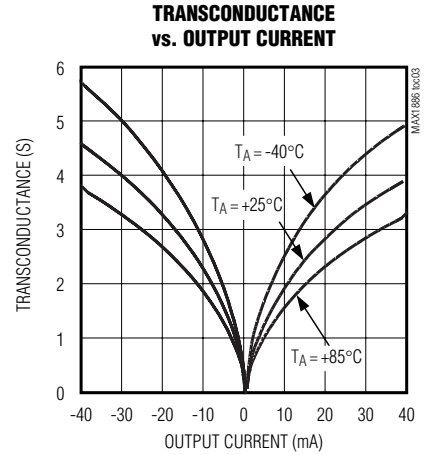
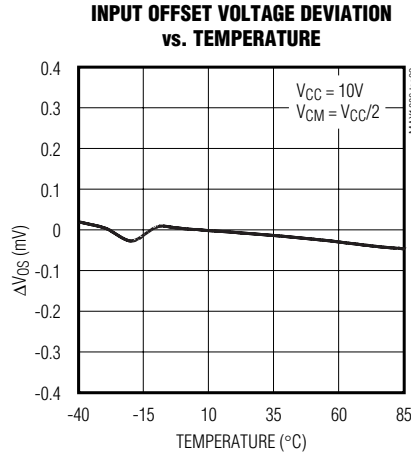
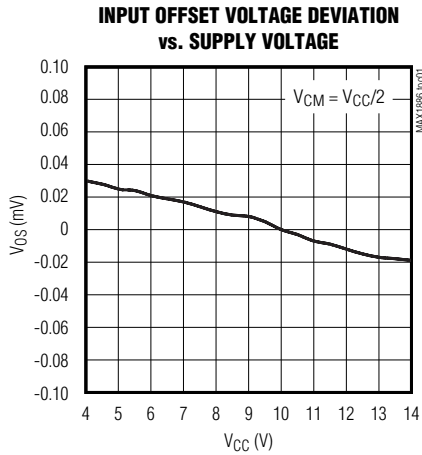

# High-Current VCOM Drive Buffer

## Typical Operating Characteristics (continued)

( $V_{CC} = 10V$ ,  $C_{OUT} = 1\mu F$ ,  $V_{CM} = 5V$ ,  $T_A = +25^\circ C$ , unless otherwise noted.)

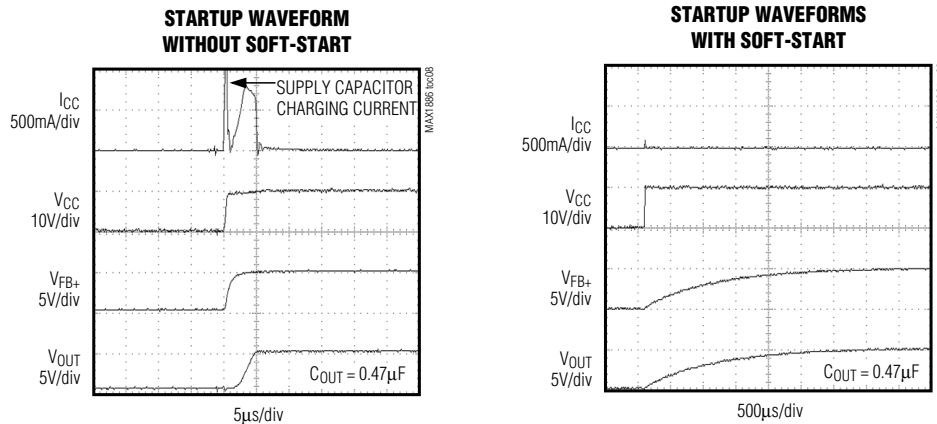

## Pin Description

PIN	NAME	DESCRIPTION
1	OUT	Output of Buffer Amplifier. Requires a minimum 0.47µF ceramic filter capacitor to GND. Place the capacitor close to OUT.
2	GND	Ground
3	VCC	Voltage-Supply Input. Bypass to GND with a 0.47µF capacitor close to the pin. Use the output capacitor of the preceding voltage regulator as the additional filter capacitor.
4	FB+	Noninverting Input to Buffer Amplifier
5	FB-	Inverting Input to Buffer Amplifier. Feedback must be taken from the output filter capacitor terminal.

## Detailed Description

The MAX1886 operational transconductance amplifier (OTA) provides high-current output that is ideal for driving capacitive loads such as the backplane of a TFT LCD panel. The positive feedback input, FB+, allows common-mode biasing to mid-supply, or other VCOM voltage.

The MAX1886 unity-gain bandwidth is  $GBW = g_m/C_{OUT}$  where  $g_m$  is the amplifier's transconductance. Transconductance is the ratio of the output current to the input voltage. The gain of the amplifier is dependent upon the load. The MAX1886 requires only a small 0.47µF ceramic output capacitor for stability. The bandwidth is inversely proportional to the output capacitor, so large capacitive loads improve stability; however, lower bandwidth decreases the buffer's transient response time. To improve the transient response

times, the MAX1886's transconductance increases as the output current increases (see *Typical Operating Characteristics*).

## Applications Information

### Output Filter Capacitor

The MAX1886 requires a minimum of 0.47µF output capacitance placed close to OUT. To ensure buffer stability, the output capacitor ESR must be 50mΩ or lower. Ceramic capacitors are an excellent choice.

### Input Bypass Capacitor

The MAX1886 requires a 0.47µF input bypass capacitor (C2) close to the VCC supply input (see Figure 2). Place the MAX1886 close to the preceding voltage regulator output capacitor so that the MAX1886 shares the same capacitor (C1). Minimize trace length and use wide

# High-Current VCOM Drive Buffer

MAX1886

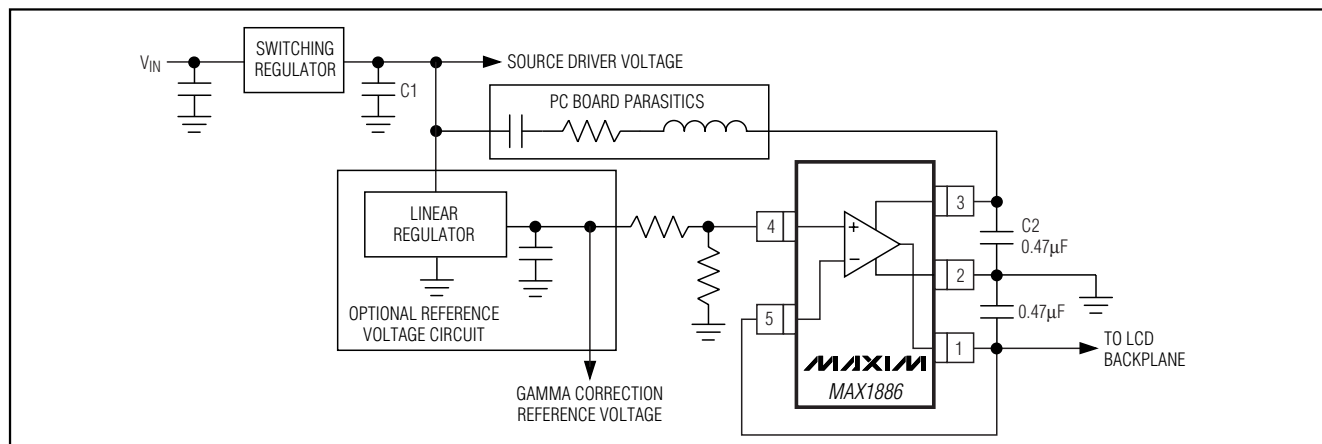

Figure 2. Typical TFT LCD Backplane Drive Circuit

traces between the voltage regulator output and the MAX1886 VCC input to reduce PC board parasitics (inductance, resistance, and capacitance), which can cause undesired ringing.

## Voltage Reference

The reference voltage for the MAX1886 input can be produced using the output of a linear regulator. The linear regulator will reject the ripple voltage produced by the source drivers (see Figure 2). The output of this linear regulator can also be used for the gamma correction reference voltage.

## Chip Information

TRANSISTOR COUNT: 121

PROCESS: BiCMOS



# High-Current VCOM Drive Buffer

## Package Information (continued)

**MAX1886**

### NOTES:

1. ALL DIMENSIONS ARE IN MILLIMETERS.
2. "D" AND "E1" ARE REFERENCE DATUM AND DO NOT INCLUDE MOLD FLASH OR PROTRUSIONS, AND ARE MEASURED AT THE BOTTOM PARTING LINE. MOLD FLASH OR PROTRUSION SHALL NOT EXCEED 0.15mm ON "D" AND 0.25mm ON "E" PER SIDE.
3. THE LEAD WIDTH DIMENSION DOES NOT INCLUDE DAMBAR PROTRUSION. ALLOWABLE DAMBAR PROTRUSION SHALL BE 0.07mm TOTAL IN EXCESS OF THE LEAD WIDTH DIMENSION AT MAXIMUM MATERIAL CONDITION.
4. DATUM PLANE "H" LOCATED AT MOLD PARTING LINE AND COINCIDENT WITH LEAD, WHERE LEAD EXITS PLASTIC BODY AT THE BOTTOM OF PARTING LINE.
5. THE LEAD TIPS MUST LINE WITHIN A SPECIFIED TOLERANCE ZONE. THIS TOLERANCE ZONE IS DEFINED BY TWO PARALLEL LINES. ONE PLANE IS THE SEATING PLANE, DATUM [-C-]; AND THE OTHER PLANE IS AT THE SPECIFIED DISTANCE FROM [-C-] IN THE DIRECTION INDICATED. FORMED LEADS SHALL BE PLANAR WITH RESPECT TO ONE ANOTHER WITH 0.10mm AT SEATING PLANE.
6. THIS PART IS COMPLIANT WITH JEDEC SPECIFICATION MO-193 EXCEPT FOR THE "e" DIMENSION WHICH IS 0.95mm INSTEAD OF 1.00mm. THIS PART IS IN FULL COMPLIANCE TO EIAJ SPECIFICATION SC-74.

SYMBOLS			
	MIN	NOM	MAX
A	-	-	1.10
A1	0.05	0.075	0.10
A2	0.85	0.88	0.90
A3	0.50 BSC		
b	0.30	-	0.45
b1	0.25	0.35	0.40
c	0.15	-	0.20
c1	0.12	0.127	0.15
D	2.80	2.90	3.00
E	2.75 BSC		
E1	1.55	1.60	1.65
L	0.30	0.40	0.50
e1	1.90 BSC		
e	0.95 BSC		
OC	0°	4°	8°
aaa	0.20		

<b>MAXIM</b>			
<small>PROPRIETARY INFORMATION</small>			
<small>TITLE: PACKAGE OUTLINE, 5 LEAD THIN SOT23, ( LOW PROFILE )</small>			
<small>APPROVAL</small>	<small>DOCUMENT CONTROL NO.</small> 21-0113	<small>REV</small> B	<small>2/2</small>

Maxim cannot assume responsibility for use of any circuitry other than circuitry entirely embodied in a Maxim product. No circuit patent licenses are implied. Maxim reserves the right to change the circuitry and specifications without notice at any time.

**Maxim Integrated Products, 120 San Gabriel Drive, Sunnyvale, CA 94086 408-737-7600** \_\_\_\_\_ **7**