



Dual USB Switch with Fault Blanking

MAX1812

General Description

The MAX1812 is a dual current-limited switch specifically made for USB applications. Each channel is guaranteed to supply 500mA and meets USB specifications. The MAX1812's low quiescent supply current (45 μ A) and shutdown current (3 μ A) conserve battery power in portable applications.

The MAX1812 has multiple safety features to ensure that the USB port is protected. Built-in thermal-overload protection limits power dissipation and junction temperature. The device also has accurate internal current-limiting circuitry to protect the input supply against both overload and short-circuit conditions. Independent fault signals (FAULTA and FAULTB) notify the microprocessor when a thermal-overload, current limit, undervoltage lockout, or short-circuit fault occurs. A 20ms fault-blanking feature enables the circuit to ignore momentary faults, such as those caused when hot-swapping a capacitive load, thereby preventing false alarms to the host system.

The MAX1812 is available in a space-saving 10-pin μ MAX package. For single versions of this device, refer to the MAX1693, MAX1694, and MAX1607 data sheets.

Applications

- USB Ports
- USB Hubs
- Notebook Computers
- Desktop Computers
- PDA's and Palmtop Computers
- Docking Stations

Typical Operating Circuit

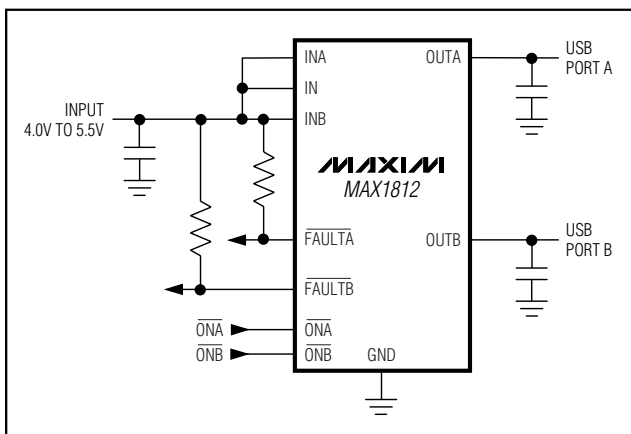

Features

- ◆ Dual USB Switch in Tiny 10-Pin μ MAX Package
- ◆ Guaranteed 500mA Load per Channel
- ◆ Built-In 20ms Fault Blanking
- ◆ Compliant to USB Specifications
- ◆ +4.0V to +5.5V Input Voltage Range
- ◆ 45 μ A Quiescent Current
- ◆ 3 μ A Shutdown Current
- ◆ Independent Shutdown Control
- ◆ Independent FAULT Indicator Outputs
- ◆ Thermal-Overload Protection
- ◆ UL Listing Pending

Ordering Information

PART	TEMP. RANGE	PIN-PACKAGE
MAX1812EUB	-40°C to +85°C	10 μ MAX

Pin Configuration

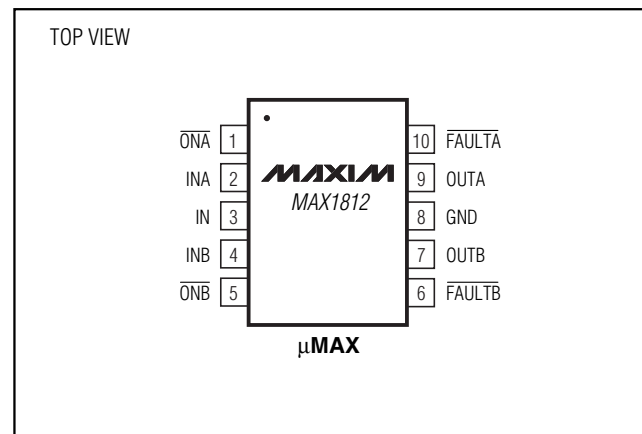

Dual USB Switch with Fault Blanking

ABSOLUTE MAXIMUM RATINGS

IN, INA, INB, $\overline{\text{ON}}_A$, $\overline{\text{ON}}_B$, OUTA, OUTB to GND -0.3V to +6V
 FAULTA, FAULTB to GND -0.3V to ($V_{IN_} + 0.3V$)
 INA, IN to OUTA; INB, IN to OUTB -0.3V to +6V
 OUTA, OUTB Maximum Continuous Switch Current
 (per channel, internally limited) 1.2A
 FAULTA, FAULTB Current 20mA

Continuous Power Dissipation ($T_A = +70^\circ\text{C}$)
 10-Pin μMAX (derate 5.6mW/ $^\circ\text{C}$ above $+70^\circ\text{C}$) 444mW
 Operating Temperature Range -40°C to $+85^\circ\text{C}$
 Junction Temperature $+150^\circ\text{C}$
 Storage Temperature Range -65°C to $+150^\circ\text{C}$
 Lead Temperature (soldering, 10s) $+300^\circ\text{C}$

Stresses beyond those listed under "Absolute Maximum Ratings" may cause permanent damage to the device. These are stress ratings only, and functional operation of the device at these or any other conditions beyond those indicated in the operational sections of the specifications is not implied. Exposure to absolute maximum rating conditions for extended periods may affect device reliability.

ELECTRICAL CHARACTERISTICS

($V_{IN} = V_{INA} = V_{INB} = 5V$, $T_A = -40^\circ\text{C}$ to $+85^\circ\text{C}$, unless otherwise noted. Typical values are at $T_A = +25^\circ\text{C}$) (Note 1)

PARAMETER	SYMBOL	CONDITIONS	MIN	TYP	MAX	UNITS	
Supply Voltage Range			4.0		5.5	V	
Switch On-Resistance	R_{ON}	$T_A = +25^\circ\text{C}$, each switch		75	105	m Ω	
		$T_A = -40^\circ\text{C}$ to $+85^\circ\text{C}$, each switch			135		
Standby Supply Current		Both switches disabled		3	10	μA	
Quiescent Supply Current		Both switches enabled, $I_{OUTA} = I_{OUTB} = 0$		45	100	μA	
OUT_ Leakage Current		Switches disabled, $V_{OUTA} = V_{OUTB} = 0$, $T_A = +25^\circ\text{C}$		0.002	1	μA	
		Switches disabled, $V_{OUTA} = V_{OUTB} = 0$, $T_A = -40^\circ\text{C}$ to 85°C			10		
Undervoltage Lockout Threshold	UVLO	Rising edge, 3% hysteresis	3.0	3.4	3.8	V	
Continuous Load Current			500			mA	
Continuous Current Limit	ILIM	$V_{IN_} - V_{OUT_} = 0.5V$	0.6	0.9	1.2	A	
Short-Circuit Current Limit	ISHORT	$V_{OUT_} = 0$ (I_{OUT} pulsing)		0.8	1.2	1.6	A(peak)
					0.35		ARMS
Short-Circuit Detect Threshold		(Note 2)		1		V	
Continuous Current-Limit Blanking Timeout Period		From continuous current-limit condition to $\overline{\text{FAULT}}_-$ assertion	10	20	35	ms	
Short-Circuit Blanking Timeout Period		From short-circuit current-limit condition to $\overline{\text{FAULT}}_-$ assertion	7.5	18	35	ms	
Turn-On Delay		$R_{OUT} = 10\Omega$, $C_{OUT} = 1\mu\text{F}$ does not include rise time (from $\overline{\text{ON}}_-$ to 10% of V_{OUT})	0.5	1.2	4.0	ms	
Output Rise Time		$R_{OUT} = 10\Omega$, $C_{OUT} = 1\mu\text{F}$, from 10% to 90% of V_{OUT}		2.5		ms	
Turn-Off Delay from ON		$R_{OUT} = 10\Omega$, $C_{OUT} = 1\mu\text{F}$ does not include fall time (from $\overline{\text{ON}}_-$ to 90% of V_{OUT})		0.8	3	ms	
Output Fall Time		$C_{OUT} = 1\mu\text{F}$, $R_{OUT} = 10\Omega$, from 90% to 10% of V_{OUT}		2.5		ms	
Thermal Shutdown Threshold		15°C hysteresis		160		$^\circ\text{C}$	

Dual USB Switch with Fault Blanking

MAX1812

ELECTRICAL CHARACTERISTICS (continued)

($V_{IN} = V_{INA} = V_{INB} = 5V$, $T_A = -40^{\circ}C$ to $+85^{\circ}C$, unless otherwise noted. Typical values are at $T_A = +25^{\circ}C$.) (Note 1)

PARAMETER	SYMBOL	CONDITIONS	MIN	TYP	MAX	UNITS
Logic Input High Voltage		$V_{IN_} = +4V$ to $+5.5V$	2			V
Logic Input Low Voltage		$V_{IN_} = +4V$ to $+5.5V$			0.8	V
Logic Input Current		$\overline{V_{ON_}} = 0$ or $V_{IN_}$	-1		1	μA
$\overline{FAULT_}$ Output Low Voltage		$I_{SINK} = 1mA$, $V_{IN_} = 4V$			0.4	V
$\overline{FAULT_}$ Output High Leakage Current		$V_{IN_} = V_{\overline{FAULT_}} = 5.5V$			1	μA

Note 1: Specifications to $-40^{\circ}C$ are guaranteed by design, not production tested.

Note 2: The output voltage at which the device transitions from short-circuit current limit to continuous current limit.

Typical Operating Characteristics

($V_{IN} = V_{INA} = V_{INB} = 5V$, Circuit of Figure 2, $T_A = +25^{\circ}C$, unless otherwise noted.)

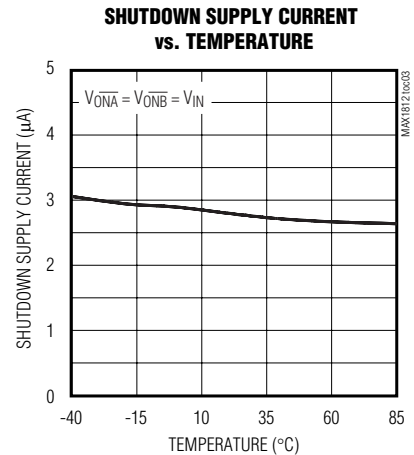
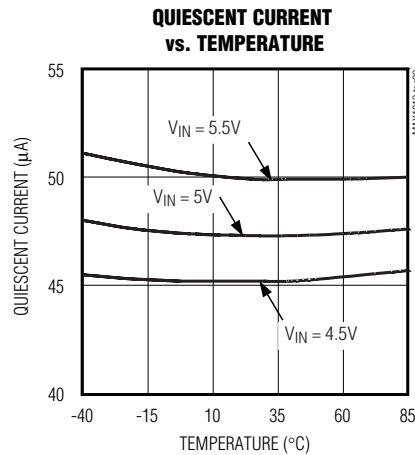
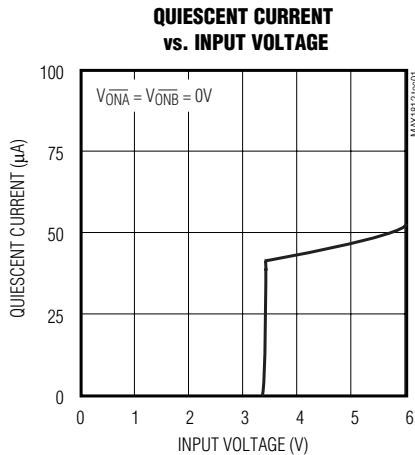

Dual USB Switch with Fault Blanking

Typical Operating Characteristics

($V_{IN} = V_{INA} = V_{INB} = 5V$, Circuit of Figure 2, $T_A = +25^\circ C$, unless otherwise noted.)

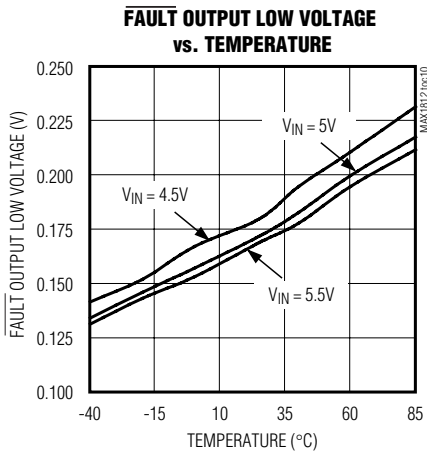
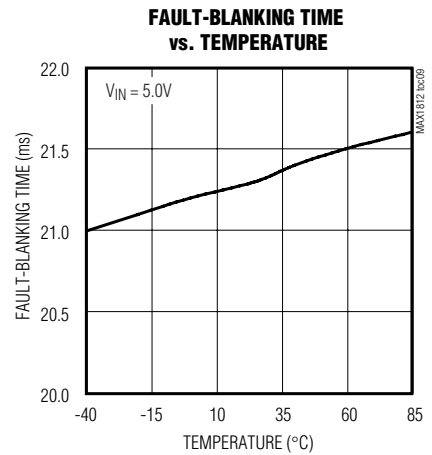
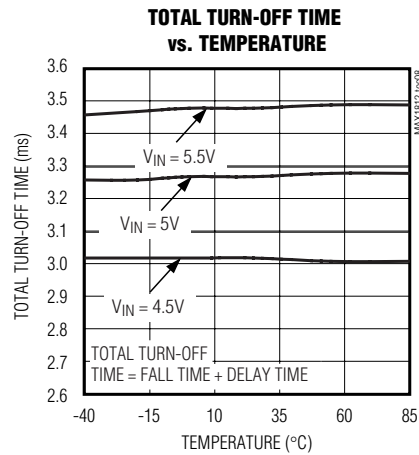
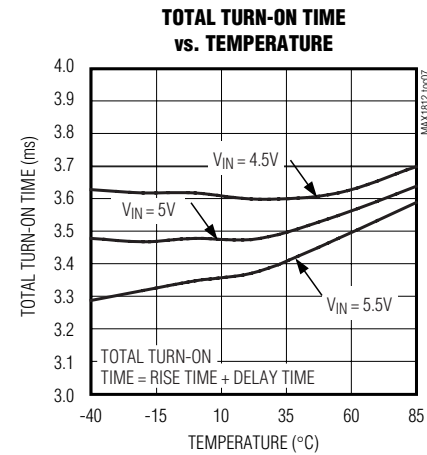
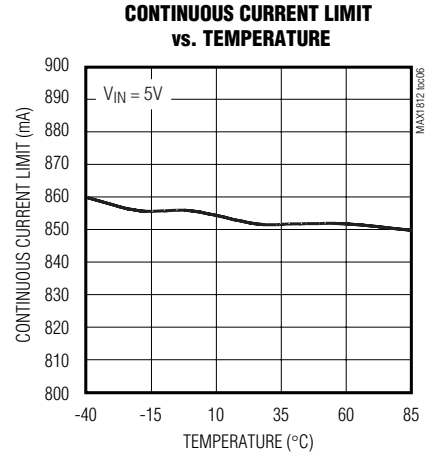
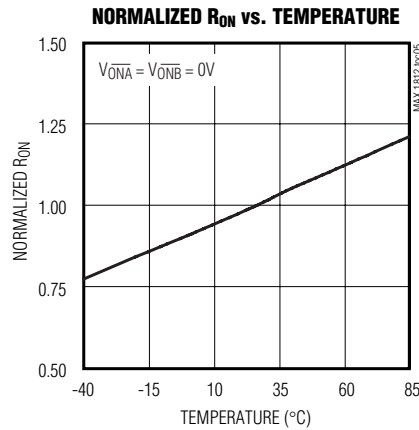
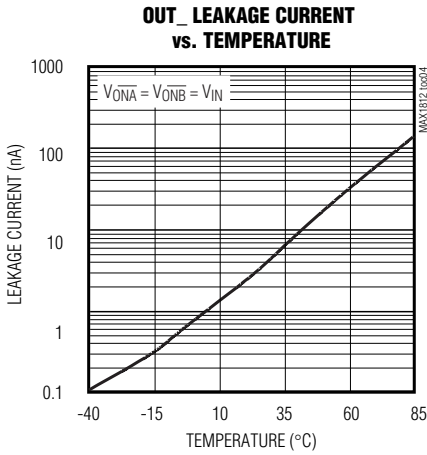

OVERLOAD RESPONSE INTO 2.5Ω LOAD

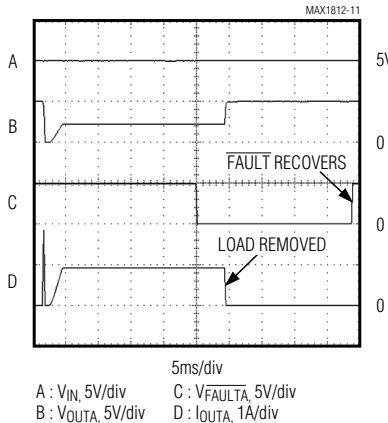

OVERLOAD RESPONSE INTO 2.5Ω LOAD (EXPANDED TIME SCALE)

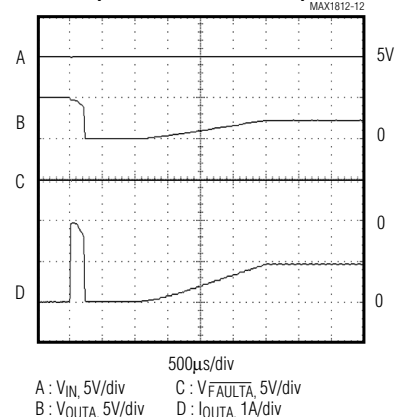

Dual USB Switch with Fault Blanking

MAX1812

Typical Operating Characteristics (continued)

($V_{IN} = V_{INA} = V_{INB} = 5V$, Circuit of Figure 2, $T_A = +25^\circ C$, unless otherwise noted.)

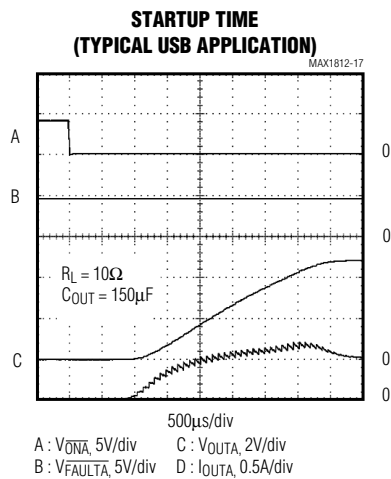
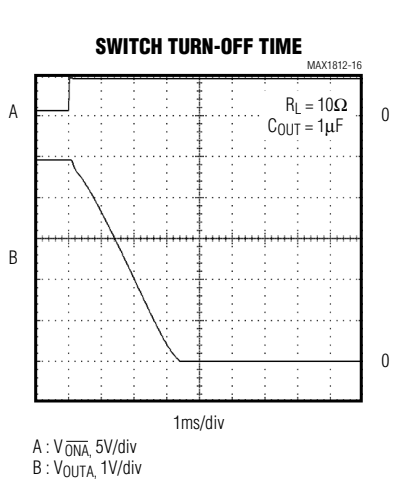
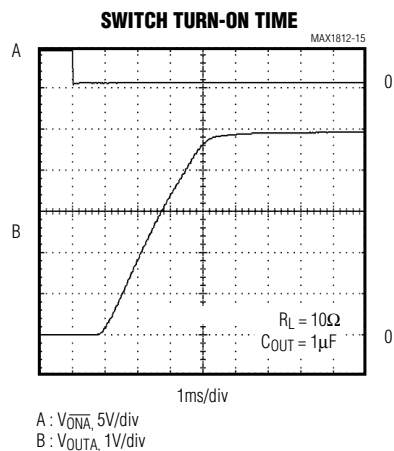
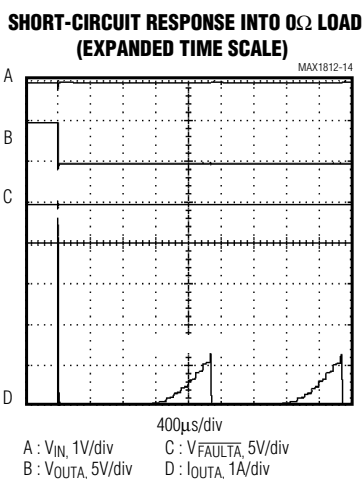
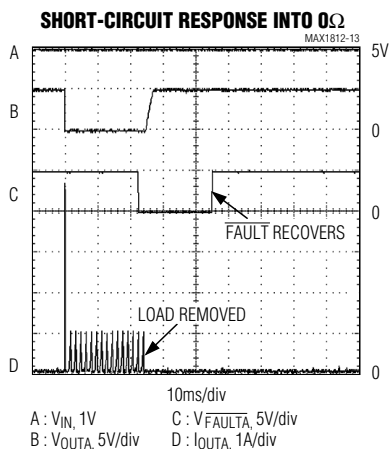

Dual USB Switch with Fault Blanking

Pin Description

PIN	NAME	FUNCTION
1	$\overline{\text{ONA}}$	Control Input for Switch A. Can be driven higher than IN_- without damage. A logic low turns switch A on.
2, 3, 4	INA, IN, INB	Power Input. Connect all IN_- pins together and bypass with a 0.1 μF capacitor to ground. Load conditions may require additional bulk capacitance to prevent the input from being pulled down.
5	$\overline{\text{ONB}}$	Control Input for Switch B. Can be higher than IN_- without damage. A logic low turns switch B on.
6	$\overline{\text{FAULTB}}$	Fault Indicator Output for Switch B. This open-drain output goes low when switch B is in thermal shutdown or undervoltage lockout or in a sustained (>20ms) current-limit or short-circuit condition.
7	OUTB	Power Output for Switch B. Connect a 1 μF capacitor from OUTB to ground. Load condition may require additional bulk capacitance. See USB requirements.
8	GND	Ground
9	OUTA	Power Output for Switch A. Connect a 1 μF capacitor from OUTA to ground. Load condition may require additional bulk capacitance. See USB requirements.
10	$\overline{\text{FAULTA}}$	Fault Indicator Output for Switch A. This open-drain output goes low when switch A is in thermal shutdown or undervoltage lockout or in a sustained (>20ms) current-limit or short-circuit condition.

Detailed Description

The MAX1812 is a dual current-limited switch designed specifically for USB applications. It has two independent switches, each with its own enable control input. Each switch also has an independent error flag output to notify the USB controller when the current-limit, short-circuit, undervoltage-lockout, or thermal-shutdown threshold is reached (Figure 1).

The MAX1812 operates from a +4V to +5.5V input voltage and guarantees a minimum output current of 500mA. A built-in current-limit of 0.9A (typ) limits the current in the event of a heavy overload condition. The MAX1812 has independent thermal shutdown for each switch in the event of a prolonged overload or short-circuit condition.

Use of internal low R_{ON} NMOS switches enables the MAX1812 to fit two switches in the ultra-small 10-pin μMAX package. An internal micropower charge pump generates the high-side supply needed for driving the gates of these high-side switches. Separate current-limiting and thermal-shutdown circuits permit each switch to operate independently, improving system robustness.

Undervoltage Lockout and Input Voltage Requirements

The MAX1812 includes an undervoltage-lockout (UVLO) circuit to prevent erroneous switch operation when the input voltage goes low during startups and

brownout conditions. Operation is inhibited when $V_{\text{IN}_-} < 3.4\text{V}$.

Output Fault Protection

The MAX1812 senses the switch output voltage and selects continuous current limiting when $V_{\text{OUT}_-} > 1\text{V}$, or pulsed current limiting when $V_{\text{OUT}_-} < 1\text{V}$. When $V_{\text{OUT}_-} > 1\text{V}$, the device operates in a continuous current-limit mode, which sets the output current limit to 0.9A (typ). When $V_{\text{OUT}_-} < 1\text{V}$, the device operates in short-circuit current-limit mode. The MAX1812 pulses the output current at 400Hz to limit the output current to 0.35A (RMS).

Thermal Shutdown

The MAX1812 features independent thermal shutdown for each switch channel, allowing one switch to deliver power even if the other switch has a fault condition. When the junction temperature exceeds +160°C, the switch turns off and the $\overline{\text{FAULT}}_-$ output goes low immediately; fault blanking does not occur during thermal limit. When the junction cools by 15°C, the switch turns back on again. If the fault overload condition continues, the switch will cycle on and off, resulting in a pulsed output that saves battery power.

Fault Indicators

The MAX1812 provides an open-drain fault output ($\overline{\text{FAULT}}_-$) for each switch. For most applications, connect $\overline{\text{FAULT}}_-$ to IN_- through a 100k Ω pullup resistor.

Dual USB Switch with Fault Blanking

MAX1812

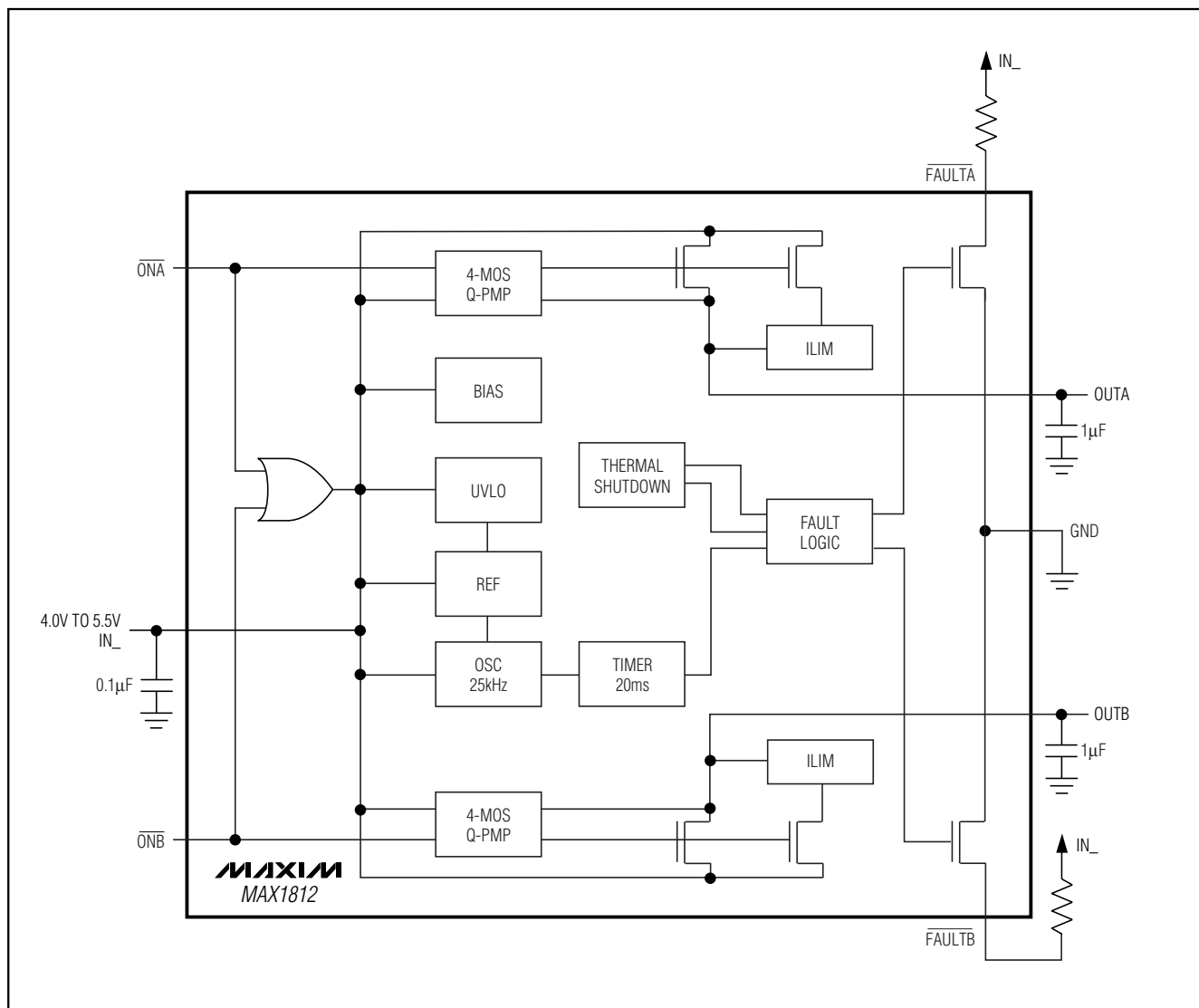

Figure 1. Functional Diagram

$\overline{\text{FAULT}}_x$ goes low when any of the following conditions occur:

- The input voltage is below the undervoltage-lockout (UVLO) threshold.
- The switch junction temperature exceeds the thermal shutdown temperature limit of +160°C.
- The switch is in current limit or short-circuit limit mode and the fault-blanking period is exceeded.

The fault indicators have a latching delay to prevent short $\overline{\text{FAULT}}_x$ pulses. After the fault-condition is removed, the $\overline{\text{FAULT}}_x$ output will deassert after a 20ms delay. Ensure that the MAX1812 has adequate input bypass capacitance to prevent glitches from triggering $\overline{\text{FAULT}}_x$ outputs. Input glitches greater than 0.2V/µs may cause spurious $\overline{\text{FAULT}}_x$ transitions.

Dual USB Switch with Fault Blanking

Table 1. MAX1812 Current Limiting and Fault Behavior

CONDITION	MAX1812 BEHAVIOR
If a short circuit is present ($V_{OUT} < 1V$)	If a short circuit is present at startup, current will ramp up to ISHORT in 2ms–3ms, and the switch will shut off. The blanking timer turns on, but \overline{FAULT}_- stays high. If a short circuit occurs during operation, current output will be pulsed at 0.35A (RMS). If ISHORT is exceeded between 15ms–20ms, then the short circuit is still present and \overline{FAULT}_- goes low at 20ms. When the short circuit is removed, the next ramped current pulse will soft-start the output. The \overline{FAULT}_- flag releases at the end of the next cycle.
If an overload current is present ($V_{OUT} > 1V$)	Current will regulate at ILIM (0.9A typ). The blanking timer turns on, but \overline{FAULT}_- stays high. Continuous current at ILIM persists until the overload is removed or a thermal fault occurs. If overcurrent is still present at 20ms, then \overline{FAULT}_- goes low. When the overcurrent condition is removed, the \overline{FAULT}_- flag releases at the end of the next cycle.
If thermal fault condition is present	\overline{FAULT}_- immediately goes low (the blanking timer does not apply to thermal faults), and the switch turns off. When thermal condition is removed, switch control returns to the current-limit loop. \overline{FAULT}_- goes high at the end of the timer period if no further thermal or current-limit faults exist.

Behavior During Current Limit and Fault Blanking

The MAX1812 limits switch current in three ways (Table 1). When \overline{ON}_- is high, the switch is off, and the residual output current is dominated by leakage. When \overline{ON}_- is low, the switch can supply a continuous output current of at least 500mA. When the output current exceeds the 0.9A (typ) threshold, the MAX1812 will limit the current, depending upon the output voltage. If $V_{OUT} > 1V$ (current-limit mode), the MAX1812 serves the switch drive so that the peak current does not exceed 1.2A (max). If $V_{OUT} < 1V$ (short-circuit mode), the MAX1812 pulses the switch drive to decrease the current to 0.35A (RMS). **Note that a thermal overload may result from either of these high-current conditions.**

The switches in the MAX1812 may enter current limit in normal operation when powering up or when driving heavy capacitive loads. To differentiate these conditions from short circuits or sustained overloads that may damage the device, the MAX1812 has an independent fault-blanking circuit in each switch. When a load transient causes the device to enter current limit, an internal counter monitors the duration of the fault. If the load fault persists beyond the 20ms fault-blanking timeout, then the switch turns off and the \overline{FAULT}_- signal asserts low. Only current-limit and short-circuit faults are blanked. Thermal overload faults and input voltage

drops below the UVLO threshold immediately cause the switch to turn off and the \overline{FAULT}_- to assert low.

Fault blanking allows the MAX1812 to handle USB loads that may not be fully compliant with the USB specifications. USB loads with additional bypass capacitance and/or large startup currents can be successfully powered even while protecting the upstream power source. If the switch is able to bring up the load within the 20ms blanking period, no fault is reported.

Applications Information

Input Power Source

The power for all control and charge-pump circuitry comes from IN, INA, and INB. All three IN_- pins must be connected together externally.

Input Capacitor

To limit the input voltage drop during momentary output short-circuit conditions, connect a capacitor from IN_- to ground. A 0.1 μ F ceramic capacitor is required for local decoupling; however, higher capacitor values will further reduce the voltage drop at the input (Figure 2). When driving inductive loads, a larger capacitance will prevent voltage spikes from exceeding the device's absolute maximum ratings.

Output Capacitor

An output capacitor helps prevent inductive parasitics from pulling OUT_- negative during turn-off. At startups,

Dual USB Switch with Fault Blanking

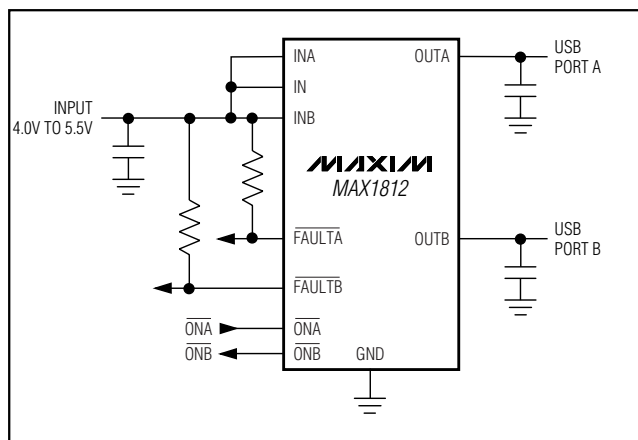

Figure 2. Typical Application Circuit

the switch pulses the output current at 0.35A RMS until the output voltage rises above 1V, then the capacitor will continue to charge at the full 0.9A current limit. There is no limit to the output capacitor size, but to prevent a startup fault assertion the capacitor must charge up within the fault-blanking delay period. Typically starting up into a 330µF or smaller capacitor will not trigger a fault output. In addition to bulk capacitance, small value (0.1µF) ceramic capacitors improve the output's resilience to electrostatic discharge (ESD).

Driving Inductive Loads

A wide variety of devices (mice, keyboards, cameras, and printers) can load the USB port. These devices commonly connect to the port with cables, which can add an inductive component to the load. This inductance can cause the output voltage at the USB port to ring during a load step. The MAX1812 is capable of driving inductive loads, but care should be taken to avoid exceeding the device's absolute maximum ratings. Usually, the load inductance is relatively small, and the MAX1812's input includes a substantial bulk capacitance from an upstream regulator as well as a local bypass, so the amount of transient overshoot is small. If the load inductance is very large, ringing may become severe, and it may be necessary to clamp the MAX1812's output below 6V and above -0.3V.

Turn-On and Turn-Off Behavior

In normal operation, the MAX1812's internal switches turn on and turn off slowly under the control of the ON_ inputs. Transition times for both edges are approximately 2ms. The slow charge-pump switch-drive minimizes load transients the upstream power source. Under thermal fault and under voltage lockout, the

power device will turn off rapidly (100ns typ) to protect the power device.

Layout and Thermal Dissipation

To optimize the switch-response time to output short-circuit conditions, it is important to keep all traces as short as possible to reduce the effect of undesirable parasitic inductance. Place input and output capacitors no more than 5mm from the package leads. All IN_ and OUT_ pins must be connected with short traces to the power bus. Wide power bus planes provide superior heat dissipation through the switch IN_ and OUT_ pins.

Under normal operating conditions, power dissipation is small and the package can conduct heat away. Calculate the maximum power dissipation for normal operation as follows:

$$P = (I_{OUT_})^2 R_{ON}$$

$$P = (0.5A)^2 \times 0.135\Omega = 34mW \text{ per switch}$$

where $I_{OUT_}$ is the maximum normal operating current, and R_{ON} is the on-resistance of the switch (135mΩ max).

The worst-case power dissipation occurs when the switch is in current limit and the output is greater than 1V. In this case, the power dissipated in each switch is the voltage drop across the switch multiplied by the current limit:

$$P = (I_{LIM}) (V_{IN} - V_{OUT})$$

For a 5V input and 1V output, the maximum power dissipation per switch is:

$$P = (1.2A) (5V - 1V) = 4.8W$$

Since the maximum package power dissipation is only 444mW, the MAX1812 die temperature will quickly exceed the thermal-shutdown threshold, and the switch output will pulse on and off. The duty cycle and period are strong functions of the ambient temperature and the PC board layout.

When the output is short circuited, current limiting activates and the power dissipated across the switch increases as does junction temperature. If the fault condition persists, the thermal-overload-protection circuitry activates (see *Thermal Shutdown*).

Chip Information

TRANSISTOR COUNT: 2739

PROCESS: BiCMOS

Dual USB Switch with Fault Blanking

Package Information

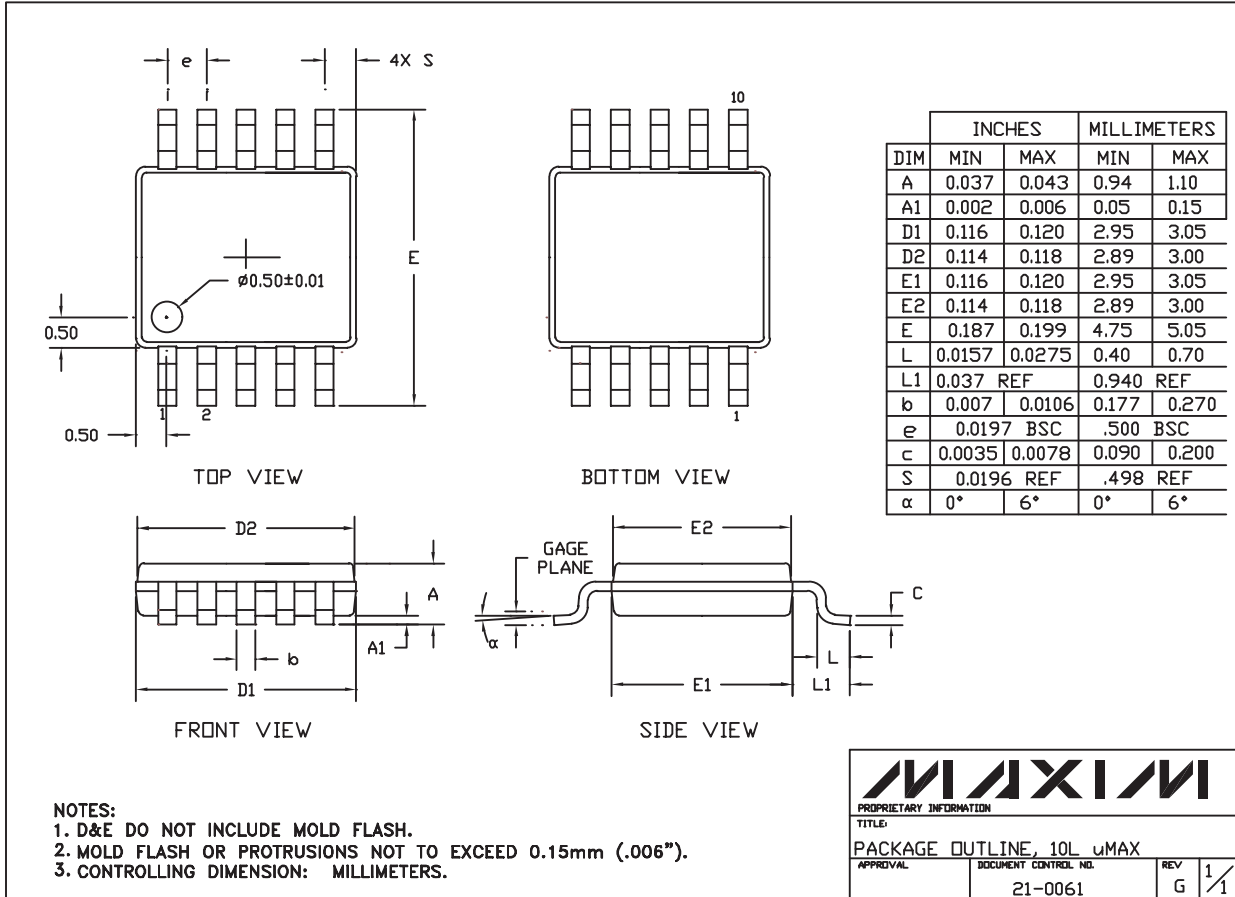

10LUMAX.EPS

Maxim cannot assume responsibility for use of any circuitry other than circuitry entirely embodied in a Maxim product. No circuit patent licenses are implied. Maxim reserves the right to change the circuitry and specifications without notice at any time.

10 Maxim Integrated Products, 120 San Gabriel Drive, Sunnyvale, CA 94086 408-737-7600