



# 125mA, Frequency-Selectable, Switched-Capacitor Voltage Converters

## General Description

The MAX1680/MAX1681 inductorless switched-capacitor voltage converters either invert an input voltage of +2.0V to +5.5V or double it while supplying up to 125mA output current. They have a selectable-frequency option that allows the use of small capacitors: 4.7 $\mu$ F (MAX1680), 1 $\mu$ F (MAX1681). With their high output current capability, these charge-pump devices are suitable replacements for inductor-based regulators, which require more expensive external components and additional board space.

The devices' equivalent output resistance (typically 3.5 $\Omega$ ) allows them to deliver as much as 125mA with only a 440mV drop. A shutdown feature reduces quiescent current to less than 1 $\mu$ A. The MAX1680/MAX1681 are available in 8-pin SO packages. For devices that deliver up to 50mA in smaller  $\mu$ MAX packages, refer to the MAX860/MAX861 data sheet.

## Applications

Local Negative Supplies  
Interface Power Supplies  
Op-Amp Power Supplies  
MOSFET Bias

## Features

- ◆ **Selectable Switching Frequencies:**  
125kHz/250kHz (MAX1680)  
500kHz/1MHz (MAX1681)
- ◆ **Allow Use of Small Capacitors**  
(1 $\mu$ F for the MAX1681)
- ◆ **125mA Output Current**
- ◆ **3.5 $\Omega$  Output Impedance**
- ◆ **1 $\mu$ A Logic-Controlled Shutdown**
- ◆ **Configurable as Voltage Inverters or Doublers**
- ◆ **+2.0V to +5.5V Input Voltage Range**
- ◆ **Available in 8-Pin SO Packages**
- ◆ **90% Efficiency**

MAX1680/MAX1681

## Ordering Information

PART	TEMP. RANGE	PIN-PACKAGE
MAX1680C/D	0°C to +70°C	Dice*
MAX1680ESA	-40°C to +85°C	8 SO
MAX1681C/D	0°C to +70°C	Dice*
MAX1681ESA	-40°C to +85°C	8 SO

\*Contact factory for dice specifications.

Pin Configuration appears at end of data sheet.

## Typical Operating Circuits

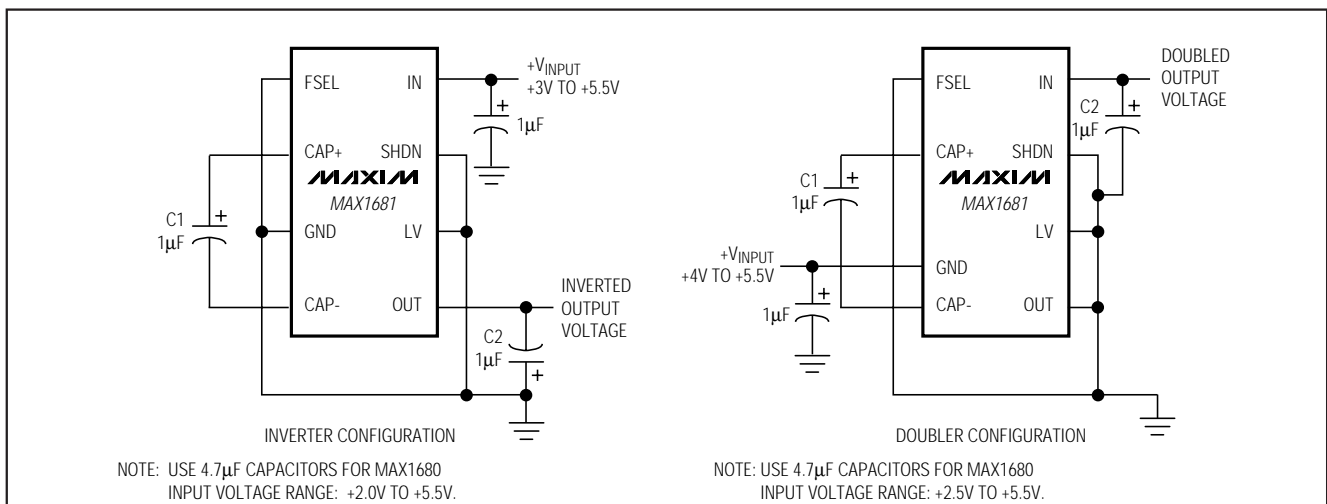

Maxim Integrated Products 1

For free samples & the latest literature: <http://www.maxim-ic.com>, or phone 1-800-998-8800.  
For small orders, phone 408-737-7600 ext. 3468.

# 125mA, Frequency-Selectable, Switched-Capacitor Voltage Converters

## ABSOLUTE MAXIMUM RATINGS

IN	-0.3V to +6V	Continuous Power Dissipation (T <sub>A</sub> = +70°C)
LV	(V <sub>OUT</sub> - 0.3V) to (V <sub>IN</sub> + 0.3V)	SO (derate 5.88mW/°C above +70°C)
CAP+	-0.3V to (V <sub>IN</sub> + 0.3V)	Operating Temperature Range
SHDN, FSEL	(V <sub>LV</sub> - 0.3V) to (V <sub>IN</sub> + 0.3V)	Junction Temperature
OUT, CAP-	-6V to 0.3V	Storage Temperature Range
Continuous Output Current	135mA	Lead Temperature (soldering, 10sec)
Output Short-Circuit Duration to GND (Note 1)	1sec	

**Note 1:** Shorting OUT to IN may damage the device and should be avoided.

Stresses beyond those listed under "Absolute Maximum Ratings" may cause permanent damage to the device. These are stress ratings only, and functional operation of the device at these or any other conditions beyond those indicated in the operational sections of the specifications is not implied. Exposure to absolute maximum rating conditions for extended periods may affect device reliability.

## ELECTRICAL CHARACTERISTICS

(Typical Operating Circuits (inverter configuration), FSEL = LV = GND, V<sub>IN</sub> = 5V, C1 = C2 = 10μF (MAX1680), C1 = C2 = 2.2μF (MAX1681), T<sub>A</sub> = 0°C to +85°C, unless otherwise noted. Typical values are at T<sub>A</sub> = +25°C.)

PARAMETER	SYMBOL	CONDITIONS		MIN	TYP	MAX	UNITS	
Input Voltage Range	V <sub>IN</sub>	Inverter configuration, R <sub>L</sub> = 1kΩ, LV = GND	MAX1680	2.0		5.5	V	
			MAX1681	3.0		5.5		
		Doubler configuration, R <sub>L</sub> = 1kΩ, LV = OUT	MAX1680	2.5		5.5		
			MAX1681	4.0		5.5		
Supply Current	I <sub>+</sub>	MAX1680	FSEL = IN (125kHz)	T <sub>A</sub> = +25°C	2.5	4.5	mA	
						5.4		
			FSEL = LV (250kHz)	T <sub>A</sub> = +25°C	5	9		
		MAX1681	FSEL = IN (500kHz)	T <sub>A</sub> = +25°C	10	18		
						21.6		
			FSEL = LV (1MHz)	T <sub>A</sub> = +25°C	20	36		
				43.2				
Output Voltage Under Load (Note 2)	V <sub>LOAD</sub>	I <sub>LOAD</sub> = 125mA		-3.75	-4.56		V	
Output Resistance (Note 2)	R <sub>OUT</sub>	FSEL = IN or LV			3.5	10	Ω	
Output Resistance to Ground in Shutdown	R <sub>OUT(SHUT)</sub>	SHDN = IN			1	5	Ω	
Shutdown Current	I <sub>+</sub> SHDN	OUT = GND, SHDN = IN				1	μA	
Input Bias Current (SHDN)	I <sub>SHDN</sub>			-1		1	μA	
Input Bias Current (FSEL)	I <sub>FSEL</sub>			-1		1	μA	
Shutdown, FSEL Thresholds	V <sub>IL</sub>	LV = GND (Note 3)				1	V	
	V <sub>IH</sub>			4				
Switching Frequency	f <sub>OSC</sub>	MAX1680	FSEL = LV	T <sub>A</sub> = +25°C	187	250	313	kHz
					157		348	
			FSEL = IN	T <sub>A</sub> = +25°C	94	125	156	
					79		174	
		MAX1681	FSEL = LV	T <sub>A</sub> = +25°C	750	1000	1250	
					570		1490	
			FSEL = IN	T <sub>A</sub> = +25°C	375	500	625	
					285		745	

# 125mA, Frequency-Selectable, Switched-Capacitor Voltage Converters

MAX1680/MAX1681

## ELECTRICAL CHARACTERISTICS (continued)

(Typical Operating Circuits (inverter configuration), FSEL = LV = GND,  $V_{IN} = 5V$ ,  $C1 = C2 = 10\mu F$  (MAX1680),  $C1 = C2 = 2.2\mu F$  (MAX1681),  $T_A = 0^\circ C$  to  $+85^\circ C$ , unless otherwise noted. Typical values are at  $T_A = +25^\circ C$ .)

PARAMETER	SYMBOL	CONDITIONS	MIN	TYP	MAX	UNITS
Power Efficiency		$R_L = 100\Omega$ to GND, FSEL = IN	MAX1680	90		%
			MAX1681	80		

## ELECTRICAL CHARACTERISTICS

(Typical Operating Circuits (inverter configuration), FSEL = LV = GND,  $V_{IN} = 5V$ ,  $C1 = C2 = 10\mu F$  (MAX1680),  $C1 = C2 = 2.2\mu F$  (MAX1681),  $T_A = -40^\circ C$  to  $+85^\circ C$ , unless otherwise noted.) (Note 4)

PARAMETER	SYMBOL	CONDITIONS	MIN	TYP	MAX	UNITS
Input Voltage Range	$V_{IN}$	Inverter configuration, $R_L = 1k\Omega$ , LV = GND	MAX1680	2.0	5.5	V
			MAX1681	3.0	5.5	
		Doubler configuration, $R_L = 1k\Omega$ , LV = OUT	MAX1680	2.5	5.5	
			MAX1681	4.0	5.5	
Supply Current	I+	MAX1680	FSEL = IN (125kHz)		5.4	mA
			FSEL = LV (250kHz)		10.8	
		MAX1681	FSEL = IN (500kHz)		21.6	
			FSEL = LV (1MHz)		43.2	
Output Voltage Under Load (Note 2)	$V_{LOAD}$	$I_{LOAD} = 125mA$	-3.75			V
Output Resistance (Note 2)	$R_{OUT}$	FSEL = IN or LV			10	$\Omega$
Output Resistance in Shutdown	$R_{OUT(SHUT)}$	SHDN = IN			5	$\Omega$
Shutdown Current	$I_{+SHDN}$	OUT = GND, SHDN = IN			1	$\mu A$
Input Bias Current (SHDN)	$I_{SHDN}$				1	$\mu A$
Input Bias Current (FSEL)	$I_{FSEL}$		-1		1	$\mu A$
Shutdown, FSEL Thresholds	$V_{IL}$	LV = GND (Note 3)	-1		1	V
	$V_{IH}$		4			
Switching Frequency	$f_{OSC}$	MAX1680	FSEL = LV	157	348	kHz
			FSEL = IN	79	174	
		MAX1681	FSEL = LV	570	1490	
			FSEL = IN	285	745	

**Note 2:** C1 and C2 are low-ESR ( $<0.2\Omega$ ) capacitors. Capacitor ESR adds to the circuit's output resistance. Using capacitors with higher ESR reduces output voltage and efficiency. The specified output resistance includes the C1 and C2  $0.2\Omega$  ESR.

**Note 3:** The typical threshold for  $V_{INPUT}$  other than +5V is  $0.35V_{INPUT}$  ( $V_{IL} = V_{IH}$ ).

**Note 4:** Specifications to  $-40^\circ C$  are guaranteed by design, not production tested.

# 125mA, Frequency-Selectable, Switched-Capacitor Voltage Converters

## Typical Operating Characteristics

(All curves generated using the inverter configuration shown in the *Typical Operating Circuits* with LV = GND, FSEL = IN or LV, C1 = C2 = 10 $\mu$ F (MAX1680), C1 = C2 = 2.2 $\mu$ F (MAX1681), and T<sub>A</sub> = +25°C, unless otherwise noted. Test results are also valid for the doubler configuration with LV = OUT and T<sub>A</sub> = +25°C.)

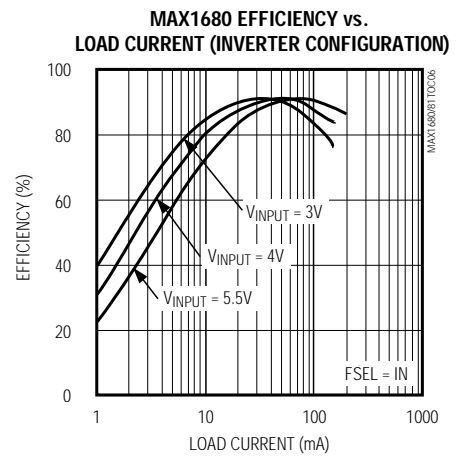
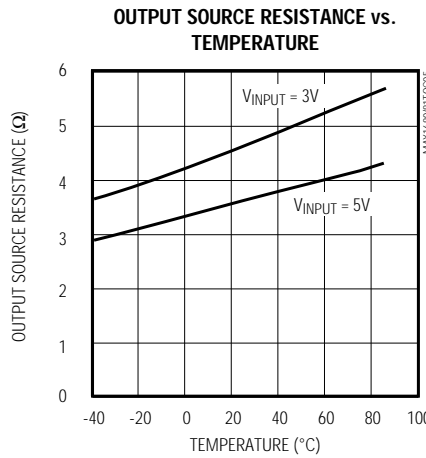
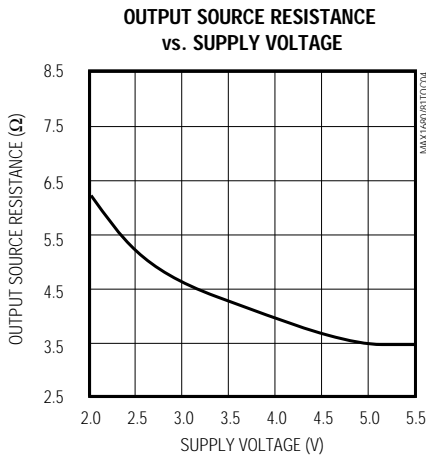
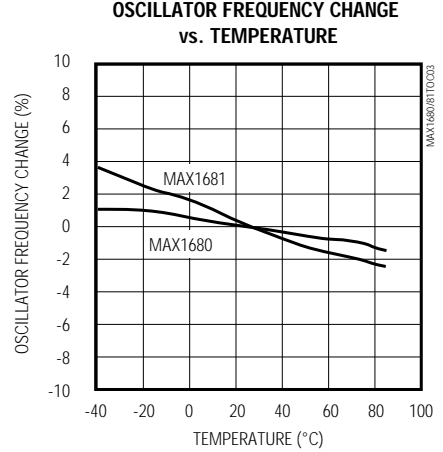
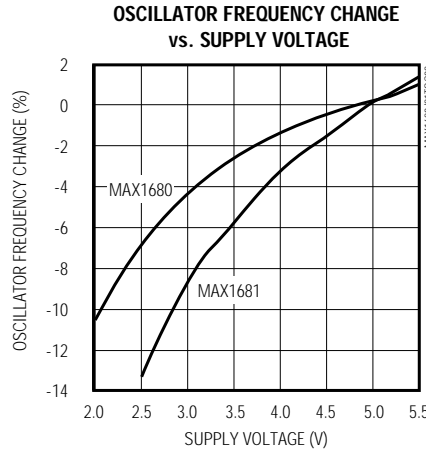
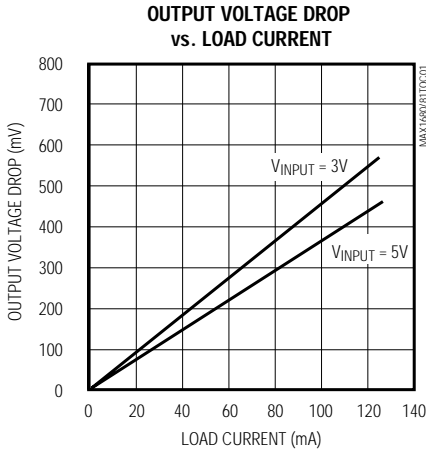

# 125mA, Frequency-Selectable, Switched-Capacitor Voltage Converters

## Typical Operating Characteristics (continued)

(All curves generated using the inverter configuration shown in the *Typical Operating Circuits* with LV = GND, FSEL = IN or LV, C1 = C2 = 10 $\mu$ F (MAX1680), C1 = C2 = 2.2 $\mu$ F (MAX1681), and T<sub>A</sub> = +25°C, unless otherwise noted. Test results are also valid for the doubler configuration with LV = OUT and T<sub>A</sub> = +25°C.)

MAX1680/MAX1681

**MAX1681 EFFICIENCY vs. LOAD CURRENT (DOUBLER CONFIGURATION)**

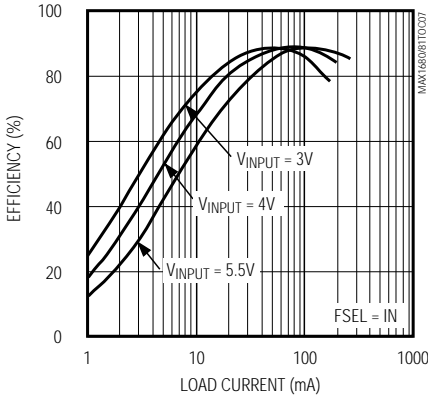

**MAX1680 SUPPLY CURRENT vs. SUPPLY VOLTAGE**

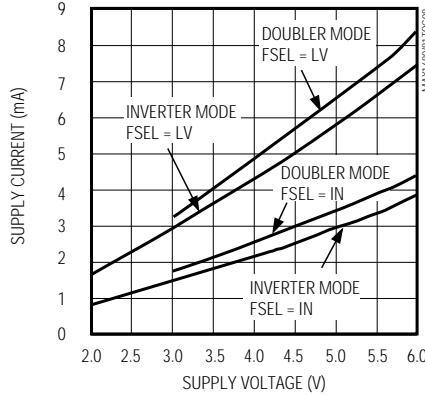

**MAX1681 SUPPLY CURRENT vs. SUPPLY VOLTAGE**

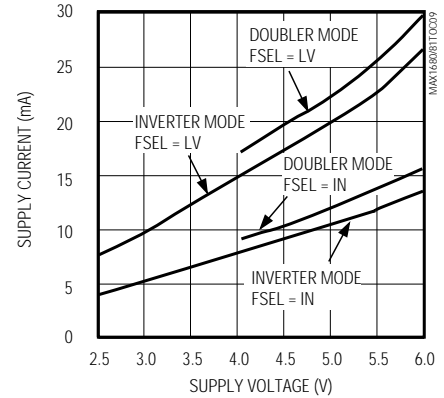

**MAX1680 OUTPUT SOURCE RESISTANCE vs. CAPACITANCE (INVERTER CONFIGURATION)**

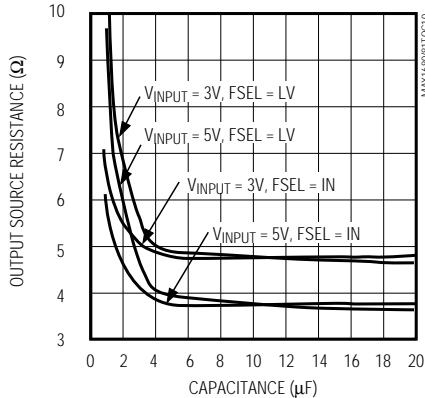

**MAX1680 OUTPUT SOURCE RESISTANCE vs. CAPACITANCE (DOUBLER CONFIGURATION)**

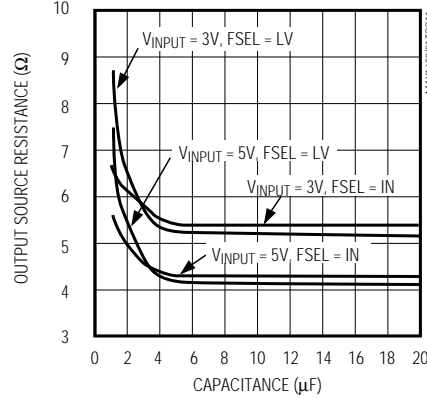

**MAX1681 OUTPUT SOURCE RESISTANCE vs. CAPACITANCE (INVERTER CONFIGURATION)**

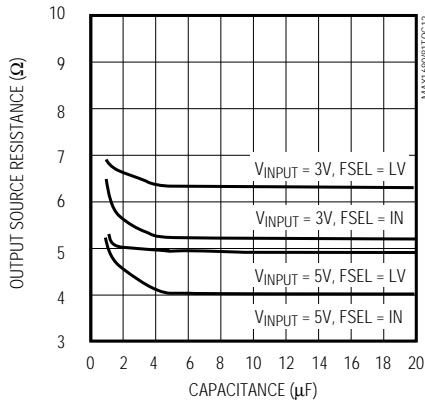

**MAX1681 OUTPUT SOURCE RESISTANCE vs. CAPACITANCE (DOUBLER CONFIGURATION)**

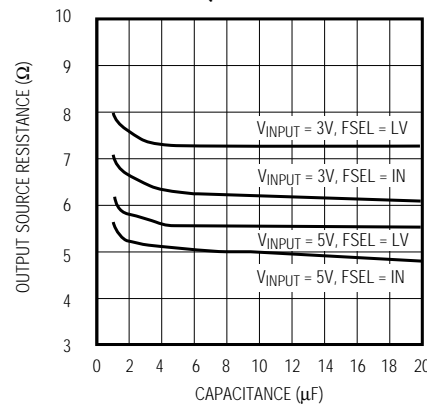

# 125mA, Frequency-Selectable, Switched-Capacitor Voltage Converters

## Pin Description

PIN	NAME	FUNCTION	
		INVERTER	DOUBLER
1	FSEL	Selects operating frequency. MAX1680: 250kHz when FSEL is low, 125kHz when FSEL is high. MAX1681: 1MHz when FSEL is low, 500kHz when FSEL is high.	
2	CAP+	Positive Charge-Pump Capacitor Connection	
3	GND	Power-Supply Ground Input	Power-Supply Positive Voltage Input
4	CAP-	Negative Charge-Pump Capacitor Connection	
5	OUT	Negative Voltage Output	Power-Supply Ground Connection
6	LV	Logic Voltage Input. Connect LV to GND.	Connect LV to OUT.
7	SHDN	Shutdown Input. Driving SHDN high disables the charge pump, and the output goes to 0V. SHDN is a CMOS input.	Not available; connect to OUT.
8	IN	Power-Supply Positive Voltage Input	Positive Voltage Output

### Detailed Description

The MAX1680/MAX1681 switched-capacitor voltage converters either invert or double the input voltage. They have low output resistance ( $3.5\Omega$ ) and can deliver up to 125mA output current. These devices operate at one of two selectable frequencies: 125kHz/250kHz (MAX1680) and 500kHz/1MHz (MAX1681). This provides the flexibility to optimize capacitor size, operating supply current, and overall circuit efficiency. Frequency selection also allows for minimizing coupling into other sensitive circuits. These devices contain no internal divider; the oscillator frequency equals the switching frequency. The devices can easily be cascaded to produce a higher output voltage, or paralleled to deliver more current.

The MAX1680/MAX1681 feature a shutdown mode that reduces supply current to  $<1\mu\text{A}$  (SHDN = high). OUT, in the inverter configuration, pulls to ground in shutdown mode. Shutdown is not available in the doubler configuration; connect SHDN to OUT.

### Applications Information

#### Voltage Inverter

A simple voltage inverter is the most common MAX1680/MAX1681 application. It requires three external capacitors (including the input bypass capacitor) as shown in the *Typical Operating Circuits* (inverter configuration). Although the output is not regulated, low

output resistance produces a typical drop of only 0.44V with a 125mA load. This low output resistance makes the devices fairly insensitive to changes in load (see the graphs for Output Source Resistance vs. Temperature and Supply Voltage in the *Typical Operating Characteristics* section).

#### Voltage Doubler

The MAX1680/MAX1681 can be configured as a voltage doubler with two external capacitors as shown in the *Typical Operating Circuits* (doubler configuration). When loaded, the output voltage drop is similar to that of the voltage inverter. The minimum input supply range is slightly higher than in the inverter configuration. Calculate ripple voltage using the equation in the *Capacitor Selection* section.

#### Frequency Control

A frequency-control pin, FSEL, provides design flexibility. Each device has two selectable frequencies: 125kHz/250kHz (MAX1680) and 500kHz/1MHz (MAX1681). This allows optimization of capacitor size and supply current for a given output load. Table 1 summarizes the frequency options.

**Table 1. Nominal Switching Frequencies**

FSEL CONNECTION	FREQUENCY (kHz)	
	MAX1680	MAX1681
FSEL = LV	250	1000
FSEL = IN	125	500

# 125mA, Frequency-Selectable, Switched-Capacitor Voltage Converters

MAX1680/MAX1681

## Operating Frequency Trade-Offs

It is important to recognize the trade-offs between switching frequency, power consumption, noise, cost, and performance. Higher frequency switching reduces capacitor size while maintaining the same output impedance, thus saving capacitor cost and board space. Lower frequency designs use less supply current. Table 2 summarizes the relative trade-offs.

**Table 2. Switching-Frequency Trade-Offs**

ATTRIBUTE	LOWER FREQUENCY	HIGHER FREQUENCY
Output Ripple	Larger	Smaller
C1, C2 Values	Larger	Smaller
Supply Current	Smaller	Larger

## Capacitor Selection

The MAX1680/MAX1681 are tested with capacitor values of 10 $\mu$ F and 2.2 $\mu$ F, respectively. Capacitor size and switching speed determine output resistance. Larger C1 values decrease the output resistance until the internal switch resistance (3.5 $\Omega$  typ) becomes the dominant term. Low-ESR capacitors minimize output resistance and ripple voltage. The entire circuit's output resistance can be approximated by the following equation:

$$R_{OUT} \approx R_0 + 4 \times ESR_{C1} + ESR_{C2} + [1 / (f_{OSC} \times C1)] + [1 / (f_{OSC} \times C2)]$$

where  $R_0$  is the device's internal effective switch resistance and  $f_{OSC}$  is the switching frequency. Output

resistance is a critical circuit component, as it determines the voltage drop that will occur at the output from the ideal value of  $-V_{INPUT}$  (or  $2V_{INPUT}$  when doubling).

To optimize performance, minimize overall resistance in the system. In particular, equivalent series resistance (ESR) in the capacitors produces significant losses as large currents flow through them. Therefore, choose a low-ESR capacitor for highest efficiency. Table 3 lists recommended capacitors and their suppliers.

Calculate the output ripple voltage as follows:

$$V_{RIPPLE} = [(I_{OUT}) / (2 \times f_{OSC} \times C2)] + 2 \times (I_{OUT} \times ESR_{C2})$$

where  $I_{OUT}$  is the load current,  $f_s$  is the charge pump's operating frequency,  $C2$  is the output capacitor, and  $ESR_{C2}$  is the output capacitor's ESR.

Table 4 lists the minimum recommended capacitances that allow for the maximum output current. The output capacitor,  $C2$ , is normally equal to or greater than the charge-pump capacitor,  $C1$ . Capacitor values can be scaled directly proportional to the input voltage, frequency, and load current. For example, for  $V_{INPUT} = 5V$ ,  $I_{LOAD} = 125mA$  at  $f_{OSC} = 125kHz$ , a 6.4 $\mu$ F minimum capacitor is recommended. For an output of only 62.5mA, a 3.2 $\mu$ F capacitor is recommended.  $C1$ 's value can be estimated as follows:

$$C1 = 6.4\mu F \times (V_{INPUT} / 5.0V) \times (125kHz / f_{OSC}) \times (I_{LOAD} / 125mA)$$

where  $f_{OSC}$  is the switching frequency (kHz) and  $I_{LOAD}$  is the output current (mA) required.

**Table 3. Low-ESR Capacitor Suppliers**

SUPPLIER	PHONE	FAX	DEVICE TYPE
AVX	(803) 946-0690 (800) 282-4975	(803) 626-3123	Surface mount, TPS series
Marcon/United Chemi-Con	(847) 696-2000	(847) 696-9278	Ceramic capacitors
Matsuo	(714) 969-2491	(714) 960-6492	Surface mount, 267 series
Nichicon	USA: (847) 843-7500 Japan: 81-7-5231-8461	USA: (847) 843-2798 Japan: 81-7-5256-4158	Through-hole, PL series
Sanyo	USA: (619) 661-6835 Japan: 81-7-2070-6306	USA: (619) 661-1055 Japan: 81-7-2070-1174	Through-hole, OS-CON series
Sprague	(603) 224-1961	(603) 224-1430	Surface mount, 595D series
TDK	(847) 390-4373	(847) 390-4428	Ceramic capacitors
United Chemi-Con	(714) 255-9500	(714) 255-9400	Through-hole, LXF series
Vishay/Vitramon	(203) 268-6261	(203) 452-5670	SMT ceramic chip capacitors

# 125mA, Frequency-Selectable, Switched-Capacitor Voltage Converters

**Table 4. Minimum Recommended Capacitances for Maximum Output Current**

fosc (kHz)	CAPACITANCE (μF) (C1 = C2)			
	V <sub>IN</sub> = 2V	V <sub>IN</sub> = 3V	V <sub>IN</sub> = 4V	V <sub>IN</sub> = 5V
125	2.5	3.8	5.1	6.4
250	1.2	1.9	2.5	3.2
500	0.6	0.9	1.2	1.6
1000	0.3	0.4	0.6	0.8

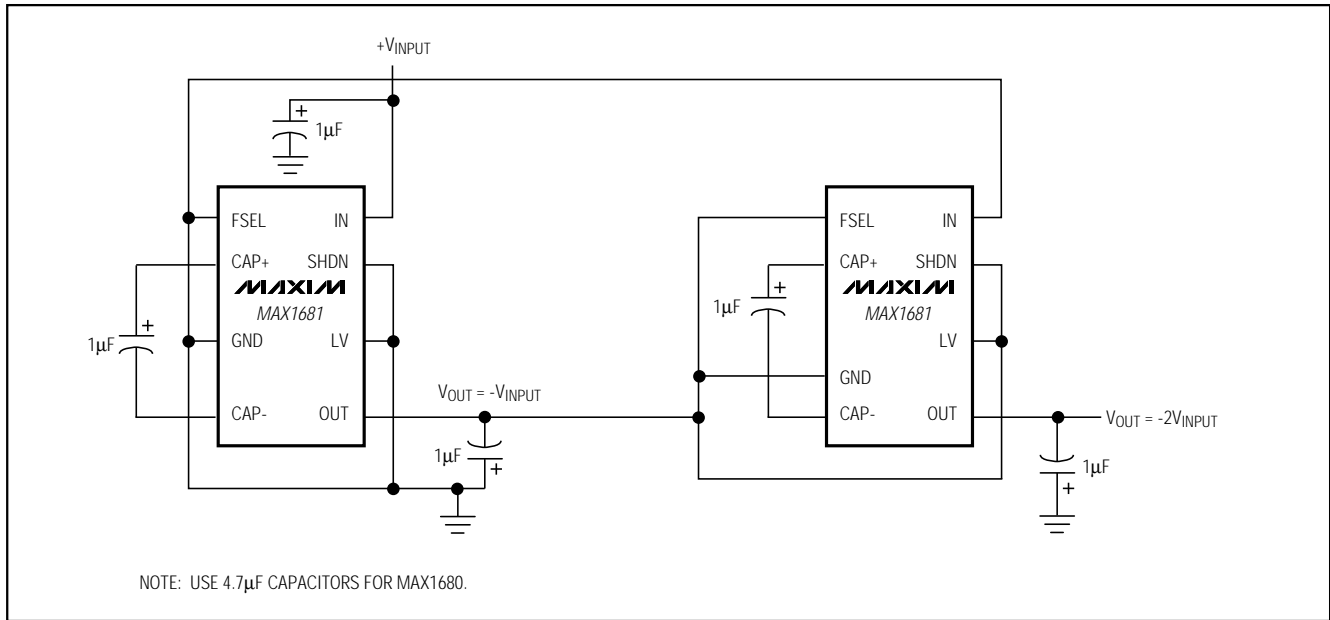

Figure 1. Cascading MAX1680/MAX1681s to Increase Output Voltage

### Bypass Capacitor

Bypass the input voltage to reduce AC impedance and to prevent internal switching noise. Bypassing depends on the source impedance location. The AC ripple current is  $2 \times I_{OUT}$  for the doubler and the inverter. Use a large bypass capacitor (equal to C1) if the supply has high AC impedance.

### Cascading Devices

To produce larger negative voltages, cascade two devices (Figure 1). For two devices, the unloaded output voltage is approximately  $-2 \times V_{INPUT}$ , but this value is reduced slightly by the first device's output resistance multiplied by the second device's quiescent current. The effective output resistance for a cascaded

device is larger than that for an individual device ( $20\Omega$  for two devices). Cascading several devices increases output resistance and reduces efficiency. If a large negative voltage is required for several stages, an inductive inverting switching regulator such as the MAX629 or MAX774 may offer more advantages.

### Paralleling Devices

Parallel two or more MAX1680/MAX1681s to reduce output resistance voltage drop under a given load. With reduced output resistance, paralleled devices deliver higher load currents. Figure 2 shows two MAX1680/MAX1681s connected in parallel. Output resistance is inversely proportional to the number of devices.



# 125mA, Frequency-Selectable, Switched-Capacitor Voltage Converters

MAX1680/MAX1681

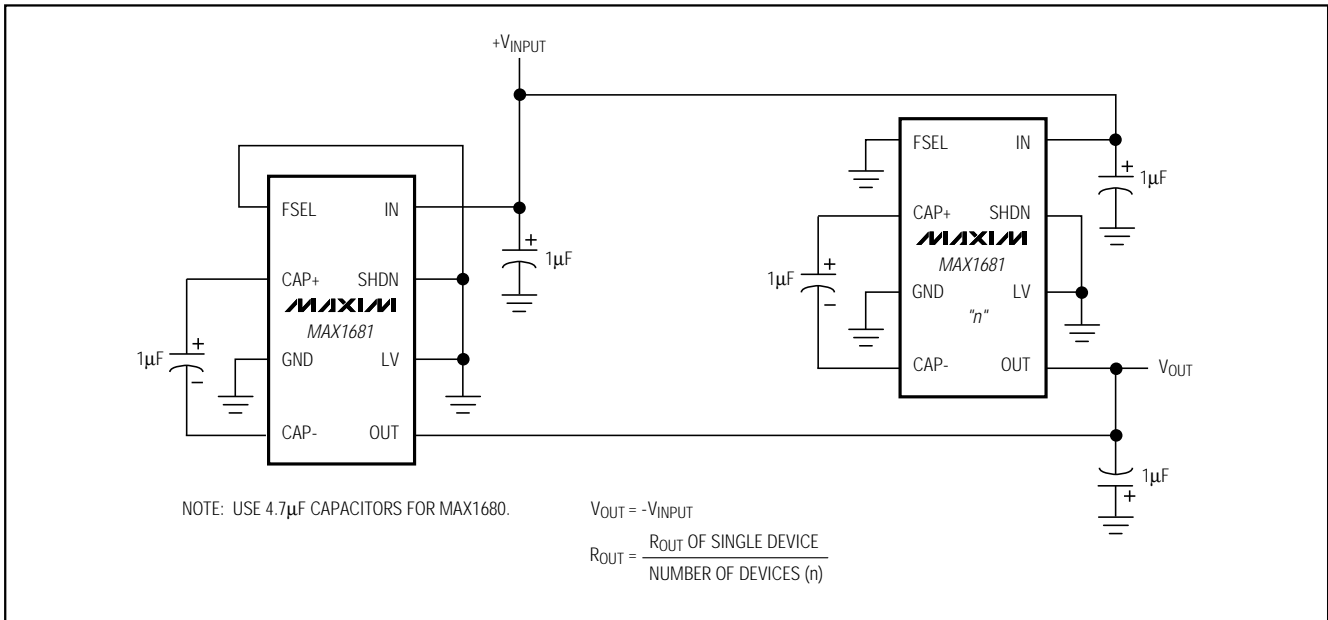

Figure 2. Paralleling MAX1680/MAX1681s to Increase Output Current

## Combined Doubler and Inverter

Figure 3 shows a single MAX1680/MAX1681 as an inverter and a doubler. The maximum output current is the sum of the loads on the two outputs and is still limited to 125mA. As the device is loaded, the output voltages move toward ground. In this particular configuration, connect LV to GND (inverter). The diodes used in the circuit cause a drop of approximately 0.7V in the doubler's output voltage, impacting efficiency.

## Compatibility with the MAX660 and MAX860/MAX861

The MAX1680/MAX1681 can be used in place of the MAX860/MAX861, except for the SHDN and FSEL pins. The MAX1680/MAX1681 shut down with a high input voltage, compared with the MAX860/MAX861. The MAX1680/MAX1681 have only two frequency choices.

Replacing the MAX660 with the MAX1680/MAX1681 involves a wiring change, as the external oscillator pin is replaced by the shutdown feature. Table 5 compares the devices.

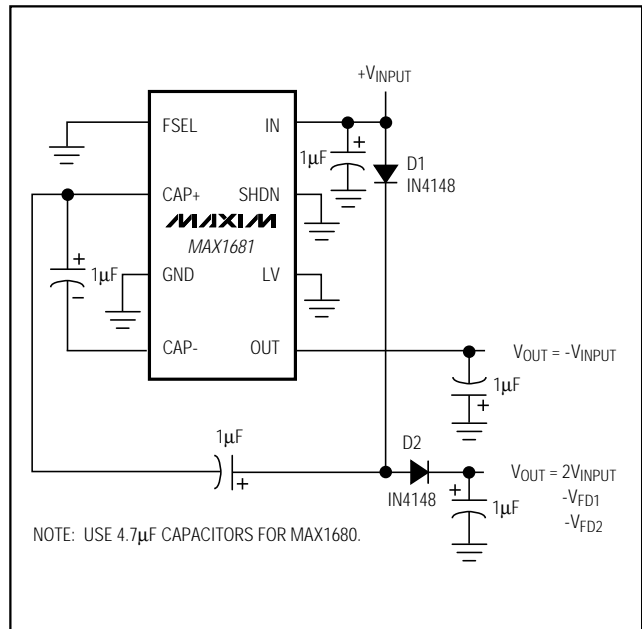

Figure 3. Combined Doubler and Inverter

# 125mA, Frequency-Selectable, Switched-Capacitor Voltage Converters

**Table 5. Device Comparison**

PART NUMBER	TYPICAL QUIESCENT CURRENT (mA)	OUTPUT CURRENT (mA)	OUTPUT RESISTANCE ( $\Omega$ )	SWITCHING FREQUENCY (kHz)
MAX660	0.12/1.0	100	6.5	5/40
MAX665	0.20/1.0	100	6.5	5/40
MAX860	0.20/0.60/1.40	50	12	6/50/130
MAX861	0.30/1.10/2.50	50	12	13/100/250
MAX1680	2.5/5.0	125	3.5	125/250
MAX1681	10/20	125	3.5	500/1000
ICL7660	0.080	10	55	5

Pin Configuration

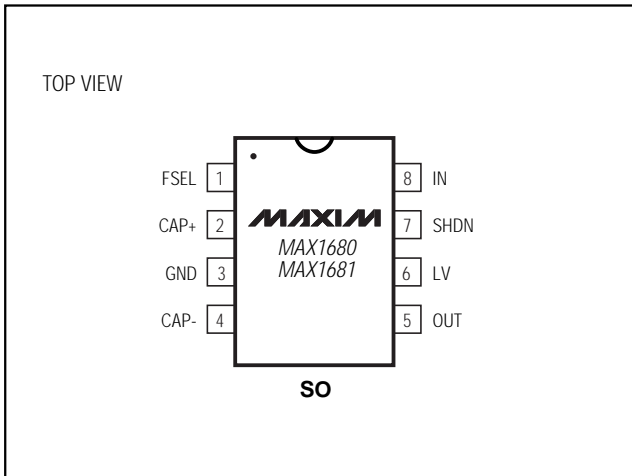

Chip Information

TRANSISTOR COUNT: 171  
SUBSTRATE CONNECTED TO IN

# 125mA, Frequency-Selectable, Switched-Capacitor Voltage Converters

## Package Information

MAX1680/MAX1681

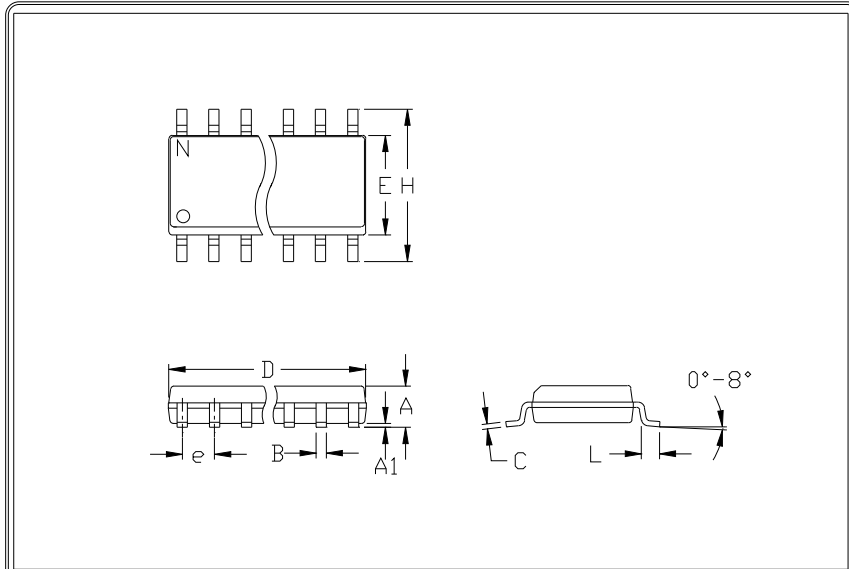

	INCHES		MILLIMETERS	
	MIN	MAX	MIN	MAX
A	0.053	0.069	1.35	1.75
A1	0.004	0.010	0.10	0.25
B	0.014	0.019	0.35	0.49
C	0.007	0.010	0.19	0.25
e	0.050		1.27	
E	0.150	0.157	3.80	4.00
H	0.228	0.244	5.80	6.20
h	0.010	0.020	0.25	0.50
L	0.016	0.050	0.40	1.27

	INCHES		MILLIMETERS		N	MS012
	MIN	MAX	MIN	MAX		
D	0.189	0.197	4.80	5.00	8	A
D	0.337	0.344	8.55	8.75	14	B
D	0.386	0.394	9.80	10.00	16	C

NOTES:

1. D&E DO NOT INCLUDE MOLD FLASH
2. MOLD FLASH OR PROTRUSIONS NOT TO EXCEED .15mm (.006")
3. LEADS TO BE COPLANAR WITHIN .102mm (.004")
4. CONTROLLING DIMENSION: MILLIMETER
5. MEETS JEDEC MS012-XX AS SHOWN IN ABOVE TABLE
6. N = NUMBER OF PINS



PACKAGE FAMILY OUTLINE: SOIC .150"

1/1

21-0041 A  
DOCUMENT CONTROL NUMBER REV

# 125mA, Frequency-Selectable, Switched-Capacitor Voltage Converters

## NOTES

MAX1680/MAX1681

*Maxim cannot assume responsibility for use of any circuitry other than circuitry entirely embodied in a Maxim product. No circuit patent licenses are implied. Maxim reserves the right to change the circuitry and specifications without notice at any time.*

**12** \_\_\_\_\_ Maxim Integrated Products, 120 San Gabriel Drive, Sunnyvale, CA 94086 408-737-7600

© 1997 Maxim Integrated Products

Printed USA

**MAXIM** is a registered trademark of Maxim Integrated Products.