

Reference Design Note

MagI³C Power Modules DNS002 MagI³C Power Supply



1. Introduction

The MagI³C Power Supply demonstrates how a MagI³C Power Module can be used for applications that require additional power supply functionalities.

An adjustable output current limit can be set from 0mA to the maximum continuous output current of the module, turning the module into a constant current source or still acting as a voltage source but with a user defined current limit.

An electronic fuse can be implemented by triggering on the “current limit” LED and pulling the enable pin low to shut down the MagI³C Power Module immediately after a current limit event.

Output voltage and current can have arbitrary waveforms. An example is imitating the behavior of a car battery voltage during engine start up to test if the radio is malfunctioning.

Batteries can be charged with a DC current or with a defined charging current waveform, if a digital to analog converter or a PWM output of a microcontroller is used instead of the potentiometer for current adjustment. Other possibilities include end of charge voltage as well as super capacitor charging.

High power LEDs can be supplied up to 2.5A.

The point of regulation can be moved away from the MagI³C Power Module towards the load. This allows regulation of the voltage at a distant point while the output voltage of the module adapts to the voltage drops on the supply lines.

During the development of a customer’s prototype, the MagI³C Power Supply can be implemented into the prototypes housing until the power supply is defined for the final product.

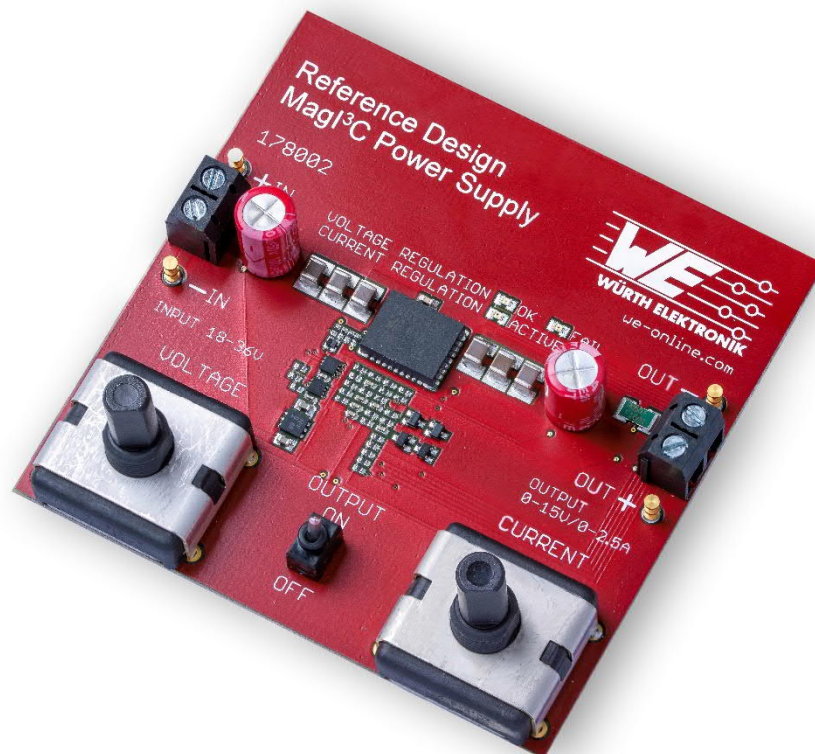

Figure 1. MagI³C Power Supply – Order Code 178002

Reference Design Note

MagI³C Power Modules DNS002 MagI³C Power Supply



2. Specifications

Electrical Specifications

- Input Voltage Range 7V – 36V
- Input Voltage Transients Max. 45V
- Output Voltage Range 0V – 15V
- Output Current Limit 0A – 2.5A
- Maximum Output Power 37.5W
- Switching Frequency 1MHz

Features

- Output On/Off Mechanical Switch
- Constant Voltage Indicator LED green
- Constant Current Indicator LED red
- Output Fail Indicator LED red

3. Functional Diagram

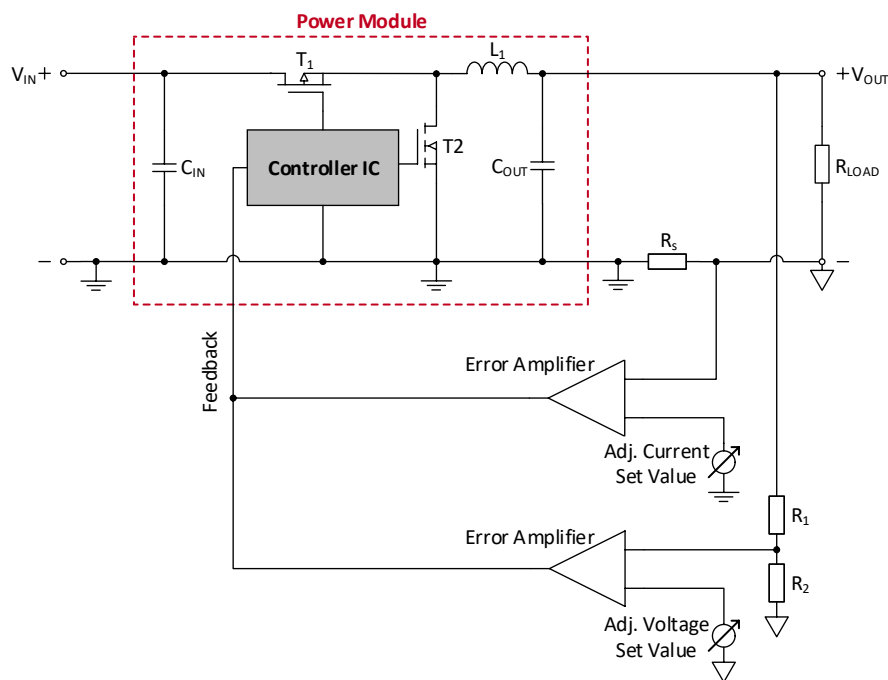

Figure 2. Functional Diagram

The output voltage of the MagI³C Power Module, normally fixed by the feedback resistor divider R₁ and R₂, is now adjustable during operation by one of the error amplifiers. It can even be regulated below the internal reference of the MagI³C Power Module down to 0V while continuing to be actively regulated.

The output current is measured by R_s and compared with an internal reference by the second error amplifier.

Either the error amplifier for voltage regulation is active and maintains the output voltage according to the user set value or the error amplifier for current regulation is active and maintains the output current according to the user set value.

Reference Design Note

MagI³C Power Modules DNS002 MagI³C Power Supply



4. Circuit Description

In figure 3, C1 is the bulk capacitor of the input of the reference design. This capacitor decreases possible oscillations, which may occur due to the mismatch between the line impedance and the “negative input resistance” of the power module. C2, C3, C4 and C5 are the low impedance input capacitors for the power module. The switching current flows through these capacitors when the power module’s high side FET conducts. It is recommended to choose all input capacitors of the same type (order code) to prevent resonance between the capacitors with different impedances. The capacitor C5 is placed in a way that minimizes the copper track length between the VIN pin of the power module and the capacitor and still maintaining a short path to PGN. C6, C7 and C8 are the output capacitors of the power module. These are MLCC types with very low ESR and assure a low output voltage ripple. It is recommended to choose all output capacitors to be the same type. The capacitor C9 is used to decrease the transient response deviation of the output voltage and is an aluminum electrolytic capacitor which offers a very high capacitance value. The resistor R26 sets the internal switching frequency to 1MHz. The output resistor divider R4 and R11 sets the output voltage to 15.8V, slightly above the maximum Vout of 15V, controlled by the external loop. Any current through R2 which passes also R11 will be subtracted from the current in R4 because the regulation of the power module maintains the feedback node at 0.8V. This basic principle shows that the output voltage as well as the output current can be set to any value between 0V and 15V and 0A to 2.5A respectively, by adjusting the current through R2.

4.1 Output Voltage Regulation

The current measurement shunt resistor R3 is located between the ground of the regulation circuit and the output ground (CON 22). Therefore there will be a decrease in output voltage by $V_{RSHUNT} (50m\Omega \cdot I_{OUT})$. To eliminate this undesired voltage drop of the current sense resistor R3, the output voltage is measured in addition at the capacitor C9 with the resistor divider R1 and R32. The voltage across the resistor R3 is subtracted from the output voltage by the error amplifiers IC5-2 and IC5-3. The result is the actual output voltage value referenced to analog ground which is passed to the error amplifier IC3-2, for voltage regulation. The set value of the output voltage is adjusted by the potentiometer R29 and passed to the error amplifier IC3-2, which regulates the output voltage by maintaining the non inverting input to the same voltage level as the inverting input.

4.2 Output Current Regulation

The voltage across the current sense resistor R3 is proportional to the output current and referenced to the analog ground via the layout. This actual value of the output current is passed to the error amplifier IC3-3 which maintains it to the set value of the output current given by the potentiometer R30.

4.3 Interaction of Voltage and Current Regulation

When D1 conducts, indicating that the current regulation is active by IC3-3, the output voltage is always lower compared to the value set by the potentiometer R29. This results in a lower voltage at the non inverting input of the error amplifier IC3-2 compared to its inverting input. As a result the output voltage value of IC3-2 is decreased and blocked by the diode D3 and will not affect the active current regulation.

When D3 conducts, indicating that the voltage regulation is active by IC3-2, the output current is always lower compared to the value set by the potentiometer R30. This results in a lower voltage at the non inverting input of the error amplifier IC3-3 compared to its inverting input. As a result the output voltage value of IC3-3 is decreased and blocked by the diode D1 and will not affect the active voltage regulation.

4.4 Functions of the LEDs

If the current regulation is active, the red LED, D4, will glow. It is marked on the reference design board with “current regulation”. The green LED D2 and the red LED D5, are based on the power good signal of the Power Module. If the feedback voltage of the Power Module is within a small window around the internal reference voltage, the green LED, D2, will glow. It is marked on the reference design board with “voltage regulation”. If the power good signal indicates a failure the red LED, D4, will glow. It is marked on the reference design board with “fail”.

Reference Design Note

MagI³C Power Modules DNS002 MagI³C Power Supply



4.5 Auxiliary Power

The linear regulator IC2 is used to supply the error amplifiers and the LEDs with 5V. In addition the potentiometers R29 and R30 adjust their set values from the 5V supply. The level shifters of the external error amplifiers which compensate the input offset voltage are supplied as well from the 5V.

4.6 Optional Setting of Voltage and Current Using a Microcontroller

The output voltage and the output current limit can be dynamically set by PWM signals from a microcontroller. The potentiometers must be disconnected and the PWM signals from the microcontroller must be connected to the appropriate net where the wiper of the potentiometer was connected. The resistors R25 and R24 and the resistors R20 and R22 respectively scale down the PWM high state voltage to fit the end scale voltages of the actual values of the maximum output voltage (1.37V) and the maximum output current (125mA).

4.7 Design Limitations

The maximum operating input voltage of 36V has been chosen to allow the use of 50V ceramic input capacitors and a linear regulator in a very small package.

Reference Design Note

MagI³C Power Modules DNS002 MagI³C Power Supply



5. Schematic

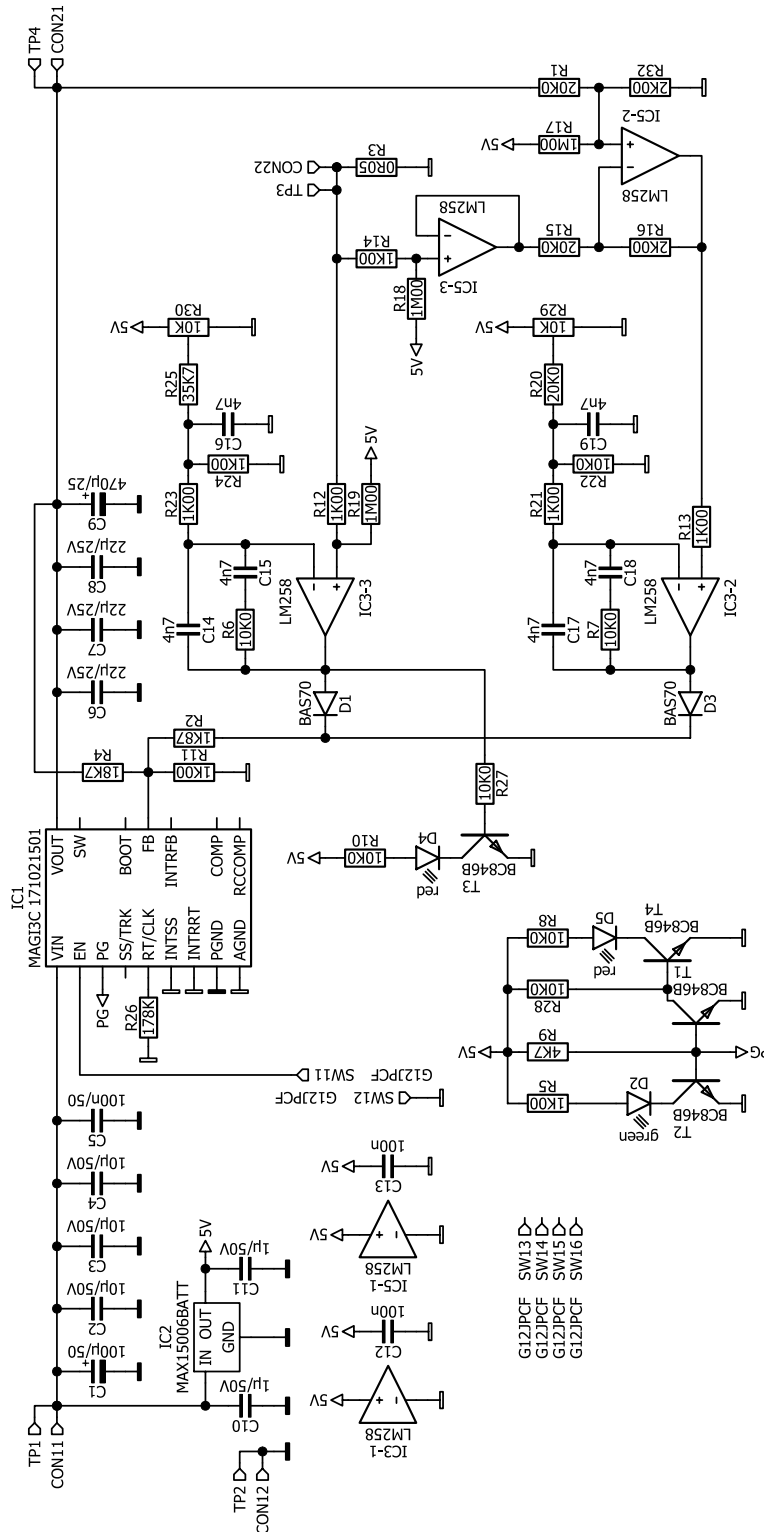

Figure 3. MagI³C Power Supply Schematic

Reference Design Note

MagI³C Power Modules
DNS002 MagI³C Power Supply



6. Assembly Drawing

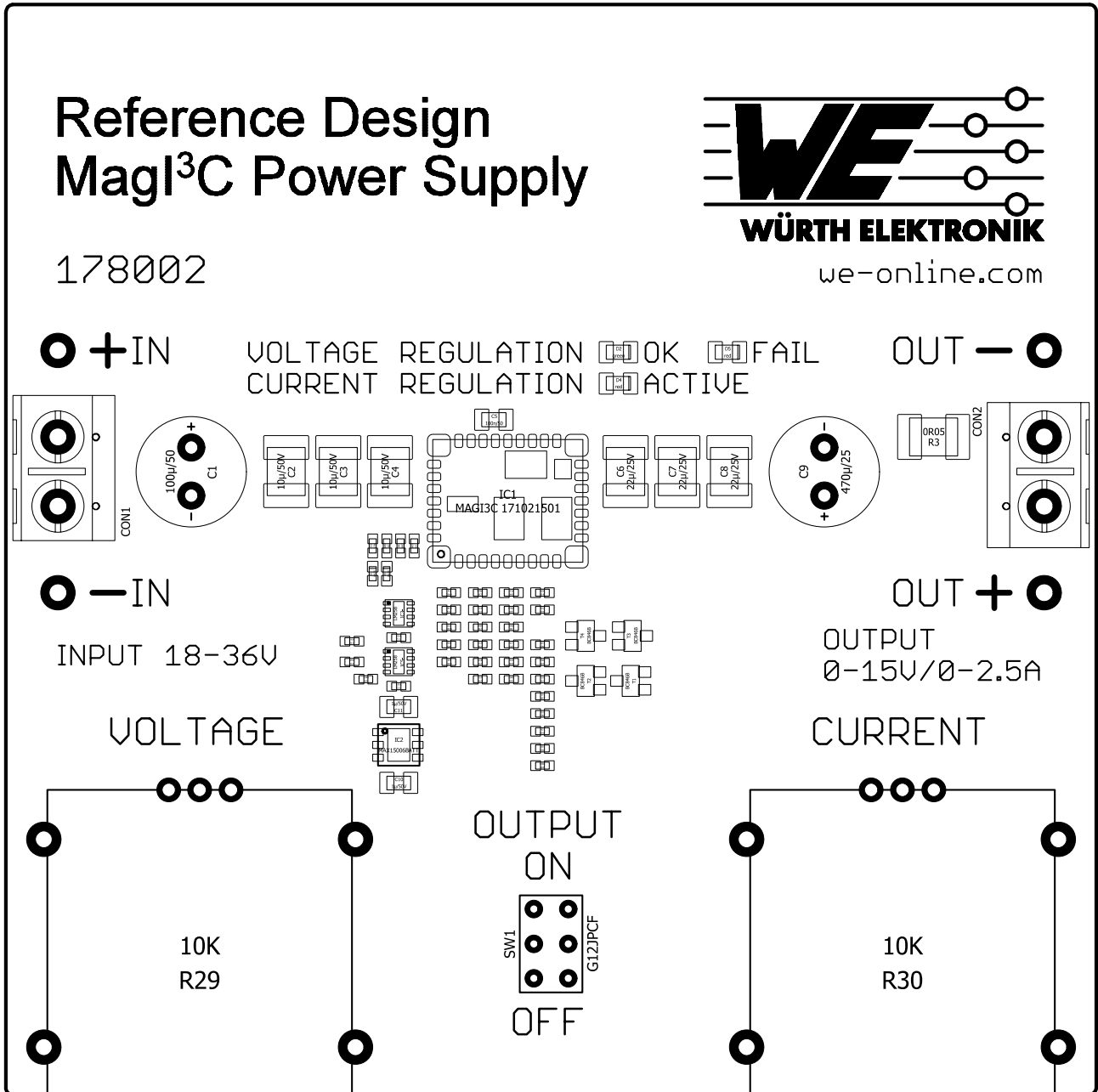

Figure 4. Assembly Drawing (Zoomable Vector Graphic)

Reference Design Note

Magl³C Power Modules DNS002 Magl³C Power Supply



7. Bill of Material

Designator	Value	Description	Quantity	Package	Manufacturer	Order Code
C1	100μ/50V	Electrolytic Capacitor	1		Würth Elektronik	860010674014
C2,C3,C4	10μ/50V/X5R	Ceramic Capacitor	3	1210		
C5	100n/50V/X7R	Ceramic Capacitor	1	0603	Würth Elektronik	885012206095
C6,C7,C8	22μ/25V/X5R	Ceramic Capacitor	3	1210	Würth Elektronik	885012109014
C9	470μ/25V	Electrolytic Capacitor	1		Würth Elektronik	860020474014
C10,C11	1μ/50V/X5R	Ceramic Capacitor	2	0603		
C12,C13	100n/16V/X5R	Ceramic Capacitor	2	0402	Würth Elektronik	885012105016
C14-C19	4n7/16V/X7R	Ceramic Capacitor	6	402	Würth Elektronik	885012205029
CON1,CON2		Terminal Block	2		Würth Elektronik	608000502000
D1,D3	BAS70LP-7B	Diode	2	0402	Diodes Incorporated	BAS70LP-7B
D2	LED green	LED green	1	0603	Würth Elektronik	150060VS75000
D4,D5	LED red	LED red	2	0603	Würth Elektronik	150060RS75000
IC1	171021501	Magl ³ C Power Module	1	QFN41	Würth Elektronik	171021501
IC2	MAX15006	Linear Regulator	1	6TDFN	Maxim	MAX15006BATT
IC3,IC5	LM258QT	Operational Amplifier	2	DFN8	STMicroelectronics	LM258QT
R1,R15,R20	20.0kΩ 1%/100ppm	Resistor	3	0402		
R2	1.87kΩ 1%/100ppm	Resistor	1	0402		
R3	50mΩ	Shunt Resistor	1	1210	Isabellenhütte	VMP-R050-1.0
R4	18.7kΩ 1%/100ppm	Resistor	1	0402		
R5,R11-R14, R21,R23,R24	1.00kΩ 1%/100ppm	Resistor	8	0402		
R6- R8,R10,R22, R27,R28	10.0kΩ 1%/100ppm	Resistor	7	0402		
R9	4.75kΩ 1%/100ppm	Resistor	1	0402		
R16,R32	2.00kΩ 1%/100ppm	Resistor	2	0402		
R17-R19	1.00MΩ 1%/100ppm	Resistor	3	0402		
R29,R30	20KΩ	Potentiometer	2		Bourns	PCW1JC24BAB103L
SW1		Switch	1		NKK	G12JPCF
T1-T4	BC846B	NPN Transistor	4	SOT323/ SC70	OnSemiconductor	BC846B
TP1-TP4	Testpoint	Pin Fork Terminal	4		WE/Stelvio Kontek	3110325000500

Figure 5. Bill of Material

Reference Design Note

MagI³C Power Modules DNS002 MagI³C Power Supply



8. Important Notes

This Reference Design Note / Application Note is based on our knowledge and experience of typical requirements concerning these areas. It serves as general guidance and should not be construed as a commitment for the suitability for customer applications by Würth Elektronik eiSos GmbH & Co. KG. The information in the Application Note is subject to change without notice. This document and parts thereof must not be reproduced or copied without written permission, and contents thereof must not be imparted to a third party nor be used for any unauthorized purpose.

Würth Elektronik eiSos GmbH & Co. KG and its subsidiaries and affiliates (WE) are not liable for application assistance of any kind. Customers may use WE's assistance and product recommendations for their applications and design. The responsibility for the applicability and use of WE Products in a particular customer design is always solely within the authority of the customer. Due to this fact it is up to the customer to evaluate and investigate, where appropriate, and decide whether the device with the specific product characteristics described in the product specification is valid and suitable for the respective customer application or not.

The technical specifications are stated in the current data sheet of the products. Therefore the customers shall use the data sheets and are cautioned to verify that data sheets are current. The current data sheets can be downloaded at www.we-online.com. Customers shall strictly observe any product-specific notes, cautions and warnings. WE reserves the right to make corrections, modifications, enhancements, improvements, and other changes to its products and services.

WE DOES NOT WARRANT OR REPRESENT THAT ANY LICENSE, EITHER EXPRESS OR IMPLIED, IS GRANTED UNDER ANY PATENT RIGHT, COPYRIGHT, MASK WORK RIGHT, OR OTHER INTELLECTUAL PROPERTY RIGHT RELATING TO ANY COMBINATION, MACHINE, OR PROCESS IN WHICH WE PRODUCTS OR SERVICES ARE USED. INFORMATION PUBLISHED BY WE REGARDING THIRD-PARTY PRODUCTS OR SERVICES DOES NOT CONSTITUTE A LICENSE FROM WE TO USE SUCH PRODUCTS OR SERVICES OR A WARRANTY OR ENDORSEMENT THEREOF.

WE products are not authorized for use in safety-critical applications, or where a failure of the product is reasonably expected to cause severe personal injury or death. Moreover, WE products are neither designed nor intended for use in areas such as military, aerospace, aviation, nuclear control, submarine, transportation (automotive control, train control, ship control), transportation signal, disaster prevention, medical, public information network etc. Customers shall inform WE about the intent of such usage before design-in stage. In certain customer applications requiring a very high level of safety and in which the malfunction or failure of an electronic component could endanger human life or health, customers must ensure that they have all necessary expertise in the safety and regulatory ramifications of their applications. Customers acknowledge and agree that they are solely responsible for all legal, regulatory and safety-related requirements concerning their products and any use of WE products in such safety-critical applications, notwithstanding any applications-related information or support that may be provided by WE. CUSTOMERS SHALL INDEMNIFY WE AGAINST ANY DAMAGES ARISING OUT OF THE USE OF WE PRODUCTS IN SUCH SAFETY-CRITICAL APPLICATIONS.

USEFUL LINKS

Application Notes / Reference Design Notes
<https://www.we-online.com/app-notes>

REDEXPERT Design Tool
<https://www.we-online.com/redexpert>

Toolbox
<https://www.we-online.com/toolbox>

MagI³C Product Catalog
<https://katalog.we-online.com/en/pm>

CONTACT INFORMATION

Technical Support
powermodules@we-online.com

Würth Elektronik eiSos GmbH & CO. KG
Max-Eyth-Str. 1, 74638 Waldenburg
Germany

Tel.: +49 7942 945 0
we-online.com