

MAX14914 Evaluation Kit

Evaluates: MAX14914/
MAX14914A/MAX14914B

General Description

The MAX14914 evaluation kit (EV kit) provides a proven design to evaluate the MAX14914/MAX14914A/MAX14914B, configurable industrial digital output drivers/digital inputs. The EV kit allows controlling of the MAX14914 as either a digital output (in either High-Side or Push-Pull mode) or digital input with simple jumper settings.

The EV kit must be powered from an external +24V power supply and can consume up to 1.3A (minimum) when fully loaded.

The MAX14914EVKIT comes with a MAX14914ATE+ installed in a 16-pin, 4x4mm TQFN-EP package.

MAX14914B overcurrent interrupt output is not directly supported. For the MAX14914B application refer to the [MAX14914 IC data sheet](#).

Features

- Robust Operation with Wide Range of Input Voltages and Load Conditions
- -40°C to +125°C Temperature Range
- On-Board LED Indication of Status and Fault Conditions
- Reverse Supply Voltage Protection
- Proven PCB Layout
- Fully Assembled and Tested

[Ordering Information](#) appears at end of data sheet.

MAX14914 EV Kit Board Photo

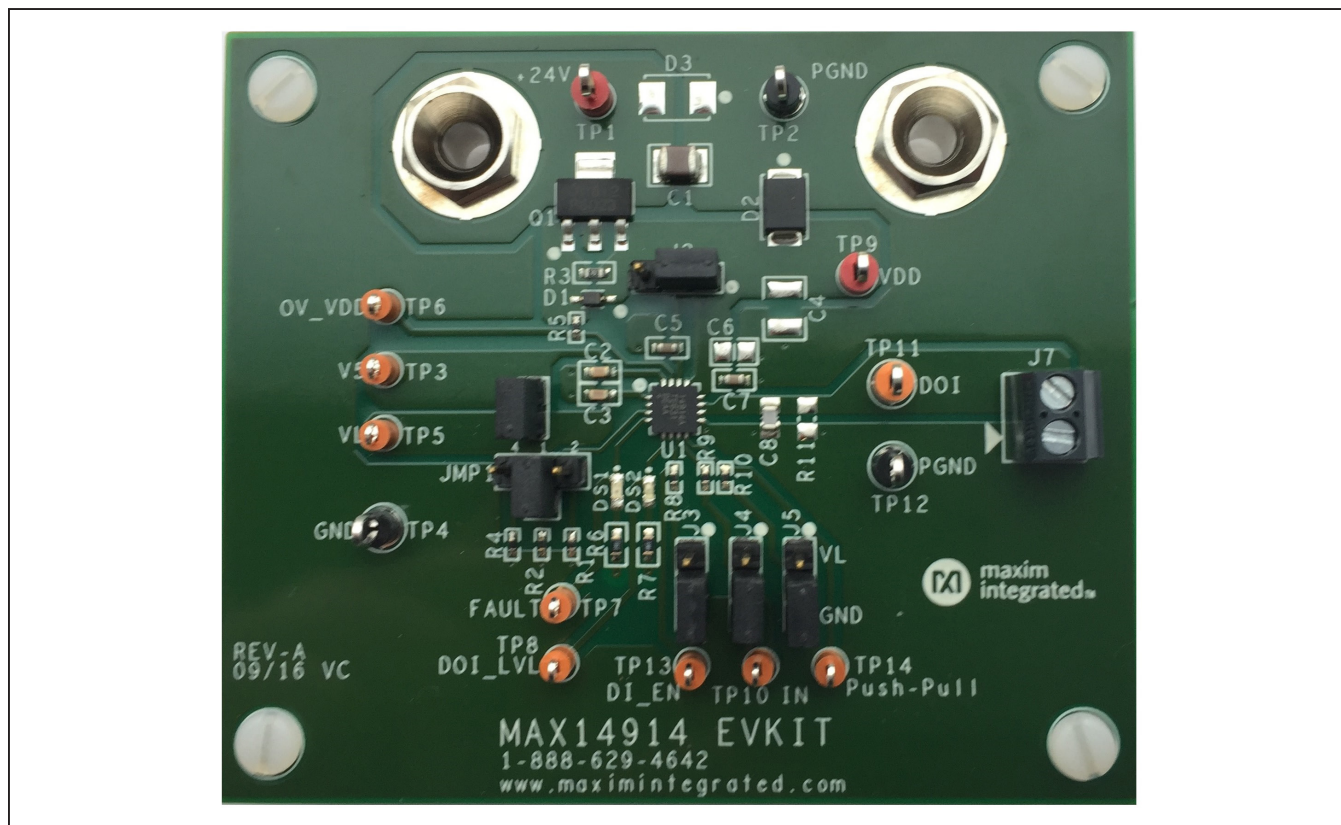

Table 1. MAX14914 Board Shunt Positions and Settings

HEADER	SHUNT POSITION	DESCRIPTION
J1	1-2*	Connected V_L to V_5 and set input logic level to 5V
	Open	Connect an external supply between TP5 (V_L) and TP4 (GND) to provide the user-defined input logic level from 2.5V to 5.5V
J2	1-2*	Input to the internal 5V regulator (REGIN) is from V_{DD} source
	2-3	Bypass the external voltage regulator and apply an external 5V supply to TP3 to power up the device.
	Open	Provide an external 6~40V supply to J2.2
J3	2-3*	Set DI_EN low to enable digital output (DO) operation
	1-2	Set DI_EN high to enable digital input (DI) operation
	Open	DO operation is enabled by internal weak pulldown resistor
J4	2-3*	Set IN low and DOI three-state/low
	1-2	Set IN high and DOI high
	Open	Provide square wave from function generator to TP10
J5	2-3*	Set PP low and DO High-Side mode or DI Type 1, 3 mode in conjunction with J3 setting
	1-2	Set PP high and DO Push-Pull mode or DI Type 2 mode in conjunction with J3 setting
	Open	Set PP low and DO High-Side mode or DI Type 1, 3 Mode by internal pulldown resistor in conjunction with J3 setting
JMP1	1-3*	Select $C_{LIM} = 51k$ and set current limit to ~900mA
	1-2	Select $C_{LIM} = 27k$ and set current limit to ~1.6A
	1-4	Select $C_{LIM} = 220k$ and set current limit to ~200mA
	Open	Current limit internally set to ~1.1A

*Default configuration

Detailed Description of Hardware

The MAX14914 EV kit allows the user to evaluate all the features and operational modes of the MAX14914 digital High-Side/Push-Pull driver. It also can be configured as a digital input level translator.

External Power Supply/Supplies

The EV kit is powered from a single power supply and accepts a wide range of input voltages, from 10V to 40V. The power is applied through two banana jacks, TP16 (+) and TP15 (-). The MAX14914 can drive up to 1.5A of current to the external load. The load is connected to the EV kit through the J7 terminal block.

The 24V field supply is reverse-voltage protected and tolerant up to 60V supply spikes. Reverse-voltage protection is achieved in the Q1 transistor. Refer to the MAX14914 EV kit schematic. The MAX14914 is immune to $\pm 2.0kV$ 1.2/50 μs surge pulses applied between the DOI and PGND load lines.

A power to the 5V internal regulator can be provided directly from either the V_{DD} pin or from an external supply; selectable at the J2 header. Refer to [Table 1](#) for details.

If a logic interface of less than 5V is used from a microcontroller (3.3V, for example), a secondary power supply is needed to power up the V_L pin through the TP5 test point with the correct voltage. In this case, the J1 header should be left open.

Digital Output Operation

The user can manually control the IN input either by shunt position on the J4 header (refer to [Table 1](#)) or by applying square wave to the TP10 from an external function generator or microcontroller. The J5 shunt sets either the High-Side or Push-Pull mode of operation. The High-Side mode is mostly used with the high current-resistive and inductive loads, while Push-Pull is often used for high-speed resistive and capacitive loads. The MAX14914 supports up to a 100kHz switching frequency. When using high-frequency push-pull mode switching, be aware that the 10nF (C8) capacitor charging/discharging current generates very high power dissipation in the MAX14914.

Digital Input Operation

When the DI_EN is high (J3 shunt in position 1-2) the MAX14914 works as digital input. In this mode, the input signal applied between the DOI pin (J7.2 or TP11) and PGND (J7.1 or TP12) is level-shifted and inverted to the output on TP8 (DOI_LVL). Note that the DOI_LVL is an open-drain output and needs a pullup to the V_L voltage level. DOI_LVL is logically inverted to the DOI input. So, the LED DS2 reflects the real logic state of the DOI input.

In digital input mode, the MAX14914 supports both IEC Type 1/3 as well as Type 3 inputs. Set J5/PP logic input high for Type 2 input characteristics.

Fault Indication

The fault LED (DS1) turns on when the driver exceeds 170°C or a loss of ground is detected. The DOI output is three-stated and the device will not operate until the fault condition disappears.

Ordering Information

PART	TYPE
MAX14914EVKIT#	EV Kit

#Denotes RoHS compliant.

MAX14914 Evaluation Kit

Evaluates: MAX14914
MAX14914A/MAX14914B

MAX14914 EV Kit Bill of Materials

ITEM	REF_DES	DN/DNP	QTY	MFG PART #	MANUFACTURER	VALUE	DESCRIPTION	COMMENTS
1	C1	-	1	GRM32ER71J106KA12	MURATA	10UF	CAPACITOR; SMT (1210); CERAMIC CHIP; 10UF; 63V; TOL = 10%; TG = -55°C TO +125°C; TC = X7R	
2	C2, C3	-	2	C0603C105K4RAC; GRM188R71C105KA12; C1608X7R1C105K; EMK107B7105KA	KEMET/MURATA/TDK/ TAIYO YUDEN	1UF	CAPACITOR; SMT (0603); CERAMIC CHIP; 1UF; 16V; TOL = 10%; MODEL = ; TG = -55°C TO +125°C; TC = X7R	
3	C5, C7	-	2	GCJ188R71H104KA12; GCM188R71H104K; CGA3E2X7R1H104K080AE	MURATA; TDK	0.1UF	CAPACITOR; SMT (0603); CERAMIC CHIP; 0.1UF; 50V; TOL = 10%; TG = -55°C TO +125°C; TC = X7R; AUTO	
4	C8	-	1	GRM2195C1H103JA01	MURATA	0.01UF	CAPACITOR; SMT; 0805; CERAMIC; 0.01uF; 50V; 5%; COG; -55°C to +125°C; 0730ppm/°C from -55°C to +125°C	
5	D1	-	1	MM3Z12VT1G	ON SEMICONDUCTOR	12V	DIODE; ZNR; SMT (SOD-323); PIV = 12V; IZ = 0.005A	
6	D2	-	1	SMBJ40A	BOURNS	40V	DIODE; TVS; SMB (DO-214AA); VRM = 40V; IPP = 9.3A	
7	DS1	-	1	LTST-C191KRKT	LITE-ON ELECTRONICS INC.	LTST-C191KRKT	DIODE; LED; SMD LED; RED; SMT (0603); VF = 2V; IF = 0.02A	
8	DS2	-	1	LGL29K-G2J1-24-Z	OSRAM	LGL29K-G2J1-24-Z	DIODE; LED; SMARTLED; GREEN; SMT; PIV=1.7V; IF=0.02A	
9	J1	-	1	PCC02SAAN	SULLINS	PCC02SAAN	CONNECTOR; MALE; THROUGH HOLE; BREAKAWAY; STRAIGHT THROUGH; 2PINS; -65°C TO +125°C	
10	J2-J5	-	4	PCC03SAAN	SULLINS	PCC03SAAN	CONNECTOR; MALE; THROUGH HOLE; BREAKAWAY; STRAIGHT THROUGH; 3PINS; -65°C TO +125°C	
11	J7	-	1	ED555/2DS	ON-SHORE TECHNOLOGY INC	ED555/2DS	CONNECTOR; FEMALE; THROUGH HOLE; TERMINAL BLOCK; RIGHT ANGLE; 2PINS	
12	JMP1	-	1	PEC04SAAN	SULLINS ELECTRONICS CORP.	PEC04SAAN	CONNECTOR; MALE; THROUGH HOLE; BREAKAWAY; STRAIGHT; 4PINS	
13	Q1	-	1	DMP6023LE	DIODES INCORPORATED	DMP6023LE	TRAN; 60V P-CHANNEL ENHANCEMENT MODE MOSFET; PCH; SOT223-4; PD-(2W); I(-7A); V(-60V)	
14	R1	-	1	CRCW040227K0FK	VISHAY DALE	27K	RESISTOR; 0402; 27KΩ; 1%; 100PPM; 0.0625W; THICK FILM	
15	R2	-	1	ERJ-2RKF5102	PANASONIC	51K	RESISTOR; 0402; 51KΩ; 1%; 100PPM; 0.1W; THICK FILM	
16	R3	-	1	MCR03EZPFX2002; ERJ-3EKF2002	ROHM; PANASONIC	20K	RESISTOR; 0603; 20KΩ; 1%; 100PPM; 0.10W; THICK FILM	
17	R4	-	1	CRCW0402220KFK; 9C04021A2203FLHF3	VISHAY DALE; YAGEO PHYCOMP	220K	RESISTOR; 0402; 220KΩ; 1%; 100PPM; 0.063W; THICK FILM	
18	R5	-	1	RC1005F2802	SAMSUNG ELECTRONICS	28K	RESISTOR; 0402; 28KΩ; 1%; 100PPM; 0.063W; THICK FILM	
19	R6, R7	-	2	CRCW06033K30FK	VISHAY DALE	3.3K	RESISTOR; 0603; 3.3KΩ; 1%; 100PPM; 0.10W; THICK FILM	
20	R8-R10	-	3	CRCW04021K00FK; RC0402FR-071KL	VISHAY DALE; YAGEO PHICOMP	1K	RESISTOR; 0402; 1K; 1%; 100PPM; 0.0625W; THICK FILM	
21	SU1-SU5	-	5	STC02SYAN	SULLINS ELECTRONICS CORP.	STC02SYAN	TEST POINT; JUMPER; STR; TOTAL LENGTH = 0.256IN; BLACK; INSULATION = PBT CONTACT = PHOSPHOR BRONZE; COPPER PLATED TIN OVERALL	
22	TP1, TP9	-	2	5010	KEYSTONE	N/A	TESTPOINT WITH 1.80MM HOLE DIA, RED, MULTIPURPOSE;	
23	TP2, TP4, TP12	-	3	5011	KEYSTONE	N/A	TEST POINT; PIN DIA = 0.125IN; TOTAL LENGTH = 0.445IN; BOARD HOLE=0.063IN; BLACK; PHOSPHOR BRONZE WIRE SILVER PLATE FINISH;	
24	TP3, TP5-TP8, TP10, TP13, TP14	-	8	5003	KEYSTONE	N/A	TEST POINT; PIN DIA = 0.1IN; TOTAL LENGTH = 0.3IN; BOARD HOLE = 0.04IN; ORANGE; PHOSPHOR BRONZE WIRE SILVER PLATE FINISH;	
25	TP11	-	1	5013	KEYSTONE	N/A	TEST POINT; PIN DIA = 0.125IN; TOTAL LENGTH = 0.445IN; BOARD HOLE = 0.063IN; ORANGE; PHOSPHOR BRONZE WIRE SILVER PLATE FINISH;	
26	TP15, TP16	-	2	6095	KEYSTONE	6095	CONNECTOR; FEMALE; PANELMOUNT; NON-INSULATED RECESSED HEAD BANANA JACK; STRAIGHT THROUGH; 1PIN	
27	U1	-	1	MAX14914ATE+	MAXIM	MAX14914ATE+	EVKIT PART - IC; SWITCH; HIGH-SIDE SWITCH WITH SETTABLE CURRENT LIMIT AND PUSH-PULL DRIVER OPTION; NO. OF LEADS-(16); TQFN16-EP	
28	J6, J8-J10	DNI	4	EVKIT_STANDOFF_4-40_3/8	?	EVKIT_STANDOFF_4-40_3/8	KIT; ASSY-STANDOFF 3/8IN; 1PC. STANDOFF/FEM/HEX4-40IN/(3/8IN)NYLON; 1PC. SCREW/SLOT/PAN/4-40IN/(3/8IN)NYLON	
29	C4	DNP	0	GRM32ER71J106KA12	MURATA	10UF	CAPACITOR; SMT (1210); CERAMIC CHIP; 10UF; 63V; TOL = 10%; TG = -55°C TO +125°C; TC = X7R	DNI
30	C6	DNP	0	C2012X7S2A105K125; GRJ21BC72A105KE11	TDK/MURATA	1UF	CAPACITOR; SMT (0805); CERAMIC CHIP; 1UF; 100V; TOL = 10%; TG=-55°C TO +125°C; TC = X7S	DNI
31	D3	DNP	0	SMBJ40CA	BOURNS	40V	DIODE; TVS; SMB (DO-214AA); VRM=40V; IPP = 9.3A	DNI
32	R11	DNP	0	CRCW0805150KFK	VISHAY DALE	150K	RESISTOR; 0805; 150K; 1%; 100PPM; 0.125W; THICK FILM	DNI
33	PCB	-	1	MAX14914	MAXIM	PCB	PCB Board:MAX14914 EVALUATION KIT	
TOTAL			55					

MAX14914 EV Kit PCB Layouts

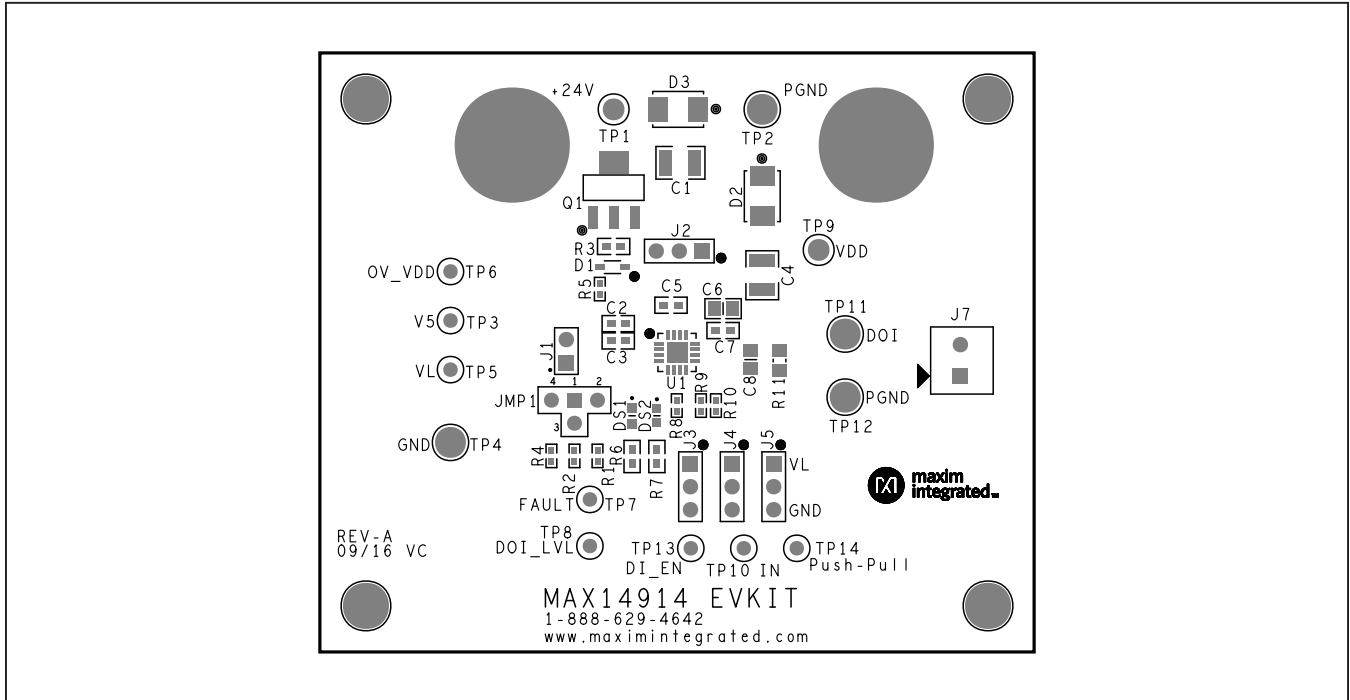

MAX14914 EV Kit—Top Silkscreen

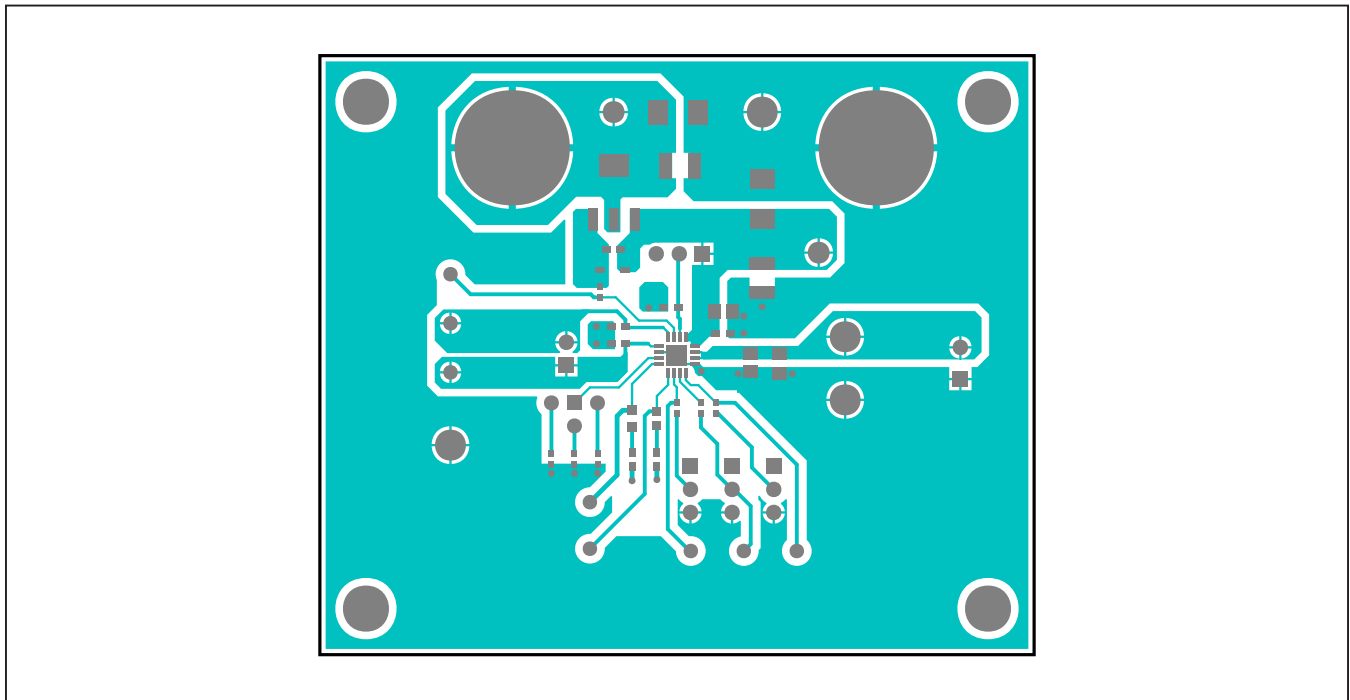

MAX14914 EV Kit—Top

MAX14914 EV Kit PCB Layouts (continued)

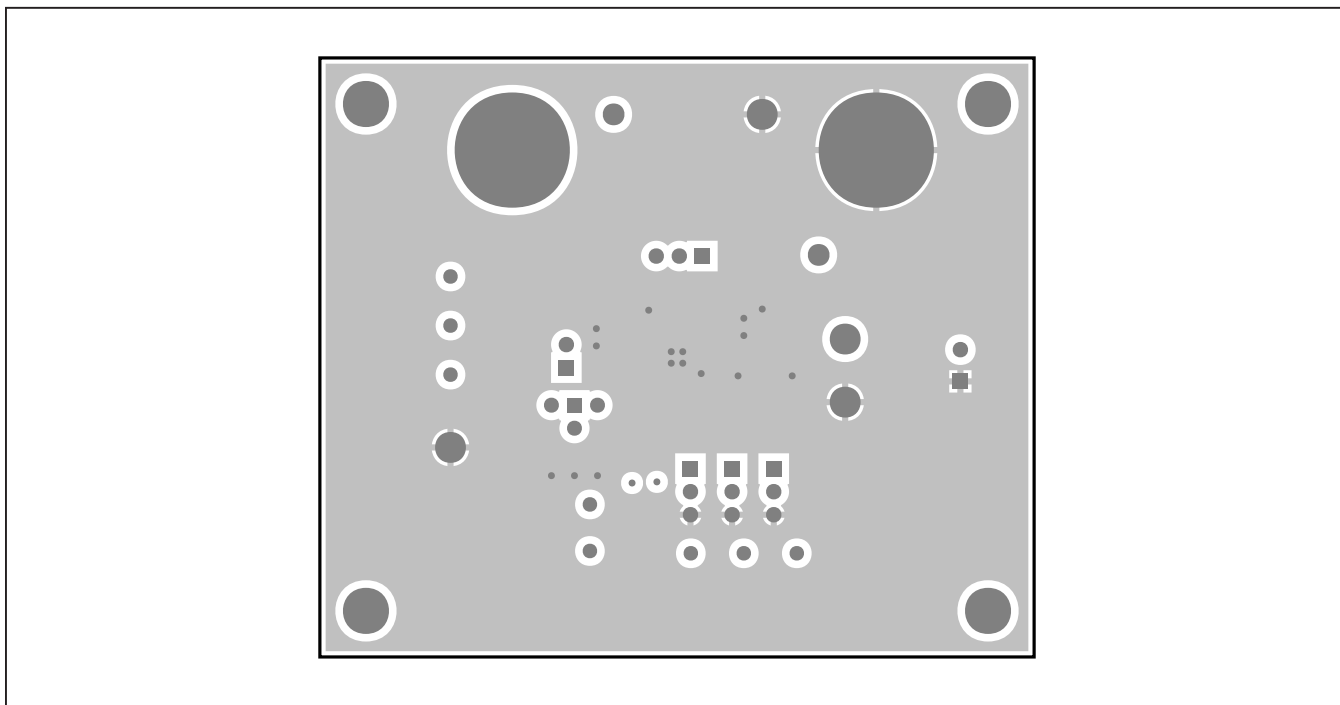

MAX14914 EV Kit—Level 2 GND

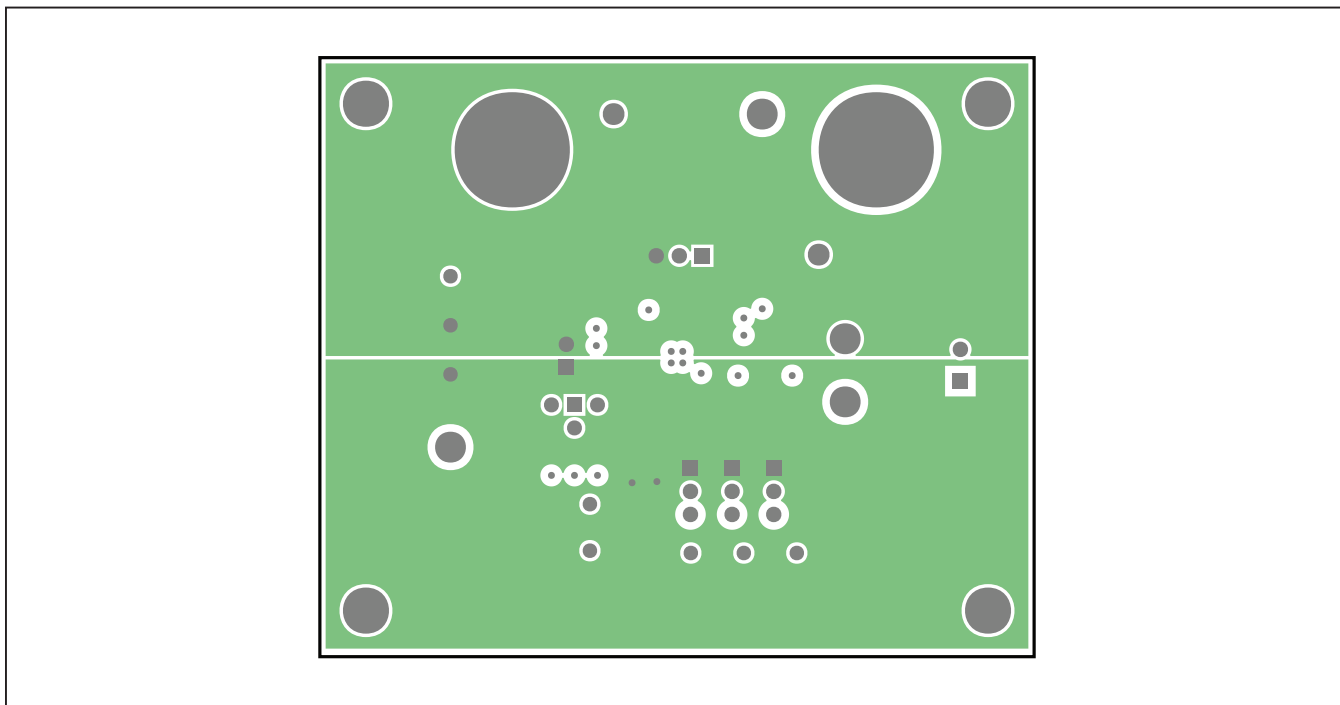

MAX14914 EV Kit—Level 3 Power

MAX14914 EV Kit PCB Layouts (continued)

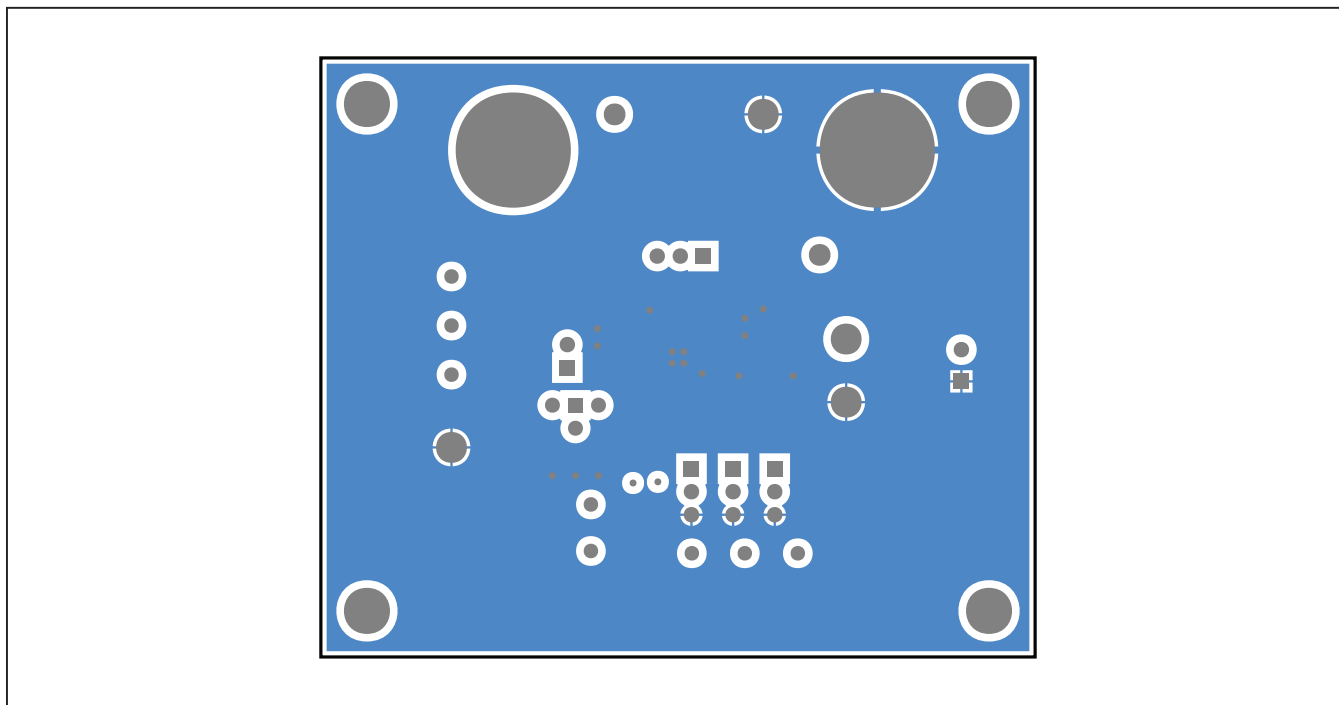

MAX14914 EV Kit—Bottom

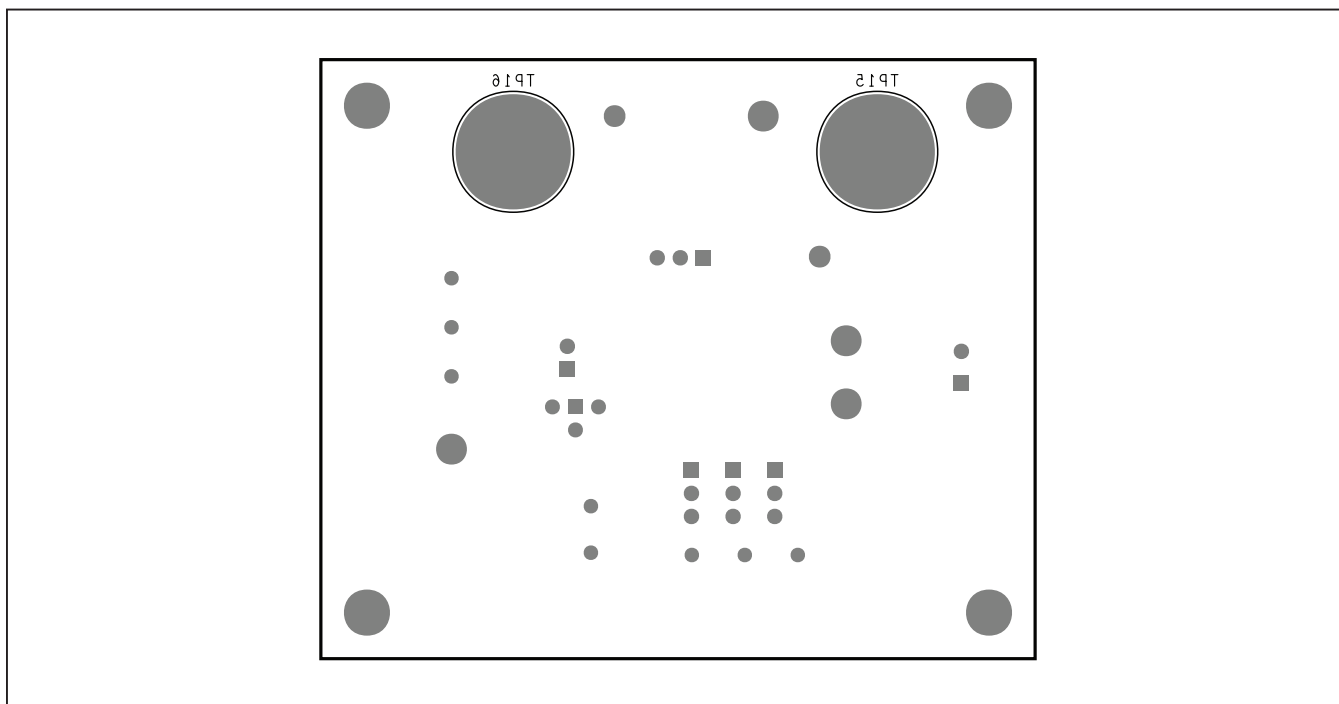

MAX14914 EV Kit—Bottom Silkscreen

Revision History

REVISION NUMBER	REVISION DATE	DESCRIPTION	PAGES CHANGED
0	2/17	Initial release	—
1	8/20	Updated the title and <i>General Description</i> section	1–10

For pricing, delivery, and ordering information, please visit Maxim Integrated's online storefront at <https://www.maximintegrated.com/en/storefront/storefront.html>.

Maxim Integrated cannot assume responsibility for use of any circuitry other than circuitry entirely embodied in a Maxim Integrated product. No circuit patent licenses are implied. Maxim Integrated reserves the right to change the circuitry and specifications without notice at any time.