

General Description

The MAX14826 evaluation kit (EV kit) consists of the evaluation board and software. The EV kit is a fully assembled and tested circuit board that evaluates the MAX14826 IO-Link® device transceiver.

The EV kit includes Windows XP®, Windows Vista®, and Windows® 7-compatible software that provides a graphical user interface (GUI) for exercising the features of the device. The EV kit is connected to a PC through a USB A-to-B cable.

Features

- IO-Link-Compliant Device Transceiver
- IO and SPI Interface Terminals
- Windows XP-, Windows Vista-, and Windows 7-Compatible Software
- USB-PC Connection (Cable Included)
- Proven PCB Layout
- Fully Assembled and Tested

MAX14826 EV Kit Files

FILE	DESCRIPTION
INSTALL.EXE	Installs the EV kit files on your computer
14826.EXE	Application program
CDM20600.EXE	Installs the USB device driver
UNINST.EXE	Uninstalls the EV kit software
USB_Driver_Help_200.PDF	USB driver installation help file

Ordering Information appears at end of data sheet.

IO-Link is a registered trademark of Profibus User Organization (PNO). Windows, Windows XP, and Windows Vista are registered trademarks and registered service marks of Microsoft Corporation.

Quick Start

Recommended Equipment

- MAX14826 EV kit (USB A-to-B cable included)
- User-supplied Windows XP, Windows Vista, or Windows 7 PC with a spare USB port
- 24V, 100mA DC power supply

Note: In the following sections, software-related items are identified by bolding. Text in **bold** refers to items directly from the EV kit software. Text in **bold and underlined** refers to items from the Windows operating system.

Procedure

The EV kit is fully assembled and tested. Follow the steps below to verify board operation before exercising the full features of the device:

- 1) Visit www.maximintegrated.com/evkitsoftware to download the latest version of the EV kit software, 14826Rxx.ZIP. Save the EV kit software to a temporary folder and uncompress the ZIP file.
- 2) Install the EV kit software and USB driver on your computer by running the INSTALL.EXE program inside the temporary folder. The program files are copied to your PC and icons are created in the Windows **Start | Programs** menu. During software installation, some versions of Windows may show a warning message indicating that this software is from an unknown publisher. This is not an error condition and it is safe to proceed with installation. Administrator privileges are required to install the USB device driver on Windows.
- 3) Verify that all the jumpers are in their default positions, as shown in [Table 1](#).
- 4) Connect the 24V DC power supply on the VCC and GND connectors on the EV kit board.
- 5) Connect the USB cable from the PC to the EV kit board. A Windows message appears when connecting the EV kit board to the PC for the first time. Each version of Windows has a slightly different message. If you see a Windows message stating **ready to use**, then proceed to the next step. Otherwise, open the USB_Driver_Help_200.PDF document in the Windows **Start | Programs** menu to verify that the USB driver was installed successfully.

- 6) Start the EV kit software by opening its icon in the Windows **Start | Programs** menu. The EV kit software main window appears, as shown in [Figure 1](#).
- 7) Verify that **Hardware: Connected** is displayed on the status bar at the bottom of the main window.
- 8) Press the **Read** or **Write** buttons on the GUI to access the device SPI registers.

Detailed Description of Software

Operating in SPI Mode

To operate the device through the SPI interface, using the on-board microcontroller, set JU9 to 1-2 and ensure that all shunts on JU10 are closed. JU11, JU12, JU13, and JU16 must be open in this mode.

Operating in Pin Mode

To operate the device in pin mode, set JU9 to 2-3 and ensure that all shunts on JU10 are open.

The main window of the evaluation software ([Figure 1](#)) displays the SPI registers and the device pins that are connected to the on-board MAXQ2000 microcontroller. The user can send read or write SPI commands to the device, configure the logic levels of the device input pins, and read back the logic levels of the device output pins.

To read an SPI register or an output pin logic level, press the **Read** button.

To configure an SPI register or an input pin logic level, first click on the desired radio button(s), and then press the **Write** button.

The software also automatically monitors the presence of the wake-up pulse on the WU/THSD pin and displays the result on the GUI.

The user can also change the SPI clock speed by clicking on the desired **SPI Clock Speed** radio button.

Advanced User Interface

There are two methods for communicating with the device. The first is through the window shown in [Figure 1](#). The second is through the **Advanced User Interface** window shown in [Figure 2](#). The **Advanced User Interface** window becomes available by selecting the **Options | Interface (Advanced User)** menu item and allows execution of serial commands manually.

The **Advanced User Interface** window can also be used as a debug tool because it is capable of manually reading and writing to every register and logic pin of the device.

Detailed Description of Hardware

The MAX14826 EV kit provides a proven layout for the MAX14826 IO-Link device transceiver.

All the power-supply and regulator input and output pins are connected to convenient connectors for easy probing. The device logic input and output pins are also provided with convenient connectors for logic testing.

The transceiver's C/Q, DO, and DI pins are protected by Semtech SDC36 TVS diodes.

See [Table 1](#) for a description of all the EV kit jumper configurations.

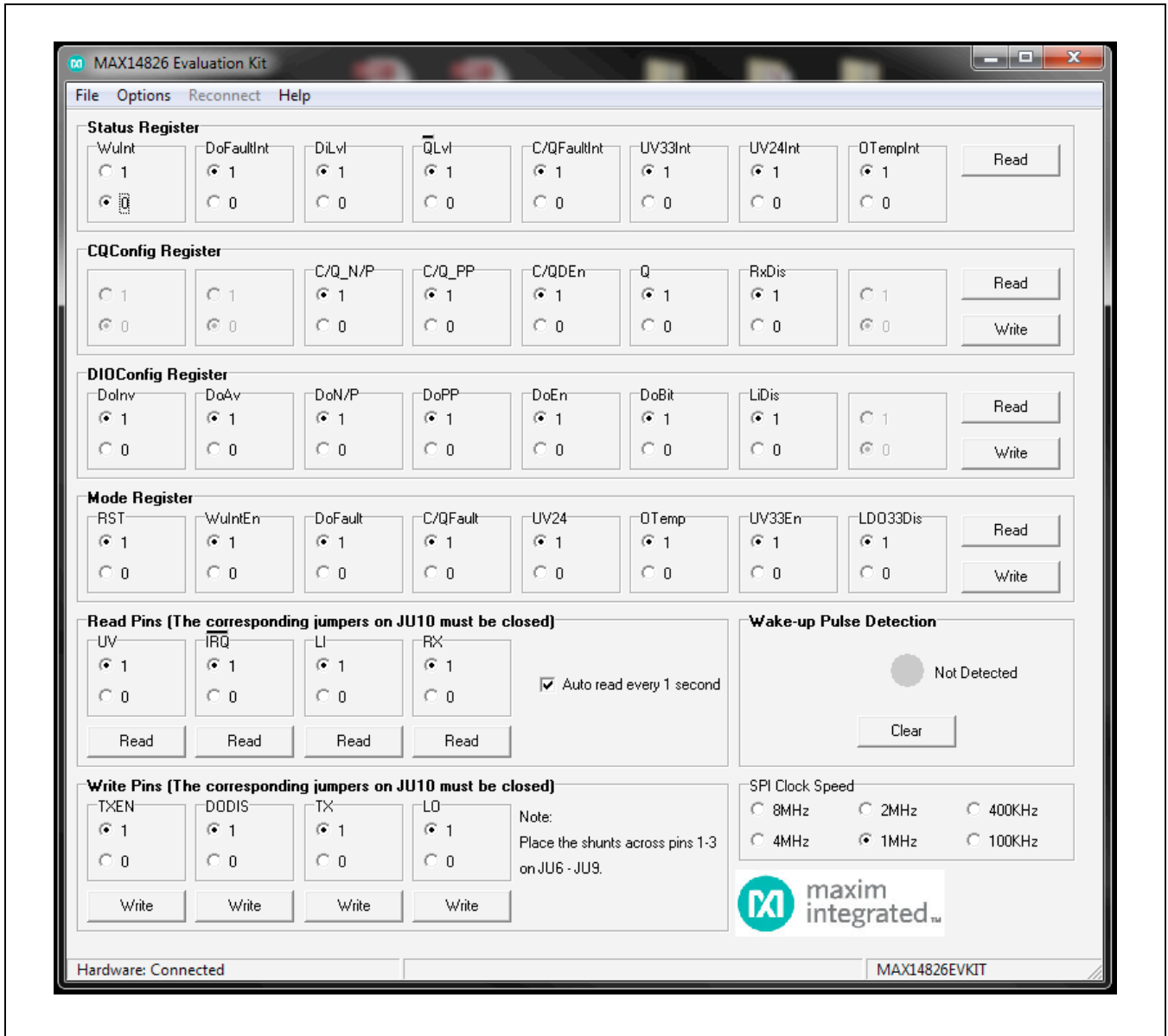

Figure 1. MAX14826 EV Kit Software Main Window

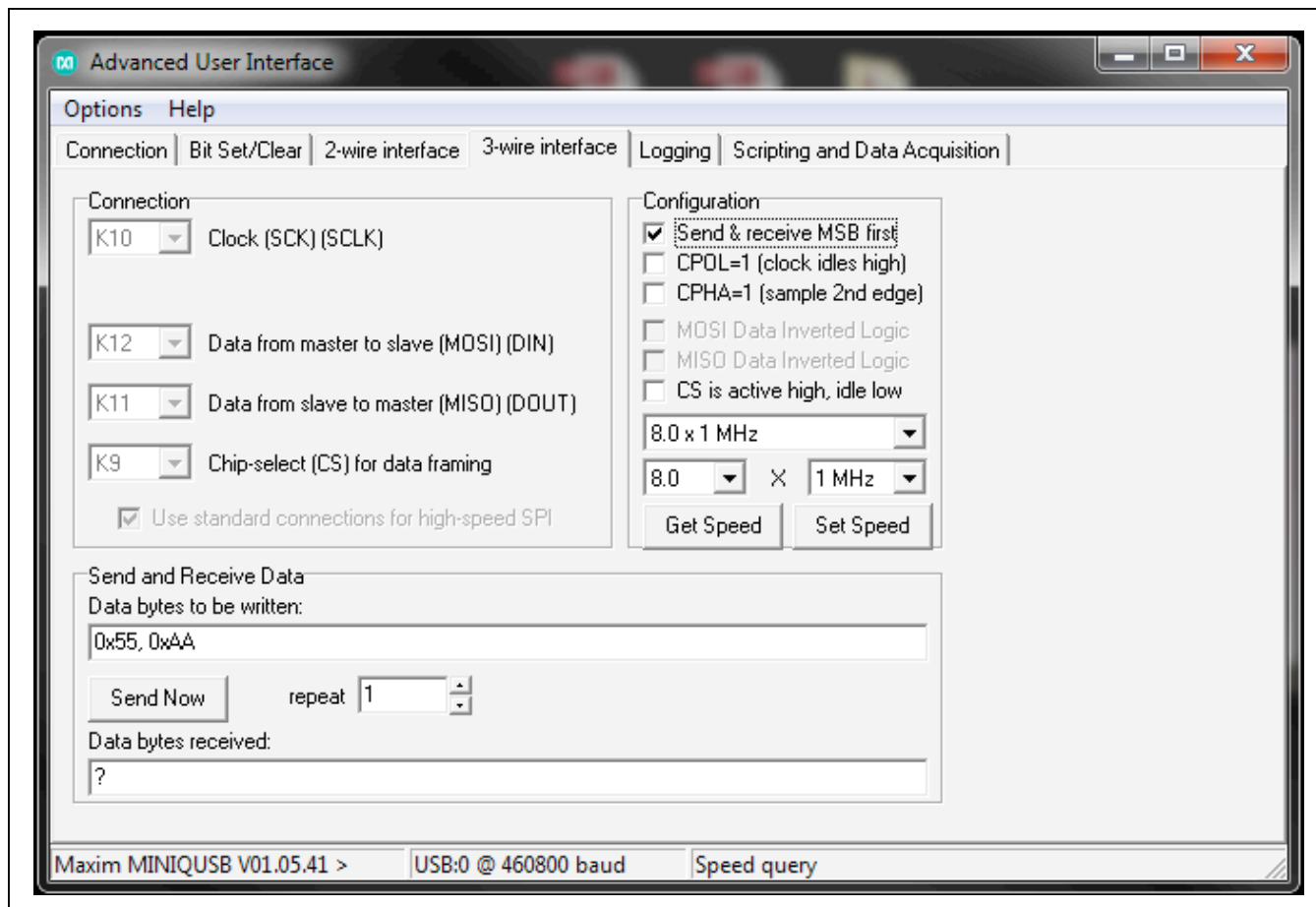

Figure 2. MAX14826 EV Kit Software Advanced User Interface Window

Table 1. Jumper Descriptions

JUMPER	SHUNT POSITON	DESCRIPTION
JU1	Closed*	Enables the C/Q LED indicator
	Open	Disables the C/Q LED indicator
JU2	Closed*	Enables the DO LED indicator
	Open	Disables the DO LED indicator
JU3	1-2*	Device is powered by the internal LDO
	2-3	Device is powered by external 5V connected on TP8
JU4	1-2*	Device VL is connected to LDO33
	2-3	Device VL is connected to V5
JU5	1-2*	TXEN pin is connected to VL
	2-3	TXEN pin is connected to GND
JU6	1-2*	DODIS pin is connected to VL
	2-3	DODIS pin is connected to GND
JU7	1-2*	TX pin is connected to VL
	2-3	TX pin is connected to GND
JU8	1-2*	LO pin is connected to VL
	2-3	LO pin is connected to GND
JU9	1-2	SPI/ $\overline{\text{PAR}}$ is connected to VL. Device is in SPI mode.
	2-3	SPI/ $\overline{\text{PAR}}$ is connected to GND. Device is in Pin Control mode.
JU10	1-2*	Device logic IO pins are connected to the on-board microcontroller.
	2-3	Device logic IO pins are disconnected from the on-board microcontroller.
JU11	1-2	SCLK/CQPP is connected to VL
	2-3	SCLK/CQPP is connected to GND
JU13	1-2	$\overline{\text{CS}}$ /PNP is connected to VL
	2-3	$\overline{\text{CS}}$ /PNP is connected to GND
JU14	Open	Enables the $\overline{\text{WU}}$ /THSD LED indicator
	Closed*	Disables the $\overline{\text{WU}}$ /THSD LED indicator
JU15	Open	Enables the $\overline{\text{IRQ}}$ /CQOC LED indicator
	Closed*	Disables the $\overline{\text{IRQ}}$ /CQOC LED indicator
JU16	Open	Enables the SDO/ $\overline{\text{DOOC}}$ LED indicator
	Closed*	Disables the SDO/ $\overline{\text{DOOC}}$ LED indicator
JU17	Open	Enables the DI LED indicator
	Closed*	Disables the DI LED indicator

*Default position.

Component Suppliers

SUPPLIER	WEBSITE
Hong Kong X'tals Ltd.	www.hongkongcrystal.com
Murata Americas	www.murata.com
Semtech Corporation	www.semtech.com

Note: Indicate that you are using the MAX14826 or MAX14821 when contacting these component suppliers.

Component List, PCB Files, and Schematics

See the following links for component information, PCB files and schematics:

- [MAX14826 EV BOM](#)
- [MAX14826 EV PCB Files](#)
- [MAX14826 EV Schematic](#)

Ordering Information

PART	TYPE
MAX14826EVKIT#	EV Kit

#Denotes RoHS compliant.

Revision History

REVISION NUMBER	REVISION DATE	DESCRIPTION	PAGES CHANGED
0	7/15	Initial release	—

For pricing, delivery, and ordering information, please contact Maxim Direct at 1-888-629-4642, or visit Maxim Integrated's website at www.maximintegrated.com.

Maxim Integrated cannot assume responsibility for use of any circuitry other than circuitry entirely embodied in a Maxim Integrated product. No circuit patent licenses are implied. Maxim Integrated reserves the right to change the circuitry and specifications without notice at any time.

Bill of Materials - DATE: 10/22/2014

ITEM	QTY	REF DES	Var Status	MAXINV	MFG PART #	MANUFACTURER	VALUE	DESCRIPTION
1	3	C1-C3	Pref	20-0470P-J0	FCP0805H471J-J1	Cornell Dubilier	470PF	CAPACITOR; SMT (0805); CERAMIC CHIP; 470PF; 50V; TOL=5%; MODEL=PPS; TG=-55 DEGC TO +125 DEGC; TC=+/-
2	2	C4,C6	Pref	20-0001U-04	GRM21BR71H105Ka12	Murata	1UF	CAPACITOR; SMT; 0805; CERAMIC; 1uF; 50V; 10%; X7R; -55degC to + 125degC; 0 +/-15% degC MAX.
3	12	C7,C8,C10,C15,C18-C24,C26	Pref	20-000U1-18	GRM188R61C104KA01	Murata	0.1UF	CAPACITOR; SMT (0603); CERAMIC CHIP; 0.1UF; 16V; TOL=10%; MODEL=; TG=-55 DEGC TO +125 DEGC; TC=X5R;
4	1	C9	Pref	20-0001U-18	GRM188R61C105K	Murata	1UF	CAPACITOR; SMT; 0603; CERAMIC; 1uF; 16V; 10%; X5R; -55degC to + 85degC; 0 +/-15% degC MAX.
5	1	C11	Pref	20-0U033-11	GRM188R71C333KA01	Murata	0.033UF	CAPACITOR; SMT (0603); CERAMIC CHIP; 0.033UF; 16V; TOL=10%; MODEL=GRM SERIES; TG=-55 DEGC TO +125 DEGC; TC=X7R
6	2	C12,C13	Pref	20-0010P-25	GRM18885C1H100JA01	Murata	10PF	CAPACITOR; SMT; 0603; CERAMIC; 10pF; 50V; 5%; COG; -55degC to + 125degC,
7	2	C14,C25	Pref	20-0010U-X3	GRM188R60J106ME47	Murata	10UF	CAPACITOR; SMT (0603); CERAMIC CHIP; 10UF; 6.3V; TOL=20%; MODEL=; TG=-55 DEGC TO +125 DEGC; TC=X5R
8	2	C16,C17	Pref	20-0022P-77	GRM39C0G220J50V	Murata	22PF	CAPACITOR; SMT (0603); CERAMIC CHIP; 22PF; 50V; TOL=5%; MODEL=; TG=-55 DEGC TO +125 DEGC; TC=COG
9	8	D1,D2,D4-D6,D11-D13	Pref	30-LGL29KG2J124Z-00	LGL29K-G2J1-24-Z	OSRAM	LGL29K-G2J1-24-Z	DIODE; LED; SMARTLED; GREEN; SMT; PIV=1.7V; IF=0.02A

10	3	D7-D9	Pref	30-SDC36CTC T-00	SDC36C.T CT	SEMTECH	SDC36C.T CT	DIODE; TVS; TVS DIODE ARRAY FOR PROXIMITY SWITCH INPUT PROTECTION; SMT (SOT-23); PIV=35V; IF=4A
11	1	FB1	Pref	50-00030- SM2	BLM18PG 300SN1D	MURATA	30	INDUCTOR; SMT (0603); FERRITE-BEAD; 30; TOL=+/-; 1.0A
12	1	J3	Pref	01- AUY1007R 4P-26	AU-Y1007- R	ASSMANN	AU-Y1007- R	CONNECTOR; FEMALE; THROUGH HOLE; USB B-TYPE CONNECTOR; RIGHT ANGLE; 4PINS; -55 DEGC TO +85 DEGC
13	6	JU1,JU2,JU1 4-JU17	Pref	01- PEC02SAA N2P-21	PEC02SAA N	SULLINS	PEC02SAA N	CONNECTOR; MALE; THROUGH HOLE; BREAKAWAY; STRAIGHT; 2PINS; -65 DEGC TO +125 DEGC
14	10	JU3- JU9,JU11- JU13	Pref	01- PEC03SAA N3P-21	PEC03SAA N	SULLINS	PEC03SAA N	CONNECTOR; MALE; THROUGH HOLE; BREAKAWAY; STRAIGHT; 3PINS; -65 DEGC TO +125 DEGC
15	1	JU10	Pref	01- 10897282 28P-21	10-89- 7282	MOLEX	10-89- 7282	CONNECTOR, TH, MALE, SALES ASSY-HIGH TEMP DUAL ROW WAFER WITH BREAK-OFF OPTION, 28PINS, STR
16	3	R1,R2,R8	Pref	80-0020K- 53	N/A	?	20K	RESISTOR; 0603; 20K OHM; 5%; 200PPM; 0.10W; METAL FILM
17	1	R3	Pref	80-0010R- 24	N/A	?	10	RESISTOR; 0603; 10 OHM; 1%; 100PPM; 0.10W; THICK FILM
18	6	R4,R6,R7,R1 0,R11,R17	Pref	80-001K5- 53	N/A	?	1.5K	RESISTOR; 0603; 1.5K OHM; 5%; 200PPM; 0.10W; METAL FILM
19	2	R5,R14	Pref	80-0010K- A4	N/A	?	10K	RESISTOR, 0603, 10K OHM, 5%, 200PPM, 1/16W, THICK FILM
20	1	R12	Pref	80-002K2- 53	N/A	?	2.2K	RESISTOR; 0603; 2.2K OHM; 5%; 200PPM; 0.10W; THICK FILM
21	1	R13	Pref	80-0470R- 53	N/A	?	470	RESISTOR; 0603; 470 OHM; 5%; 200PPM; 0.10W; METAL FILM
22	2	R15,R16	Pref	80-0000R- 27A	N/A	?	0	RESISTOR; 0603; 0 OHM; 5%; JUMPER; 0.10W; THICK FILM
23	2	R18,R19	Pref	80-0027R- 53	N/A	?	27	RESISTOR; 0603; 27 OHM; 5%; 200PPM; 0.10W; METAL FILM

24	1	R23	Pref	80-0001R-J1A	N/A	?	1	RESISTOR; 2010; 1 OHM; 1%; 100PPM; 1W; THICK FILM
25	23	SU1-SU14,SU19-SU27	Pref	02-JMPFSTC02SYAN-00	STC02SYAN	SULLINS ELECTRONICS CORP.	STC02SYAN	TEST POINT; JUMPER; STR; TOTAL LENGTH=0.256IN; BLACK; INSULATION=PBT CONTACT=PHOSPHOR BRONZE; COPPER PLATED TIN OVERALL
26	7	TP1,TP6-TP10,TP22	Pref	02-TPMINI5010-00	5010	Keystone	5010	TESTPOINT WITH 1.80MM HOLE DIA, RED, MULTIPURPOSE
27	3	TP2,TP11,TP21	Pref	02-TPMINI5011-00	5011	Keystone	5011	TEST POINT; PIN DIA=0.125IN; TOTAL LENGTH=0.445IN; BOARD HOLE=0.063IN; BLACK; PHOSPHOR BRONZE WIRE SILVER PLATE FINISH; RECOMMENDED FOR BOARD THICKNESS=0.062IN
28	12	TP3-TP5,TP12-TP20	Pref	02-TPMINI5014-00	5014	Keystone	5014	TEST POINT; PIN DIA=0.125IN; TOTAL LENGTH=0.445IN; BOARD HOLE=0.063IN; YELLOW; PHOSPHOR BRONZE WIRE SILVER PLATE FINISH; RECOMMENDED FOR BOARD THICKNESS=0.062IN
29	1	U1	Pref	MAX14826ETG+	MAX14826ETG+	MAXIM	MAX14826ETG+	IC; TXRX; IO-LINK DEVICE TRANSCEIVER; TQFN24-EP 4X4
30	1	U2	Pref	MAXQ2000-RAX+	MAXQ2000-RAX+	MAXIM	MAXQ2000-RAX	IC, CTRL, LOW-POWER LCD MICROCONTROLLER, QFN68
31	1	U3	Pref	MAX8511EXK25+	MAX8511EXK25+	MAXIM	MAX8511EXK25-T	IC; VREG; ULTRA-LOW-NOISE HIGH PSRR LOW-DROPOUT LINEAR REGULATOR; SC70-5 ; -40 DEGC TO +85 DEGC
32	1	U4	Pref	10-FT232BL-C	FT232BL	FTDI	FT232BL	IC, INFC, UART INTERFACE IC USB TO SERIAL, LQFP32 7X7
33	1	U5	Pref	10-AT93C46ENSHB-S	AT93C46EN-SH-B	ATMEL	AT93C46EN-SH-B	IC; EPROM; 3-WIRE SERIAL ELECTRICALLY ERASABLE PROGRAMABLE READ-ONLY MEMORY; NSOIC8 150MIL
34	1	U6	Pref	MAX8511EXK33+	MAX8511EXK33+	MAXIM	MAX8511EXK33	IC; VREG; ULTRA-LOW-NOISE, HIGH PSRR, LOW-DROPOUT, LINEAR REGULATOR; SC70-5 ; -40 DEGC TO +85 DEGC

35	1	Y1	Pref	60-0016M-12B	SSM16000 N1HK188F 0-0	HONG KONG CRYSTALS	16MHZ	CRYSTAL; SMT ; HC49US; 12PF; 16MHZ; +/-30PPM; +/-50PPM; -10 DEGC TO +60 DEGC
36	1	Y2	Pref	60-0006M-12A	SSL60000 N1HK188F 0-0	HONG KONG CRYSTALS	6MHZ	CRYSTAL; SMT ; 12PF; 6MHZ; +/-30PPM; +/-50PPM; -10 DEGC TO +60 DEGC
37	1		Pref	EPCB1482 6	EPCB1482 6	MAXIM	PCB	PCB: EPCB14826
TOTAL	128							

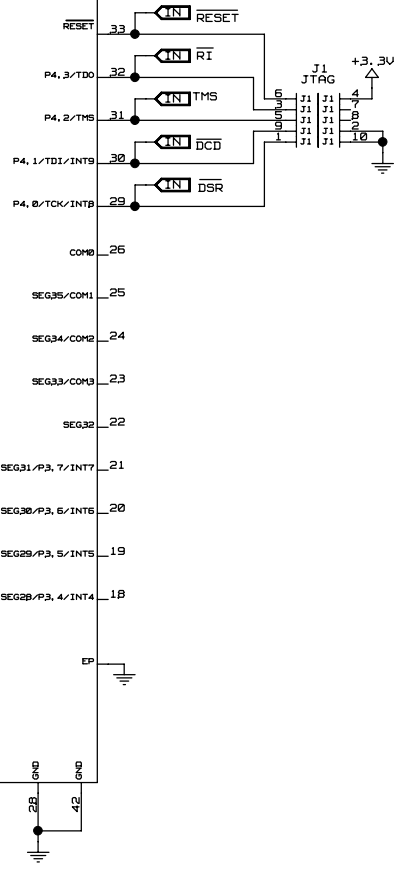
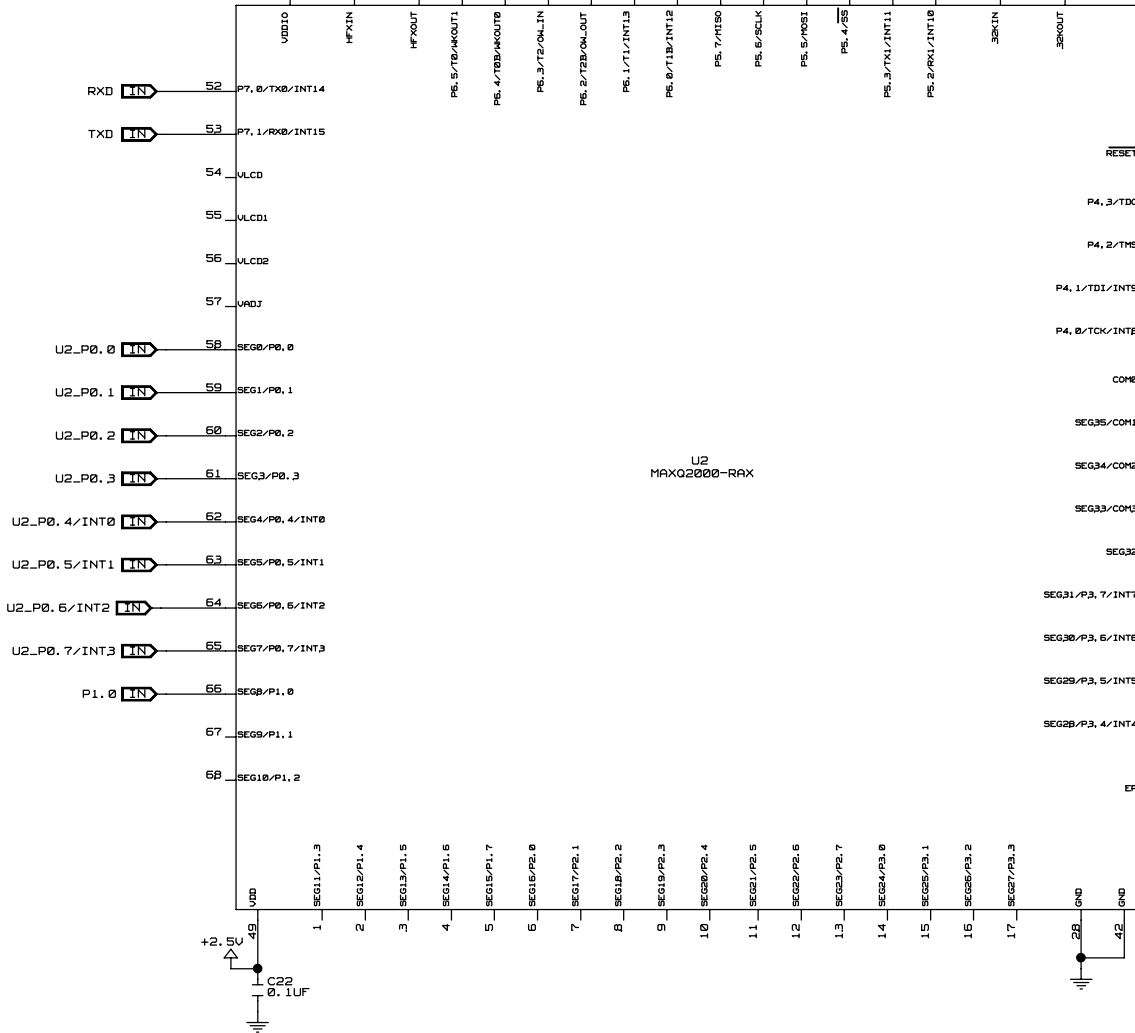
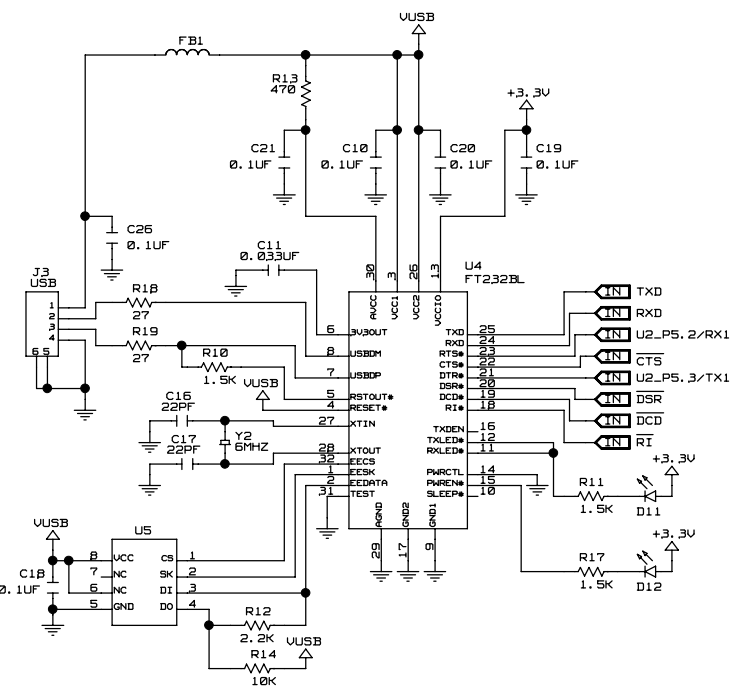
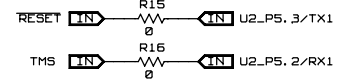
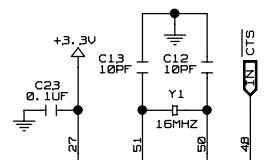
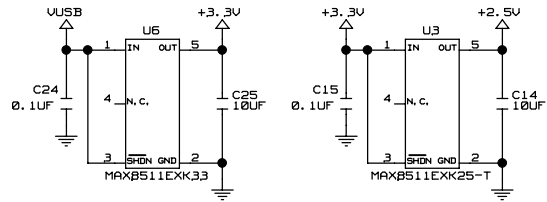

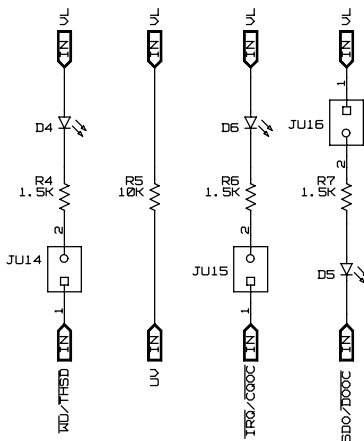

JU3	1-2*	USE INTERNAL 5V LDO
	2-3	USE EXTERNAL 5V APPLIED ON TP8

JU4	1-2*	VL=3.3V
	2-3	VL=5V

NOTE: *=DEFAULT POSITION

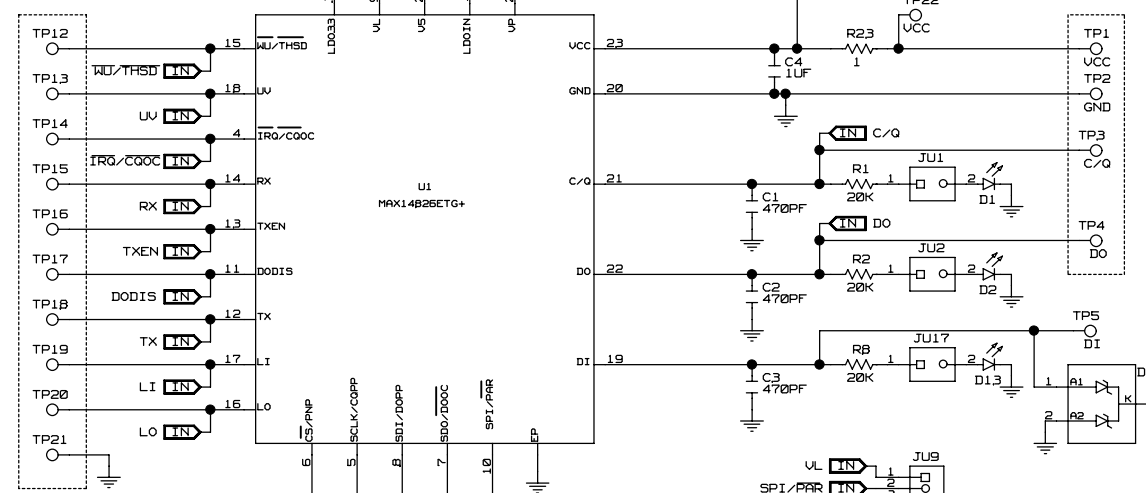
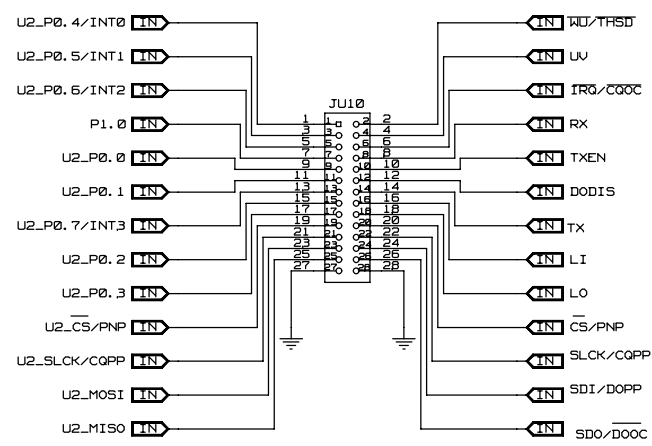
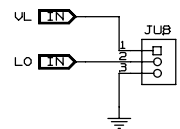
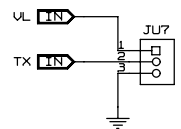
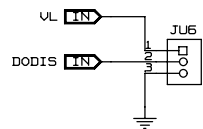
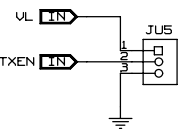
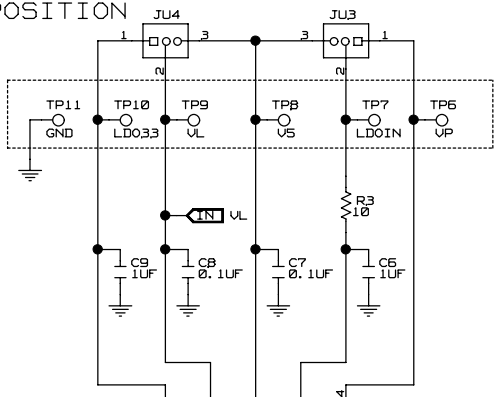

JU10	OPEN	MAX14826 LOGIC PINS DISCONNECTED FROM MAXQ2000
	CLOSED	MAX14826 LOGIC PINS CONNECTED TO MAXQ2000

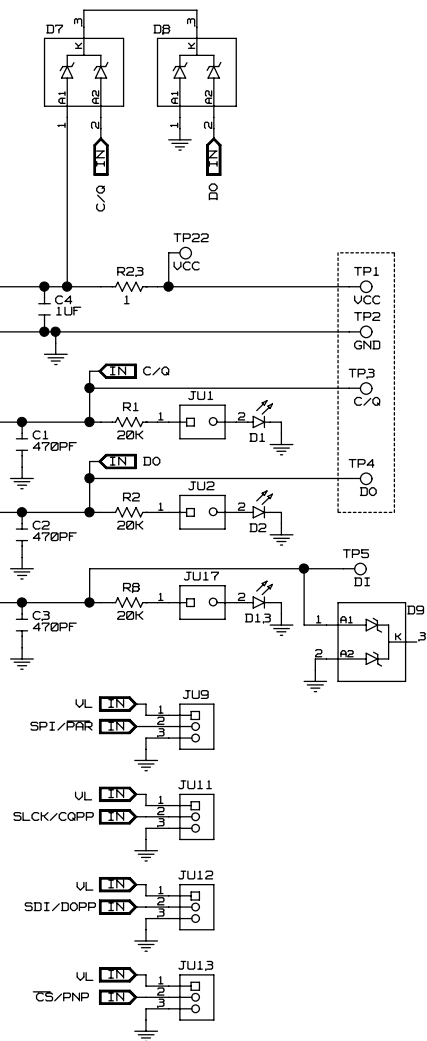



This document contains information considered proprietary, and shall not be reproduced wholly or in part, nor disclosed to others without specific written permission.

HARDWARE NAME: MAX14826_EVKIT_A

HARDWARE NUMBER:

ENGINEER:

DESIGNER:

DATE: 10/15/2014

ODB++/GERBER: BOTTOM

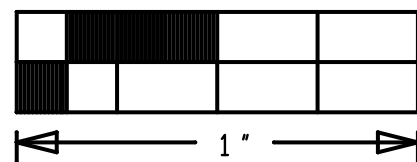
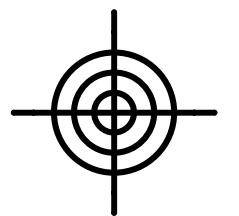
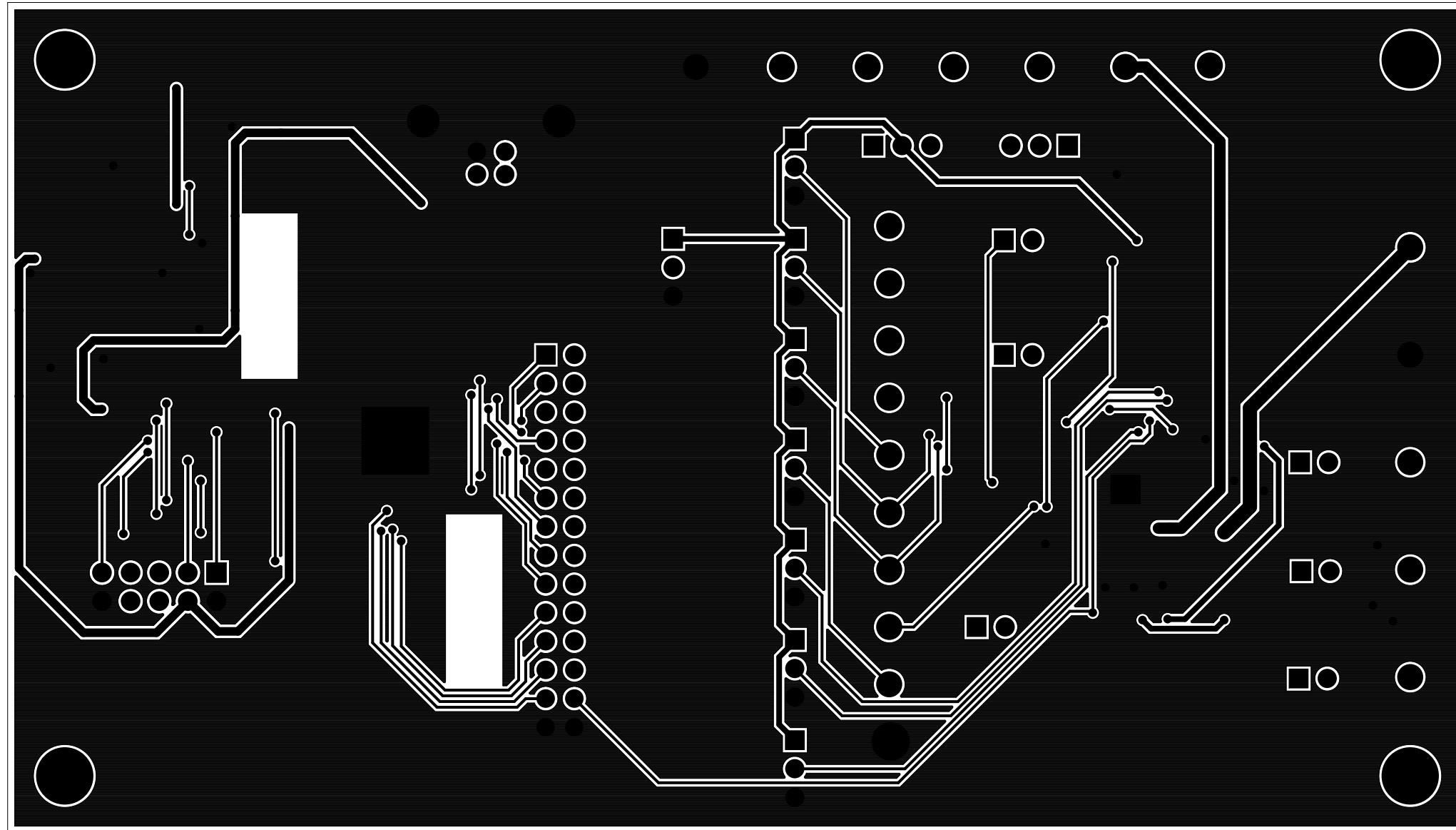
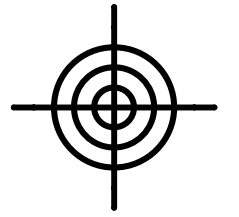
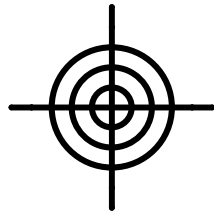



This document contains information considered proprietary, and shall not be reproduced wholly or in part, nor disclosed to others without specific written permission.

HARDWARE NAME: MAX14826_EVKIT_A

HARDWARE NUMBER:

ENGINEER:

DESIGNER:

DATE: 10/15/2014

ODB++/GERBER: TOP

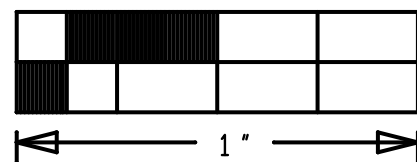
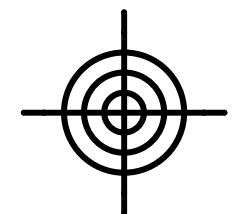
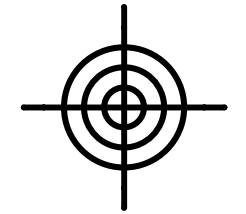
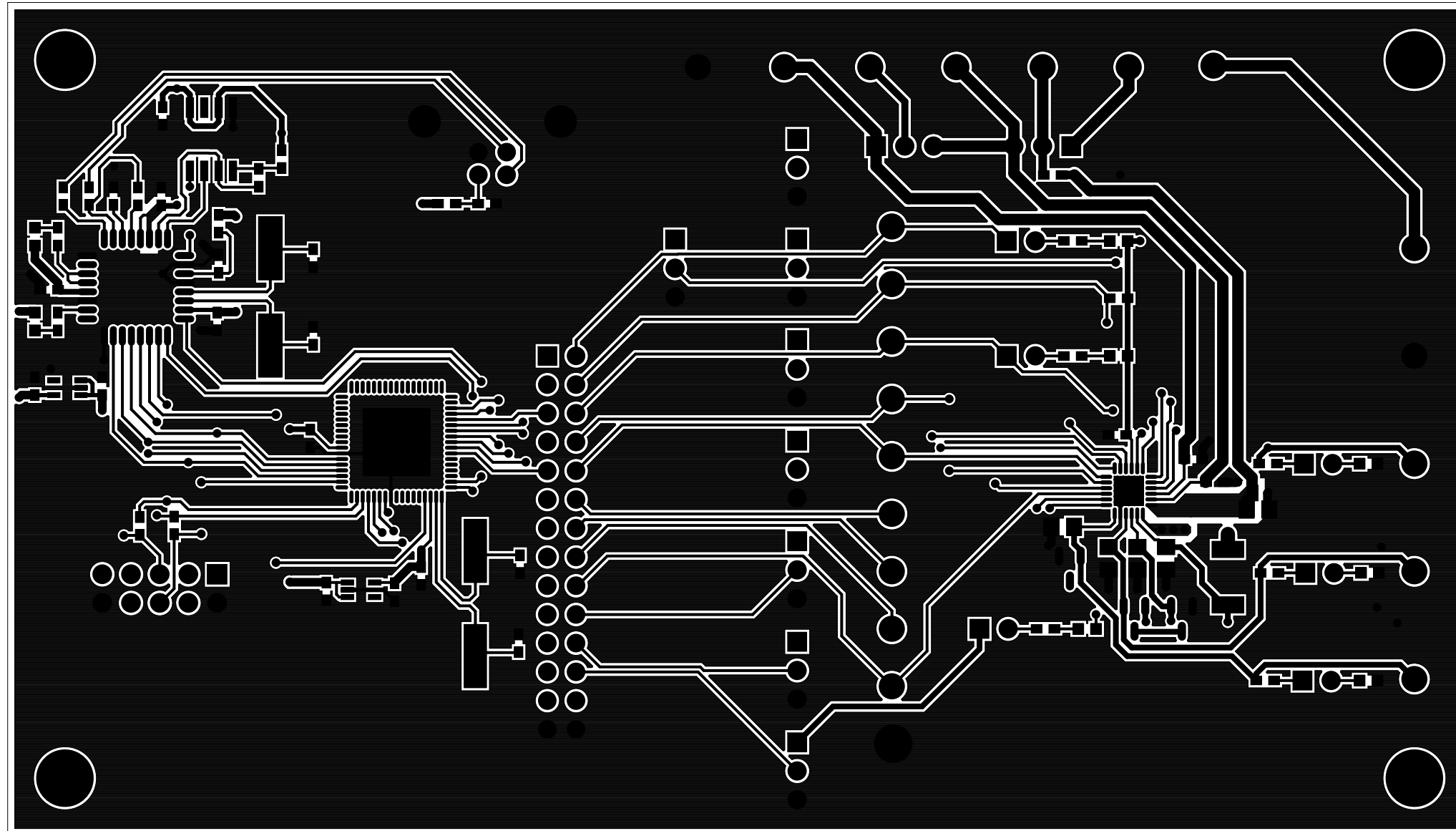
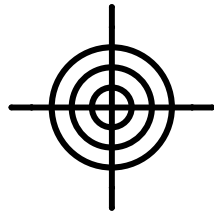



This document contains information considered proprietary, and shall not be reproduced wholly or in part, nor disclosed to others without specific written permission.

HARDWARE NAME: MAX14826_EVKIT_A

HARDWARE NUMBER:

ENGINEER:

DESIGNER:

DATE: 10/15/2014

ODB++/GERBER: SILK_TOP

