



±80V Fault-Protected Full-Duplex RS-485 Transceiver

MAX13448E

General Description

The MAX13448E full-duplex RS-485 transceiver features inputs and outputs fault protected up to ±80V (with respect to ground). The device operates from a +3.0V to +5.5V supply and features true fail-safe circuitry, guaranteeing a logic-high receiver output when the receiver inputs are open or shorted. This enables all receiver outputs on a terminated bus to output logic-high when all transmitters are disabled.

The MAX13448E features a slew-rate limited driver that minimizes EMI and reduces reflections caused by improperly terminated cables, allowing error-free data transmission at data rates up to 500kbps with a +5V supply, and 250kbps with a +3.3V supply.

The MAX13448E includes a hot-swap capability to eliminate false transitions on the bus during power-up or hot insertion. The driver and receiver feature active-high and active-low enables, respectively, that can be connected together externally to serve as a direction control.

The MAX13448E features an 1/8-unit load receiver input impedance, allowing up to 256 transceivers on the bus. All driver outputs are protected to ±8kV ESD using the Human Body Model. The MAX13448E is available in a 14-pin SO package and operates over the extended -40°C to +85°C temperature range.

Applications

Industrial Control Systems
HVAC Control systems
Utility Meters
Motor Driver Control Systems

Features

- ◆ ±80V Fault Protection on the RS-485 I/O Ports
- ◆ True Fail-Safe Receiver
- ◆ Hot-Swap Input Structure on DE
- ◆ ESD Protection on the RS-485 I/O Ports
±8kV Human Body Model
- ◆ Slew-Rate Limiting Facilitates Error-Free Data Transmission
- ◆ 1/8-Unit Load Allows Up to 256 Transceivers on the Bus
- ◆ -7V to +12V Common-Mode Input Voltage Range
- ◆ +3.0V to +5.5V Operating Supply Voltage
- ◆ Available in 14-Pin SO Package

Ordering Information

PART	TEMP RANGE	PIN-PACKAGE
MAX13448EEESD+	-40°C to +85°C	14 SO

+Denotes a lead-free package.

Pin Configuration appears at end of data sheet.

Functional Diagram

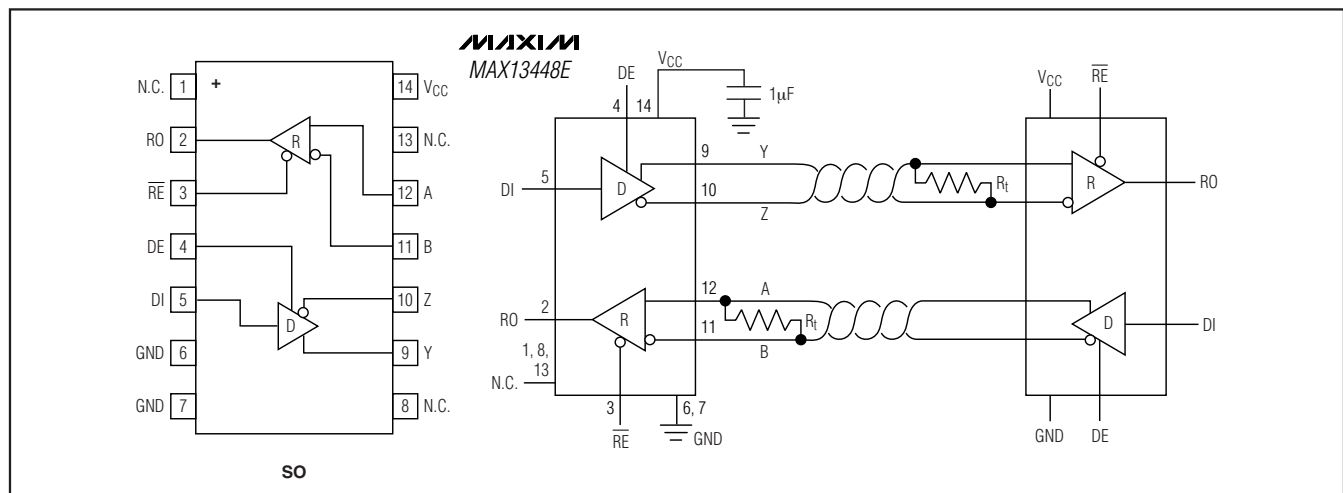

±80V Fault-Protected Full-Duplex RS-485 Transceiver

ABSOLUTE MAXIMUM RATINGS

(All voltages reference to GND.)

Supply Voltage (V _{CC})	+6V
Control Input Voltage (\overline{RE} , DE)	-0.3V to (V _{CC} + 0.3V)
Driver Input Voltage (DI)	-0.3V to (V _{CC} + 0.3V)
Receiver Input Voltage (A, B (Note 1))	±80V
Driver Output Voltage (Y, Z (Note 1))	±80V
Receiver Output Voltage (RO)	-0.3V to (V _{CC} + 0.3V)
Short-Circuit Duration (RO, A, B)	Continuous

Continuous Power Dissipation (T_A = +70°C)

14-Pin SO (derate 8.3mW/°C above +70°C)	667mW
Operating Temperature Range	-40°C to +85°C
Junction Temperature	+150°C
Storage Temperature Range	-65°C to +150°C
Lead Temperature (soldering, 10s)	+300°C

Note 1: If the RS-485 transmission lines are unterminated and a short to a voltage V_{SHT} occurs at a remote point on the line, an active local driver (with DI switching) may see higher voltage than V_{SHT} due to inductive kickback at the driver. Terminating the line with a resistor equal to its characteristic impedance minimizes this kickback effect.

Stresses beyond those listed under "Absolute Maximum Ratings" may cause permanent damage to the device. These are stress ratings only, and functional operation of the device at these or any other conditions beyond those indicated in the operational sections of the specifications is not implied. Exposure to absolute maximum rating conditions for extended periods may affect device reliability.

ELECTRICAL CHARACTERISTICS

(V_{CC} = +3.0 to +5.5V, T_A = T_{MIN} to T_{MAX}, unless otherwise noted. Typical values are at V_{CC} = +3.3V and T_A = +25°C.) (Notes 2, 3)

PARAMETER	SYMBOL	CONDITION	MIN	TYP	MAX	UNITS
V _{CC} Supply Voltage Range	V _{CC}		3.0		5.5	V
Supply Current	I _Q	No load, DE, DI, \overline{RE} = 0V or V _{CC} , V _{CC} = 3.3V			15	mA
		No load, DE, DI, \overline{RE} = 0V or V _{CC} , V _{CC} = 5V			15	
Supply Current in Shutdown Mode	I _{SHDN}	DE = GND, \overline{RE} = V _{CC} , V _{CC} = 3.3V			100	μA
		DE = GND, \overline{RE} = V _{CC} , V _{CC} = 5V			100	
Supply Current with Output Shorted to ±60V	I _{SHRT}	DE = GND, \overline{RE} = GND, short to +60V			15	mA
		DE = GND, \overline{RE} = GND, short to -60V			15	
DRIVER						
Differential Driver Output	V _{OD}	R _L = 100Ω, Figure 1	2		V _{CC}	V
		R _L = 54Ω, Figure 1	1.5		V _{CC}	
Change in Magnitude of Differential Output Voltage	ΔV _{OD}	R _L = 100Ω or 54Ω, Figure 1 (Note 4)	-0.2		0.2	V
Driver Common-Mode Output Voltage	V _{OC}	R _L = 100Ω or 54Ω, Figure 1		V _{CC} /2	3	V
Change in Magnitude of Common-Mode Voltage	ΔV _{OC}	R _L = 100Ω or 54Ω, Figure 1 (Note 4)	-0.2		+0.2	V
Driver Short-Circuit Output Current	I _{OSD}	DI = low, 0V ≤ V _Y or V _Z ≤ +12V			+250	mA
		DI = high, -7V ≤ V _Y or V _Z ≤ V _{CC} (Note 5)	-250			
Driver Short-Circuit Foldback Output Current	I _{OSDF}	DI = low, (V _{CC} - 1V) ≤ V _Y or V _Z ≤ +12V	+10			mA
		DI = high, -7V ≤ V _Y or V _Z ≤ +1V			-10	
Driver-Limit Short-Circuit Foldback Output Current	I _{OSDL}	V _Y or V _Z ≥ +22V, R _L = 100Ω			+6	mA
		V _Y or V _Z ≤ -13V, R _L = 100Ω	-6			
Driver Input High Voltage	V _{DIH}		2			V
Driver Input Low Voltage	V _{DIL}				0.8	V
Driver Input Current	I _{DIN}		-1		+1	μA

±80V Fault-Protected Full-Duplex RS-485 Transceiver

MAX13448E

ELECTRICAL CHARACTERISTICS (continued)

($V_{CC} = +3.0$ to $+5.5V$, $T_A = T_{MIN}$ to T_{MAX} , unless otherwise noted. Typical values are at $V_{CC} = +3.3V$ and $T_A = +25^\circ C$.) (Notes 2, 3)

PARAMETER	SYMBOL	CONDITION	MIN	TYP	MAX	UNITS
RECEIVER						
Input Current	$I_{A, B}$	$V_A, V_B = +12V$ $V_{CC} = GND$ or $V_{CC} = +3.0V$ to $+5.5V$			+125	μA
		$V_A, V_B = -7V$	-100			μA
		$V_A, V_B = \pm 80V$	-6		+6	mA
Receiver Differential Threshold Voltage	V_{TH}	$-7V \leq V_{CM} \leq +12V$	-200		-50	mV
Receiver Input Hysteresis	ΔV_{TH}			25		mV
Output High Voltage	V_{OH}	$I_{OH} = -1.6mA$	$V_{CC} - 0.6$			V
Output Low Voltage	V_{OL}	$I_{OL} = 1mA$			0.4	V
Three-State Output Current at Receiver	I_{OZR}	$0 \leq V_A, V_B \leq V_{CC}$	-1		+1	μA
Receiver Output Short-Circuit Current	I_{OSR}	$0 \leq V_{RO} \leq V_{CC}$	-95		+95	mA
ESD PROTECTION						
All Pins		Human Body Model		± 2		kV
ESD Protection Level (A and B, Y and Z)		Human Body Model		± 8		kV
CONTROL						
Control Input High Voltage	V_{CIH}	DE, \overline{RE}	2			V
Control Input Low Voltage	V_{CIL}	DE, \overline{RE}			0.8	V
Input Current Latch During First Rising Edge	I_{IN}	DE, \overline{RE}		80		μA
PROTECTION SPECIFICATIONS						
Overvoltage Protection		A, B, Y, Z	-80		+80	V

SWITCHING CHARACTERISTICS ($V_{CC} = +3.3V \pm 10\%$)

($T_A = T_{MIN}$ to T_{MAX} , unless otherwise noted. Typical values are at $V_{CC} = +3.3V$ and $T_A = +25^\circ C$.)

PARAMETER	SYMBOL	CONDITION	MIN	TYP	MAX	UNITS
DRIVER						
Driver Differential Propagation Delay	t_{DPLH}, t_{DPHL}	$R_L = 54\Omega, C_L = 50pF$, Figures 2 and 3		700	1500	ns
Driver Differential Output Transition Time	t_{LH}, t_{HL}	$R_L = 54\Omega, C_L = 50pF$, Figures 2 and 3	250		1200	ns
Differential Driver Output Skew	t_{DSKEW}	$R_L = 54\Omega, C_L = 50pF, t_{DSKEW} = [t_{DPLH} - t_{DPHL}]$, Figures 2 and 3		150	200	ns
Maximum Data Rate	f_{MAX}		250			kbps
Driver Enable Time to Output High	t_{DZH}	$R_L = 500\Omega, C_L = 50pF$, Figure 4			2000	ns

±80V Fault-Protected Full-Duplex RS-485 Transceiver

SWITCHING CHARACTERISTICS (V_{CC} = +3.3V ±10%) (continued)

(T_A = T_{MIN} to T_{MAX}, unless otherwise noted. Typical values are at V_{CC} = +3.3V and T_A = +25°C.)

PARAMETER	SYMBOL	CONDITION	MIN	TYP	MAX	UNITS
Driver Disable Time from Output High	t _{DHZ}	R _L = 500Ω, C _L = 50pF, Figure 4			1000	ns
Driver Enable Time from Shutdown to Output High	t _{DZH(SHDN)}	R _L = 500Ω, C _L = 50pF, Figure 4			8	μs
Driver Enable Time to Output Low	t _{DZL}	R _L = 500Ω, C _L = 50pF, Figure 5			1500	ns
Driver Disable Time from Output Low	t _{DLZ}	R _L = 500Ω, C _L = 50pF, Figure 5			2000	ns
Driver Enable Time from Shutdown to Output Low	t _{DZL(SHDN)}	R _L = 500Ω, C _L = 50pF, Figure 5			8	μs
Driver Time to Shutdown	t _{SHDN}	R _L = 500Ω, C _L = 50pF			12	μs
RECEIVER						
Receiver Propagation Delay	t _{RPLH} , t _{RPHL}	C _L = 20pF, V _{ID} = 2V, V _{CM} = 0V, Figure 6			2000	ns
Receiver Output Skew	t _{RSKEW}	C _L = 20pF, t _{RSKEW} = [t _{RPLH} - t _{RPHL}], Figure 6			200	ns
Receiver Enable Time to Output High	t _{RZH}	R _L = 1kΩ, C _L = 20pF, Figure 7			1000	ns
Receiver Disable Time from Output High	t _{RHZ}	R _L = 1kΩ, C _L = 20pF, Figure 7			150	ns
Receiver Wake Time from Shutdown	t _{RWAKE}	R _L = 1kΩ, C _L = 20pF, Figure 7			5	μs
Receiver Enable Time to Output Low	t _{RZL}	R _L = 1kΩ, C _L = 20pF, Figure 7			1000	ns
Receiver Disable Time from Output Low	t _{RLZ}	R _L = 1kΩ, C _L = 20pF, Figure 7			150	ns
Receiver Time to Shutdown	t _{SHDN}	R _L = 500Ω, C _L = 50pF			200	ns

SWITCHING CHARACTERISTICS (V_{CC} = +5V ±10%)

(T_A = T_{MIN} to T_{MAX}, unless otherwise noted. Typical values are at V_{CC} = +5V and T_A = +25°C.)

PARAMETER	SYMBOL	CONDITION	MIN	TYP	MAX	UNITS
DRIVER						
Driver Differential Propagation Delay	t _{DPLH} , t _{DPHL}	R _L = 54Ω, C _L = 50pF, Figure 3			800	ns
Driver Differential Output Transition Time	t _{LH} , t _{HL}	R _L = 54Ω, C _L = 50pF, Figure 3	100		1200	ns
Differential Driver Output Skew	t _{DSKEW}	R _L = 54Ω, C _L = 50pF, t _{DSKEW} = [t _{DPLH} - t _{DPHL}], Figure 3			200	ns
Maximum Data Rate	f _{MAX}		500			kbps

±80V Fault-Protected Full-Duplex RS-485 Transceiver

MAX13448E

SWITCHING CHARACTERISTICS (V_{CC} = +5V ±10%) (continued)

(T_A = T_{MIN} to T_{MAX}, unless otherwise noted. Typical values are at V_{CC} = +5V and T_A = +25°C.)

PARAMETER	SYMBOL	CONDITION	MIN	TYP	MAX	UNITS
Driver Enable Time to Output High	t _{DZH}	R _L = 500Ω, C _L = 50pF, Figure 4			1500	ns
Driver Disable Time from Output High	t _{DHZ}	R _L = 500Ω, C _L = 50pF, Figure 4			1000	ns
Driver Enable Time from Shutdown to Output High	t _{DZH(SHDN)}	R _L = 500Ω, C _L = 50pF, Figure 4			8	μs
Driver Enable Time to Output Low	t _{DZL}	R _L = 500Ω, C _L = 50pF, Figure 5			1000	ns
Driver Disable Time from Output Low	t _{DLZ}	R _L = 500Ω, C _L = 50pF, Figure 5			2	μs
Driver Enable Time from Shutdown to Output Low	t _{DZL(SHDN)}	R _L = 500Ω, C _L = 50pF, Figure 5			8	μs
Driver Time to Shutdown	t _{SHDN}	R _L = 500Ω, C _L = 50pF			12	μs
RECEIVER						
Receiver Propagation Delay	t _{RPLH} , t _{RPHL}	C _L = 20pF, V _{ID} = 2V, V _{CM} = 0V, Figure 6			2000	ns
Receiver Output Skew	t _{RSKEW}	C _L = 20pF, t _{RSKEW} = [t _{RPLH} - t _{RPHL}], Figure 6			200	ns
Receiver Enable Time to Output High	t _{RZH}	R _L = 1kΩ, C _L = 20pF, Figure 7			1000	ns
Receiver Disable Time from Output High	t _{RHZ}	R _L = 1kΩ, C _L = 20pF, Figure 7			150	ns
Receiver Wake Time from Shutdown	t _{RWAKE}	R _L = 1kΩ, C _L = 20pF, Figure 7			8	μs
Receiver Enable Time to Output Low	t _{RZL}	R _L = 1kΩ, C _L = 20pF, Figure 7			1000	ns
Receiver Disable Time from Output Low	t _{RLZ}	R _L = 1kΩ, C _L = 20pF, Figure 7			150	ns
Receiver Time to Shutdown	t _{SHDN}	R _L = 500Ω, C _L = 50pF			150	ns

Note 2: Parameters are 100% production tested at T_A = +25°C, unless otherwise noted. Limits over temperature are guaranteed by design.

Note 3: All currents into the device are positive. All currents out of the device are negative. All voltages are referenced to device ground, unless otherwise noted.

Note 4: ΔV_{OD} and ΔV_{OC} are the changes in V_{OD} and V_{OC}, respectively, when the DI input changes state.

Note 5: The short-circuit output current applies to peak current just prior to foldback current limiting. The short-circuit foldback output current applies during current limiting to allow a recover from bus contention.

±80V Fault-Protected Full-Duplex RS-485 Transceiver

Typical Operating Characteristics

($V_{CC} = +3.3V$, $T_A = +25^\circ C$, unless otherwise noted.)

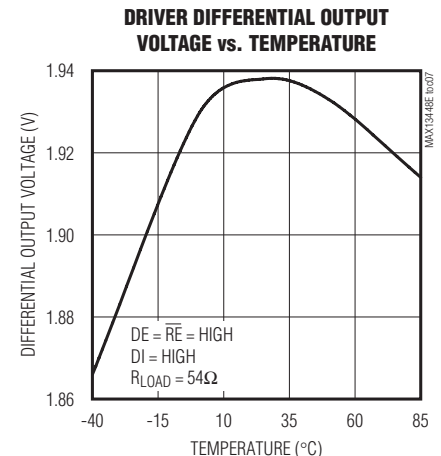
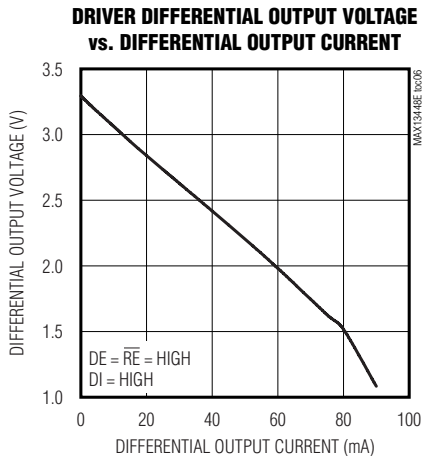
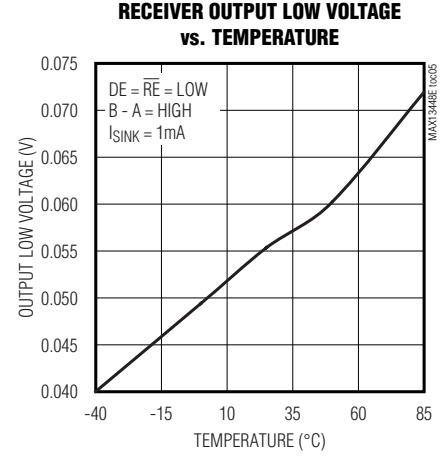
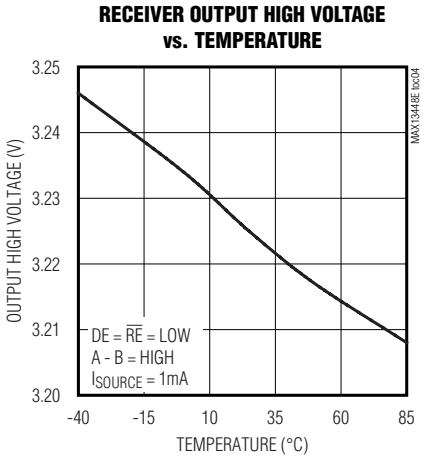
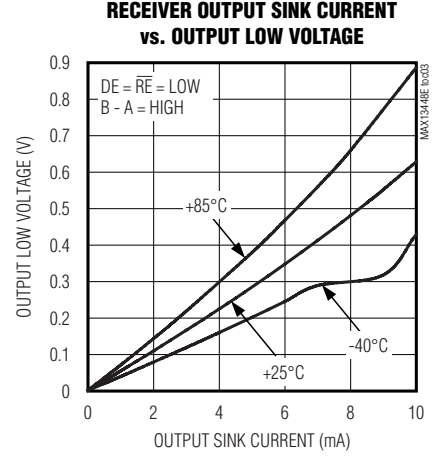
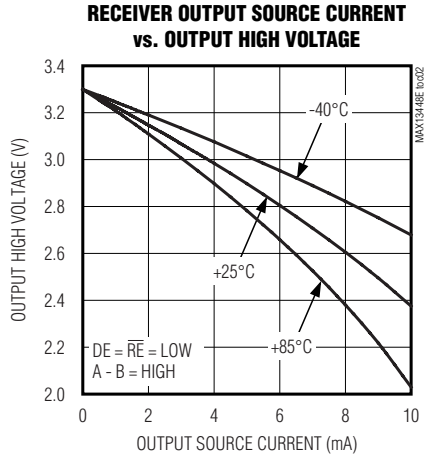
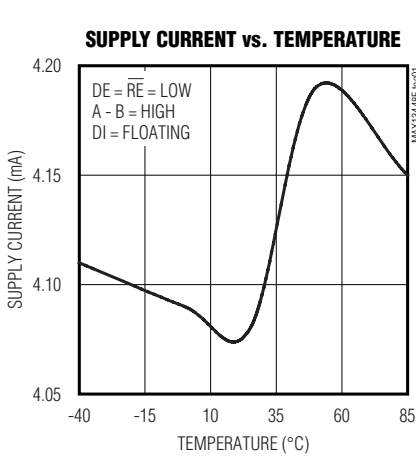

±80V Fault-Protected Full-Duplex RS-485 Transceiver

MAX13448E

Typical Operating Characteristics (continued)

($V_{CC} = +3.3V$, $T_A = +25^\circ C$, unless otherwise noted.)

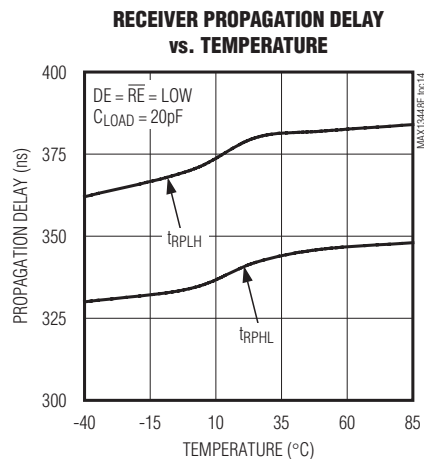
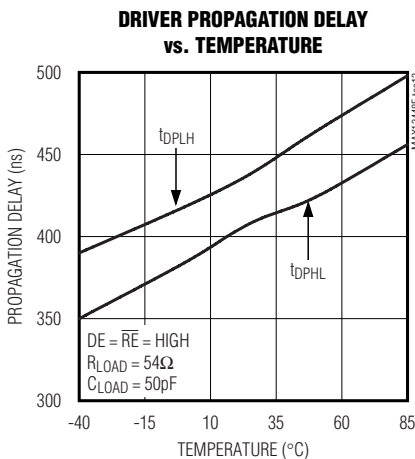
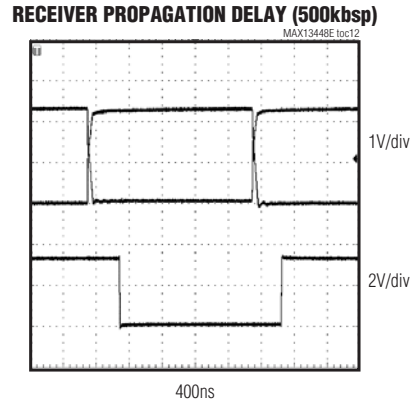
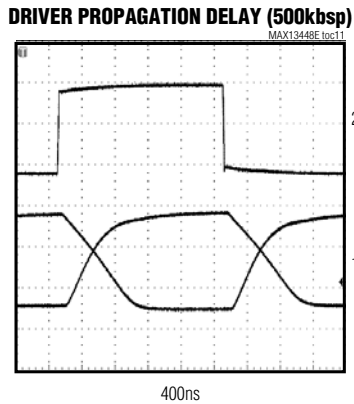
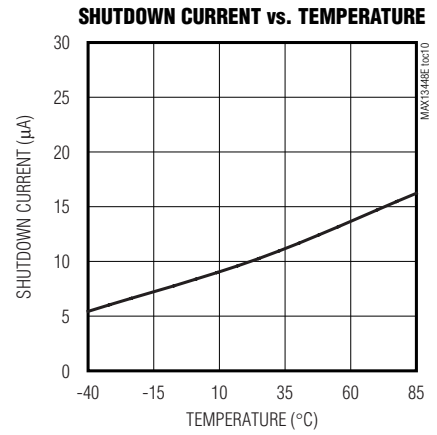
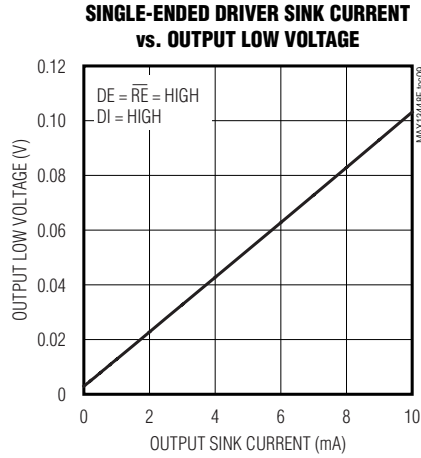
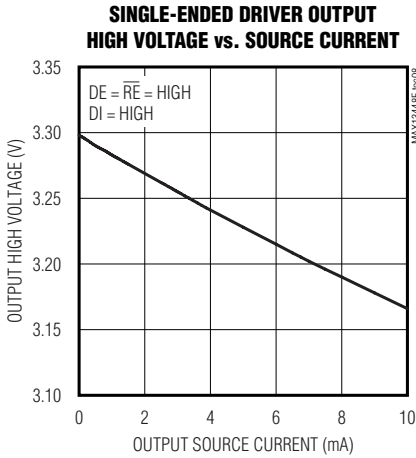

±80V Fault-Protected Full-Duplex RS-485 Transceiver

Pin Description

PIN	NAME	FUNCTION
1, 8, 13	N.C.	No Connection. Not internally connected. Connect N.C. to GND or leave it unconnected.
2	RO	Receiver Output. If receiver is enabled and $(A - B) \geq -50\text{mV}$, RO = high; if $(A - B) \geq -200\text{mV}$, RO = low.
3	$\overline{\text{RE}}$	Receiver Output Enable. Drive $\overline{\text{RE}}$ low to enable RO; RO is high impedance when $\overline{\text{RE}}$ is high. Drive $\overline{\text{RE}}$ high and DE low to enter low-power shutdown mode.
4	DE	Driver Output Enable. Drive DE high to enable the driver outputs. Drive DE low to put the outputs in high impedance. Drive $\overline{\text{RE}}$ high and DE low to enter low-power shutdown mode.
5	DI	Driver Input. Drive DI low to force the noninverting output low and the inverting output high. Drive DI high to force the noninverting output high and the inverting output low.
6, 7	GND	Ground
9	Y	Noninverting Driver Output
10	Z	Inverting Driver Output
11	B	Inverting Receiver Input
12	A	Noninverting Receiver Input
14	VCC	Positive Supply. $V_{CC} = +3.0\text{V}$ to $+5.5\text{V}$. Bypass V_{CC} to GND with a $1\mu\text{F}$ ceramic capacitor as close to V_{CC} as possible. Typical V_{CC} values are at $V_{CC} = +3.3\text{V}$ and $V_{CC} = +5.0\text{V}$.

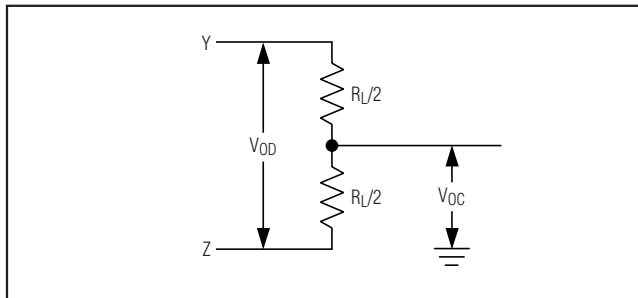

Figure 1. Driver DC Test Load

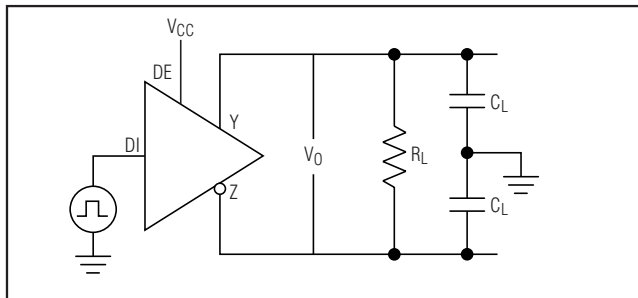

Figure 2. Driver Timing Test Circuit

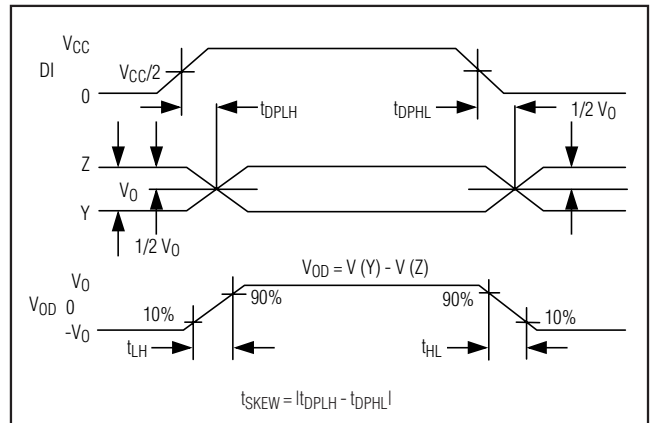

Figure 3. Driver Propagation Delays

±80V Fault-Protected Full-Duplex RS-485 Transceiver

MAX13448E

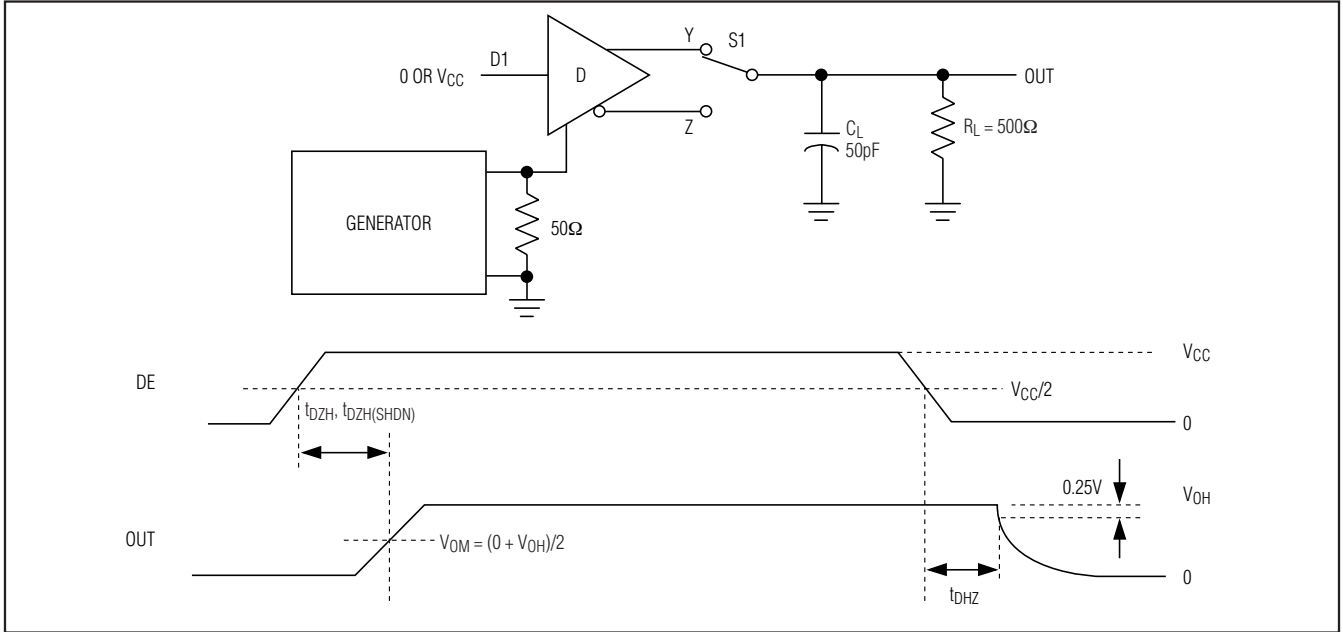

Figure 4. Driver Enable and Disable Times (t_{DZH} , $t_{DZH(SHDN)}$, t_{DZL})

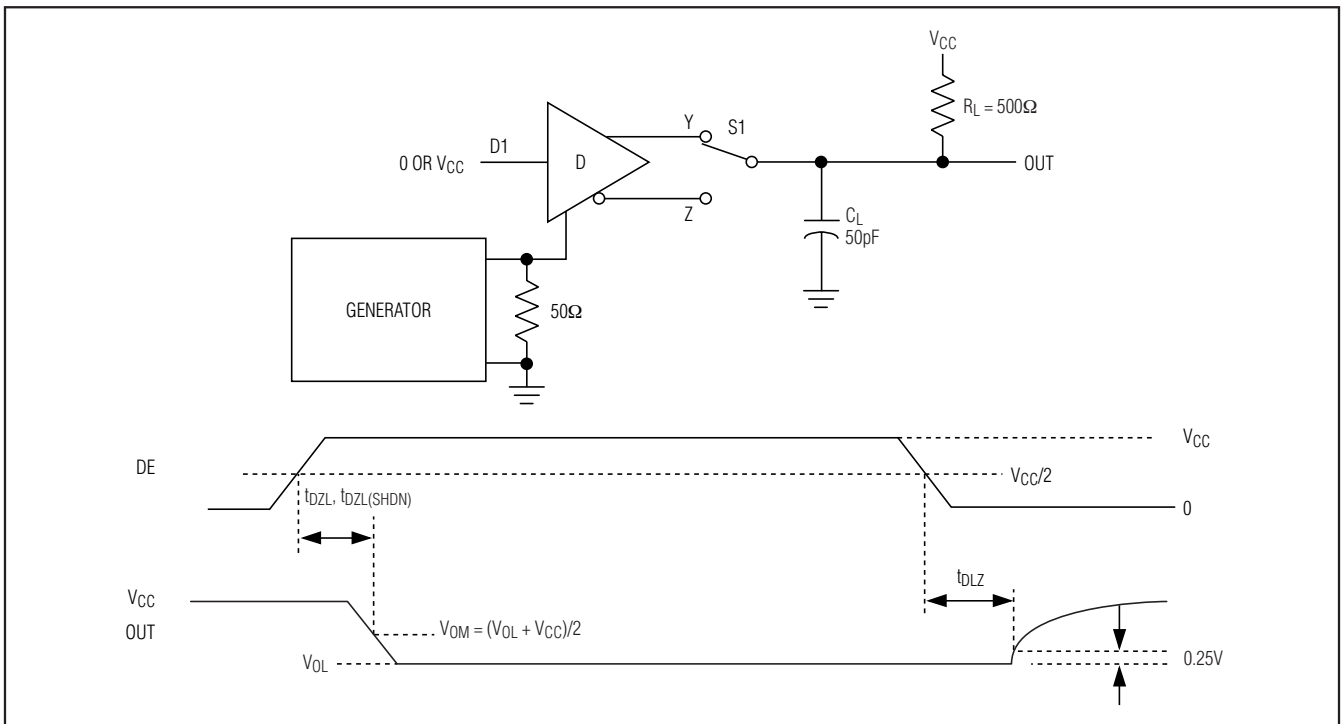

Figure 5. Driver Enable and Disable Times (t_{DLZ} , t_{DZL} , $t_{DZL(SHDN)}$)

±80V Fault-Protected Full-Duplex RS-485 Transceiver

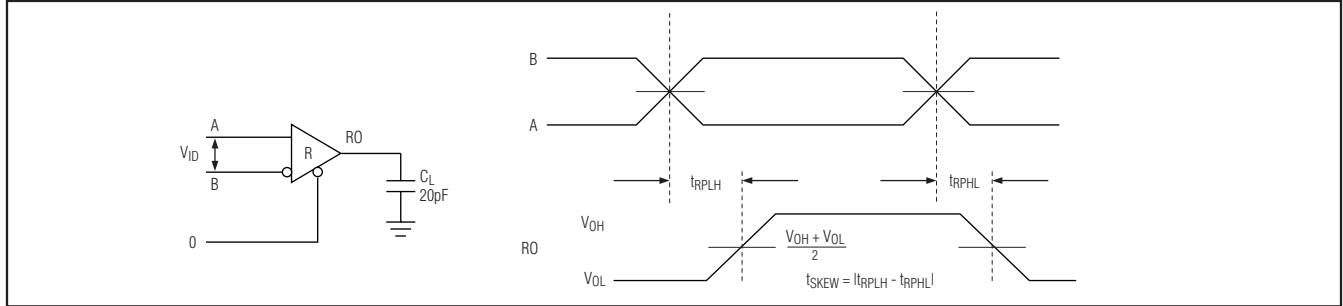

Figure 6. Receiver Propagation Delays

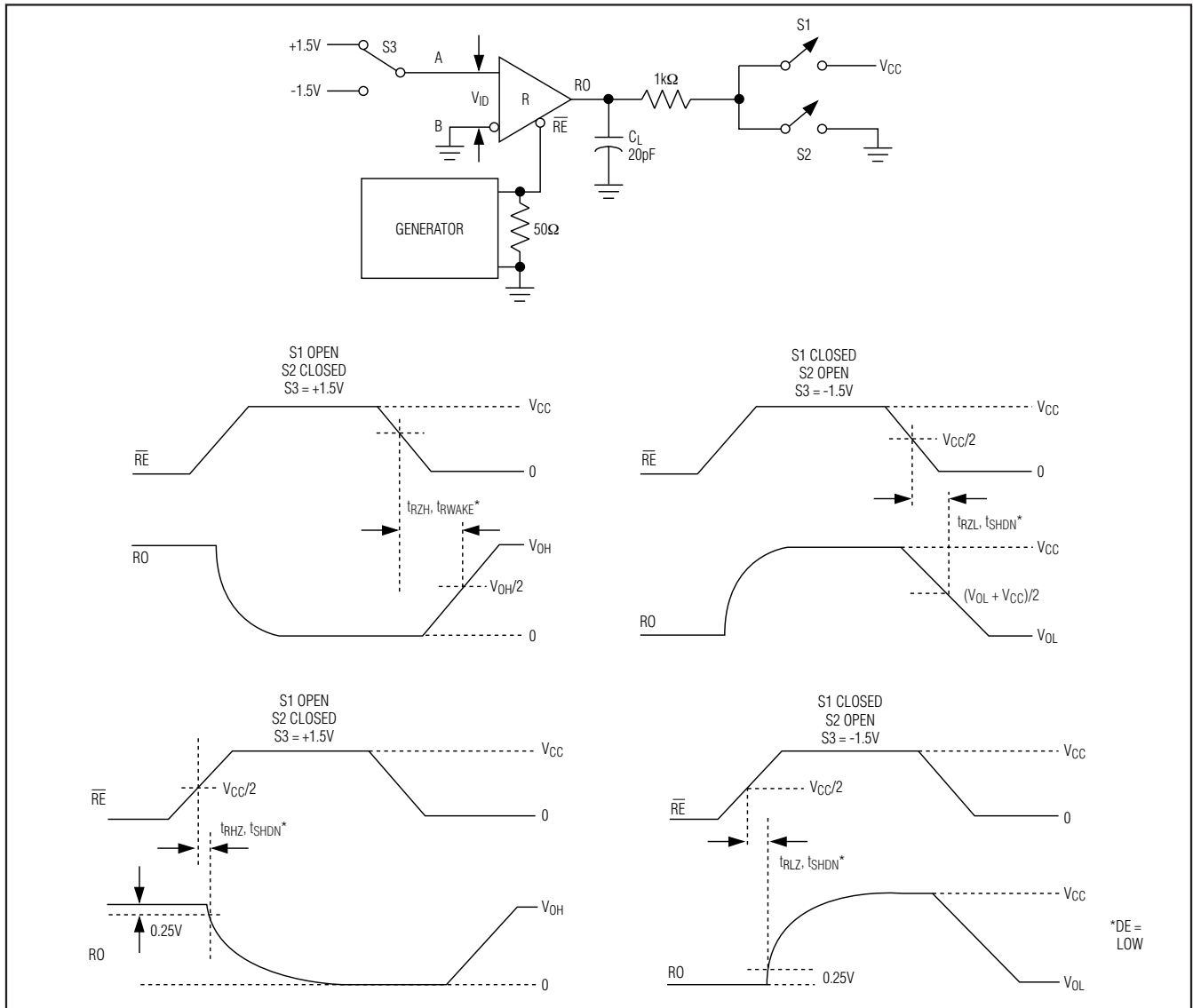

Figure 7. Receiver Enable and Disable Times

±80V Fault-Protected Full-Duplex RS-485 Transceiver

MAX13448E

Detailed Description

The MAX13448E ±80V fault-protected RS-485/RS-422 transceiver contains one driver and one receiver. This device features fail-safe circuitry, guaranteeing a logic-high receiver output when the receiver inputs are open or shorted, or when they are connected to a terminated transmission line with all drivers disabled. The device has a hot-swap input structure that prevents disturbances on the differential signal lines when a circuit board is plugged into a hot backplane. All receiver inputs and driver outputs are protected to ±8kV ESD using the Human Body Model. The MAX13448E features a reduced slew-rate driver that minimizes EMI and reduces reflections caused by improperly terminated cables, allowing error-free data transmission up to 500kbps.

Driver

The driver accepts a single-ended, logic-level input (DI) and converts it to a differential, RS-485/RS-422 level output (A and B). Deasserting the driver enable places the driver outputs (A and B) into a high-impedance state.

Receiver

The receiver accepts a differential, RS-485/RS-422 level input (A and B), and translates it to a single-ended, logic-level output (RO). Deasserting the receiver enable places the receiver outputs (RO) into a high-impedance state (see Table 1).

Low-Power Shutdown

Low-power shutdown is initiated by bringing DE low and RE high. In shutdown, the device draws a maximum of 100µA of supply current.

The device is guaranteed to not enter shutdown if DE is low and RE is high for 1µs. If the inputs are in this state for at least 1ms, the device is guaranteed to enter shutdown. In the shutdown state, the driver outputs (A and B) as well as the receiver output (RO) are in a high-impedance state.

±80V Fault Protection

In certain applications, such as industrial control, driver outputs and receiver inputs of an RS-485 device sometimes experience common-mode voltages in excess of the -7V to +12V range specified in the EIA/TIA-485 standard. In these applications, ordinary RS-485 devices (typical absolute maximum ratings of -8V to +12.5V) may experience damage without the addition of external protection devices.

Table 1. Function Table

TRANSMITTING				
INPUT			OUTPUT	
\overline{RE}	DE	DI	Z	Y
X	1	0	1	0
X	1	1	0	1
0	0	X	High Impedance	High Impedance
1	0	X	High Impedance (Shutdown)	
RECEIVING				
INPUT			OUTPUT	
\overline{RE}	DE	A - B	RO	
0	X	-50mV	1	
0	X	-200mV	0	
1	1	X	Disabled	
1	0	X	High Impedance (Shutdown)	

X = Don't care; shutdown mode, driver, and receiver outputs are high impedance.

To reduce system complexity and the need for external protection, the driver outputs and receiver inputs of the MAX13448E withstand voltage faults of up to ±80V with respect to ground without damage (see the *Absolute Maximum Ratings* section, Note 1). Protection is guaranteed regardless of whether the device is active, in shutdown, or without power. Certain parasitic effects present while driving an unterminated cable may cause the voltage seen at driver outputs to exceed the absolute maximum limit, while the DI input is switched during a ±80V fault on the A or B input. Therefore, a termination resistor is recommended in order to maximize the overvoltage fault protection while the DI input is being switched. If the DI input does not change state while the fault voltage is present, the MAX13448E will withstand up to the ±80V on the RS-485 inputs, regardless of the presence of a termination resistor. While the MAX13448E is not damaged by up to ±80V common-mode voltages, the RO, Y, and Z outputs will be in an indeterminate state if the common-mode voltage exceeds -7V to +12V.

True Fail-Safe

The MAX13448E guarantees a logic-high receiver output when the receiver inputs are shorted or open, or when they are connected to a terminated transmission line with all drivers disabled. This is done by setting the

±80V Fault-Protected Full-Duplex RS-485 Transceiver

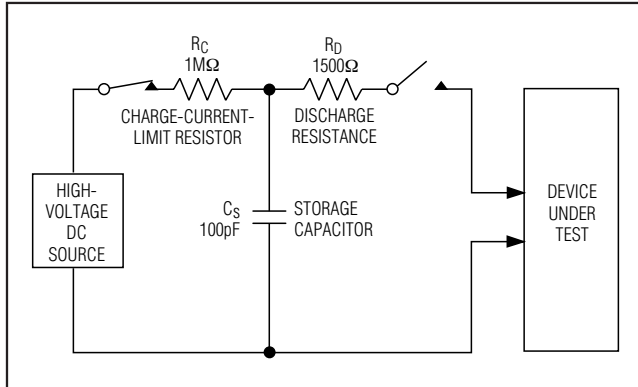

Figure 8a. Human Body ESD Test Model

receiver threshold between -50mV and -200mV. If the differential receiver input voltage (A - B) is greater than or equal to -50mV, RO is logic-high. If A - B is less than or equal to -200mV, RO is logic-low. In the case of a terminated bus with all transmitters disabled, the receiver's differential input voltage is pulled to 0V by the termination. With the receiver thresholds of the MAX13448E, this results in a logic-high with a 50mV minimum noise margin. The -50mV to -200mV threshold complies with the ±200mV EIA/TIA-485 standard.

±8kV ESD Protection

As with all Maxim devices, ESD-protection structures are incorporated on all pins to protect against electrostatic discharges encountered during handling and assembly. The driver outputs and receiver inputs of the MAX13448E have extra protection against static electricity. Maxim's engineers have developed state-of-the-art structures to protect these pins against ESD of ±8kV without damage. The ESD structures withstand high ESD in all states: normal operation, shutdown, and powered down. After an ESD event, the MAX13448E keeps working without latching or damage. ESD protection can be tested in various ways. The transmitter outputs and receiver inputs of the MAX13448E are characterized for protection to the following limits:

- ±8kV using the Human Body Model

ESD Test Conditions

ESD performance depends on a variety of conditions. Contact Maxim for a reliability report that documents test setup, test methodology, and test results.

Human Body Model

Figure 8a shows the Human Body Model, and Figure 8b shows the current waveform it generates when discharged into a low impedance. This model consists of a

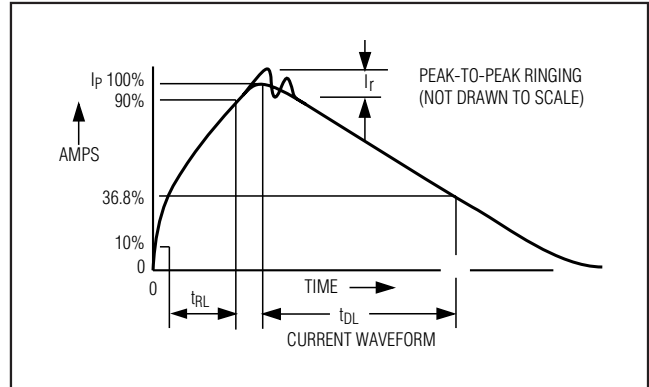

Figure 8b. Human Body Current Waveform

100pF capacitor charged to the ESD voltage of interest, which is then discharged into the test device through a 1.5kΩ resistor.

Driver Output Protection

Two mechanisms prevent excessive output current and power dissipation caused by faults or by bus contention. The first, a foldback current limit on the output stage, provides immediate protection against short circuits over the whole common-mode voltage range (see the *Typical Operating Characteristics*). The second, a thermal-shutdown circuit, forces the driver outputs into a high-impedance state if the die temperature exceeds +160°C (typ).

Hot-Swap Capability

Hot-Swap Inputs

When circuit boards are inserted into a powered backplane, disturbances to the data bus can lead to data errors. Upon initial circuit-board insertion, the data communication processor undergoes its own power-up sequence. During this period, the processor's logic-output drivers are high impedance and are unable to drive the DE input of the device to a defined logic level. Leakage currents up to ±10μA from the high-impedance state of the processor's logic drivers could cause standard CMOS enable inputs of a transceiver to drift to an incorrect logic level. Additionally, parasitic circuit-board capacitance could cause coupling of VCC or GND to the enable inputs. Without the hot-swap capability, these factors could improperly enable the transceiver's driver or receiver.

When VCC rises, an internal pulldown circuit holds DE low. After the initial power-up sequence, the pulldown circuit becomes transparent, resetting the hot-swap tolerable input.

±80V Fault-Protected Full-Duplex RS-485 Transceiver

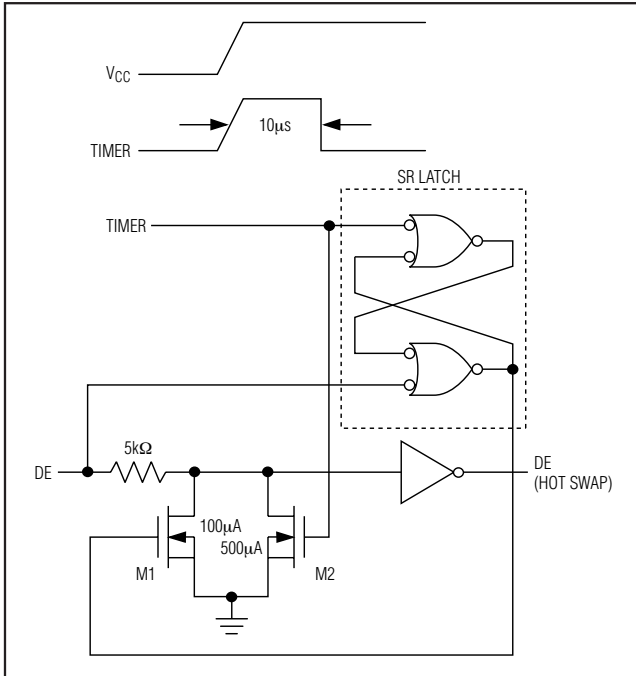

Figure 9. Simplified Structure of the Driver Enable Pin (DE)

Hot-Swap Input Circuitry

The enable inputs feature hot-swap capability. At the input there are two NMOS devices, M1 and M2 (Figure 9). When VCC ramps from zero, an internal 7µs timer turns on M2 and sets the SR latch that also turns on M1. Transistor M2, a 1.5mA current sink, and M1, a 100µA current sink, pull DE to GND through a 5kΩ resistor. M2 is designed to pull DE to the disabled state against an external parasitic capacitance up to 100pF that can drive DE high. After 7µs, the timer deactivates M2 while M1 remains on, holding DE low against three-state leakages that can drive DE high. M1 remains on until an external source overcomes the required input current. At this time, the SR latch resets and M1 turns off. When M1 turns off, DE reverts to a standard, high-impedance CMOS input.

Applications Information

256 Transceivers on the Bus

The RS-485 standard specifies the load each receiver places on the bus in terms of unit loads. An RS-485 compliant transmitter can drive 32 one-unit loads when used with a 120Ω cable that is terminated on both ends over a common-mode range of -7V to +12V. The

MAX13448E is specified as 1/8 unit loads. This means a compliant transmitter can drive up to 256 MAX13448E devices. Reducing the common mode and/or changing the characteristic impedance of the cable changes the maximum number of receivers that can be used. Refer to the TIA/EIA-485 specification for further details.

Proper Termination and Cabling/Wiring Configurations

When the data rates for RS-485 are high relative to its cable lengths, the system is subject to proper transmission line design. In most cases, a single, controlled-impedance cable or trace should be used and should be properly terminated on both ends with the characteristic impedance of the cable/trace. RS-485 transceivers should be connected to the cable/traces with minimum length wires to prevent stubs. Star configurations and improperly terminated cables can cause data loss. Refer to the *Applications* section of the Maxim website or to TIA/EIA publication TSB89 for further information.

Reduced EMI and Reflections

The MAX13448E features reduced slew-rate drivers that minimize EMI and reduce reflections caused by improperly terminated cables, allowing error-free data transmission up to 500kbps.

Line Length

The Telecommunications Industry Association (TIA) publishes the document TSB-89: *Application Guidelines for TIA/EIA-485-A* that is a good reference for determining maximum data rate vs. line length.

Typical Applications

The MAX13448E transceivers are designed for bidirectional data communications on multipoint bus transmission lines. Figure 10 shows a typical network application circuit. To minimize reflections, terminate the line at both ends in its characteristic impedance, and keep stub lengths off the main line as short as possible.

±80V Fault-Protected Full-Duplex RS-485 Transceiver

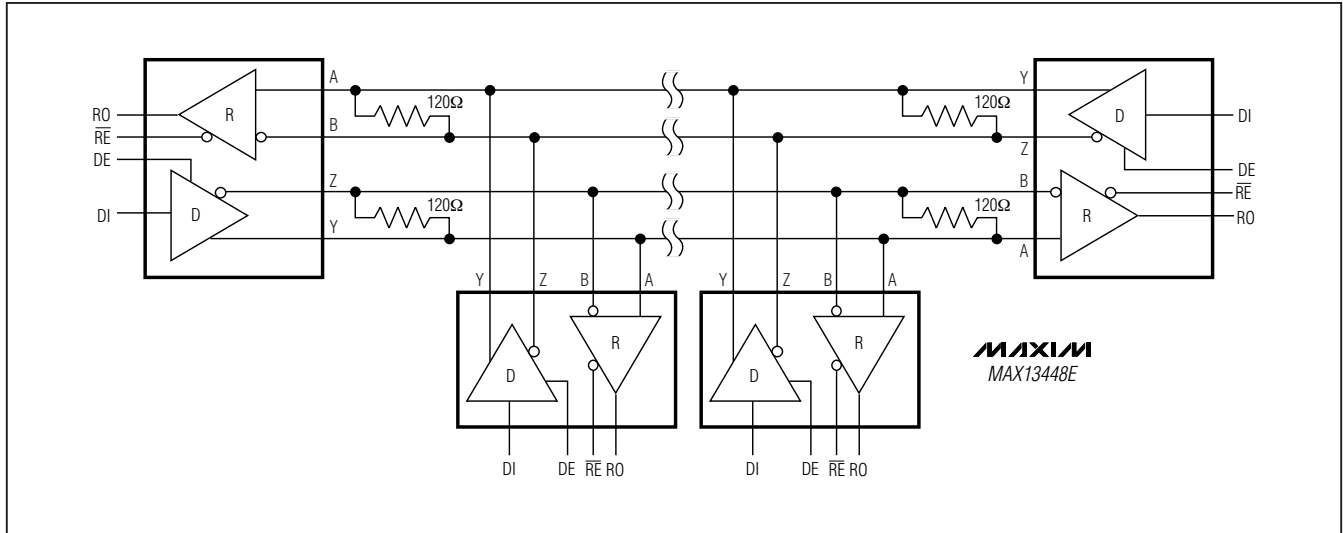
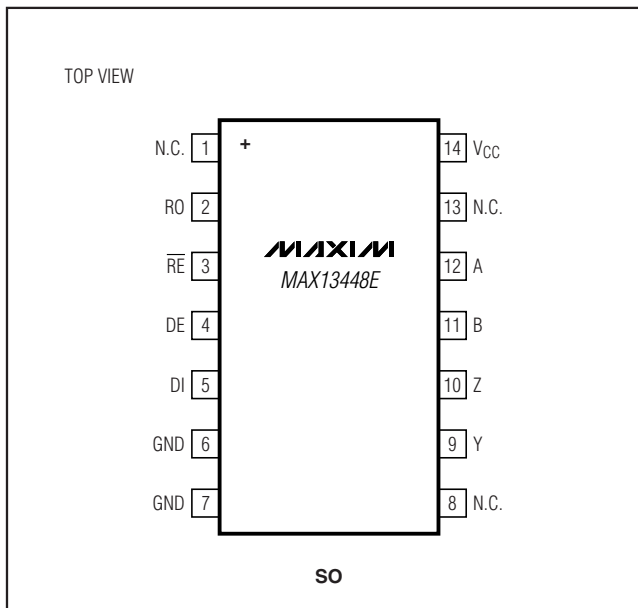

Figure 10. Typical Full-Duplex RS-485 Network

Pin Configuration



Chip Information

PROCESS: BiCMOS

Package Information

For the latest package outline information and land patterns, go to www.maxim-ic.com/packages.

PACKAGE TYPE	PACKAGE CODE	DOCUMENT NO.
14 SO	S14-5	21-0041

Maxim cannot assume responsibility for use of any circuitry other than circuitry entirely embodied in a Maxim product. No circuit patent licenses are implied. Maxim reserves the right to change the circuitry and specifications without notice at any time.

14 **Maxim Integrated Products, 120 San Gabriel Drive, Sunnyvale, CA 94086 408-737-7600**