



# ±80V Fault-Protected Can Transceiver with Autobaud

MAX13051

## General Description

The MAX13051 ±80V fault-protected CAN transceiver with autobaud is ideal for device net and other industrial network applications where overvoltage protection is required. The MAX13051 provides a link between the CAN protocol controller and the physical wires of the bus lines in a control area network (CAN).

The MAX13051 features three different modes of operation: high speed, slope control, and standby. High-speed mode allows data rates up to 1Mbps. The slope-control mode can be used to program the slew rate of the transmitter for data rates of up to 500kbps, reducing the effects of EMI and allowing the use of unshielded-twisted or parallel cable. In standby mode, the transmitter shuts off and a low-power receiver monitors the bus, waiting for a wake-up signal.

The MAX13051 provides a transmitter data (TXD) dominant timeout function that prevents erroneous CAN controllers from clamping the bus to a dominant level if the TXD input is held low for greater than 1ms. The MAX13051 also provides an autobaud feature allowing the microcontroller to compute the incoming baud rate without destroying CAN protocol communication. The MAX13051 input common-mode range is greater than ±12V, exceeding the ISO 11898 specification of -2V to +7V, and features ±6kV Human Body Model protection, making these devices ideal for harsh environments. The MAX13051 is available in an 8-pin SO package and is specified from the -40°C to +85°C and -40°C to +125°C temperature ranges.

## Applications

Industrial Networks  
Device Net Nodes  
Telecom  
HVAC

## Pin Configuration

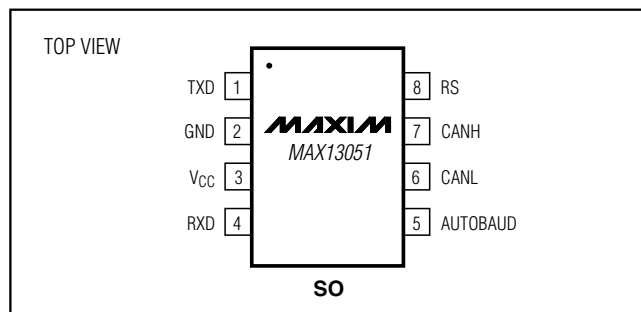

## Features

- ◆ Fully Compatible with the ISO 11898 Standard
- ◆ Autobaud Mode
- ◆ Short-Circuit Protection
- ◆ High-Speed Operation Up to 1Mbps
- ◆ Slope-Control Mode
- ◆ Low-Current Standby Mode
- ◆ Thermal Shutdown
- ◆ Transmit Data Dominant Timeout
- ◆ ±6kV Human Body Model ESD Protection
- ◆ Greater than ±12V Common-Mode Range

## Ordering Information

PART	TEMP RANGE	PIN-PACKAGE
MAX13051ESA	-40°C to +85°C	8 SO
MAX13051ASA	-40°C to +125°C	8 SO

## Typical Operating Circuit

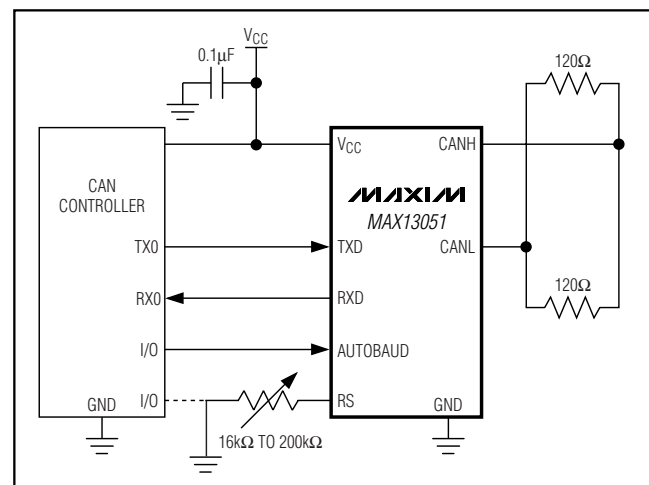

# ±80V Fault-Protected Can Transceiver with Autobaud

## ABSOLUTE MAXIMUM RATINGS

(All voltages referenced to GND.)

V <sub>CC</sub> .....	-0.3V to +6V
RS .....	-0.3V to (V <sub>CC</sub> + 0.3V)
TXD, RXD, AUTOBAUD .....	-0.3V to +6V
CANH, CANL .....	±80V
Continuous Power Dissipation (T <sub>A</sub> = +70°C) 8-Pin SO (derate 5.9mW/°C above +70°C) .....	470mW

Operating Temperature Range .....	-40°C to +125°C
Junction Temperature .....	+150°C
Storage Temperature Range .....	-65°C to +150°C
Lead Temperature (soldering, 10s) .....	+300°C

Stresses beyond those listed under "Absolute Maximum Ratings" may cause permanent damage to the device. These are stress ratings only, and functional operation of the device at these or any other conditions beyond those indicated in the operational sections of the specifications is not implied. Exposure to absolute maximum rating conditions for extended periods may affect device reliability.

## DC ELECTRICAL CHARACTERISTICS

(V<sub>CC</sub> = +5V ±5%, T<sub>A</sub> = T<sub>MIN</sub> to T<sub>MAX</sub>, unless otherwise noted. Typical values are at V<sub>CC</sub> = +5V, T<sub>A</sub> = +25°C.) (Note 1)

PARAMETER	SYMBOL	CONDITIONS	MIN	TYP	MAX	UNITS
Supply Current	I <sub>CC</sub>	Dominant, R <sub>L</sub> = 60Ω			72	mA
		Recessive			15	
Standby Current	I <sub>STANDBY</sub>				25	μA
Thermal-Shutdown Threshold	V <sub>TSH</sub>			+165		°C
Thermal-Shutdown Hysteresis				13		°C
<b>INPUT LEVELS (TXD, AUTOBAUD)</b>						
High-Level Input Voltage	V <sub>IH</sub>		2			V
Low-Level Input Voltage	V <sub>IL</sub>				0.8	V
High-Level Input Current	I <sub>IH</sub>	V <sub>TXD</sub> = V <sub>CC</sub>	-5		+5	μA
		V <sub>AUTOBAUD</sub> = V <sub>CC</sub>	+5		+15	
Low-Level Input Current	I <sub>IL</sub>	V <sub>TXD</sub> = GND	-300		-100	μA
		V <sub>AUTOBAUD</sub> = GND	-5		+5	
Input Capacitance	C <sub>IN</sub>			10		pF
<b>CANH, CANL TRANSMITTER</b>						
Recessive Bus Voltage	V <sub>CANH</sub> , V <sub>CANL</sub>	Normal mode, V <sub>TXD</sub> = V <sub>CC</sub> , no load	2		3	V
		Standby mode, no load	-100		+100	
Recessive Output Current	I <sub>CANH</sub> , I <sub>CANL</sub>	-76V < V <sub>CANH</sub> , V <sub>CANL</sub> < +76V		±3		mA
		-32V < V <sub>CANH</sub> , V <sub>CANL</sub> < +32V	-2.5		+2.5	
CANH Output Voltage	V <sub>CANH</sub>	V <sub>TXD</sub> = 0, dominant	3.0		4.5	V
CANL Output Voltage	V <sub>CANL</sub>	V <sub>TXD</sub> = 0, dominant	0.50		1.75	V
Matching Between CANH and CANL Output Voltage	ΔDOM	V <sub>TXD</sub> = 0, dominant, T <sub>A</sub> = +25°C (V <sub>CANH</sub> + V <sub>CANL</sub> ) - V <sub>CC</sub>	-100		+150	mV
Differential Output (V <sub>CANH</sub> - V <sub>CANL</sub> )	V <sub>DIFF</sub>	Dominant, V <sub>TXD</sub> = 0, 45Ω < R <sub>L</sub> < 60Ω	1.5		3.0	V
		Recessive, V <sub>TXD</sub> = V <sub>CC</sub> , no load	-50		+50	mV
CANH Short-Circuit Current	I <sub>CANHSC</sub>	V <sub>CANH</sub> = 0, V <sub>TXD</sub> = 0	-100	-70	-45	mA
CANL Short-Circuit Current	I <sub>CANLSC</sub>	V <sub>CANL</sub> = 5V, V <sub>TXD</sub> = 0	40	60	90	mA
		V <sub>CANL</sub> = 40V, V <sub>TXD</sub> = 0	40	60	90	
		V <sub>CANL</sub> = 76V, V <sub>TXD</sub> = 0		63		

# ±80V Fault-Protected Can Transceiver with Autobaud

**MAX13051**

## DC ELECTRICAL CHARACTERISTICS (continued)

(V<sub>CC</sub> = +5V ±5%, T<sub>A</sub> = T<sub>MIN</sub> to T<sub>MAX</sub>, unless otherwise noted. Typical values are at V<sub>CC</sub> = +5V, T<sub>A</sub> = +25°C.) (Note 1)

PARAMETER	SYMBOL	CONDITIONS	MIN	TYP	MAX	UNITS
<b>RXD OUTPUT LEVELS</b>						
RXD High Output Voltage Level	V <sub>OH</sub>	I = -100μA	0.8 × V <sub>CC</sub>		V <sub>CC</sub>	V
RXD Low Output Voltage Level	V <sub>OL</sub>	I = 5mA			0.4	V
<b>DC BUS RECEIVER</b> (V <sub>TXD</sub> = V <sub>CC</sub> , CANH and CANL externally driven)						
Differential Input Voltage	V <sub>DIFF</sub>	-12V < V <sub>CM</sub> < +12V	0.5	0.7	0.9	V
		-12V < V <sub>CM</sub> < +12V, standby mode	0.5		1.1	
Differential Input Hysteresis	V <sub>DIFF (HYST)</sub>	Normal mode, -12V < V <sub>CM</sub> < +12V		70		mV
Common-Mode Input Resistance	R <sub>ICM</sub>	Normal or standby mode, V <sub>CANH</sub> = V <sub>CANL</sub> = ±12V	15		35	kΩ
Matching Between CANH and CANL Common-Mode Input Resistance	R <sub>IC_MATCH</sub>		-3		+3	%
Differential Input Resistance	R <sub>DIFF</sub>	Normal or standby mode, V <sub>CANH</sub> - V <sub>CANL</sub> = 1V	25		75	kΩ
Common-Mode Input Capacitance		V <sub>TXD</sub> = V <sub>CC</sub>		20		pF
Differential Input Capacitance		V <sub>TXD</sub> = V <sub>CC</sub>		10		pF
Input Leakage Current	I <sub>LI</sub>	V <sub>CC</sub> = 0, V <sub>CANH</sub> = V <sub>CANL</sub> = 5V	-5		+5	μA
<b>SLOPE CONTROL (RS )</b>						
Input Voltage for High-Speed Mode	V <sub>IL_RS</sub>				0.3 × V <sub>CC</sub>	V
Input Voltage for Standby	V <sub>IH_RS</sub>		0.75 × V <sub>CC</sub>			V
Slope-Control Mode Voltage	V <sub>SLOPE</sub>	-200μA < I <sub>RS</sub> < 10μA	0.4 × V <sub>CC</sub>		0.6 × V <sub>CC</sub>	V
High-Speed Mode Current	I <sub>IL_RS</sub>	V <sub>RS</sub> = 0	-500			μA

## TIMING CHARACTERISTICS

(V<sub>CC</sub> = +5V ±5%, R<sub>L</sub> = 60Ω, C<sub>L</sub> = 100pF, T<sub>A</sub> = T<sub>MIN</sub> to T<sub>MAX</sub>, unless otherwise noted. Typical values are at V<sub>CC</sub> = +5V and T<sub>A</sub> = +25°C.)

PARAMETER	SYMBOL	CONDITIONS	MIN	TYP	MAX	UNITS
Delay TXD to Bus Active	t <sub>ONTXD</sub>	V <sub>RS</sub> = 0 (Figure 1)		66	110	ns
Delay TXD to Bus Inactive	t <sub>OFFTXD</sub>	V <sub>RS</sub> = 0 (Figure 1)		61	95	ns
Delay Bus to Receiver Active	t <sub>ONRXD</sub>	V <sub>RS</sub> = 0 (Figure 1)		54	115	ns
Delay Bus to Receiver Inactive	t <sub>OFFRXD</sub>	V <sub>RS</sub> = 0 (Figure 1)		46	160	ns
Delay TXD to RXD Active	t <sub>ONLOOP</sub>	V <sub>RS</sub> = 0 (Figure 1)		121	255	ns
Delay TXD to RXD Inactive	t <sub>OFFLOOP</sub>	V <sub>RS</sub> = 0 (Figure 1)		108	255	ns
Delay TXD to RXD Active (Dominant Loop Delay) Slew-Rate Controlled	t <sub>ONLOOP_S</sub>	R <sub>RS</sub> = 24kΩ (500kbps)		280	450	μs
		R <sub>RS</sub> = 100kΩ (125kbps)		0.82	1.6	
		R <sub>RS</sub> = 180kΩ (62.5kbps)		1.37	5	
Delay TXD to RXD Inactive (Loop Delay) Slew-Rate Controlled	t <sub>OFFLOOP_S</sub>	R <sub>RS</sub> = 24kΩ (500kbps)		386	600	μs
		R <sub>RS</sub> = 100kΩ (125kbps)		0.74	1.6	
		R <sub>RS</sub> = 180kΩ (62.5kbps)		0.97	5	

# ±80V Fault-Protected Can Transceiver with Autobaud

## TIMING CHARACTERISTICS (continued)

(V<sub>CC</sub> = +5V ±5%, R<sub>L</sub> = 60Ω, C<sub>L</sub> = 100pF, T<sub>A</sub> = T<sub>MIN</sub> to T<sub>MAX</sub>, unless otherwise noted. Typical values are at V<sub>CC</sub> = +5V and T<sub>A</sub> = +25°C.)

PARAMETER	SYMBOL	CONDITIONS	MIN	TYP	MAX	UNITS
Differential-Output Slew Rate	SR	R <sub>RS</sub> = 24kΩ (500kbps)		10		V/μs
		R <sub>RS</sub> = 100kΩ (125kbps)		2.7		
		R <sub>RS</sub> = 180kΩ (62.5kbps)		1.6		
Dominant Time for Wake-Up Through Bus (Figure 2)	t <sub>WAKE</sub>	Standby mode, V <sub>DIFF</sub> = 3V	0.75	1.5	3.00	μs
TXD Dominant Timeout	t <sub>DOM</sub>	V <sub>TXD</sub> = 0	0.3	0.6	1.0	ms
ESD Protection		Human Body Model (CANH, CANL)		6		kV

**Note 1:** All currents into device are positive and all currents out of the device are negative. All voltages are referenced to device ground unless otherwise noted.

## Timing Diagrams

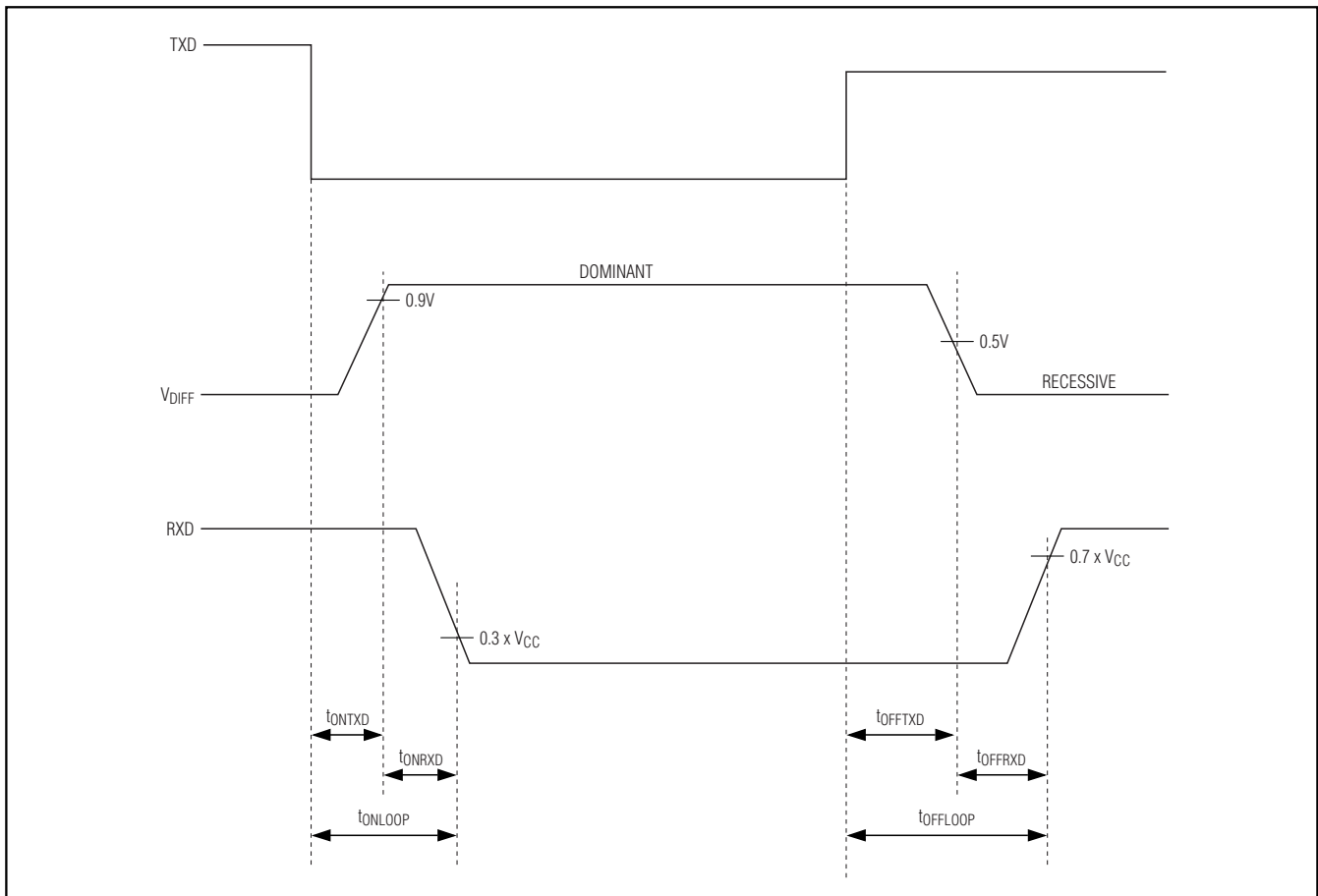

Figure 1. Timing Diagram

# ±80V Fault-Protected Can Transceiver with Autobaud

MAX13051

## Timing Diagrams (continued)

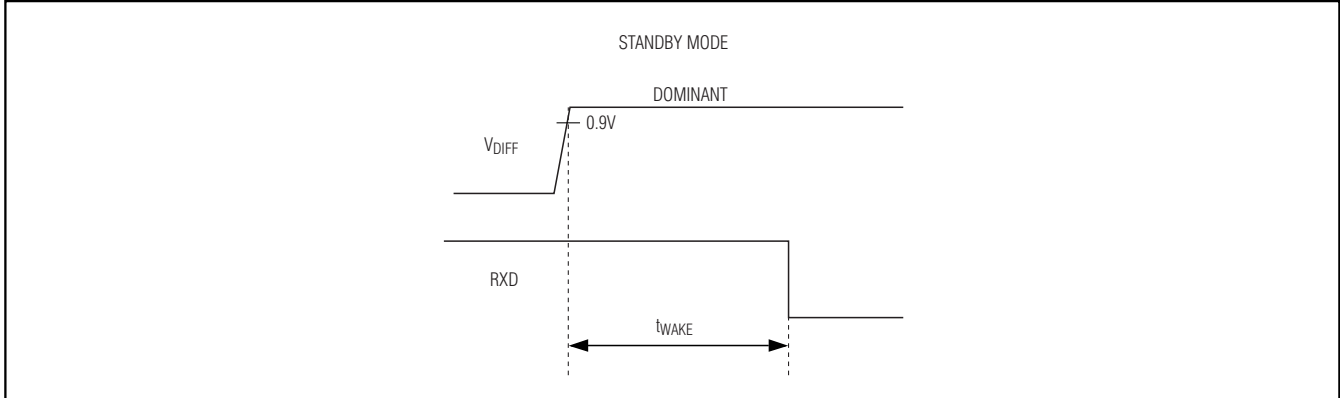
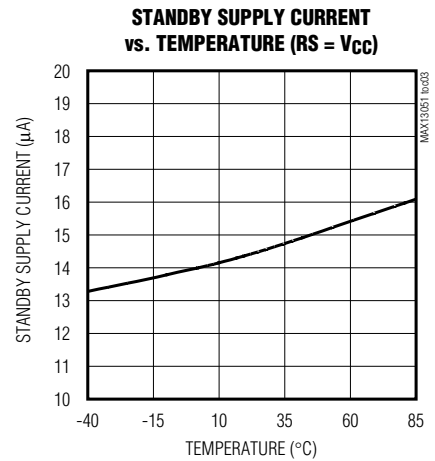
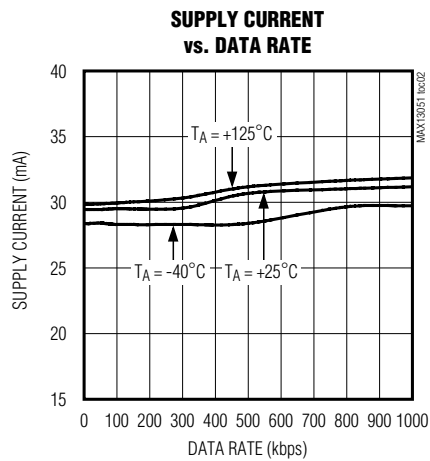
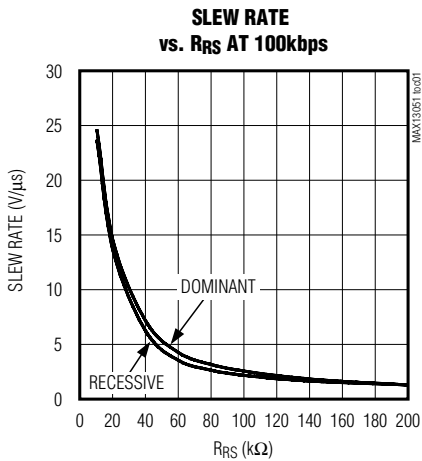

Figure 2. Timing Diagram for Standby and Wake-Up Signal

## Typical Operating Characteristics

( $V_{CC} = +5V$ ,  $R_L = 60\Omega$ ,  $C_L = 100pF$ ,  $T_A = +25^\circ C$ , unless otherwise specified.)



# ±80V Fault-Protected Can Transceiver with Autobaud

## Typical Operating Characteristics (continued)

(V<sub>CC</sub> = +5V, R<sub>L</sub> = 60Ω, C<sub>L</sub> = 100pF, T<sub>A</sub> = +25°C, unless otherwise specified.)

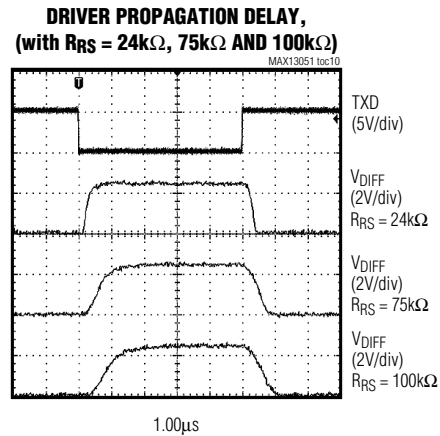
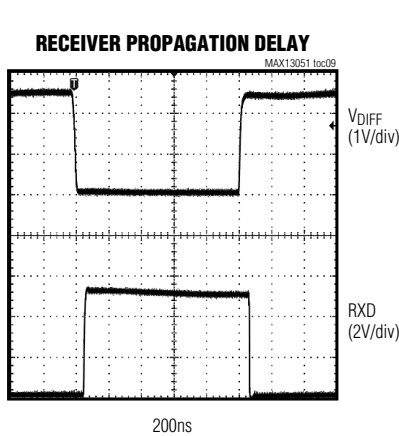
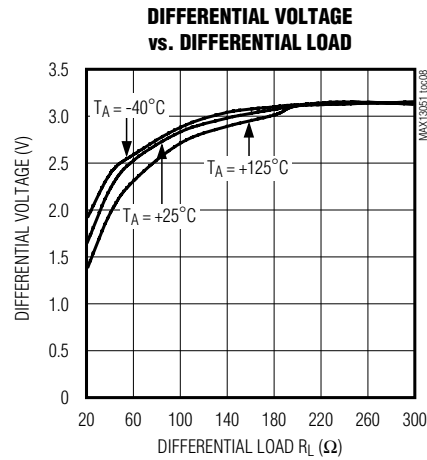
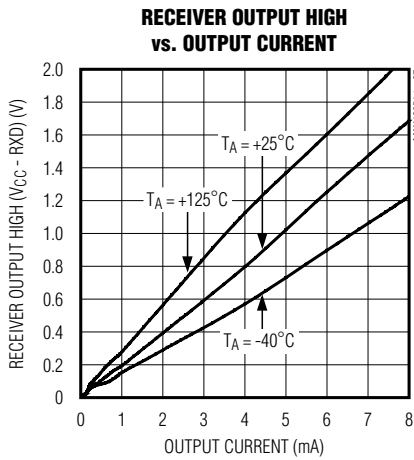
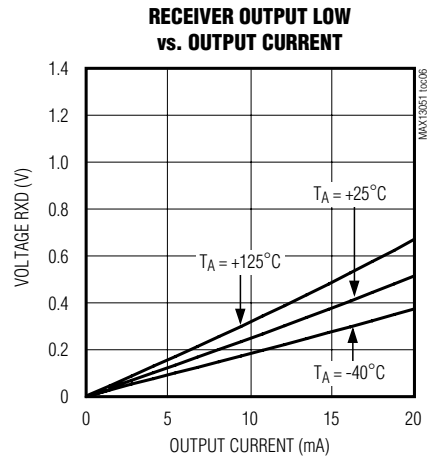
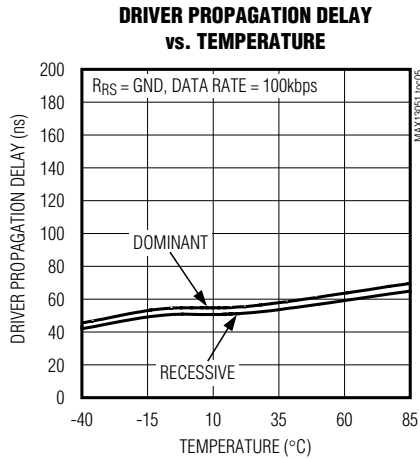
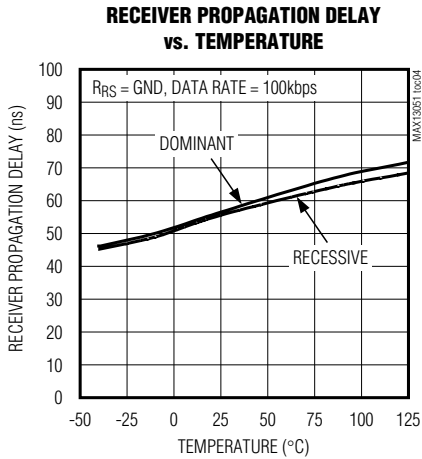

# ±80V Fault-Protected Can Transceiver with Autobaud

MAX13051

## Typical Operating Characteristics (continued)

( $V_{CC} = +5V$ ,  $R_L = 60\Omega$ ,  $C_L = 100pF$ ,  $T_A = +25^\circ C$ , unless otherwise specified.)

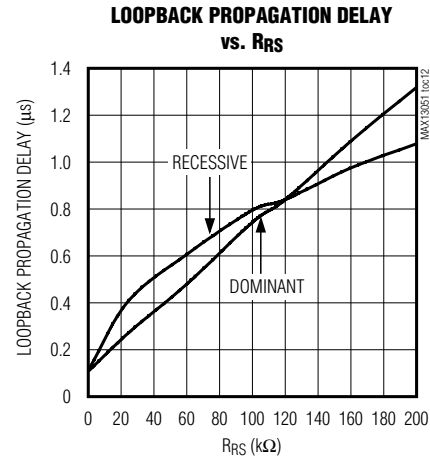
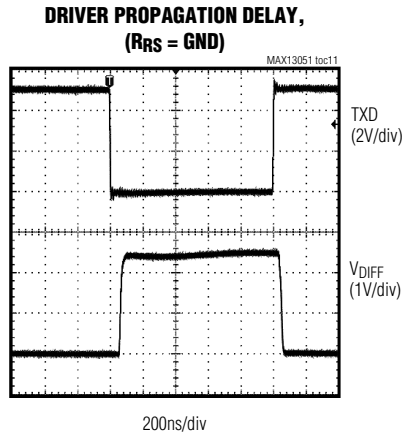

## Pin Description

PIN	NAME	FUNCTION
1	TXD	Transmit Data Input. TXD is a CMOS/TTL-compatible input from a CAN controller.
2	GND	Ground
3	$V_{CC}$	Supply Voltage. Bypass $V_{CC}$ to GND with a 0.1 $\mu F$ capacitor.
4	RXD	Receive Data Output. RXD is a CMOS/TTL-compatible output from the physical bus lines CANH and CANL.
5	AUTOBAUD	Autobaud Input. Drive AUTOBAUD low for normal operation. Drive AUTOBAUD high for autobaud operation. When operating in autobaud mode, TXD is looped back to RXD without applying a differential signal at CANH and CANL.
6	CANL	CAN Bus Line Low
7	CANH	CAN Bus Line High
8	RS	Mode-Select Input. Drive RS low or connect to GND for high-speed operation. Connect a resistor between RS and GND to control output slope. Drive RS high to put into standby mode.

# ±80V Fault-Protected Can Transceiver with Autobaud

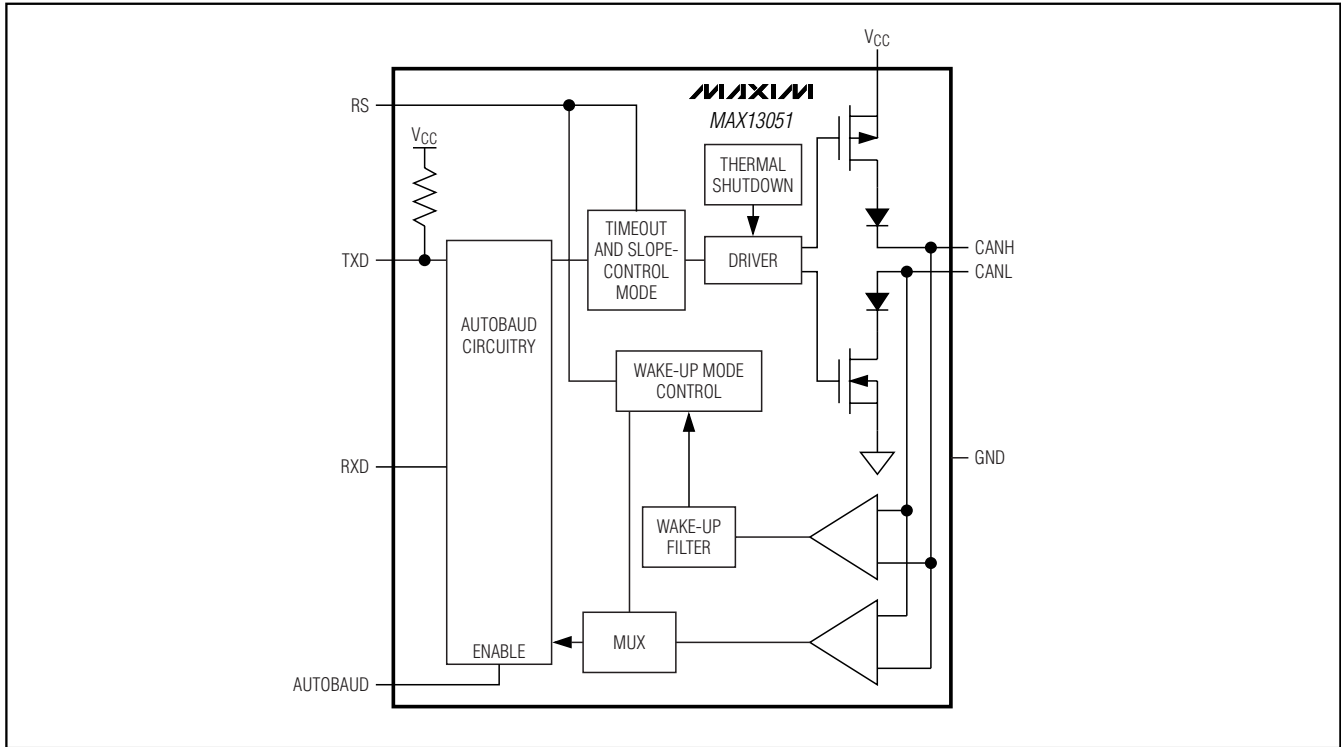

Figure 3. MAX13051 Functional Diagram

## Detail Description

### ±80V Fault Tolerant

The MAX13051 features ±80V fault protection. This extended voltage range of CANH and CANL allows communication in high-voltage systems up to 80V.

### Operating Modes

#### High-Speed Mode

The MAX13051 can achieve transmission rates of up to 1Mbps when operating in high-speed mode. To operate in high-speed mode, short RS to ground.

#### Slope-Control Mode

Connect a resistor from RS to ground to select slope-control mode (Table 1). In slope-control mode, CANH and CANL slew rates are controlled by the resistor, ( $16\text{k}\Omega \leq R_{RS} \leq 200\text{k}\Omega$ ), connected between RS and GND. Controlling the rise and fall slopes reduces high-frequency EMI and allows the use of an unshielded-twisted pair or a parallel pair of wires as bus lines. The slew rate can be approximated using the formula below:

$$SR (V/\mu s) \approx \frac{250}{R_{RS}}$$

where, SR is the desired slew rate and  $R_{RS}$  is in  $\text{k}\Omega$ .

#### Standby Mode

In standby mode (RS = high), the transmitter is switched off and the receiver is switched to a low-current/low-speed state. The supply current reduces to 15 $\mu\text{A}$  to detect and recognize a wake-up event on the bus line. During standby mode, the bus line is monitored with a low-differential comparator. Once the comparator detects a dominant bus level greater than TWAKE, RXD pulls low.

#### Autobaud Mode

The MAX13051 logic-controlled autobaud input allows a microcontroller to compute the incoming baud rate without destroying CAN protocol communication. When operating in autobaud mode, TXD is looped back to RXD without applying a differential signal at CANH and CANL. See Figure 4.



# ±80V Fault-Protected Can Transceiver with Autobaud

**Table 1. Mode Selection Truth Table**

CONDITION FORCED AT PIN RS	MODE	RESULTING CURRENT AT RS
$V_{RS} \leq 0.3V \times V_{CC}$	High Speed	$200\mu A \leq  I_{RS}  \leq 500\mu A$
$0.4V \times V_{CC} < V_{RS} \leq 0.6V \times V_{CC}$	Slope Control	$10\mu A \leq  I_{RS}  \leq 200\mu A$
$V_{RS} \geq 0.75V \times V_{CC}$	Standby	$ I_{RS}  \leq 10\mu A$

**Table 2. Transmitter and Receiver Truth Table when Not Connected to the Bus**

TXD	RS	CANH	CANL	BUS STATE	RXD
Low	$V_{RS} \leq 0.75V \times V_{CC}$	High	Low	Dominant	Low
High or Float	$V_{RS} \leq 0.75V \times V_{CC}$	$V_{CC} / 2$	$V_{CC} / 2$	Recessive	High
X	$V_{RS} \geq 0.75V \times V_{CC}$	R <sub>ICM</sub> GND	R <sub>ICM</sub> GND	Recessive	High

\*Common-mode input resistance.

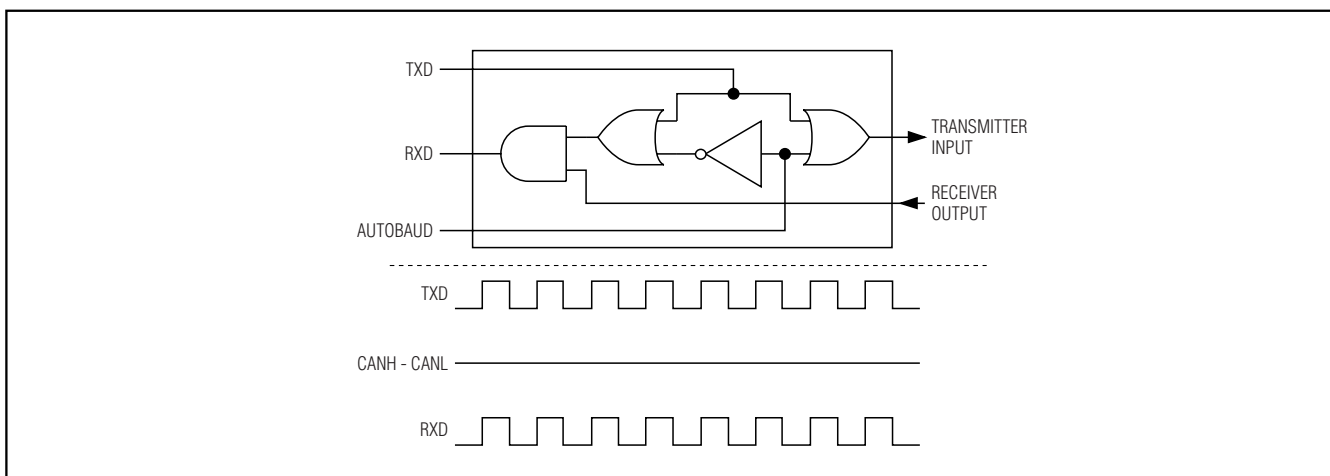

Figure 4. MAX13051 Autobaud Timing Diagram

### Transmitter

The transmitter converts a single-ended input (TXD) from the CAN controller to differential outputs for the bus lines (CANH, CANL). The truth table for the transmitter and receiver is given in Table 2.

### TXD Dominant Timeout

The MAX13051 provides a transmitter-dominant timeout that prevents erroneous CAN controllers from clamping the bus to a dominant level by maintaining a continuous low TXD signal. When the TXD remains in the dominant state for greater than 1ms (max), the transmitter becomes disabled, driving the bus line to a recessive state (Figure 5). After a dominant timeout fault, the

MAX13051's transmitter becomes enabled upon detecting a rising edge at TXD.

### Receiver

The receiver reads differential inputs from the bus lines (CANH, CANL) and transfers this data as a single-ended output (RXD) to the CAN controller. It consists of a comparator that senses the difference,  $V_{DIFF} = (CANH - CANL)$ , with respect to an internal threshold of 0.7V. If this difference is positive, ( $V_{DIFF} > 0.9V$ ), a logic-low is present at RXD. If negative, ( $V_{DIFF} < 0.5V$ ), a logic-high is present. The receiver always echoes the CAN bus data when not operating in autobaud mode.

# ±80V Fault-Protected Can Transceiver with Autobaud

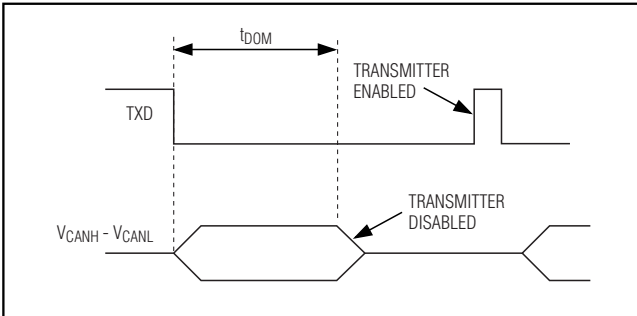

Figure 5. Transmitter-Dominant Timeout Timing Diagram

The CANH and CANL common-mode range is ±12V exceeding the ISO 11898 specification at -2V to +7V. RXD is logic-high when CANH and CANL are shorted or undriven.

### Driver Output Protection

The MAX13051 current-limiting feature protects the transmitter output stage against a short circuit to a positive and negative battery voltage. Although the power dissipation increases during this fault condition, current-limit protection prevents destruction of the transmitter output stage. Upon removal of a short, the MAX13051 resumes normal operation.

### Thermal Shutdown

If the junction temperature exceeds +165°C, the device is switched off. The hysteresis is approximately 13°C, disabling thermal shutdown once the temperature drops below 152°C. In thermal shutdown, CANH and CANL go recessive. After a thermal-shutdown event, the MAX13051 resumes normal operation when the

junction temperature drops below the thermal-shut-down hysteresis, and upon the MAX13051 detecting a rising edge at TXD.

## Applications Information

### Reduced EMI and Reflections

In slope-control mode, the CANH and CANL outputs are slew-rate limited, minimizing high-frequency EMI, and reducing reflections caused by improperly terminated cables.

In multidrop CAN applications, it is important to maintain a direct point-to-point wiring scheme. A single pair of wires should connect each element of the CAN bus, and the two ends of the bus should be terminated with 120Ω resistors, see Figure 6. A star configuration should never be used.

Any deviation from the point-to-point wiring scheme creates a stub. The high-speed edge of the CAN data on a stub can create reflections back down the bus. These reflections can cause data errors by eroding the noise margin of the system.

Although stubs are unavoidable in a multidrop system, care should be taken to keep these stubs as small as possible, especially in high-speed mode. In slope-control mode, the requirements are not as rigorous, but stub length should still be minimized.

### Layout Consideration

CANH and CANL are differential signals and steps should be taken to insure equivalent parasitic capacitance. Place the resistor at RS as close as possible to the MAX13051 to minimize any possible noise coupling at the input.

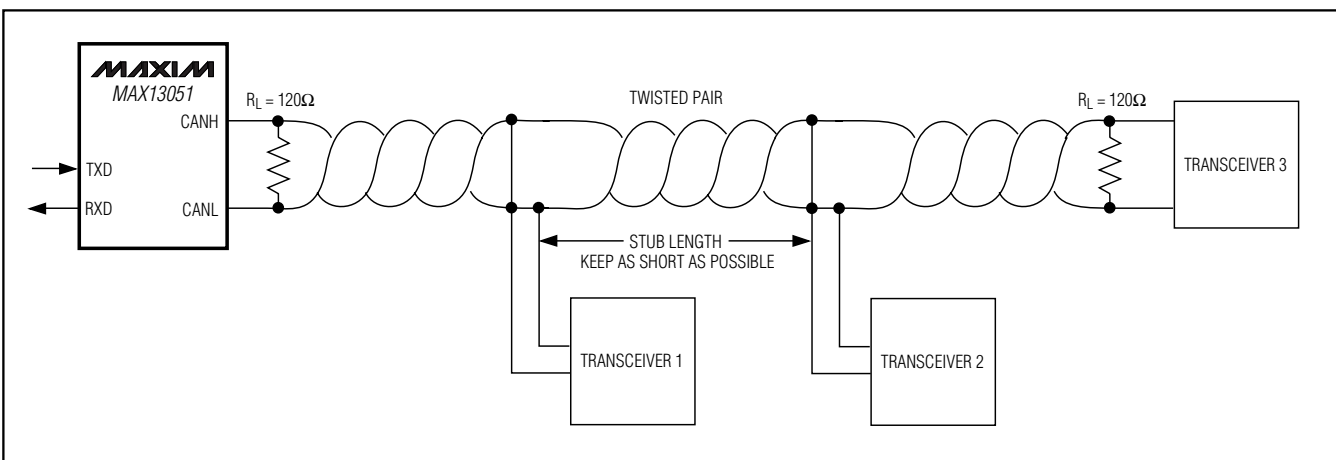

Figure 6. Multiple Receivers Connected to CAN Bus

# ±80V Fault-Protected Can Transceiver with Autobaud

MAX13051

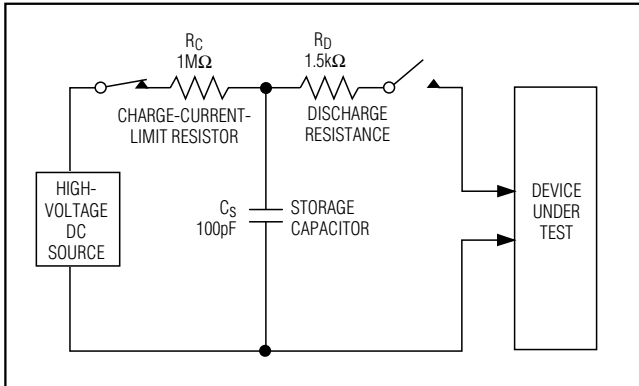

Figure 7. Human Body ESD Test Model

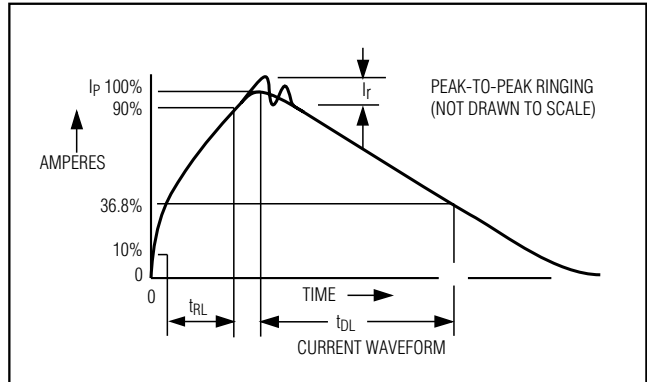

Figure 8. Human Body Model Current Waveform

## Power Supply and Bypassing

The MAX13051 requires no special layout considerations beyond common practices. Bypass  $V_{CC}$  to GND with a 0.1 $\mu$ F ceramic capacitor mounted closely to the IC with short lead lengths and wide trace widths.

## ±6kV ESD Protection

ESD protection structures are incorporated on all inputs to protect against ESD encountered during handling and assembly. CANH and CANL inputs have extra protection to protect against static electricity found in normal operation. Maxim's engineers have developed state-of-the-art structures to protect these pins (CANH, CANL) against ±6kV ESD without damage. ESD protection can be tested in several ways. The CANH and CANL inputs are characterized for protection to ±6kV using the Human Body Model.

## ESD Test Conditions

ESD performance depends on a number of conditions. Contact Maxim for a reliability report that documents test setup, methodology, and results.

## Human Body Model

Figure 7 shows the Human Body Model, and Figure 8 shows the current waveform it generates when discharged into a low impedance. This model consists of a 100pF capacitor charged to the ESD voltage of interest, which is then discharged into the device through a 1.5k $\Omega$  resistor.

## Chip Information

TRANSISTOR COUNT: 1400

PROCESS: BiCMOS

# ±80V Fault-Protected Can Transceiver with Autobaud

## Package Information

(The package drawing(s) in this data sheet may not reflect the most current specifications. For the latest package outline information, go to [www.maxim-ic.com/packages](http://www.maxim-ic.com/packages).)

SOICN .150

**TOP VIEW**

**FRONT VIEW**

**SIDE VIEW**

DIM	INCHES		MILLIMETERS	
	MIN	MAX	MIN	MAX
A	0.053	0.069	1.35	1.75
A1	0.004	0.010	0.10	0.25
B	0.014	0.019	0.35	0.49
C	0.007	0.010	0.19	0.25
e	0.050 BSC		1.27 BSC	
E	0.150	0.157	3.80	4.00
H	0.228	0.244	5.80	6.20
L	0.016	0.050	0.40	1.27

VARIATIONS:

DIM	INCHES		MILLIMETERS		N	MS012
	MIN	MAX	MIN	MAX		
D	0.189	0.197	4.80	5.00	8	AA
D	0.337	0.344	8.55	8.75	14	AB
D	0.386	0.394	9.80	10.00	16	AC

**NOTES:**

1. D&E DO NOT INCLUDE MOLD FLASH.
2. MOLD FLASH OR PROTRUSIONS NOT TO EXCEED 0.15mm (.006").
3. LEADS TO BE COPLANAR WITHIN 0.10mm (.004").
4. CONTROLLING DIMENSION: MILLIMETERS.
5. MEETS JEDEC MS012.
6. N = NUMBER OF PINS.

<b>DALLAS SEMICONDUCTOR</b>		<b>MAXIM</b>	
<small>PROPRIETARY INFORMATION</small>			
TITLE: <b>PACKAGE OUTLINE, .150" SOIC</b>			
<small>APPROVAL</small>	<small>DOCUMENT CONTROL NO.</small> <b>21-0041</b>	<small>REV.</small> <b>B</b>	<small>1/1</small>

Maxim cannot assume responsibility for use of any circuitry other than circuitry entirely embodied in a Maxim product. No circuit patent licenses are implied. Maxim reserves the right to change the circuitry and specifications without notice at any time.

12 **Maxim Integrated Products, 120 San Gabriel Drive, Sunnyvale, CA 94086 408-737-7600**