

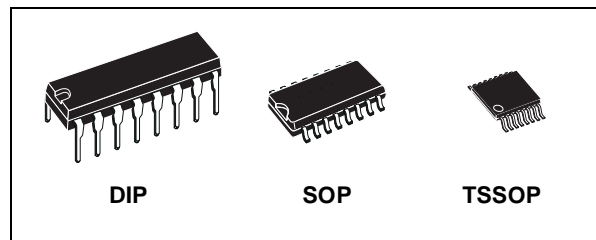

# M74HC4094

## 8 BIT SIPO SHIFT LATCH REGISTER (3-STATE)

- HIGH SPEED :  
 $f_{MAX} = 80 \text{ MHz (TYP.) at } V_{CC} = 6V$
- LOW POWER DISSIPATION:  
 $I_{CC} = 4\mu\text{A (MAX.) at } T_A = 25^\circ\text{C}$
- HIGH NOISE IMMUNITY:  
 $V_{NIH} = V_{NIL} = 28 \% V_{CC} \text{ (MIN.)}$
- SYMMETRICAL OUTPUT IMPEDANCE:  
 $|I_{OH}| = I_{OL} = 4\text{mA (MIN)}$
- BALANCED PROPAGATION DELAYS:  
 $t_{PLH} \cong t_{PHL}$
- WIDE OPERATING VOLTAGE RANGE:  
 $V_{CC} \text{ (OPR)} = 2V \text{ to } 6V$
- PIN AND FUNCTION COMPATIBLE WITH  
 74 SERIES 4094



### ORDER CODES

PACKAGE	TUBE	T & R
DIP	M74HC4094B1R	
SOP	M74HC4094M1R	M74HC4094RM13TR
TSSOP		M74HC4094TTR

### DESCRIPTION

The M74HC4094 is an high speed CMOS 8 BIT SIPO SHIFT LATCH REGISTER fabricated with silicon gate C<sup>2</sup>MOS technology. This device consists of an 8 bit shift register and an 8 bit latch with 3 state output buffer. Data is shifted serially through the shift register on the positive going transition of the clock input signal. The output of the last stage (Qs) can be used to cascade several devices. Data on the Qs output is transferred to a second output (Qs') on the following negative transition of

the clock input signal. The data of each stage of the shift register is provided with a latch, which latches data on the negative going transition of the STROBE input signal. When the STROBE input is held high, data propagates through the latch to a 3-state output buffer. This buffer is enabled when OUTPUT ENABLE input is taken high. All inputs are equipped with protection circuits against static discharge and transient excess voltage.

### PIN CONNECTION AND IEC LOGIC SYMBOLS

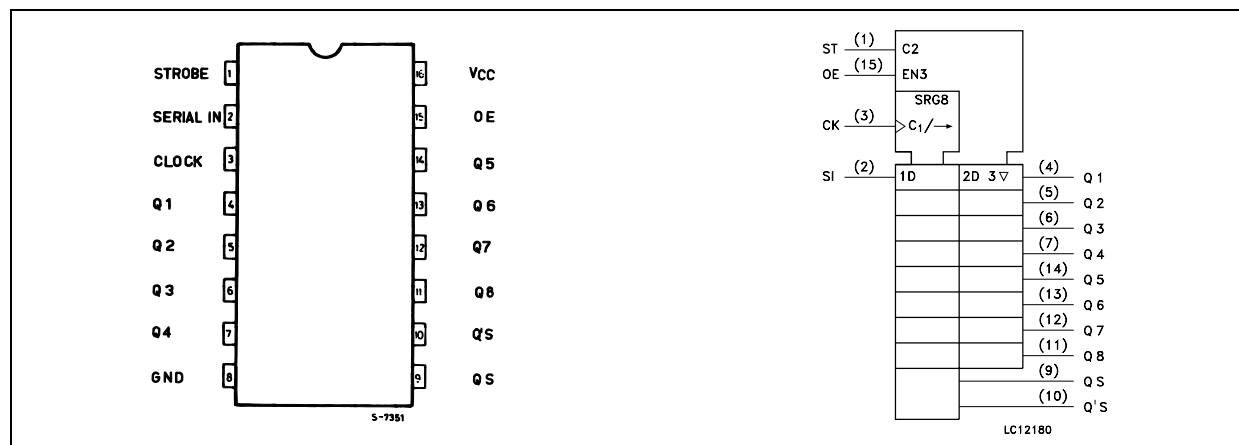

# M74HC4094

## INPUT AND OUTPUT EQUIVALENT CIRCUIT

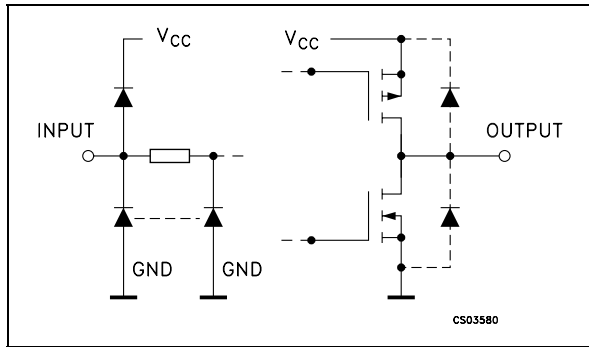

## PIN DESCRIPTION

PIN No	SYMBOL	NAME AND FUNCTION
1	STROBE	Strobe Input
2	SERIAL IN	Serial Input
3	CLOCK	Clock Input
4, 5, 6, 7, 14, 13, 12, 11	Q1 to Q7	Parallel Outputs
9, 10	QS Q'S	Serial Outputs
15	OE	Output Enable Input
8	GND	Ground (0V)
16	Vcc	Positive Supply Voltage

## TRUTH TABLE

CK	OE	ST	SI	PARALLEL OUTPUTS		SERIAL OUTPUTS	
				Q1	Qn	Qs	Qs'
	H	H	L	L	Qn-1	Q7	NC
	H	H	H	H	Qn-1	Q7	NC
	H	L	X	NC	NC	Q7	NC
	L	X	X	Z	Z	NC	Q8
	H	H	H	NC	NC	NC	Q8
	L	X	X	Z	Z	Q7	NC

X : Don't Care  
 Z : High Impedance  
 NC: No Change

## LOGIC DIAGRAM

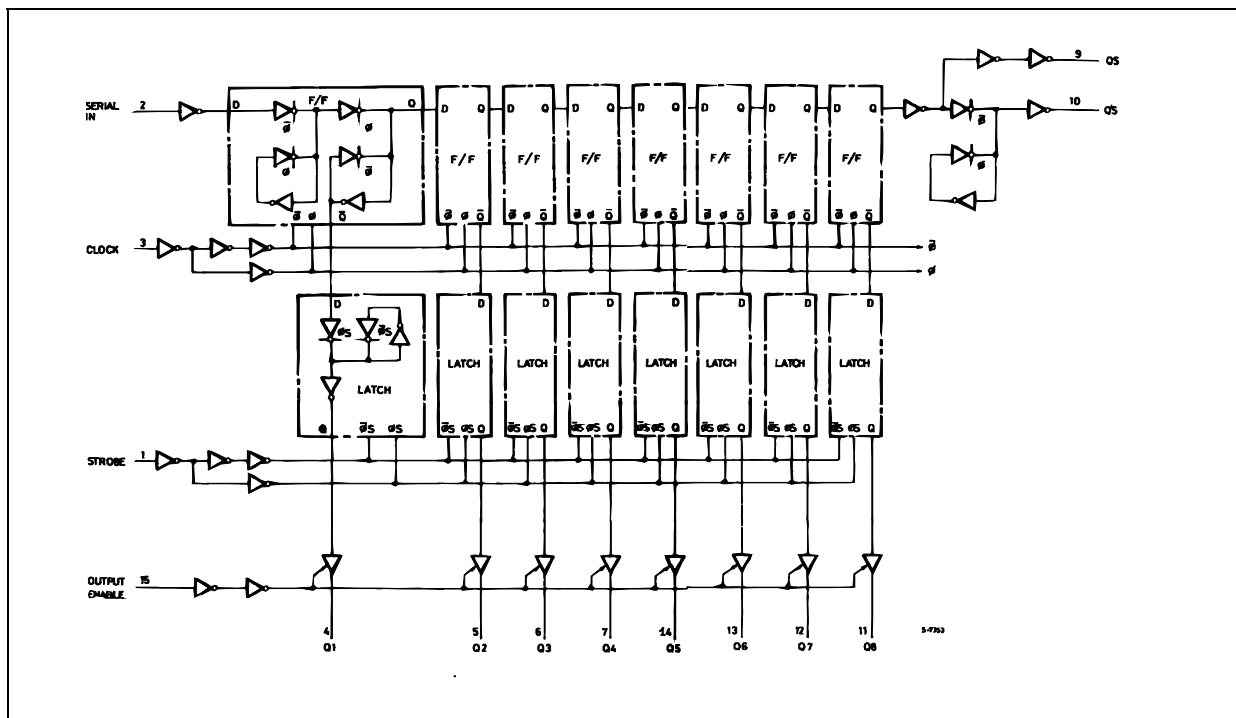

This logic diagram has not been used to estimate propagation delays

## TIMING CHART

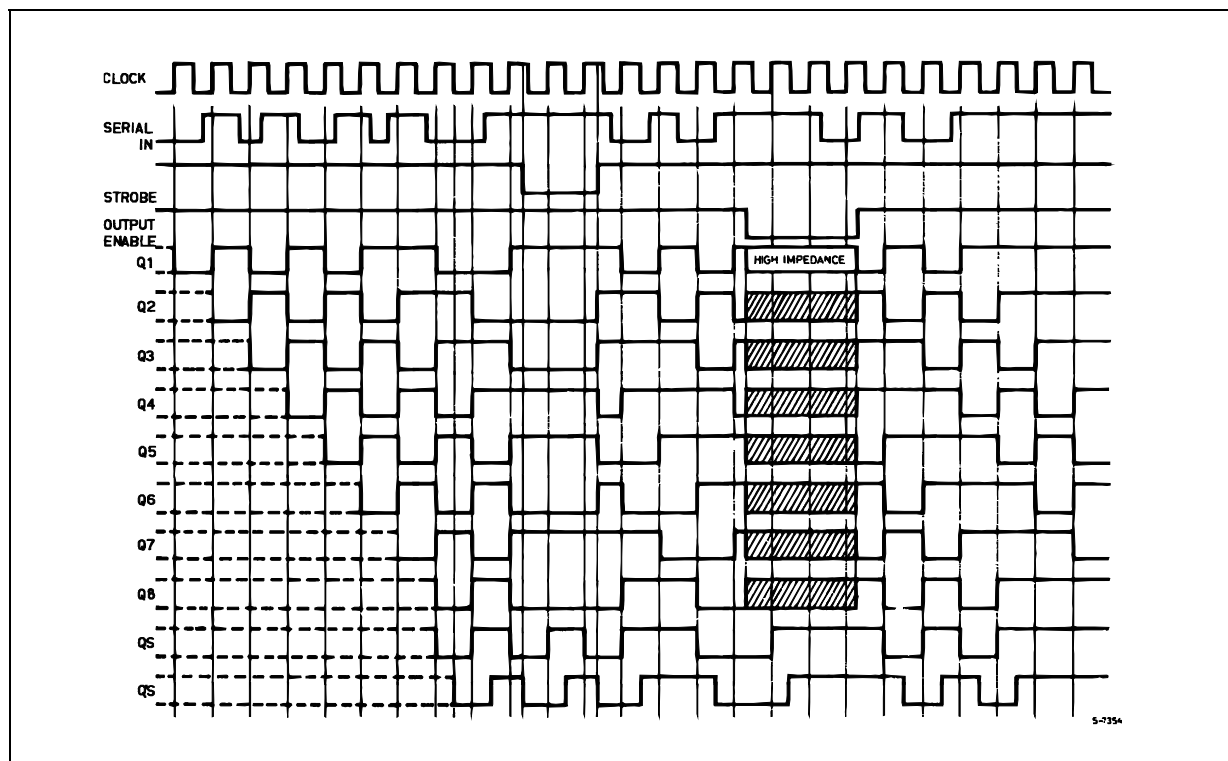

## ABSOLUTE MAXIMUM RATINGS

Symbol	Parameter	Value	Unit
$V_{CC}$	Supply Voltage	-0.5 to +7	V
$V_I$	DC Input Voltage	-0.5 to $V_{CC} + 0.5$	V
$V_O$	DC Output Voltage	-0.5 to $V_{CC} + 0.5$	V
$I_{IK}$	DC Input Diode Current	$\pm 20$	mA
$I_{OK}$	DC Output Diode Current	$\pm 20$	mA
$I_O$	DC Output Current	$\pm 25$	mA
$I_{CC}$ or $I_{GND}$	DC $V_{CC}$ or Ground Current	$\pm 50$	mA
$P_D$	Power Dissipation	500(*)	mW
$T_{stg}$	Storage Temperature	-65 to +150	$^{\circ}C$
$T_L$	Lead Temperature (10 sec)	300	$^{\circ}C$

Absolute Maximum Ratings are those values beyond which damage to the device may occur. Functional operation under these conditions is not implied.

(\*) 500mW at 65  $^{\circ}C$ ; derate to 300mW by 10mW/ $^{\circ}C$  from 65 $^{\circ}C$  to 85 $^{\circ}C$

## RECOMMENDED OPERATING CONDITIONS

Symbol	Parameter	Value	Unit	
$V_{CC}$	Supply Voltage	2 to 6	V	
$V_I$	Input Voltage	0 to $V_{CC}$	V	
$V_O$	Output Voltage	0 to $V_{CC}$	V	
$T_{op}$	Operating Temperature	-55 to 125	°C	
$t_r, t_f$	Input Rise and Fall Time	$V_{CC} = 2.0V$	0 to 1000	ns
		$V_{CC} = 4.5V$	0 to 500	ns
		$V_{CC} = 6.0V$	0 to 400	ns

## DC SPECIFICATIONS

Symbol	Parameter	Test Condition		Value						Unit	
		$V_{CC}$ (V)		$T_A = 25^\circ\text{C}$			-40 to 85°C		-55 to 125°C		
				Min.	Typ.	Max.	Min.	Max.	Min.		Max.
$V_{IH}$	High Level Input Voltage	2.0		1.5			1.5		1.5		V
		4.5		3.15			3.15		3.15		
		6.0		4.2			4.2		4.2		
$V_{IL}$	Low Level Input Voltage	2.0				0.5		0.5		0.5	V
		4.5				1.35		1.35		1.35	
		6.0				1.8		1.8		1.8	
$V_{OH}$	High Level Output Voltage	2.0	$I_O = -20 \mu\text{A}$	1.9	2.0		1.9		1.9		V
		4.5	$I_O = -20 \mu\text{A}$	4.4	4.5		4.4		4.4		
		6.0	$I_O = -20 \mu\text{A}$	5.9	6.0		5.9		5.9		
		4.5	$I_O = -4.0 \text{ mA}$	4.18	4.31		4.13		4.10		
		6.0	$I_O = -5.2 \text{ mA}$	5.68	5.8		5.63		5.60		
$V_{OL}$	Low Level Output Voltage	2.0	$I_O = 20 \mu\text{A}$		0.0	0.1		0.1		0.1	V
		4.5	$I_O = 20 \mu\text{A}$		0.0	0.1		0.1		0.1	
		6.0	$I_O = 20 \mu\text{A}$		0.0	0.1		0.1		0.1	
		4.5	$I_O = 4.0 \text{ mA}$		0.17	0.26		0.33		0.40	
		6.0	$I_O = 5.2 \text{ mA}$		0.18	0.26		0.33		0.40	
$I_I$	Input Leakage Current	6.0	$V_I = V_{CC}$ or GND			$\pm 0.1$		$\pm 1$		$\pm 1$	$\mu\text{A}$
$I_{OZ}$	High Impedance Output Leakage Current	6.0	$V_I = V_{IH}$ or $V_{IL}$ $V_O = V_{CC}$ or GND			$\pm 0.5$		$\pm 5$		$\pm 10$	$\mu\text{A}$
$I_{CC}$	Quiescent Supply Current	6.0	$V_I = V_{CC}$ or GND			4		40		80	$\mu\text{A}$

AC ELECTRICAL CHARACTERISTICS ( $C_L = 50 \text{ pF}$ , Input  $t_r = t_f = 6 \text{ ns}$ )

Symbol	Parameter	Test Condition		Value						Unit	
		$V_{CC}$ (V)		$T_A = 25^\circ\text{C}$			$-40 \text{ to } 85^\circ\text{C}$		$-55 \text{ to } 125^\circ\text{C}$		
				Min.	Typ.	Max.	Min.	Max.	Min.		Max.
$t_{TLH}$ $t_{THL}$	Output Transition Time	2.0			30	75		95		115	ns
		4.5			8	15		19		23	
		6.0			7	13		16		20	
$t_{PLH}$ $t_{PHL}$	Propagation Delay Time (CLOCK - Qn)	2.0			92	200		250		300	ns
		4.5			26	40		50		60	
		6.0			20	34		43		51	
$t_{PLH}$ $t_{PHL}$	Propagation Delay Time (CLOCK - QS, Q'S)	2.0			65	150		190		225	ns
		4.5			19	30		38		45	
		6.0			15	26		32		38	
$t_{PLH}$ $t_{PHL}$	Propagation Delay Time (STROBE - Qn)	2.0			75	160		200		240	ns
		4.5			20	32		40		48	
		6.0			16	27		34		41	
$t_{PZL}$ $t_{PZH}$	High Impedance Output Enable Time	2.0			58	150		190		225	ns
		4.5			16	30		38		45	
		6.0			13	26		32		38	
$t_{PHZ}$ $t_{PLZ}$	High Impedance Output Disable Time	2.0			35	150		190		225	ns
		4.5			16	30		38		45	
		6.0			13	26		32		38	
$f_{MAX}$	Maximum Clock Frequency	2.0			6	16		4.8		4	MHz
		4.5			30	66		24		20	
		6.0			35	80		28		24	
$t_{W(H)}$ $t_{W(L)}$	Minimum Pulse Width	2.0			17	75		95		110	ns
		4.5			7	15		19		22	
		6.0			6	13		16		19	
$t_{W(L)}$	Minimum Pulse Width	2.0			28	75		95		110	ns
		4.5			6	15		19		22	
		6.0			6	13		16		19	
$t_s$	Minimum Set-up Time (SERIAL INPUT)	2.0			30	75		95		110	ns
		4.5			7	15		19		22	
		6.0			5	13		16		19	
$t_s$	Minimum Set-up Time (STROBE)	2.0			45	100		125		145	ns
		4.5			10	20		25		29	
		6.0			8	17		21		25	
$t_h$	Minimum Hold Time (SI, ST)	2.0				0		0		0	ns
		4.5				0		0		0	
		6.0				0		0		0	

**CAPACITIVE CHARACTERISTICS**

Symbol	Parameter	Test Condition		Value						Unit	
		V <sub>CC</sub> (V)		T <sub>A</sub> = 25°C			-40 to 85°C		-55 to 125°C		
				Min.	Typ.	Max.	Min.	Max.	Min.		Max.
C <sub>IN</sub>	Input Capacitance	5.0			5	10		10		10	pF
C <sub>PD</sub>	Power Dissipation Capacitance (note 1)	5.0			140						pF

1) C<sub>PD</sub> is defined as the value of the IC's internal equivalent capacitance which is calculated from the operating current consumption without load. (Refer to Test Circuit). Average operating current can be obtained by the following equation. I<sub>CC(opr)</sub> = C<sub>PD</sub> × V<sub>CC</sub> × f<sub>IN</sub> + I<sub>CC</sub>/2 (per FLIP/FLOP)

**TEST CIRCUIT**

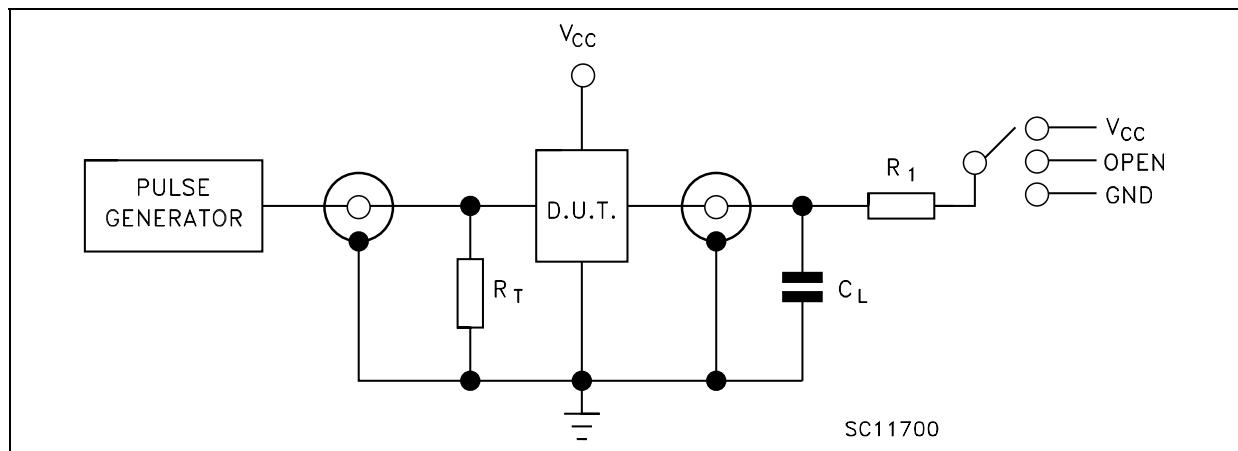

TEST	SWITCH
t <sub>PLH</sub> , t <sub>PHL</sub>	Open
t <sub>PZL</sub> , t <sub>PLZ</sub>	V <sub>CC</sub>
t <sub>PZH</sub> , t <sub>PHZ</sub>	GND

C<sub>L</sub> = 50pF/150pF or equivalent (includes jig and probe capacitance)  
 R<sub>1</sub> = 1KΩ or equivalent  
 R<sub>T</sub> = Z<sub>OUT</sub> of pulse generator (typically 50Ω)

**WAVEFORM 1: PROPAGATION DELAY TIMES, MINIMUM PULSE WIDTH (CLOCK), SETUP AND HOLD TIMES (CLOCK)** (f=1MHz; 50% duty cycle)

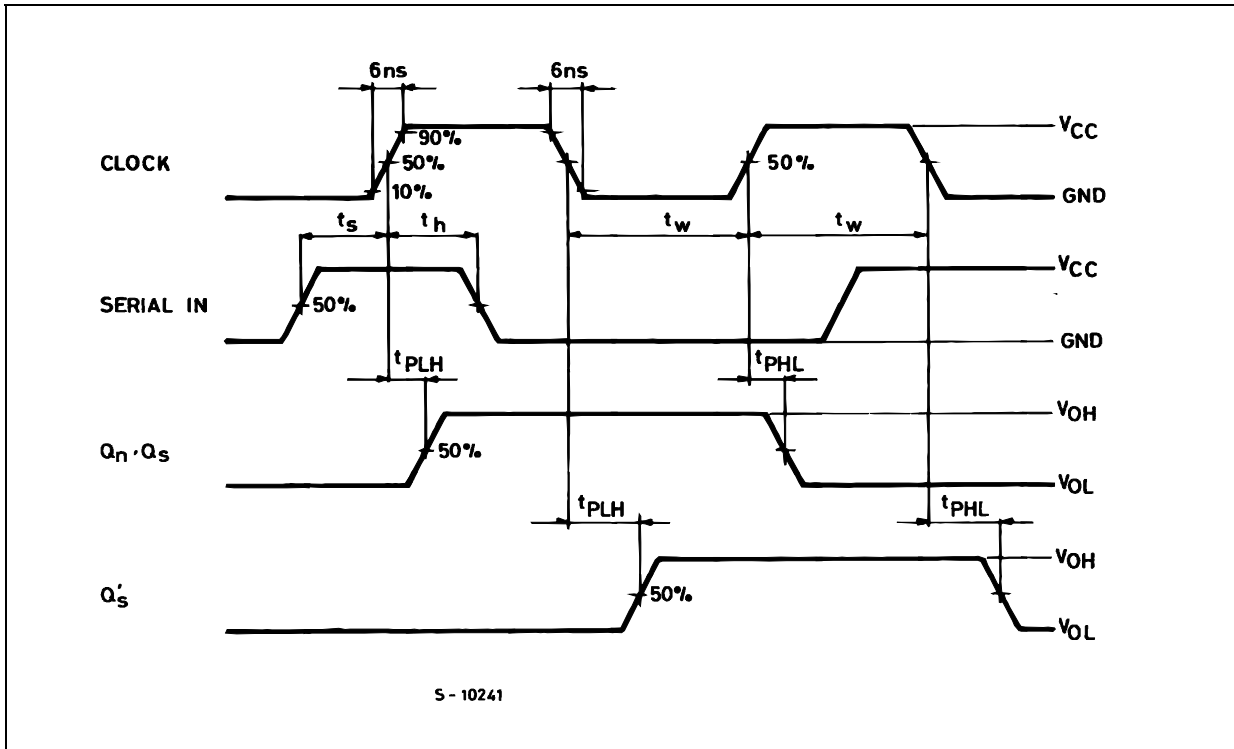

**WAVEFORM 2 :PROPAGATION DELAY TIMES, MINIMUM PULSE WIDTH (STROBE), SETUP AND HOLD TIMES (STROBE)**(f=1MHz; 50% duty cycle)

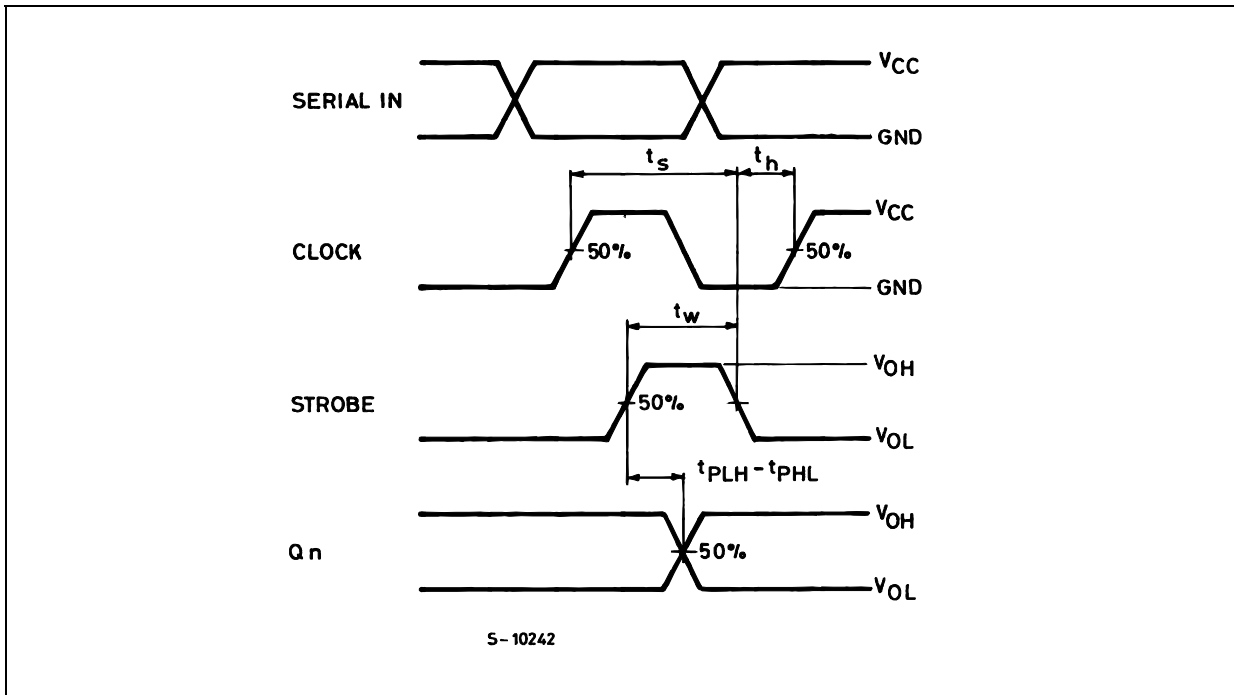

WAVEFORM 3 : OUTPUT ENABLE AND DISABLE TIMES(f=1MHz; 50% duty cycle)

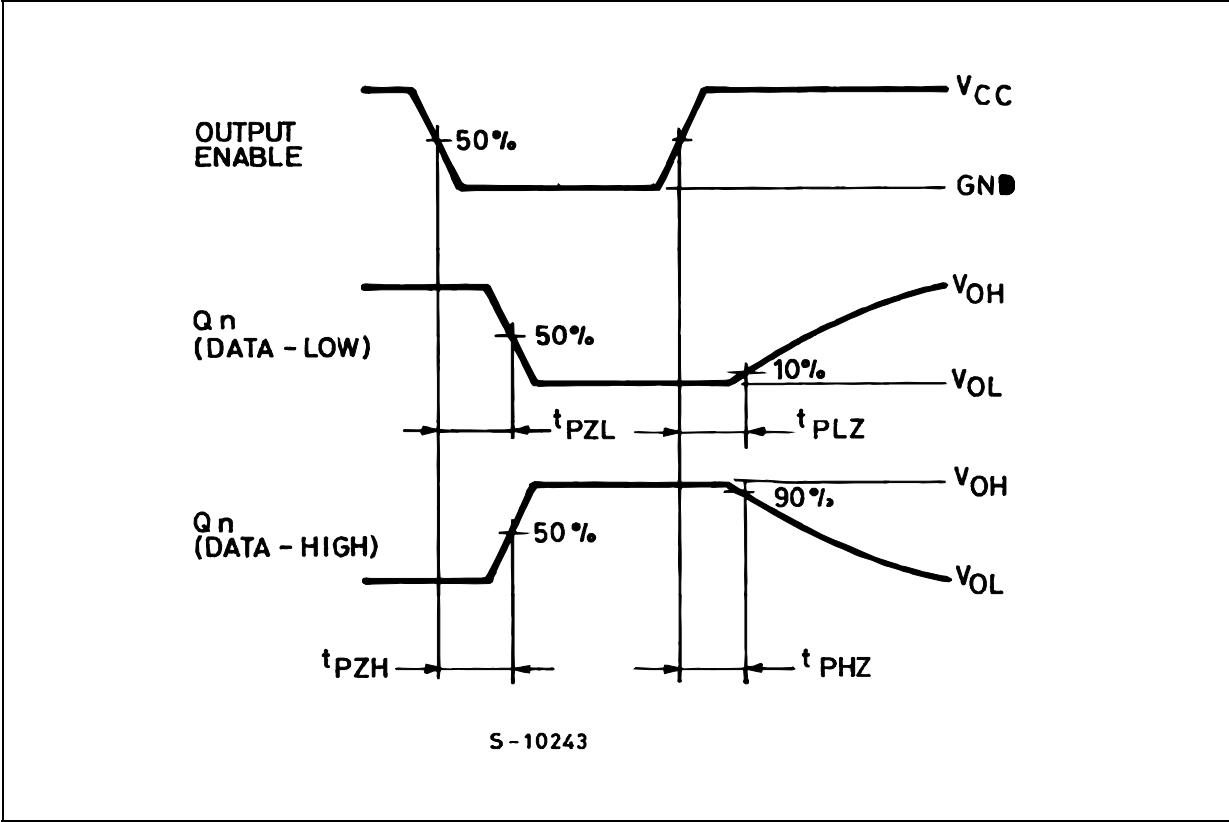



### Plastic DIP-16 (0.25) MECHANICAL DATA

DIM.	mm.			inch		
	MIN.	TYP	MAX.	MIN.	TYP.	MAX.
a1	0.51			0.020		
B	0.77		1.65	0.030		0.065
b		0.5			0.020	
b1		0.25			0.010	
D			20			0.787
E		8.5			0.335	
e		2.54			0.100	
e3		17.78			0.700	
F			7.1			0.280
I			5.1			0.201
L		3.3			0.130	
Z			1.27			0.050

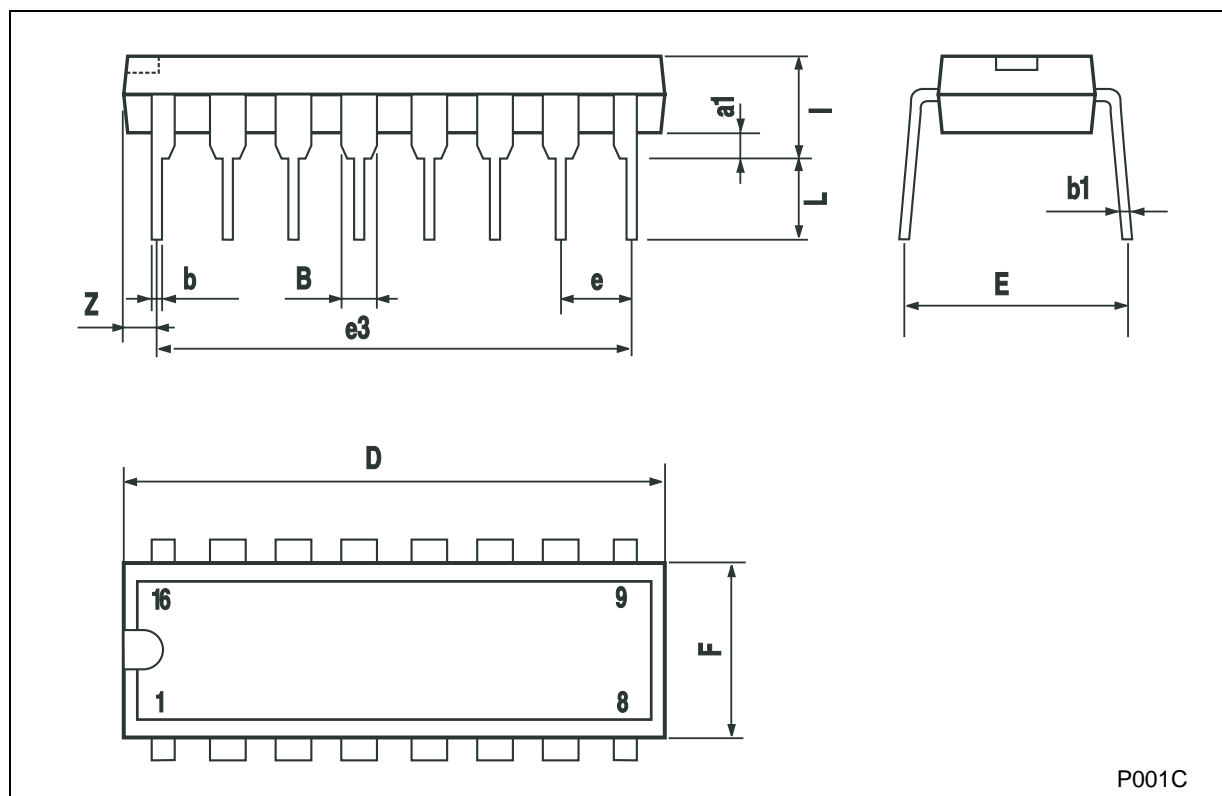

P001C

**SO-16 MECHANICAL DATA**

DIM.	mm.			inch		
	MIN.	TYP.	MAX.	MIN.	TYP.	MAX.
A			1.75			0.068
a1	0.1		0.2	0.004		0.008
a2			1.65			0.064
b	0.35		0.46	0.013		0.018
b1	0.19		0.25	0.007		0.010
C		0.5			0.019	
c1	45° (typ.)					
D	9.8		10	0.385		0.393
E	5.8		6.2	0.228		0.244
e		1.27			0.050	
e3		8.89			0.350	
F	3.8		4.0	0.149		0.157
G	4.6		5.3	0.181		0.208
L	0.5		1.27	0.019		0.050
M			0.62			0.024
S	8			° (max.)		

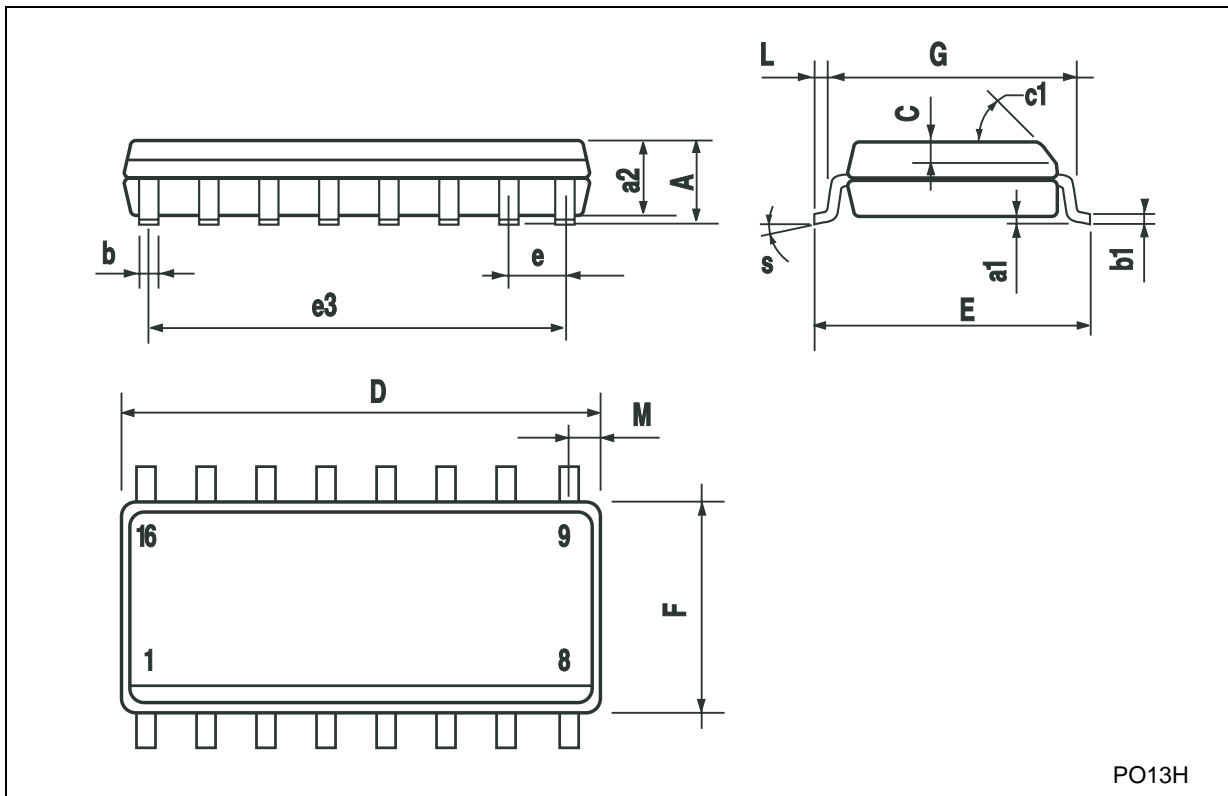

PO13H

## TSSOP16 MECHANICAL DATA

DIM.	mm.			inch		
	MIN.	TYP	MAX.	MIN.	TYP.	MAX.
A			1.2			0.047
A1	0.05		0.15	0.002	0.004	0.006
A2	0.8	1	1.05	0.031	0.039	0.041
b	0.19		0.30	0.007		0.012
c	0.09		0.20	0.004		0.0079
D	4.9	5	5.1	0.193	0.197	0.201
E	6.2	6.4	6.6	0.244	0.252	0.260
E1	4.3	4.4	4.48	0.169	0.173	0.176
e		0.65 BSC			0.0256 BSC	
K	0°		8°	0°		8°
L	0.45	0.60	0.75	0.018	0.024	0.030

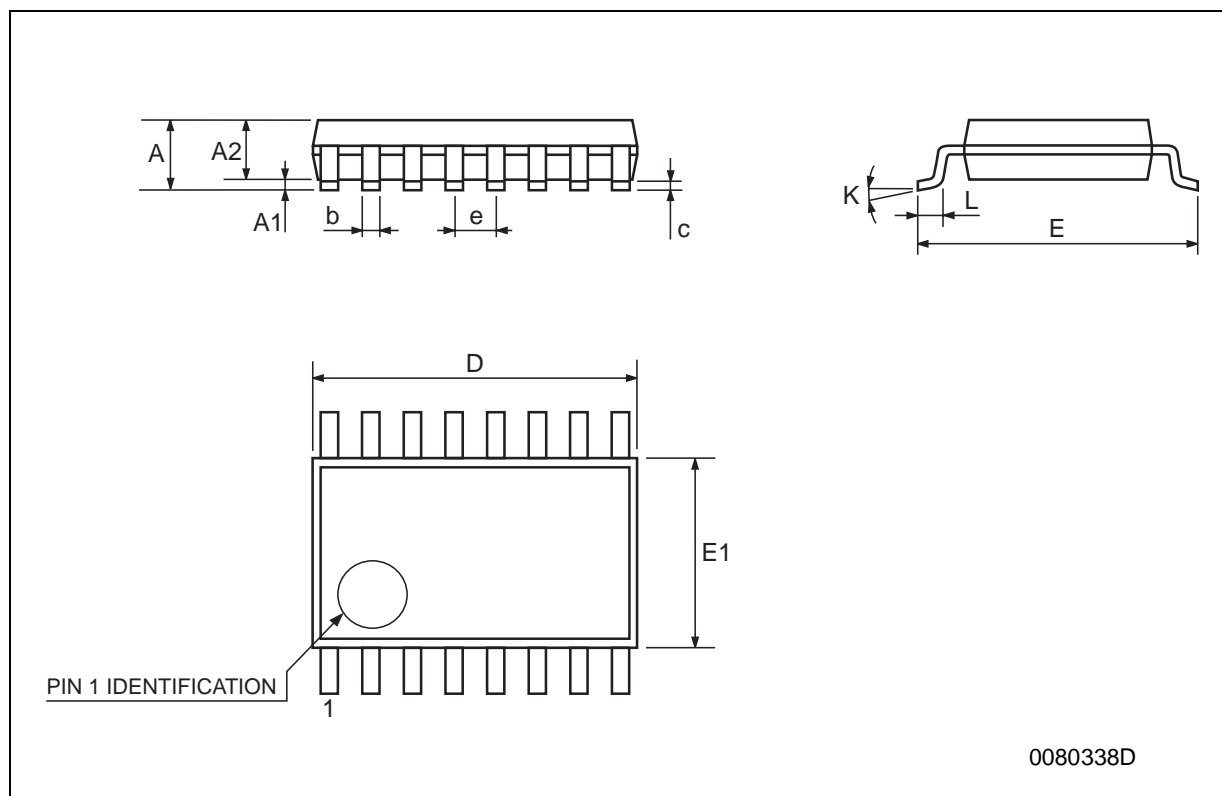

Information furnished is believed to be accurate and reliable. However, STMicroelectronics assumes no responsibility for the consequences of use of such information nor for any infringement of patents or other rights of third parties which may result from its use. No license is granted by implication or otherwise under any patent or patent rights of STMicroelectronics. Specifications mentioned in this publication are subject to change without notice. This publication supersedes and replaces all information previously supplied. STMicroelectronics products are not authorized for use as critical components in life support devices or systems without express written approval of STMicroelectronics.

© The ST logo is a registered trademark of STMicroelectronics

© 2003 STMicroelectronics - Printed in Italy - All Rights Reserved  
STMicroelectronics GROUP OF COMPANIES

Australia - Brazil - Canada - China - Finland - France - Germany - Hong Kong - India - Israel - Italy - Japan - Malaysia - Malta - Morocco  
Singapore - Spain - Sweden - Switzerland - United Kingdom - United States.

© <http://www.st.com>