



M74HC4052

DUAL 4-CHANNEL ANALOG MULTIPLEXER/DEMULTIPLEXER

- **LOW POWER DISSIPATION:**
 $I_{CC} = 4\mu\text{A}(\text{MAX.})$ at $T_A = 25^\circ\text{C}$
- **LOGIC LEVEL TRANSLATION TO ENABLE 5V LOGIC SIGNAL TO COMMUNICATE WITH $\pm 5\text{V}$ ANALOG SIGNAL**
- **LOW "ON" RESISTANCE:**
 70Ω TYP. ($V_{CC} - V_{EE} = 4.5\text{V}$)
 50Ω TYP. ($V_{CC} - V_{EE} = 9\text{V}$)
- **WIDE ANALOG INPUT VOLTAGE RANGE:**
 $\pm 6\text{V}$
- **FAST SWITCHING:**
 $t_{pd} = 15\text{ns}$ (TYP.) at $T_A = 25^\circ\text{C}$
- **LOW CROSSTALK BETWEEN SWITCHES**
- **HIGH ON/OFF OUTPUT VOLTAGE RATIO**
- **WIDE OPERATING SUPPLY VOLTAGE RANGE** ($V_{CC} - V_{EE}$) = $2\text{V TO } 12\text{V}$
- **LOW SINE WAVE DISTORTION:**
 0.02% at $V_{CC} - V_{EE} = 9\text{V}$
- **HIGH NOISE IMMUNITY:**
 $V_{NIH} = V_{NIL} = 28\% V_{CC}$ (MIN.)
- **PIN AND FUNCTION COMPATIBLE WITH 74 SERIES 4052**



ORDER CODES

PACKAGE	TUBE	T & R
DIP	M74HC4052B1R	
SOP	M74HC4052M1R	M74HC4052RM13TR
TSSOP		M74HC4052TTR

It contains 8 bidirectional and digitally controlled analog switches.

A built-in level shifting is included to allow an input range up to $\pm 6\text{V}$ (peak) for an analog signal with digital control signal of 0 to 6V.

V_{EE} supply pin is provided for analog input signals. It has an inhibit (INH) input terminal to disable all the switches when high. For operation as a digital multiplexer/demultiplexer, V_{EE} is connected to GND.

A and B control inputs select one channel out of four in each section.

All inputs are equipped with protection circuits against static discharge and transient excess voltage.

DESCRIPTION

The M74HC4052 is a dual four-channel analog MULTIPLEXER/DEMULTIPLEXER fabricated with silicon gate $C^2\text{MOS}$ technology and it is pin to pin compatible with the equivalent metal gate CMOS4000B series.

PIN CONNECTION AND IEC LOGIC SYMBOLS

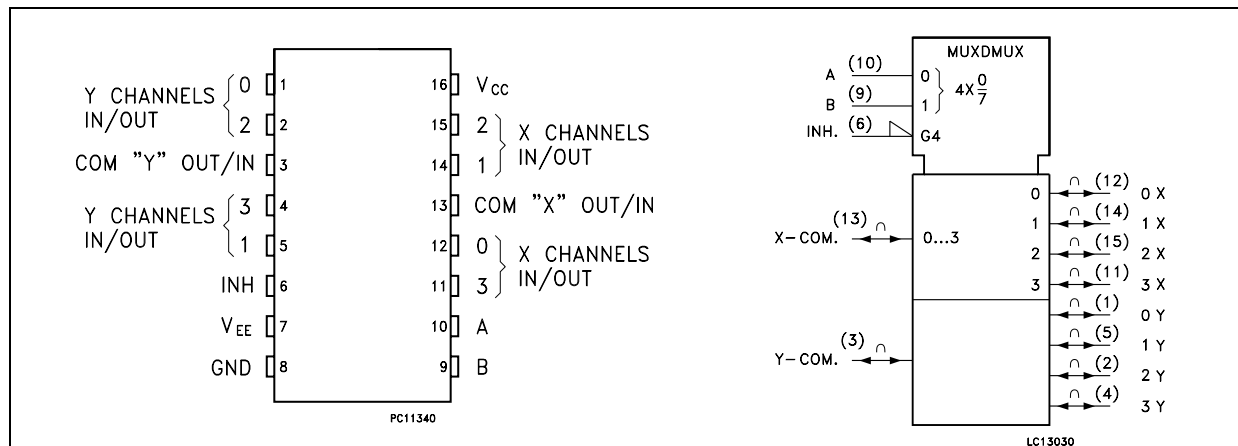

CONTROL INPUT EQUIVALENT CIRCUIT

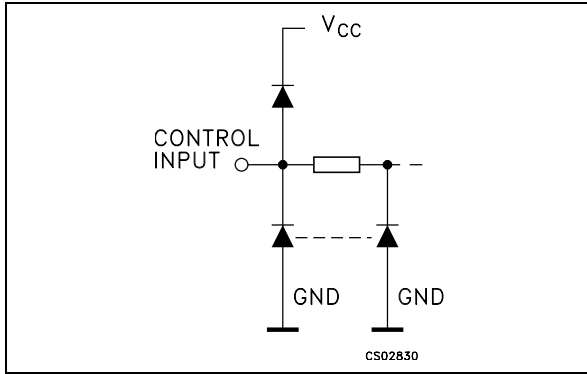

I/O EQUIVALENT CIRCUIT

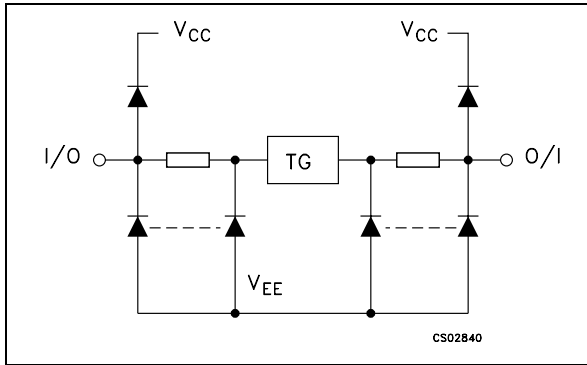

PIN DESCRIPTION

PIN No	SYMBOL	NAME AND FUNCTION
1, 5, 2, 4	0Y to 3Y	Independent Input Outputs
6	INH	INHIBIT Input
7	V _{EE}	Negative Supply Voltage
10, 9	A, B	Select Inputs
12, 14, 15, 11	0X to 3X	Independent Input Outputs
3	COM Y OUT/IN	Common X Output/Input
13	COM Y OUT/IN	Common Y Output/Input
8	GND	Ground (0V)
16	V _{CC}	Positive Supply Voltage

TRUTH TABLE

INPUT STATE			ON CHANNEL
INH	B	A	
L	L	L	0X, 0Y
L	L	H	1X, 1Y
L	H	L	2X, 2Y
L	H	H	3X, 3Y
H	X	X	NONE

X: Don't care

FUNCTIONAL DIAGRAM

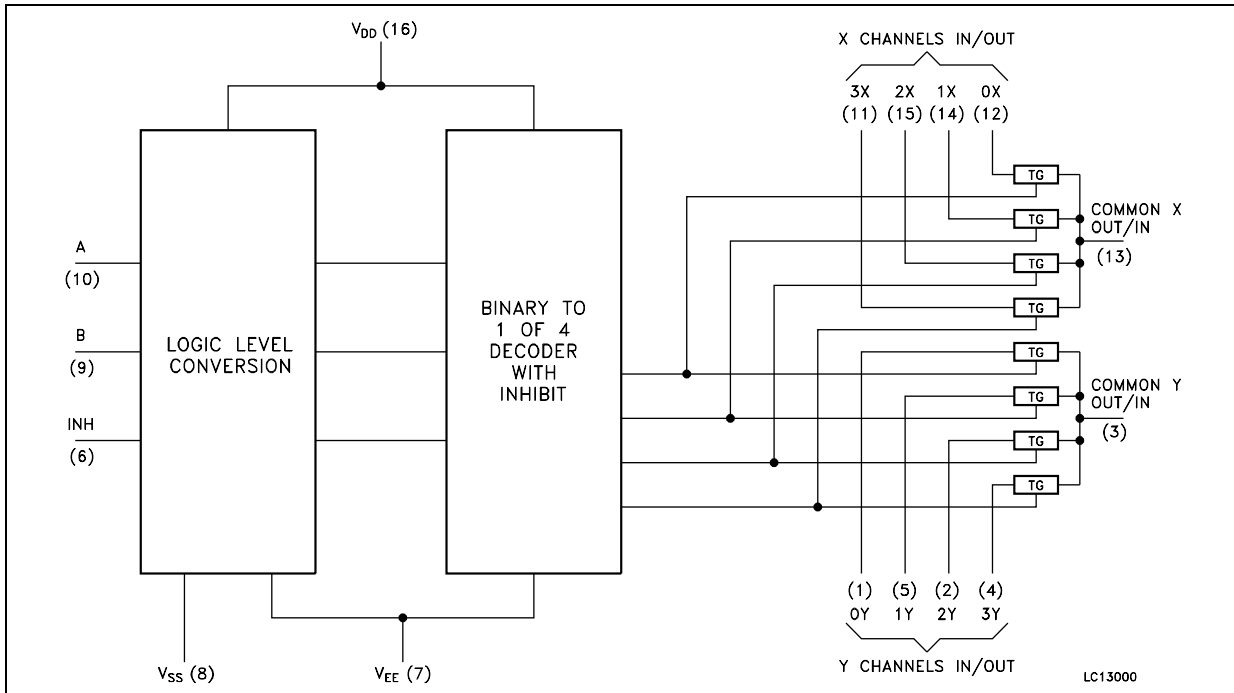

ABSOLUTE MAXIMUM RATINGS

Symbol	Parameter	Value	Unit
V_{CC}	Supply Voltage	-0.5 to +7	V
$V_{CC} - V_{EE}$	Supply Voltage	-0.5 to +13	V
V_I	Control Input Voltage	-0.5 to $V_{CC} + 0.5$	V
$V_{I/O}$	Switch I/O Voltage	$V_{EE} - 0.5$ to $V_{CC} + 0.5$	V
I_{CK}	Control Input Diode Current	± 20	mA
$I_{I/OK}$	I/O Diode Current	± 20	mA
I_T	Switch Through Current	± 25	mA
I_{CC} or I_{GND}	DC V_{CC} or Ground Current	± 50	mA
P_D	Power Dissipation	500(*)	mW
T_{stg}	Storage Temperature	-65 to +150	°C
T_L	Lead Temperature (10 sec)	300	°C

Absolute Maximum Ratings are those values beyond which damage to the device may occur. Functional operation under these conditions is not implied

(*) 500mW at 65 °C; derate to 300mW by 10mW/°C from 65°C to 85°C

RECOMMENDED OPERATING CONDITIONS

Symbol	Parameter	Value	Unit	
V_{CC}	Supply Voltage	2 to 6	V	
V_{EE}	Supply Voltage	-6 to 0	V	
$V_{CC} - V_{EE}$	Supply Voltage	2 to 12	V	
V_I	Input Voltage	0 to V_{CC}	V	
$V_{I/O}$	I/O Voltage	V_{EE} to V_{CC}	V	
T_{op}	Operating Temperature	-55 to 125	°C	
t_r, t_f	Input Rise and Fall Time	$V_{CC} = 2.0V$	0 to 1000	ns
		$V_{CC} = 4.5V$	0 to 500	
		$V_{CC} = 6.0V$	0 to 400	

DC SPECIFICATIONS

Symbol	Parameter	Test Condition			Value						Unit	
		V _{CC} (V)	V _{EE} (V)		T _A = 25°C			-40 to 85°C		-55 to 125°C		
					Min.	Typ.	Max.	Min.	Max.	Min.		Max.
V _{IHC}	High Level Input Voltage	2.0			1.5			1.5		1.5		V
		4.5			3.15			3.15		3.15		
		6.0			4.2			4.2		4.2		
V _{ILC}	Low Level Input Voltage	2.0					0.5		0.5		0.5	V
		4.5					1.35		1.35		1.35	
		6.0					1.8		1.8		1.8	
R _{ON}	ON Resistance	4.5	GND	V _I = V _{IHC} or V _{ILC}		85	180		225		270	Ω
		4.5	-4.5	V _{I/O} = V _{CC} to V _{EE}		55	120		150		180	
		6.0	-6.0	I _{I/O} ≤ 2mA		50	100		125		150	
		2.0	GND	V _I = V _{IHC} or V _{ILC}		150						
		4.5	GND	V _{I/O} = V _{CC} or V _{EE}		70	150		190		230	
		4.5	-4.5	I _{I/O} ≤ 2mA		50	100		125		150	
ΔR _{ON}	Difference of ON Resistance between switches	4.5	GND	V _I = V _{IHC} or V _{ILC}		10	30		35		45	Ω
		4.5	-4.5	V _{I/O} = V _{CC} or V _{EE}		5	12		15		18	
		6.0	-6.0	I _{I/O} ≤ 2mA		5	10		12		15	
I _{OFF}	Input/Output Leakage Current (SWITCH OFF)	6.0	GND	V _{OS} = V _{CC} or GND			±0.06		± 0.6		± 1.2	μA
		6.0	-6.0	V _{IS} = GND or V _{CC} V _I = V _{ILC} or V _{IHC}			± 0.1		± 1		± 2	
I _{Iz}	Switch Input Leakage Current (SWITCH ON, OUTPUT OPEN)	6.0	GND	V _{OS} = V _{CC} or GND			±0.06		± 0.6		± 1.2	μA
		6.0	-6.0	V _I = V _{IHC} or V _{ILC}			± 0.1		± 1		± 2	
I _I	Input Leakage Current	6.0	GND	V _I = V _{CC} or GND			± 0.1		± 0.1		± 1	μA
I _{CC}	Quiescent Supply Current	6.0	GND	V _I = V _{CC} or GND			4		40		80	μA
		6.0	-6.0				8		80		160	

AC ELECTRICAL CHARACTERISTICS ($C_L = 50 \text{ pF}$, Input $t_r = t_f = 6 \text{ ns}$)

Symbol	Parameter	Test Condition			Value						Unit	
		V_{CC} (V)	V_{EE} (V)		$T_A = 25^\circ\text{C}$			$-40 \text{ to } 85^\circ\text{C}$		$-55 \text{ to } 125^\circ\text{C}$		
					Min.	Typ.	Max.	Min.	Max.	Min.		Max.
$\Phi_{I/O}$	Phase Difference Between Input and Output	2.0	GND			25	60		75		90	ns
		4.5	GND			6	12		15		18	
		6.0	GND			5	10		13		15	
		4.5	-4.5			4						
t_{PZL} t_{PZH}	Output Enable Time	2.0	GND	$R_L = 1\text{K}\Omega$		64	225		280		340	ns
		4.5	GND			18	45		56		68	
		6.0	GND			15	38		48		58	
		4.5	-4.5			18						
t_{PLZ} t_{PHZ}	Output Disable Time	2.0	GND	$R_L = 1\text{K}\Omega$		100	250		315		375	ns
		4.5	GND			33	50		63		70	
		6.0	GND			28	43		54		64	
		4.5	-4.5			29						

CAPACITIVE CHARACTERISTICS

Symbol	Parameter	Test Condition			Value						Unit	
		V_{CC} (V)	V_{EE} (V)		$T_A = 25^\circ\text{C}$			$-40 \text{ to } 85^\circ\text{C}$		$-55 \text{ to } 125^\circ\text{C}$		
					Min.	Typ.	Max.	Min.	Max.	Min.		Max.
C_{IN}	Input Capacitance	5.0				5	10		10		10	pF
$C_{I/O}$	Common Terminal Capacitance	5.0	-5.0			19	40		40		40	pF
$C_{I/O}$	Switch Terminal Capacitance	5.0	-5.0			7	15		15		15	pF
C_{IOS}	Feed Through Capacitance	5.0	-5.0			0.85	2		2		2	pF
C_{PD}	Power Dissipation Capacitance (note 1)	5.0	GND			71						pF

1) C_{PD} is defined as the value of the IC's internal equivalent capacitance which is calculated from the operating current consumption without load. (Refer to Test Circuit). Average operating current can be obtained by the following equation. $I_{CC(opr)} = C_{PD} \times V_{CC} \times f_{IN} + I_{CC}$

ANALOG SWITCH CHARACTERISTICS (GND = 0V; T_A = 25°C)

Symbol	Parameter	Test Condition			Value	Unit
		V _{CC} (V)	V _{EE} (V)	V _{IN} (V _{p-p})		
	Sine Wave Distortion	2.25	-2.25	4	0.025	%
		4.5	-4.5	8	0.020	
		6.0	-6.0	11	0.018	
f _{MAX}	Frequency Response (Switch ON) (*)	2.25	-2.25	Adjust f _{IN} voltage to obtain 0 dBm at V _{OS} . Increase f _{IN} Frequency until dB meter reads -3dB R _L = 50Ω, C _L = 10 pF, f _{IN} = 1KHz sine wave	120	MHz
		4.5	-4.5		190	
		6.0	-6.0		200	
f _{MAX}	Frequency Response (Switch ON) (**)	2.25	-2.25	Adjust f _{IN} voltage to obtain 0 dBm at V _{OS} . Increase f _{IN} Frequency until dB meter reads -3dB R _L = 50Ω, C _L = 10 pF, f _{IN} = 1KHz sine wave	70	MHz
		4.5	-4.5		110	
		6.0	-6.0		140	
	Feedthrough Attenuation (Switch OFF)	2.25	-2.25	V _{IN} is centered at (V _{CC} - V _{EE})/2 Adjust input for 0 dBm R _L = 600Ω, C _L = 50 pF, f _{IN} = 1KHz sine wave	-50	dB
		4.5	-4.5		-50	
		6.0	-6.0		-50	
	Crosstalk (Control Input to Signal Output)	2.25	-2.25	Adjust R _L at set up so that I _S = 0A. R _L = 600Ω, C _L = 50 pF, f _{IN} = 1KHz square wave	60	mV
		4.5	-4.5		140	
		6.0	-6.0		200	
	Crosstalk (between any two Switches)	2.25	-2.25	Adjust V _{IN} to obtain 0dBm at input R _L = 600Ω, C _L = 50 pF, f _{IN} = 1KHz sine wave	-50	dB
		4.5	-4.5		-50	
		6.0	-6.0		-50	

(*) Input COMMON Terminal, and measured at SWITCH Terminal

(**) Input SWITCH Terminal, and measured at common Terminal

NOTE: These characteristics are determined by the design of the device.

SWITCHING CHARACTERISTICS TEST CIRCUIT

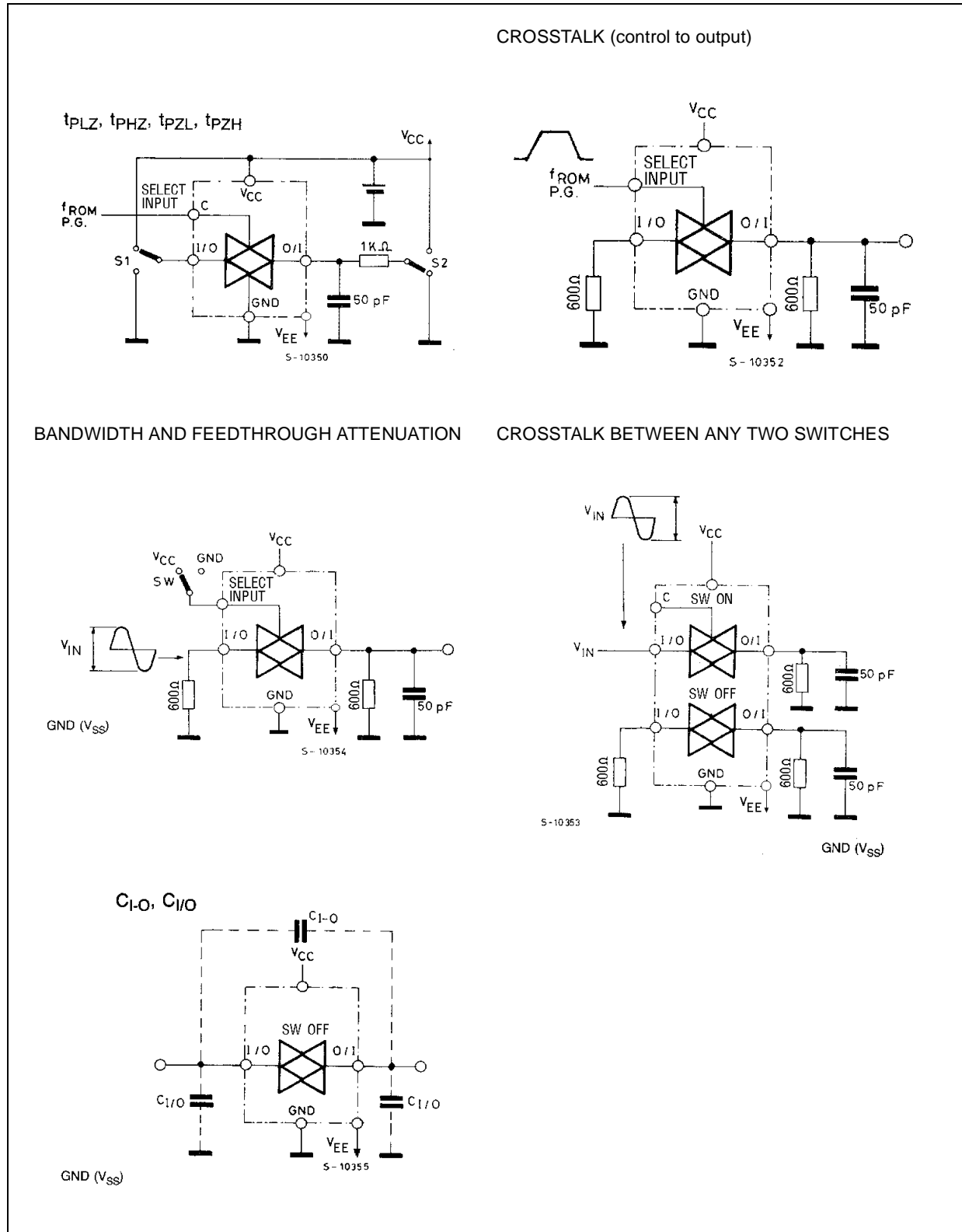

SWITCHING CHARACTERISTICS WAVEFORM

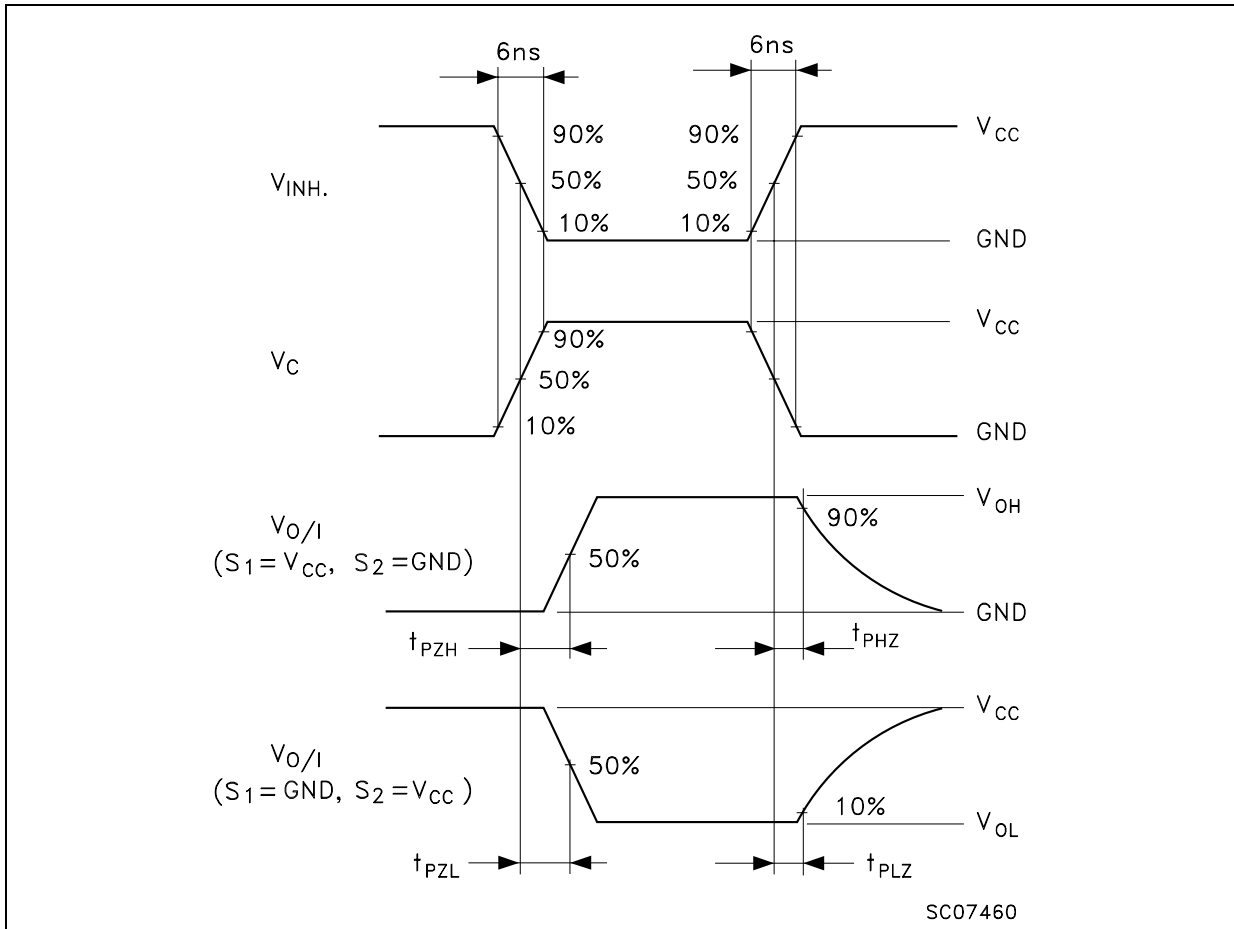

CHANNEL RESISTANCE (R_{ON})

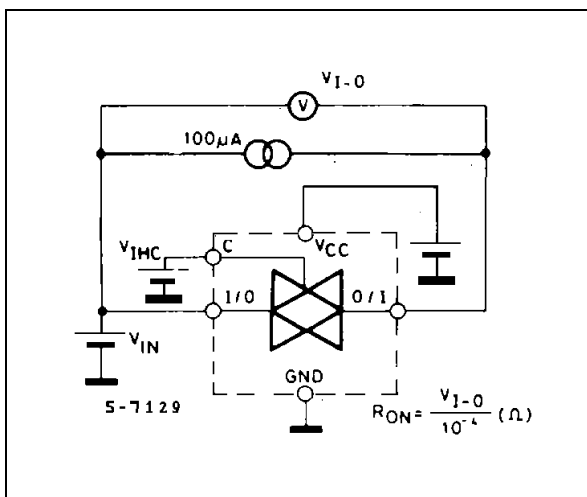

I_{CC} (Opr.)

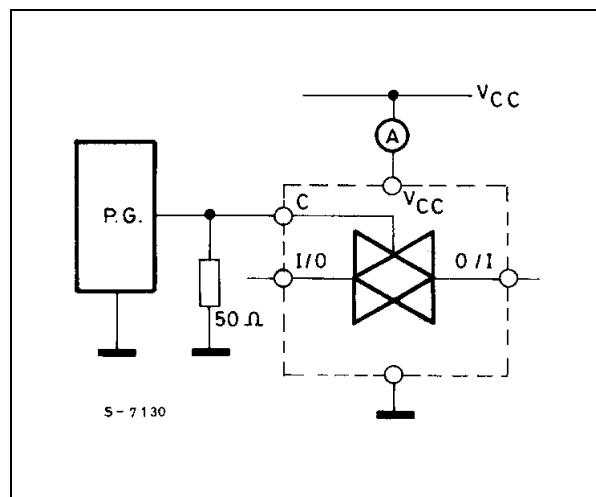

Plastic DIP-16 (0.25) MECHANICAL DATA

DIM.	mm.			inch		
	MIN.	TYP	MAX.	MIN.	TYP.	MAX.
a1	0.51			0.020		
B	0.77		1.65	0.030		0.065
b		0.5			0.020	
b1		0.25			0.010	
D			20			0.787
E		8.5			0.335	
e		2.54			0.100	
e3		17.78			0.700	
F			7.1			0.280
I			5.1			0.201
L		3.3			0.130	
Z			1.27			0.050

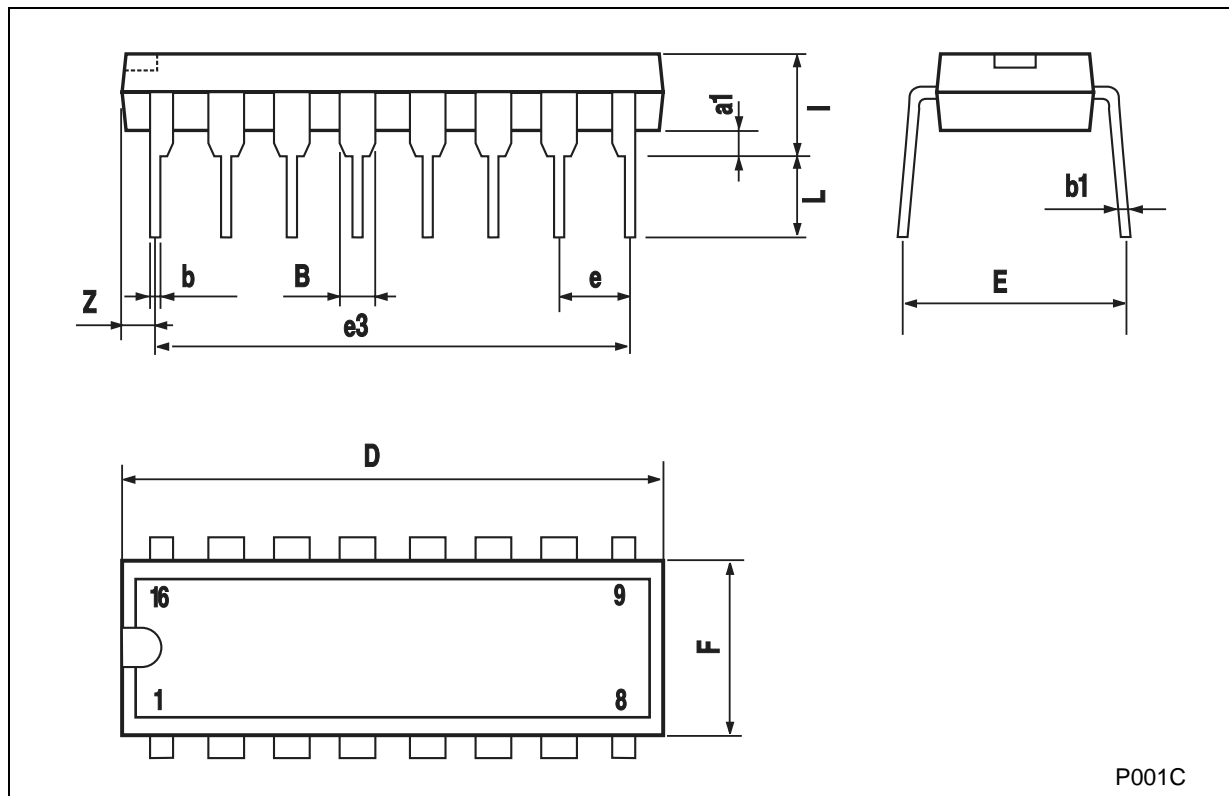

SO-16 MECHANICAL DATA

DIM.	mm.			inch		
	MIN.	TYP.	MAX.	MIN.	TYP.	MAX.
A			1.75			0.068
a1	0.1		0.2	0.003		0.007
a2			1.65			0.064
b	0.35		0.46	0.013		0.018
b1	0.19		0.25	0.007		0.010
C		0.5			0.019	
c1	45° (typ.)					
D	9.8		10	0.385		0.393
E	5.8		6.2	0.228		0.244
e		1.27			0.050	
e3		8.89			0.350	
F	3.8		4.0	0.149		0.157
G	4.6		5.3	0.181		0.208
L	0.5		1.27	0.019		0.050
M			0.62			0.024
S	8° (max.)					



PO13H

TSSOP16 MECHANICAL DATA

DIM.	mm.			inch		
	MIN.	TYP.	MAX.	MIN.	TYP.	MAX.
A			1.2			0.047
A1	0.05		0.15	0.002	0.004	0.006
A2	0.8	1	1.05	0.031	0.039	0.041
b	0.19		0.30	0.007		0.012
c	0.09		0.20	0.004		0.0089
D	4.9	5	5.1	0.193	0.197	0.201
E	6.2	6.4	6.6	0.244	0.252	0.260
E1	4.3	4.4	4.48	0.169	0.173	0.176
e		0.65 BSC			0.0256 BSC	
K	0°		8°	0°		8°
L	0.45	0.60	0.75	0.018	0.024	0.030



Information furnished is believed to be accurate and reliable. However, STMicroelectronics assumes no responsibility for the consequences of use of such information nor for any infringement of patents or other rights of third parties which may result from its use. No license is granted by implication or otherwise under any patent or patent rights of STMicroelectronics. Specifications mentioned in this publication are subject to change without notice. This publication supersedes and replaces all information previously supplied. STMicroelectronics products are not authorized for use as critical components in life support devices or systems without express written approval of STMicroelectronics.

© The ST logo is a registered trademark of STMicroelectronics

© 2001 STMicroelectronics - Printed in Italy - All Rights Reserved
STMicroelectronics GROUP OF COMPANIES

Australia - Brazil - China - Finland - France - Germany - Hong Kong - India - Italy - Japan - Malaysia - Malta - Morocco
Singapore - Spain - Sweden - Switzerland - United Kingdom

© <http://www.st.com>