

32 Mbit (2Mb x16) low-voltage UV EPROM and OTP EPROM**Feature summary**

- 3.3V \pm 10% supply voltage in Read operation
- Read access time
 - 100ns at V_{CC} = 3.0V to 3.6V
- Pin compatible with M27C322
- Word-wide configurable
- 32 Mbit Mask ROM replacement
- Low power consumption
 - Active Current 30mA at 5MHz
 - Stand-by Current 60 μ A
- Programming voltage: 12V \pm 0.25V
- Programming time: 50 μ s/word
- Electronic signature
 - Manufacturer Code: 0020h
 - Device Code: 0034h
- ECOPACK® packages available

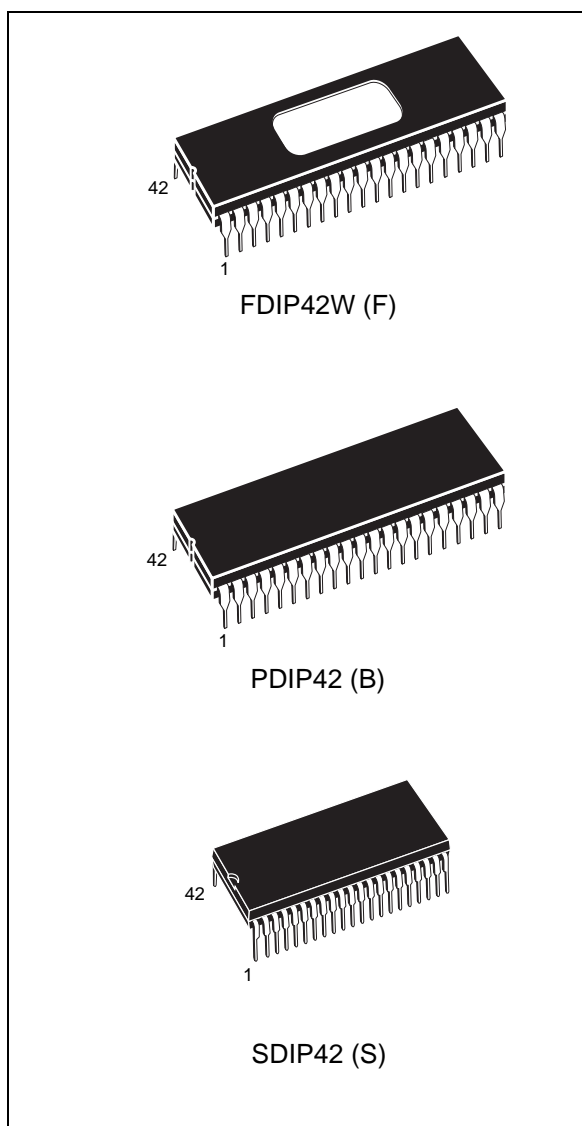

Contents

1	Summary description	5
2	Device operation	7
2.1	Read mode	7
2.2	Standby mode	7
2.3	Two Line Output Control	7
2.4	System considerations	8
2.5	Programming	8
2.6	PRESTO III programming algorithm	8
2.7	Program Inhibit	9
2.8	Program Verify	9
2.9	On-Board programming	9
2.10	Electronic Signature	10
2.11	Erase operation (applies to UV EPROM)	10
3	Maximum rating	11
4	DC and AC parameters	12
5	Package mechanical	18
6	Part numbering	21
7	Revision history	22

List of tables

Table 1.	Signal names	5
Table 2.	Operating modes	10
Table 3.	Electronic signature	10
Table 4.	Absolute maximum ratings	11
Table 5.	AC measurement conditions.	12
Table 6.	Capacitance	13
Table 7.	Read mode DC characteristics	14
Table 8.	Programming mode DC characteristics	14
Table 9.	Read mode AC characteristics	15
Table 10.	Margin mode AC characteristics	16
Table 11.	Programming mode AC characteristics	17
Table 12.	FDIP42W - 42 pin Ceramic Frit-seal DIP, with window (0.315" × 0.630"), mechanical data	18
Table 13.	PDIP42 - 42 pin Plastic DIP, 600 mils width, package mechanical data	19
Table 14.	SDIP42 - 42 lead Shrink Plastic DIP, 600 mils width, package mechanical data	20
Table 15.	Ordering information scheme	21
Table 16.	Document revision history	22

List of figures

Figure 1.	Logic diagram	5
Figure 2.	DIP connections	6
Figure 3.	Programming flowchart	9
Figure 4.	AC testing input output waveform	12
Figure 5.	AC testing load circuit	13
Figure 6.	Read mode AC waveforms	15
Figure 7.	Margin mode AC waveforms	16
Figure 8.	Programming and Verify modes AC waveforms	17
Figure 9.	FDIP42W - 42 pin Ceramic Frit-seal DIP, with window (0.315" × 0.630"), package outline	18
Figure 10.	PDIP42 - 42 pin Plastic DIP, 600 mils width, package outline	19
Figure 11.	SDIP42 - 42 pin Shrink Plastic DIP, 600 mils width, package outline	20

1 Summary description

The M27V322 is a 32 Mbit EPROM offered in the UV range (ultra violet erase) and OTP range. It is ideally suited for microprocessor systems requiring large data or program storage. It is organised as 2 MWords of 16 bit. The pin-out is compatible with a 32 Mbit Mask ROM.

The FDIP42W (window ceramic frit-seal package) has a transparent lid which allows the user to expose the chip to ultraviolet light to erase the bit pattern. A new pattern can then be written rapidly to the device by following the programming procedure.

For applications where the content is programmed only one time and erasure is not required, the M27V322 is offered in PDIP42 and SDIP42 packages.

In order to meet environmental requirements, ST offers the M27V322 in ECOPACK® packages.

ECOPACK packages are Lead-free. The category of second Level Interconnect is marked on the package and on the inner box label, in compliance with JEDEC Standard JESD97. The maximum ratings related to soldering conditions are also marked on the inner box label.

ECOPACK is an ST trademark. ECOPACK specifications are available at: www.st.com.

Figure 1. Logic diagram

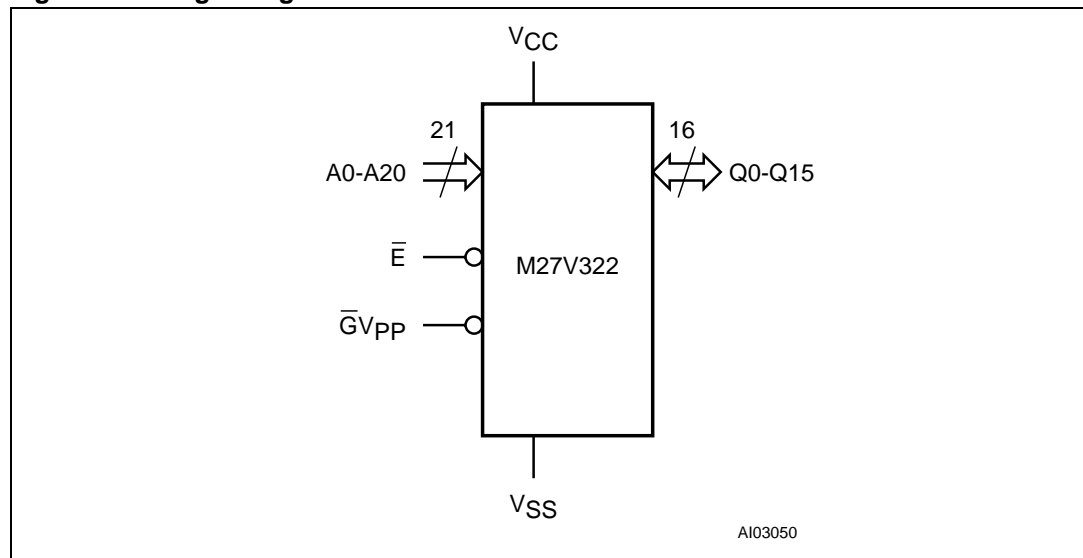
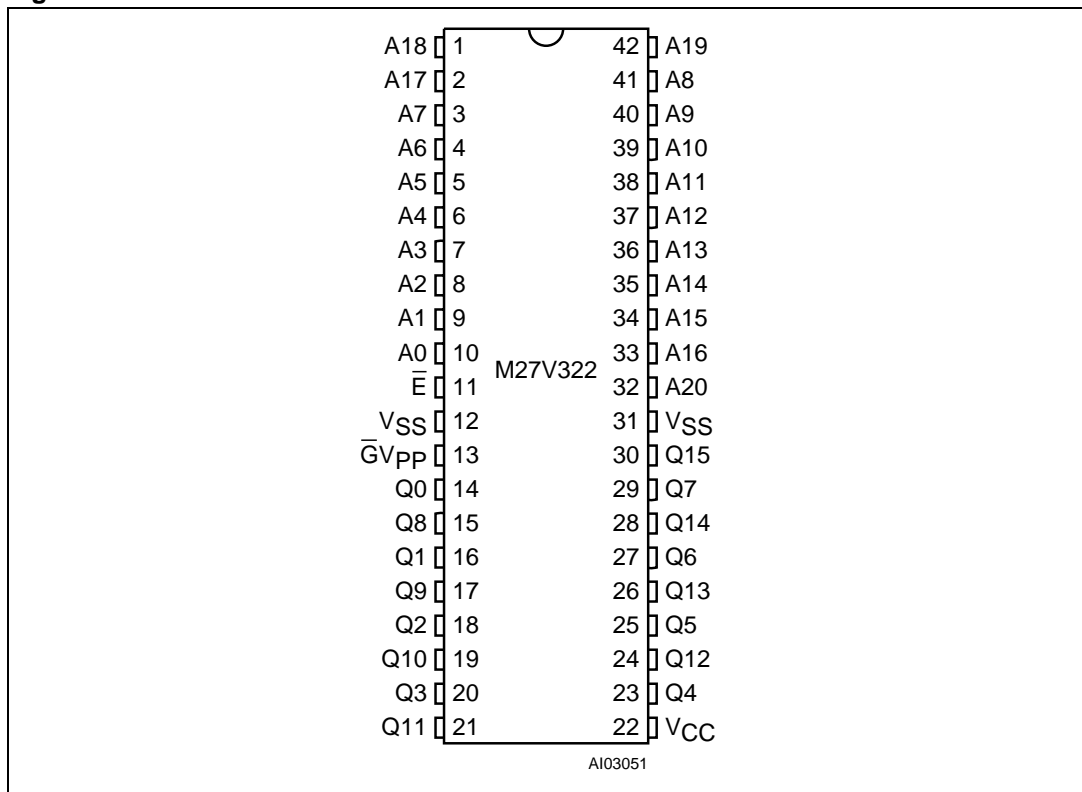

Table 1. Signal names

A0-A20	Address Inputs
Q0-Q15	Data Outputs
\bar{E}	Chip Enable
$\bar{G}V_{PP}$	Output Enable / Program Supply
V_{CC}	Supply Voltage
V_{SS}	Ground

Figure 2. DIP connections



2 Device operation

The operating modes of the M27V322 are listed in the Operating Modes Table. A single power supply is required in the read mode. All inputs are TTL compatible except for V_{PP} and 12V on A9 for the Electronic Signature.

2.1 Read mode

The M27V322 has a word-wide organization. Chip Enable (\bar{E}) is the power control and should be used for device selection. Output Enable (\bar{G}) is the output control and should be used to gate data to the output pins independent of device selection. Assuming that the addresses are stable, the address access time (t_{AVQV}) is equal to the delay from \bar{E} to output (t_{ELQV}). Data is available at the output after a delay of t_{GLQV} from the falling edge of $\bar{G}_{V_{PP}}$ assuming that \bar{E} has been low and the addresses have been stable for at least $t_{AVQV} - t_{GLQV}$.

2.2 Standby mode

The M27V322 has a standby mode which reduces the supply current from 30mA to 30 μ A. The M27V322 is placed in the standby mode by applying a CMOS high signal to the \bar{E} input. When in the standby mode, the outputs are in a high impedance state, independent of the $\bar{G}_{V_{PP}}$ input.

2.3 Two Line Output Control

Because EPROMs are usually used in larger memory arrays, this product features a 2 line control function which accommodates the use of multiple memory connection. The two line control function allows:

- the lowest possible memory power dissipation,
- complete assurance that output bus contention will not occur.

For the most efficient use of these two control lines, \bar{E} should be decoded and used as the primary device selecting function, while $\bar{G}_{V_{PP}}$ should be made a common connection to all devices in the array and connected to the \bar{READ} line from the system control bus. This ensures that all deselected memory devices are in their low power standby mode and that the output pins are only active when data is required from a particular memory device.

2.4 System considerations

The power switching characteristics of Advanced CMOS EPROMs require careful decoupling of the supplies to the devices. The supply current ICC has three segments of importance to the system designer: the standby current, the active current and the transient peaks that are produced by the falling and rising edges of \bar{E} . The magnitude of the transient current peaks is dependent on the capacitive and inductive loading of the device outputs. The associated transient voltage peaks can be suppressed by complying with the two line output control and by properly selected decoupling capacitors. It is recommended that a 0.1 μ F ceramic capacitor is used on every device between V_{CC} and V_{SS} . This should be a high frequency type of low inherent inductance and should be placed as close as possible to the device. In addition, a 4.7 μ F electrolytic capacitor should be used between V_{CC} and V_{SS} for every eight devices. This capacitor should be mounted near the power supply connection point. The purpose of this capacitor is to overcome the voltage drop caused by the inductive effects of PCB traces.

2.5 Programming

When delivered (and after each erasure for UV EPROM), all bits of the M27V322 are in the "1" state. Data is introduced by selectively programming "0"s into the desired bit locations. Although only "0"s will be programmed, both "1"s and "0"s can be present in the data word. The only way to change a "0" to a "1" is by die exposition to ultraviolet light (UV EPROM). The M27V322 is in the programming mode when V_{PP} input is at 12.V, \overline{GV}_{PP} is at V_{IH} and \bar{E} is pulsed to V_{IL} . The data to be programmed is applied to 16 bits in parallel to the data output pins. The levels required for the address and data inputs are TTL. V_{CC} is specified to be 6.25V \pm 0.25V.

2.6 PRESTO III programming algorithm

The PRESTO III Programming Algorithm allows the whole array to be programmed with a guaranteed margin in a typical time of 100 seconds. Programming with PRESTO III consists of applying a sequence of 50 μ s program pulses to each word until a correct verify occurs (see [Figure 3](#)). During programming and verify operation a MARGIN MODE circuit must be activated to guarantee that each cell is programmed with enough margin. No overprogram pulse is applied since the verify in MARGIN MODE provides the necessary margin to each programmed cell.

Figure 3. Programming flowchart

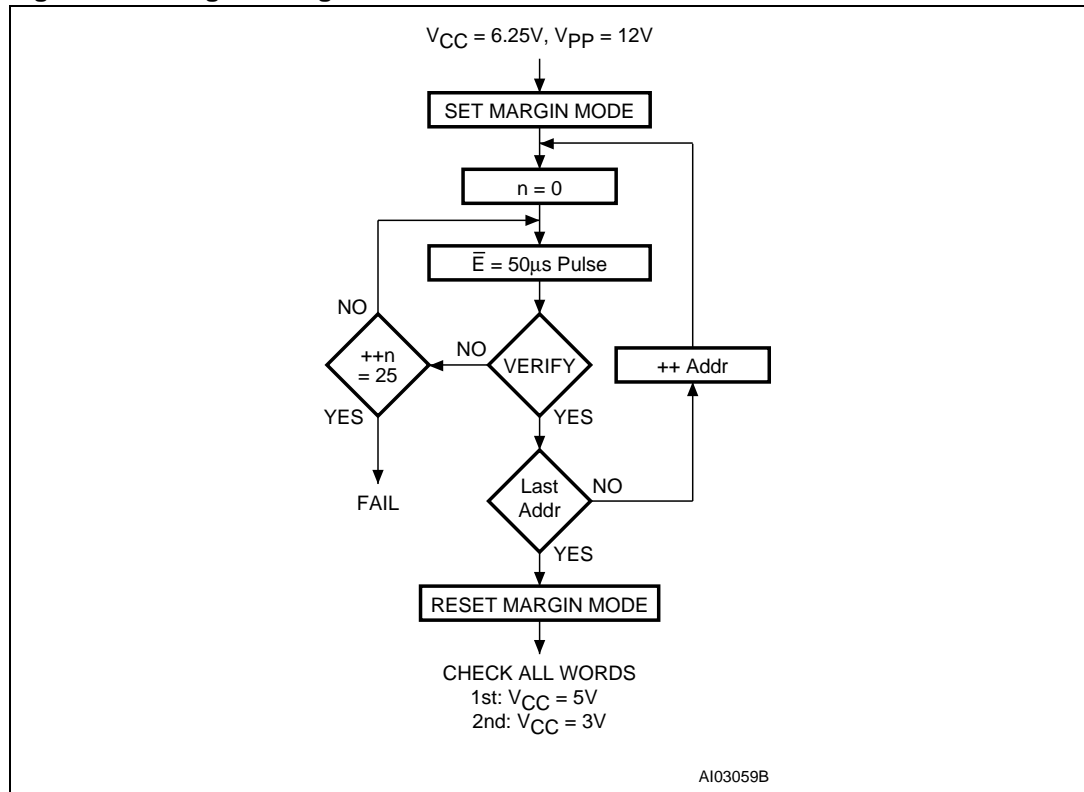

2.7 Program Inhibit

Programming of multiple M27V322s in parallel with different data is also easily accomplished. Except for \bar{E} , all like inputs including $\bar{G}V_{PP}$ of the parallel M27V322 may be common. A TTL low level pulse applied to a M27V322's \bar{E} input and V_{PP} at 12V, will program that M27V322. A high level \bar{E} input inhibits the other M27V322s from being programmed.

2.8 Program Verify

A verify (read) should be performed on the programmed bits to determine that they were correctly programmed. The verify is accomplished with $\bar{G}V_{PP}$ at V_{IL} . Data should be verified with t_{ELQV} after the falling edge of \bar{E} .

2.9 On-Board programming

The M27V322 can be directly programmed in the application circuit. See the relevant Application Note AN620.

2.10 Electronic Signature

The Electronic Signature (ES) mode allows the reading out of a binary code from an EPROM that will identify its manufacturer and type. This mode is intended for use by programming equipment to automatically match the device to be programmed with its corresponding programming algorithm. The ES mode is functional in the $25^{\circ}\text{C} \pm 5^{\circ}\text{C}$ ambient temperature range that is required when programming the M27V322. To activate the ES mode, the programming equipment must force 11.5V to 12.5V on address line A9 of the M27V322, with $V_{PP} = V_{CC} = 5\text{V}$. Two identifier bytes may then be sequenced from the device outputs by toggling address line A0 from V_{IL} to V_{IH} . All other address lines must be held at V_{IL} during Electronic Signature mode.

Byte 0 ($A0 = V_{IL}$) represents the manufacturer code and byte 1 ($A0 = V_{IH}$) the device identifier code. For the STMicroelectronics M27V322, these two identifier bytes are given in [Table 3](#) and can be read-out on outputs Q0 to Q7.

2.11 Erasure operation (applies to UV EPROM)

The erasure characteristics of the M27V322 is such that erasure begins when the cells are exposed to light with wavelengths shorter than approximately 4000 Å. It should be noted that sunlight and some type of fluorescent lamps have wavelengths in the 3000-4000 Å range. Research shows that constant exposure to room level fluorescent lighting could erase a typical M27V322 in about 3 years, while it would take approximately 1 week to cause erasure when exposed to direct sunlight. If the M27V322 is to be exposed to these types of lighting conditions for extended periods of time, it is suggested that opaque labels be put over the M27V322 window to prevent unintentional erasure. The recommended erasure procedure for M27V322 is exposure to short wave ultraviolet light which has a wavelength of 2537 Å. The integrated dose (i.e. UV intensity x exposure time) for erasure should be a minimum of 30 W-sec/cm². The erasure time with this dosage is approximately 30 to 40 minutes using an ultraviolet lamp with 12000 μW/cm² power rating. The M27V322 should be placed within 2.5cm (1 inch) of the lamp tubes during the erasure. Some lamps have a filter on their tubes which should be removed before erasure.

Table 2. Operating modes⁽¹⁾

Mode	\bar{E}	$\bar{G}V_{PP}$	A9	Q15-Q0
Read	V_{IL}	V_{IL}	X	Data Out
Output Disable	V_{IL}	V_{IH}	X	Hi-Z
Program	V_{IL} Pulse	V_{PP}	X	Data In
Program Inhibit	V_{IH}	V_{PP}	X	Hi-Z
Standby	V_{IH}	X	X	Hi-Z
Electronic Signature	V_{IL}	V_{IL}	V_{ID}	Codes

1. X = V_{IH} or V_{IL} , $V_{ID} = 12\text{V} \pm 0.5\text{V}$.

Table 3. Electronic signature⁽¹⁾

Identifier	A0	Q7	Q6	Q5	Q4	Q3	Q2	Q1	Q0	Hex Data
Manufacturer's Code	V_{IL}	0	0	1	0	0	0	0	0	20h
Device Code	V_{IH}	0	0	1	1	0	1	0	0	34h

1. Outputs Q15-Q8 are set to '0'.

3 Maximum rating

Stressing the device above the rating listed in the Absolute Maximum Ratings table may cause permanent damage to the device. These are stress ratings only and operation of the device at these or any other conditions above those indicated in the Operating sections of this specification is not implied. Exposure to Absolute Maximum Rating conditions for extended periods may affect device reliability. Refer also to the STMicroelectronics SURE Program and other relevant quality documents.

Table 4. Absolute maximum ratings

Symbol	Parameter	Value	Unit
T_A	Ambient Operating Temperature ⁽¹⁾	-40 to 125	°C
T_{BIAS}	Temperature Under Bias	-50 to 125	°C
T_{STG}	Storage Temperature	-65 to 150	°C
$V_{IO}^{(2)}$	Input or Output Voltage (except A9)	-2 to 7	V
V_{CC}	Supply Voltage	-2 to 7	V
$V_{A9}^{(2)}$	A9 Voltage	-2 to 13.5	V
V_{PP}	Program Supply Voltage	-2 to 14	V

1. Depends on range.
2. Minimum DC voltage on Input or Output is -0.5V with possible undershoot to -2.0V for a period less than 20ns. Maximum DC voltage on Output is $V_{CC} + 0.5V$ with possible overshoot to $V_{CC} + 2V$ for a period less than 20ns.

4 DC and AC parameters

This section summarizes the operating and measurement conditions, and the DC and AC characteristics of the device. The parameters in the DC and AC Characteristic tables that follow are derived from tests performed under the Measurement Conditions summarized in the relevant tables. Designers should check that the operating conditions in their circuit match the measurement conditions when relying on the quoted parameters.

Table 5. AC measurement conditions

	High Speed	Standard
Input Rise and Fall Times	$\leq 10\text{ns}$	$\leq 20\text{ns}$
Input Pulse Voltages	0 to 3V	0.4V to 2.4V
Input and Output Timing Ref. Voltages	1.5V	0.8V and 2V

Figure 4. AC testing input output waveform

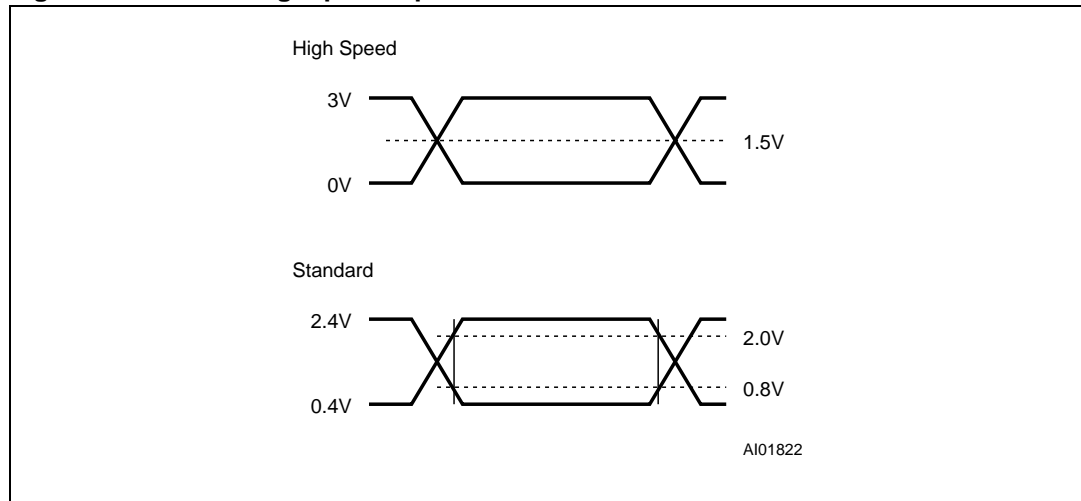
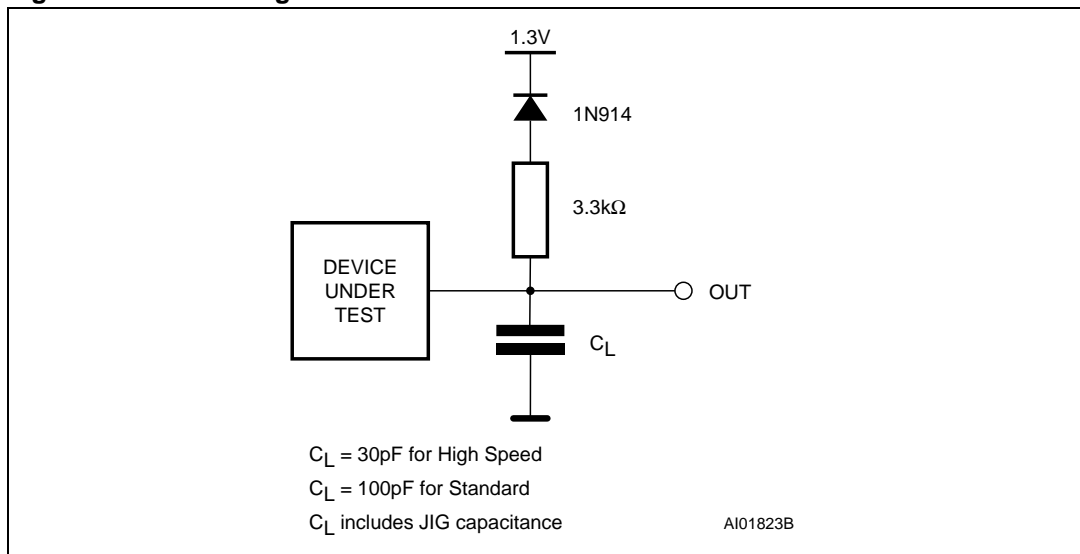

Figure 5. AC testing load circuit

Table 6. Capacitance^{(1) (2)}

Symbol	Parameter	Test Condition	Min	Max	Unit
C_{IN}	Input Capacitance	$V_{IN} = 0V$		10	pF
C_{OUT}	Output Capacitance	$V_{OUT} = 0V$		12	pF

1. $T_A = 25\text{ }^\circ\text{C}$, $f = 1\text{ MHz}$

2. Sampled only, not 100% tested.

Table 7. Read mode DC characteristics^{(1) (2)}

Symbol	Parameter	Test Condition	Min	Max	Unit
I_{LI}	Input Leakage Current	$0V \leq V_{IN} \leq V_{CC}$		± 1	μA
I_{LO}	Output Leakage Current	$0V \leq V_{OUT} \leq V_{CC}$		± 10	μA
I_{CC}	Supply Current	$\bar{E} = V_{IL}, \bar{O}V_{PP} = V_{IL}, I_{OUT} = 0mA, f = 5MHz$		30	mA
I_{CC1}	Supply Current (Standby) TTL	$\bar{E} = V_{IH}$		1	mA
I_{CC2}	Supply Current (Standby) CMOS	$\bar{E} > V_{CC} - 0.2V$		60	μA
I_{PP}	Program Current	$V_{PP} = V_{CC}$		10	μA
V_{IL}	Input Low Voltage		-0.6	$0.2V_{CC}$	V
$V_{IH}^{(3)}$	Input High Voltage		$0.7V_{CC}$	$V_{CC} + 0.5$	V
V_{OL}	Output Low Voltage	$I_{OL} = 2.1mA$		0.4	V
V_{OH}	Output High Voltage TTL	$I_{OH} = -400\mu A$	2.4		V

- $T_A = -40$ to 85 °C or 0 to 70 °C; $V_{CC} = 3.3V \pm 10\%$; $V_{PP} = V_{CC}$
- V_{CC} must be applied simultaneously with or before V_{PP} and removed simultaneously or after V_{PP} .
- Maximum DC voltage on Output is $V_{CC} + 0.5V$.

Table 8. Programming mode DC characteristics^{(1) (2)}

Symbol	Parameter	Test Condition	Min	Max	Unit
I_{LI}	Input Leakage Current	$V_{IL} \leq V_{IN} \leq V_{IH}$		± 10	μA
I_{CC}	Supply Current			50	mA
I_{PP}	Program Current	$\bar{E} = V_{IL}$		50	mA
V_{IL}	Input Low Voltage		-0.3	0.8	V
V_{IH}	Input High Voltage		2.4	$V_{CC} + 0.5$	V
V_{OL}	Output Low Voltage	$I_{OL} = 2.1mA$		0.4	V
V_{OH}	Output High Voltage TTL	$I_{OH} = -2.5mA$	3.5		V
V_{ID}	A9 Voltage		11.5	12.5	V

- $T_A = 25$ °C; $V_{CC} = 6.25V \pm 0.25V$; $V_{PP} = 12V \pm 0.25V$
- V_{CC} must be applied simultaneously with or before V_{PP} and removed simultaneously or after V_{PP} .

Figure 6. Read mode AC waveforms

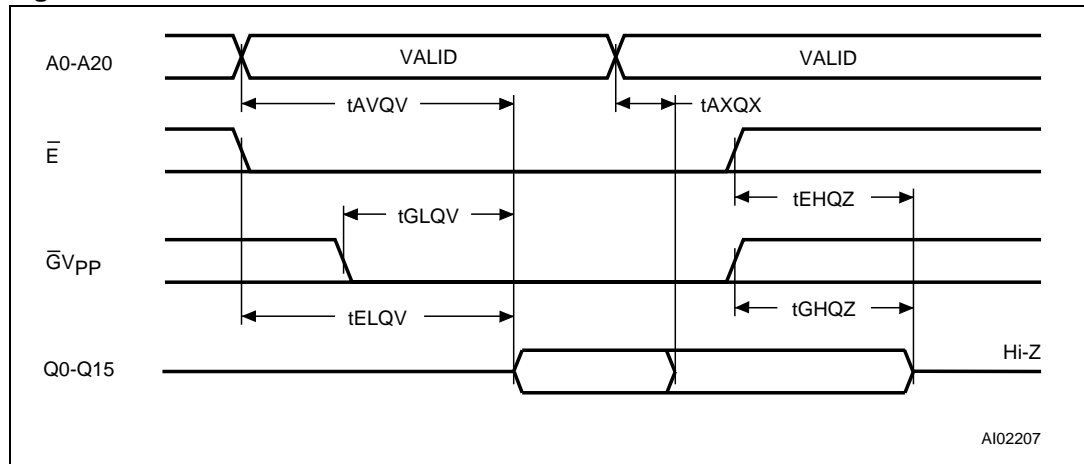
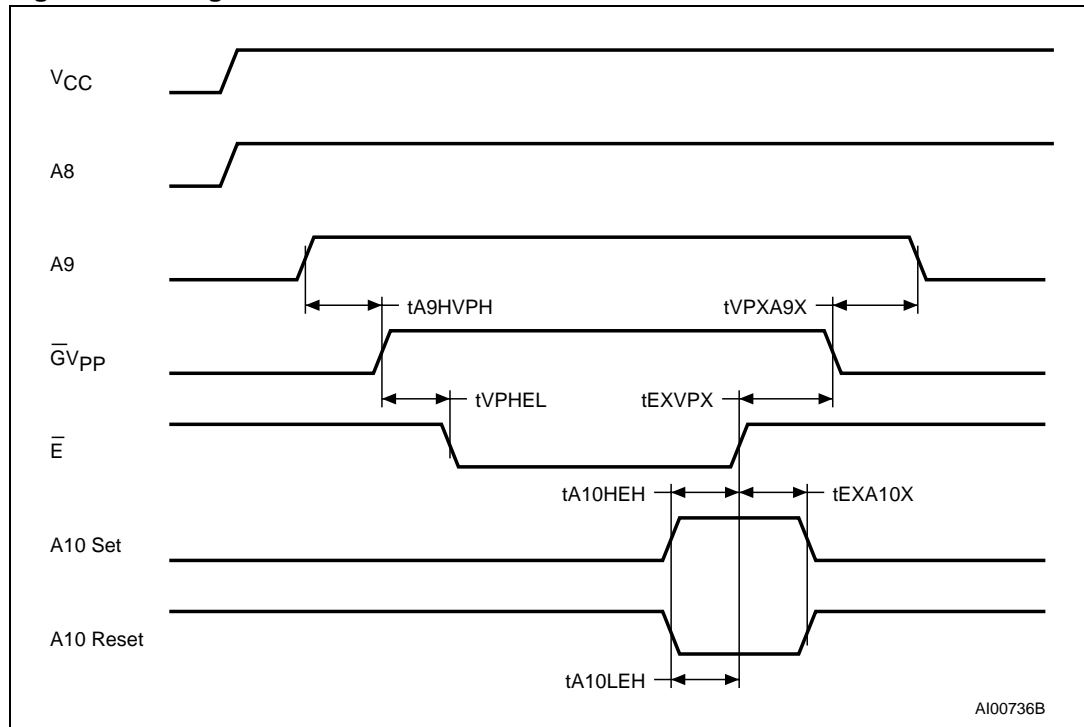

Table 9. Read mode AC characteristics^{(1) (2)}

Symbol	Alt	Parameter	Test Condition	M27V322						Unit
				-100 ⁽³⁾		-120		-150		
				Min	Max	Min	Max	Min	Max	
t_{AVQV}	t_{ACC}	Address Valid to Output Valid	$\bar{E} = V_{IL}$, $\bar{G} = V_{IL}$		100		120		150	ns
t_{ELQV}	t_{CE}	Chip Enable Low to Output Valid	$\bar{G} = V_{IL}$		100		120		150	ns
t_{GLQV}	t_{OE}	Output Enable Low to Output Valid	$\bar{E} = V_{IL}$		50		60		60	ns
$t_{EHQZ}^{(4)}$	t_{DF}	Chip Enable High to Output Hi-Z	$\bar{G} = V_{IL}$	0	45	0	50	0	50	ns
$t_{GHQZ}^{(4)}$	t_{DF}	Output Enable High to Output Hi-Z	$\bar{E} = V_{IL}$	0	45	0	50	0	50	ns
t_{AXQX}	t_{OH}	Address Transition to Output Transition	$\bar{E} = V_{IL}$, $\bar{G} = V_{IL}$	5		5		5		ns

1. $T_A = -40$ to 85 °C or 0 to 70 °C; $V_{CC} = 3.3V \pm 10\%$; $V_{PP} = V_{CC}$
2. V_{CC} must be applied simultaneously with or before V_{PP} and removed simultaneously or after V_{PP}
3. Speed obtained with High Speed measurement conditions.
4. Sampled only, not 100% tested.

Figure 7. Margin mode AC waveforms



1. A8 High level = 5V; A9 High level = 12V.

Table 10. Margin mode AC characteristics^{(1) (2)}

Symbol	Alt	Parameter	Test Condition	Min	Max	Unit
t _{A9HVP}	t _{AS9}	V _{A9} High to V _{PP} High		2		μs
t _{VPHE}	t _{VPS}	V _{PP} High to Chip Enable Low		2		μs
t _{A10HE}	t _{AS10}	V _{A10} High to Chip Enable High (Set)		1		μs
t _{A10LE}	t _{AS10}	V _{A10} Low to Chip Enable High (Reset)		1		μs
t _{EXA10}	t _{AH10}	Chip Enable Transition to V _{A10} Transition		1		μs
t _{EXVP}	t _{VPH}	Chip Enable Transition to V _{PP} Transition		2		μs
t _{VPXA9}	t _{AH9}	V _{PP} Transition to V _{A9} Transition		2		μs

1. T_A = 25 °C; V_{CC} = 6.25V ± 0.25V; V_{PP} = 12V ± 0.25V

2. V_{CC} must be applied simultaneously with or before V_{PP} and removed simultaneously or after V_{PP}.

Figure 8. Programming and Verify modes AC waveforms

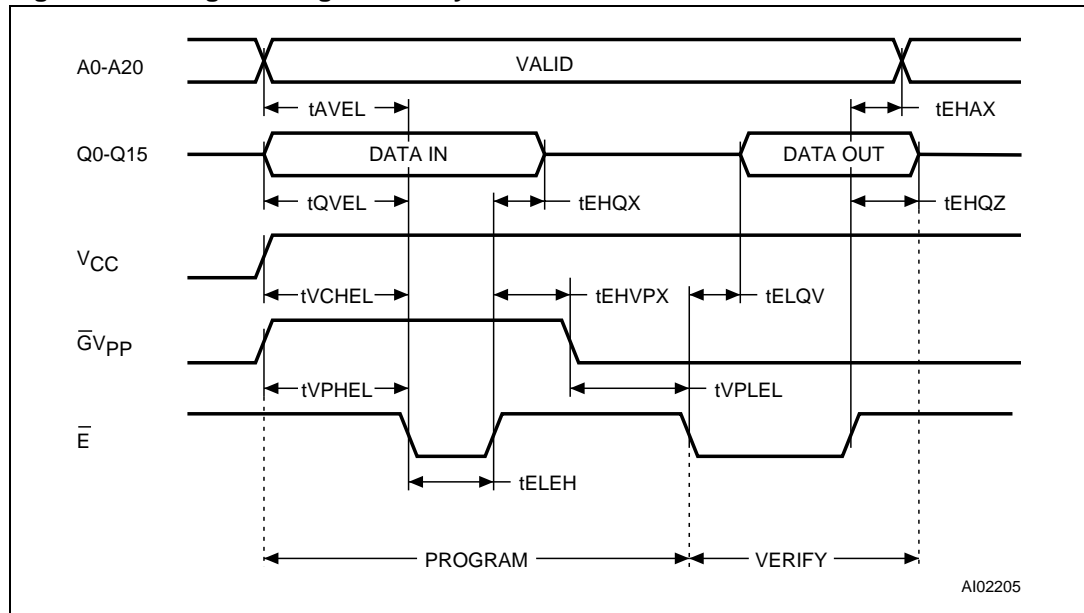

1. $\overline{\text{BYTE}} = V_{IH}$.

Table 11. Programming mode AC characteristics^{(1) (2)}

Symbol	Alt	Parameter	Test Condition	Min	Max	Unit
t _{AVEL}	t _{AS}	Address Valid to Chip Enable Low		1		μs
t _{QVEL}	t _{DS}	Input Valid to Chip Enable Low		1		μs
t _{VCHL}	t _{VCS}	V _{CC} High to Chip Enable Low		2		μs
t _{VPHEL}	t _{OES}	V _{PP} High to Chip Enable Low		1		μs
t _{VLVPH}	t _{PRT}	V _{PP} Rise Time		50		ns
t _{ELEH}	t _{PW}	Chip Enable Program Pulse Width (Initial)		45	55	μs
t _{EHQX}	t _{DH}	Chip Enable High to Input Transition		2		μs
t _{EHVPX}	t _{OEH}	Chip Enable High to V _{PP} Transition		2		μs
t _{VPLEL}	t _{VR}	V _{PP} Low to Chip Enable Low		1		μs
t _{ELQV}	t _{DV}	Chip Enable Low to Output Valid			1	μs
t _{EHQZ} ⁽³⁾	t _{DFP}	Chip Enable High to Output Hi-Z		0	130	ns
t _{EHAX}	t _{AH}	Chip Enable High to Address Transition		0		ns

1. T_A = 25 °C; V_{CC} = 6.25V ± 0.25V; V_{PP} = 12V ± 0.25V

2. V_{CC} must be applied simultaneously with or before V_{PP} and removed simultaneously or after V_{PP}.

3. Sampled only, not 100% tested.

5 Package mechanical

Figure 9. FDIP42W - 42 pin Ceramic Frit-seal DIP, with window (0.315" x 0.630"), package outline

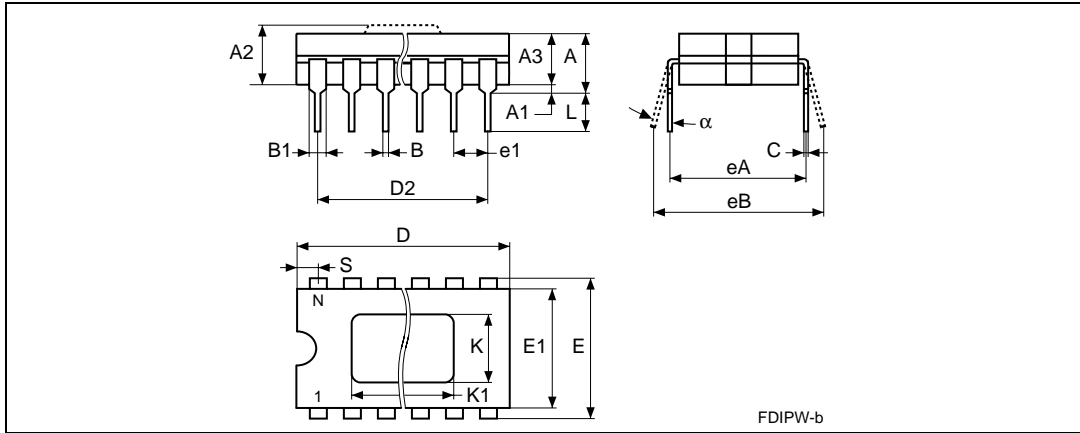

1. Drawing is not to scale.

Table 12. FDIP42W - 42 pin Ceramic Frit-seal DIP, with window (0.315" x 0.630"), mechanical data

Symbol	millimeters			inches			
	Typ	Min	Max	Typ	Min	Max	
A			5.72			0.225	
A1		0.51	1.40		0.020	0.055	
A2		3.91	4.57		0.154	0.180	
A3		3.89	4.50		0.153	0.177	
B		0.41	0.56		0.016	0.022	
B1	1.45	–	–	0.057	–	–	
C		0.23	0.30		0.009	0.012	
D		54.41	54.86		2.142	2.160	
D2	50.80	–	–	2.000	–	–	
E	15.24	–	–	0.600	–	–	
E1		14.50	14.90		0.571	0.587	
e	2.54	–	–	0.100	–	–	
eA	14.99	–	–	0.590	–	–	
eB		16.18	18.03		0.637	0.710	
L		3.18	4.10		0.125	0.161	
S		1.52	2.49		0.060	0.098	
K	8.00	–	–	0.315	–	–	
K1	16.00	–	–	0.630	–	–	
α		4°	11°		4°	11°	
N		42				42	

Figure 10. PDIP42 - 42 pin Plastic DIP, 600 mils width, package outline

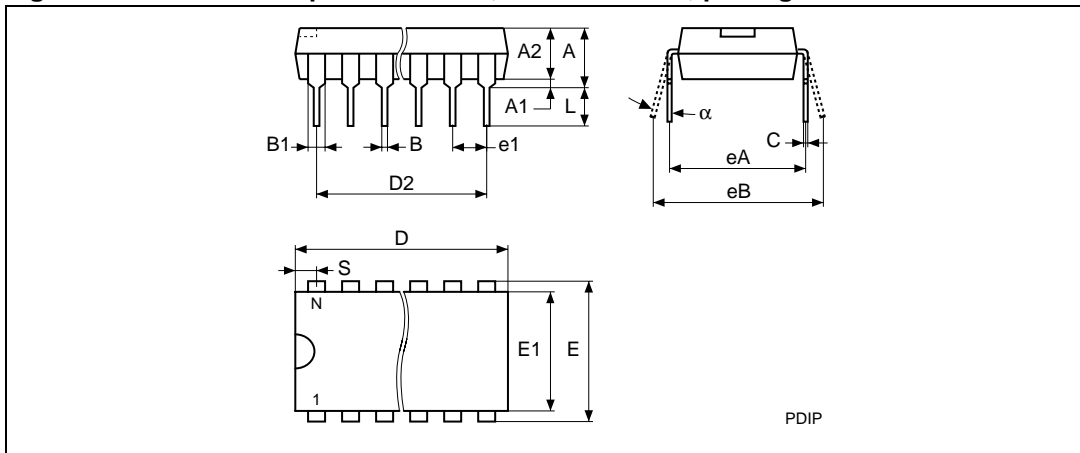

1. Drawing is not to scale.

Table 13. PDIP42 - 42 pin Plastic DIP, 600 mils width, package mechanical data

Symbol	millimeters			inches		
	Typ	Min	Max	Typ	Min	Max
A		–	5.08		–	0.200
A1		0.25	–		0.010	–
A2		3.56	4.06		0.140	0.160
B		0.38	0.53		0.015	0.021
B1		1.27	1.65		0.050	0.065
C		0.20	0.36		0.008	0.014
D		52.20	52.71		2.055	2.075
D2	50.80	–	–	2.000	–	–
E	15.24	–	–	0.600	–	–
E1		13.59	13.84		0.535	0.545
e1	2.54	–	–	0.100	–	–
eA	14.99	–	–	0.590	–	–
eB		15.24	17.78		0.600	0.700
L		3.18	3.43		0.125	0.135
S		0.86	1.37		0.034	0.054
α		0°	10°		0°	10°
N		42			42	

Figure 11. SDIP42 - 42 pin Shrink Plastic DIP, 600 mils width, package outline

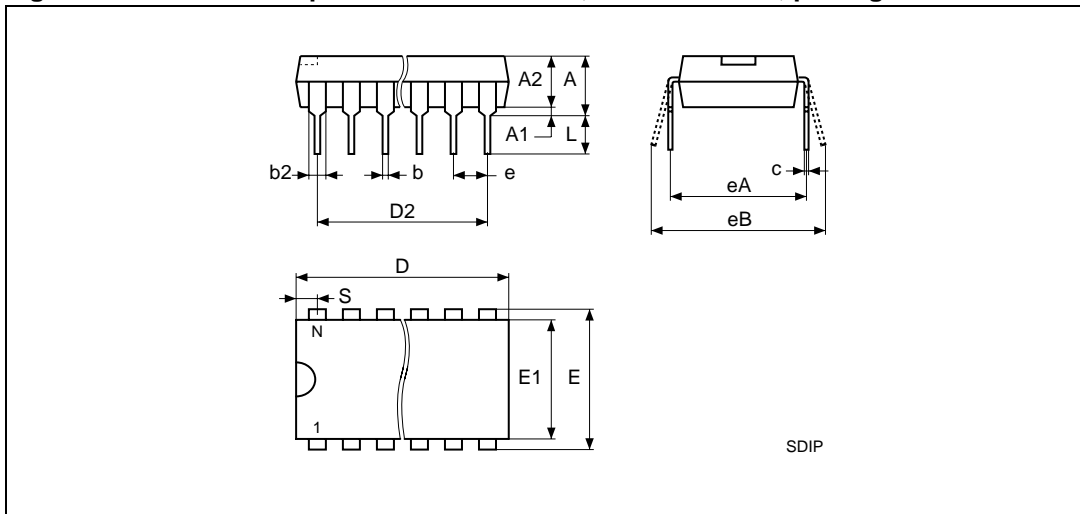

1. Drawing is not to scale.

Table 14. SDIP42 - 42 lead Shrink Plastic DIP, 600 mils width, package mechanical data

Symbol	millimeters			inches		
	Typ	Min	Max	Typ	Min	Max
A			5.08			0.200
A1		0.51			0.020	
A2	3.81	3.05	4.57	0.150	0.120	0.180
b	0.46	0.38	0.56	0.018	0.015	0.022
b2	1.02	0.89	1.14	0.040	0.035	0.045
c	0.25	0.23	0.38	0.010	0.009	0.015
D	36.83	36.58	37.08	1.450	1.440	1.460
D2	35.60	–	–	1.402	–	–
e	1.78	–	–	0.070	–	–
E		15.24	16.00		0.600	0.630
E1	13.72	12.70	14.48	0.540	0.500	0.570
eA	15.24			0.600		
eB			18.54			0.730
L	3.30	2.54	3.56	0.130	0.100	0.140
S	0.64			0.025		
N	42			42		

6 Part numbering

Table 15. Ordering information scheme

Example:	M27V322	-100	X	F	1
Device Type					
M27					
Supply Voltage					
V = 3.3V ±10%					
Device Function					
322 = 32 Mbit (2Mb x16)					
Speed					
-100 = 100 ns ⁽¹⁾					
-120 = 120 ns					
-150 = 150 ns					
V_{CC} Tolerance					
blank = 3.3V ±10%					
X = 3.3V ±5%					
Package					
F = FDIP42W					
B = PDIP42					
S = SDIP42					
Temperature Range					
1 = 0 to 70 °C					
6 = -40 to 85 °C					

1. High Speed, see AC Characteristics section for further information.

For a list of available options (Speed, Package, etc.) or for further information on any aspect of this device, please contact the STMicroelectronics Sales Office nearest to you.

7 Revision history

Table 16. Document revision history

Date	Revision	Revision Details
July 1999	0.1	First Issue
02/09/00	1	Programming Flowchart changed (Figure 3) PRESTO III Programming Algorithm paragraph changed FDIP42W Package Dimension, L Max added (Table 12)
03/01/01	2	SDIP42 Package added (Figure 11 , Table 14)
22-May-2006	3	Document converted to new template (sections added, information moved). Packages are ECOPACK® compliant. SDIP42 package specifications updated (see Table 14 and Figure 11).

Please Read Carefully:

Information in this document is provided solely in connection with ST products. STMicroelectronics NV and its subsidiaries ("ST") reserve the right to make changes, corrections, modifications or improvements, to this document, and the products and services described herein at any time, without notice.

All ST products are sold pursuant to ST's terms and conditions of sale.

Purchasers are solely responsible for the choice, selection and use of the ST products and services described herein, and ST assumes no liability whatsoever relating to the choice, selection or use of the ST products and services described herein.

No license, express or implied, by estoppel or otherwise, to any intellectual property rights is granted under this document. If any part of this document refers to any third party products or services it shall not be deemed a license grant by ST for the use of such third party products or services, or any intellectual property contained therein or considered as a warranty covering the use in any manner whatsoever of such third party products or services or any intellectual property contained therein.

UNLESS OTHERWISE SET FORTH IN ST'S TERMS AND CONDITIONS OF SALE ST DISCLAIMS ANY EXPRESS OR IMPLIED WARRANTY WITH RESPECT TO THE USE AND/OR SALE OF ST PRODUCTS INCLUDING WITHOUT LIMITATION IMPLIED WARRANTIES OF MERCHANTABILITY, FITNESS FOR A PARTICULAR PURPOSE (AND THEIR EQUIVALENTS UNDER THE LAWS OF ANY JURISDICTION), OR INFRINGEMENT OF ANY PATENT, COPYRIGHT OR OTHER INTELLECTUAL PROPERTY RIGHT.

UNLESS EXPRESSLY APPROVED IN WRITING BY AN AUTHORIZED REPRESENTATIVE OF ST, ST PRODUCTS ARE NOT DESIGNED, AUTHORIZED OR WARRANTED FOR USE IN MILITARY, AIR CRAFT, SPACE, LIFE SAVING, OR LIFE SUSTAINING APPLICATIONS, NOR IN PRODUCTS OR SYSTEMS, WHERE FAILURE OR MALFUNCTION MAY RESULT IN PERSONAL INJURY, DEATH, OR SEVERE PROPERTY OR ENVIRONMENTAL DAMAGE.

Resale of ST products with provisions different from the statements and/or technical features set forth in this document shall immediately void any warranty granted by ST for the ST product or service described herein and shall not create or extend in any manner whatsoever, any liability of ST.

ST and the ST logo are trademarks or registered trademarks of ST in various countries.

Information in this document supersedes and replaces all information previously supplied.

The ST logo is a registered trademark of STMicroelectronics. All other names are the property of their respective owners.

© 2006 STMicroelectronics - All rights reserved

STMicroelectronics group of companies

Australia - Belgium - Brazil - Canada - China - Czech Republic - Finland - France - Germany - Hong Kong - India - Israel - Italy - Japan - Malaysia - Malta - Morocco - Singapore - Spain - Sweden - Switzerland - United Kingdom - United States of America

www.st.com

