

FEATURES

- 2-Channel Simultaneous Sampling ADC
- Serial LVDS Outputs: 1, 2 or 4 Bits per Channel
- 84.1dB SNR (46 μ V_{RMS} Input Referred Noise)
- 99dB SFDR
- Low Power: 185mW Total
- 92mW per Channel
- Single 1.8V Supply
- Selectable Input Ranges: 1V_{P-P} to 2.1V_{P-P}
- 200MHz Full-Power Bandwidth S/H
- Shutdown and Nap Modes
- Serial SPI Port for Configuration
- Pin Compatible With
 - LTC2190: 16-Bit, 25Msps, 104mW
- 52-Lead (7mm × 8mm) QFN Package

APPLICATIONS

- Low Power Instrumentation
- Software-Defined Radios
- Portable Medical Imaging
- Multi-Channel Data Acquisition

DESCRIPTION

The LTC[®]2271 is a 2-channel, simultaneous sampling 16-bit A/D converter designed for digitizing high frequency, wide dynamic range signals. It is perfect for demanding communications applications with AC performance that includes 84.1dB SNR and 99dB spurious free dynamic range (SFDR).

DC specs include ± 1 LSB INL (typ), ± 0.2 LSB DNL (typ) and no missing codes over temperature. The transition noise is 1.44LSB_{RMS}.

To minimize the number of data lines the digital outputs are serial LVDS. Each channel outputs one bit, two bits or four bits at a time. The LVDS drivers have optional internal termination and adjustable output levels to ensure clean signal integrity.

The ENC⁺ and ENC⁻ inputs may be driven differentially or single ended with a sine wave, PECL, LVDS, TTL or CMOS inputs. An internal clock duty cycle stabilizer allows high performance at full speed for a wide range of clock duty cycles.

LT, LT, LTC, LTM, Linear Technology and the Linear logo are registered trademarks of Linear Technology Corporation. All other trademarks are the property of their respective owners.

TYPICAL APPLICATION

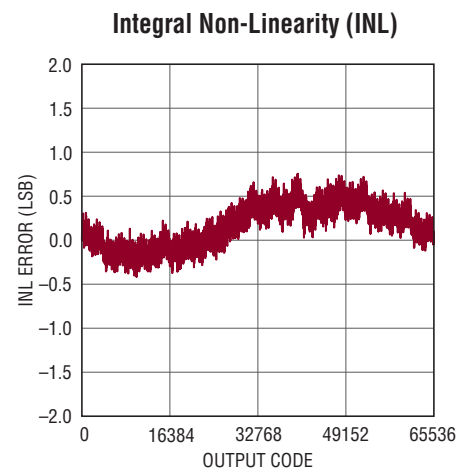
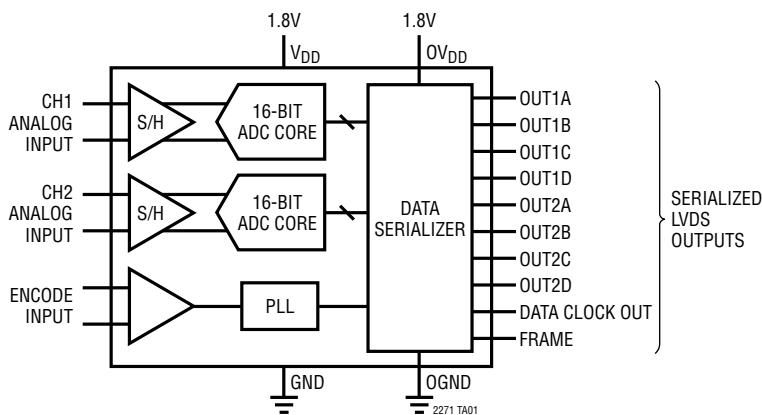

LTC2271

ABSOLUTE MAXIMUM RATINGS

(Notes 1, 2)

Supply Voltages

V_{DD} , OV_{DD} -0.3V to 2V

Analog Input Voltage

A_{IN+} , A_{IN-} , PAR/SER, SENSE
(Note 3) -0.3V to ($V_{DD} + 0.2V$)

Digital Input Voltage

ENC^+ , ENC^- , \overline{CS} , SDI, SCK (Note 4) -0.3V to 3.9V

SDO (Note 4) -0.3V to 3.9V

Digital Output Voltage -0.3V to ($OV_{DD} + 0.3V$)

Operating Temperature Range

LTC2271C 0°C to 70°C

LTC2271I -40°C to 85°C

Storage Temperature Range -65°C to 150°C

PIN CONFIGURATION

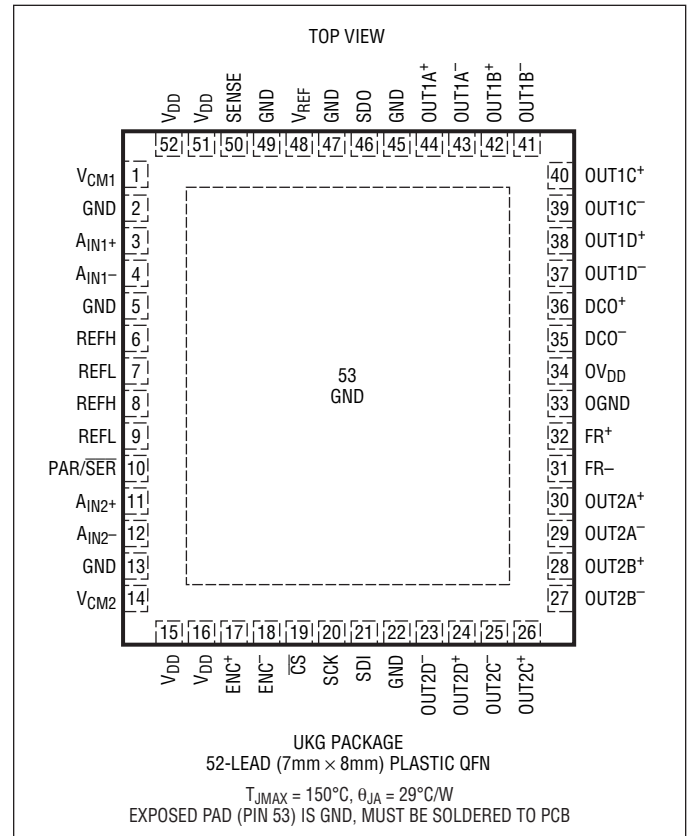

ORDER INFORMATION

LEAD FREE FINISH	TAPE AND REEL	PART MARKING*	PACKAGE DESCRIPTION	TEMPERATURE RANGE
LTC2271CUKG#PBF	LTC2271CUKG#TRPBF	LTC2271UKG	52-Lead (7mm × 8mm) Plastic QFN	0°C to 70°C
LTC2271IUKG#PBF	LTC2271IUKG#TRPBF	LTC2271UKG	52-Lead (7mm × 8mm) Plastic QFN	-40°C to 85°C

Consult LTC Marketing for parts specified with wider operating temperature ranges. *The temperature grade is identified by a label on the shipping container. Consult LTC Marketing for information on non-standard lead based finish parts.

For more information on lead free part marking, go to: <http://www.linear.com/leadfree/>

For more information on tape and reel specifications, go to: <http://www.linear.com/tapeandreeel/>

CONVERTER CHARACTERISTICS

The ● denotes the specifications which apply over the full operating temperature range, otherwise specifications are at $T_A = 25^\circ\text{C}$. (Note 5)

PARAMETER	CONDITIONS		MIN	TYP	MAX	UNITS
Resolution (No Missing Codes)		●	16			Bits
Integral Linearity Error	Differential Analog Input (Note 6)	●	-2.6	± 1	2.6	LSB
Differential Linearity Error	Differential Analog Input	●	-0.8	± 0.2	0.8	LSB
Offset Error	(Note 7)	●	-7	± 1.3	7	mV
Gain Error	Internal Reference External Reference	●	-1.6	± 1.2 -0.3	1	%FS %FS
Offset Drift				± 10		$\mu\text{V}/^\circ\text{C}$
Full-Scale Drift	Internal Reference External Reference			± 30 ± 10		ppm/ $^\circ\text{C}$ ppm/ $^\circ\text{C}$
Gain Matching		●	-0.2	± 0.06	0.2	%FS
Offset Matching		●	-10	± 1.5	10	mV
Transition Noise				1.44		LSB _{RMS}

ANALOG INPUT

The ● denotes the specifications which apply over the full operating temperature range, otherwise specifications are at $T_A = 25^\circ\text{C}$. (Note 5)

SYMBOL	PARAMETER	CONDITIONS		MIN	TYP	MAX	UNITS
V_{IN}	Analog Input Range ($A_{IN+} - A_{IN-}$)	$1.7\text{V} < V_{DD} < 1.9\text{V}$	●		1 to 2.1		V_{P-P}
$V_{IN(CM)}$	Analog Input Common Mode ($A_{IN+} + A_{IN-}$)/2	Differential Analog Input (Note 8)	●	0.65	V_{CM}	$V_{CM} + 200\text{mV}$	V
V_{SENSE}	External Voltage Reference Applied to SENSE	External Reference Mode	●	0.625	1.250	1.300	V
I_{INCM}	Analog Input Common Mode Current	Per Pin, 20Msps			32		μA
I_{IN1}	Analog Input Leakage Current (No Encode)	$0 < A_{IN+}, A_{IN-} < V_{DD}$	●	-1		1	μA
I_{IN2}	PAR/SER Input Leakage Current	$0 < \text{PAR}/\text{SER} < V_{DD}$	●	-1		1	μA
I_{IN3}	SENSE Input Leakage Current	$0.625\text{V} < \text{SENSE} < 1.3\text{V}$	●	-2		2	μA
t_{AP}	Sample-and-Hold Acquisition Delay Time				0		ns
t_{JITTER}	Sample-and-Hold Acquisition Delay Jitter	Single-Ended Encode Differential Encode			85 100		fS _{RMS} fS _{RMS}
CMRR	Analog Input Common Mode Rejection Ratio				80		dB
BW-3B	Full-Power Bandwidth	Figure 5 Test Circuit			200		MHz

DYNAMIC ACCURACY

The ● denotes the specifications which apply over the full operating temperature range, otherwise specifications are at $T_A = 25^\circ\text{C}$. $A_{IN} = -1\text{dBFS}$. (Note 5)

SYMBOL	PARAMETER	CONDITIONS	MIN	TYP	MAX	UNITS
SNR	Signal-to-Noise Ratio	1.4MHz Input	● 82.3	84.1		dBFS
		5MHz Input		84.1		dBFS
		30MHz Input		83.8		dBFS
		70MHz Input		82.7		dBFS
SFDR	Spurious Free Dynamic Range, 2nd Harmonic	1.4MHz Input	● 88	99		dBFS
		5MHz Input		98		dBFS
		30MHz Input		98		dBFS
		70MHz Input		90		dBFS
	Spurious Free Dynamic Range, 3rd Harmonic	1.4MHz Input	● 88	99		dBFS
		5MHz Input		98		dBFS
		30MHz Input		98		dBFS
		70MHz Input		96		dBFS
	Spurious Free Dynamic Range, 4th Harmonic or Higher	1.4MHz Input	● 93	110		dBFS
5MHz Input		110		dBFS		
30MHz Input		105		dBFS		
70MHz Input		100		dBFS		
S/(N+D)	Signal-to-Noise Plus Distortion Ratio	1.4MHz Input	● 81.8	83.9		dBFS
		5MHz Input		83.9		dBFS
		30MHz Input		83.7		dBFS
		70MHz Input		82.0		dBFS
		Crosstalk		10MHz Input		

INTERNAL REFERENCE CHARACTERISTICS

The ● denotes the specifications which apply over the full operating temperature range, otherwise specifications are at $T_A = 25^\circ\text{C}$. (Note 5)

PARAMETER	CONDITIONS	MIN	TYP	MAX	UNITS
V_{CM} Output Voltage	$I_{OUT} = 0$	● $0.5 \cdot V_{DD} - 25\text{mV}$	$0.5 \cdot V_{DD}$	$0.5 \cdot V_{DD} + 25\text{mV}$	V
V_{CM} Output Temperature Drift			± 25		ppm/ $^\circ\text{C}$
V_{CM} Output Resistance	$-600\mu\text{A} < I_{OUT} < 1\text{mA}$		4		Ω
V_{REF} Output Voltage	$I_{OUT} = 0$	● 1.230	1.250	1.270	V
V_{REF} Output Temperature Drift			± 25		ppm/ $^\circ\text{C}$
V_{REF} Output Resistance	$-400\mu\text{A} < I_{OUT} < 1\text{mA}$		7		Ω
V_{REF} Line Regulation	$1.7\text{V} < V_{DD} < 1.9\text{V}$		0.6		mV/V

DIGITAL INPUTS AND OUTPUTS

The ● denotes the specifications which apply over the full operating temperature range, otherwise specifications are at $T_A = 25^\circ\text{C}$. (Note 5)

SYMBOL	PARAMETER	CONDITIONS	MIN	TYP	MAX	UNITS
ENCODE INPUTS (ENC⁺, ENC⁻)						
Differential Encode Mode (ENC⁻ Not Tied to GND)						
V_{ID}	Differential Input Voltage	(Note 8)	● 0.2			V
V_{ICM}	Common Mode Input Voltage	Internally Set	● 1.1	1.2		V
		Externally Set (Note 8)			1.6	V
V_{IN}	Input Voltage Range	ENC ⁺ , ENC ⁻ to GND (Note 8)	● 0.2		3.6	V
R_{IN}	Input Resistance	See Figure 10		10		k Ω
C_{IN}	Input Capacitance	(Note 8)		3.5		pF

DIGITAL INPUTS AND OUTPUTS

The ● denotes the specifications which apply over the full operating temperature range, otherwise specifications are at $T_A = 25^\circ\text{C}$. (Note 5)

SYMBOL	PARAMETER	CONDITIONS	MIN	TYP	MAX	UNITS
Single-Ended Encode Mode (ENC⁻ Tied to GND)						
V _{IH}	High Level Input Voltage	V _{DD} = 1.8V	●	1.2		V
V _{IL}	Low Level Input Voltage	V _{DD} = 1.8V	●		0.6	V
V _{IN}	Input Voltage Range	ENC ⁺ to GND	●	0	3.6	V
R _{IN}	Input Resistance	See Figure 11		30		kΩ
C _{IN}	Input Capacitance	(Note 8)		3.5		pF
DIGITAL INPUTS (CS⁻, SDI, SCK in Serial or Parallel Programming Mode. SDO in Parallel Programming Mode)						
V _{IH}	High Level Input Voltage	V _{DD} = 1.8V	●	1.3		V
V _{IL}	Low Level Input Voltage	V _{DD} = 1.8V	●		0.6	V
I _{IN}	Input Current	V _{IN} = 0V to 3.6V	●	-10	10	μA
C _{IN}	Input Capacitance	(Note 8)		3		pF
SDO OUTPUT (Serial Programming Mode. Open-Drain Output. Requires 2k Pull-Up Resistor if SDO is Used)						
R _{OL}	Logic Low Output Resistance to GND	V _{DD} = 1.8V, SDO = 0V		200		Ω
I _{OH}	Logic High Output Leakage Current	SDO = 0V to 3.6V	●	-10	10	μA
C _{OUT}	Output Capacitance	(Note 8)		3		pF
DIGITAL DATA OUTPUTS						
V _{OD}	Differential Output Voltage	100Ω Differential Load, 3.5mA Mode 100Ω Differential Load, 1.75mA Mode	● ●	247 125	350 175	454 250 mV
V _{OS}	Common Mode Output Voltage	100Ω Differential Load, 3.5mA Mode 100Ω Differential Load, 1.75mA Mode	● ●	1.125 1.125	1.250 1.250	1.375 1.375 V
R _{TERM}	On-Chip Termination Resistance	Termination Enabled, 0V _{DD} = 1.8V		100		Ω

POWER REQUIREMENTS

The ● denotes the specifications which apply over the full operating temperature range, otherwise specifications are at $T_A = 25^\circ\text{C}$. (Note 9)

SYMBOL	PARAMETER	CONDITIONS	MIN	TYP	MAX	UNITS
V _{DD}	Analog Supply Voltage	(Note 10)	●	1.7	1.8	1.9 V
OV _{DD}	Output Supply Voltage	(Note 10)	●	1.7	1.8	1.9 V
I _{VDD}	Analog Supply Current	Sine Wave Input	●	93.3	103	mA
I _{OVDD}	Digital Supply Current	1-Lane Mode, 1.75mA Mode 1-Lane Mode, 3.5mA Mode 2-Lane Mode, 1.75mA Mode 2-Lane Mode, 3.5mA Mode 4-Lane Mode, 1.75mA Mode 4-Lane Mode, 3.5mA Mode	● ● ● ● ● ●	9.4 17.5 13.4 25.5 21.9 42	10.7 19.6 15.5 29 25 47	mA
P _{DISS}	Power Dissipation	1-Lane Mode, 1.75mA Mode 1-Lane Mode, 3.5mA Mode 2-Lane Mode, 1.75mA Mode 2-Lane Mode, 3.5mA Mode 4-Lane Mode, 1.75mA Mode 4-Lane Mode, 3.5mA Mode	● ● ● ● ● ●	185 199 192 214 207 244	205 221 214 238 231 270	mW
P _{SLEEP}	Sleep Mode Power			1		mW
P _{NAP}	Nap Mode Power			50		mW
P _{DIFFCLK}	Power Increase with Differential Encode Mode Enabled (No Increase for Sleep Mode)			20		mW

TIMING CHARACTERISTICS

The ● denotes the specifications which apply over the full operating temperature range, otherwise specifications are at $T_A = 25^\circ\text{C}$. (Note 5)

SYMBOL	PARAMETER	CONDITIONS	MIN	TYP	MAX	UNITS	
f_S	Sampling Frequency	(Note 10)	●	5	20	MHz	
t_{ENCL}	ENC Low Time (Note 8)	Duty Cycle Stabilizer Off	●	23.5	25	100	ns
		Duty Cycle Stabilizer On	●	2	25	100	ns
t_{ENCH}	ENC High Time (Note 8)	Duty Cycle Stabilizer Off	●	23.5	25	100	ns
		Duty Cycle Stabilizer On	●	2	25	100	ns
t_{AP}	Sample-and-Hold Acquisition Delay Time			0		ns	

SYMBOL	PARAMETER	CONDITIONS	MIN	TYP	MAX	UNITS	
Digital Data Outputs ($R_{TERM} = 100\Omega$ Differential, $C_L = 2\text{pF}$ to GND On Each Output)							
t_{SER}	Serial Data Bit Period	4-Lane Output Mode 2-Lane Output Mode 1-Lane Output Mode		$1/(4 \cdot f_S)$ $1/(8 \cdot f_S)$ $1/(16 \cdot f_S)$		Sec	
t_{FRAME}	FR to DCO Delay	(Note 8)	●	$0.35 \cdot t_{SER}$	$0.5 \cdot t_{SER}$	$0.65 \cdot t_{SER}$	Sec
t_{DATA}	Data to DCO Delay	(Note 8)	●	$0.35 \cdot t_{SER}$	$0.5 \cdot t_{SER}$	$0.65 \cdot t_{SER}$	Sec
t_{PD}	Propagation Delay	(Note 8)	●	$0.7n + 2 \cdot t_{SER}$	$1.1n + 2 \cdot t_{SER}$	$1.5n + 2 \cdot t_{SER}$	Sec
t_r	Output Rise Time	Data, DCO, FR, 20% to 80%		0.17		ns	
t_f	Output Fall Time	Data, DCO, FR, 20% to 80%		0.17		ns	
	DCO Cycle-Cycle Jitter	$t_{SER} = 3.1\text{ns}$		60		pSp-P	
	Pipeline Latency		7		7	Cycles	

SPI Port Timing (Note 8)

t_{SCK}	SCK Period	Write Mode	●	40		ns
		Readback Mode, $C_{SDO} = 20\text{pF}$, $R_{PULLUP} = 2k$	●	250		ns
t_S	\overline{CS} -to-SCK Setup Time		●	5		ns
t_H	SCK-to- \overline{CS} Setup Time		●	5		ns
t_{DS}	SDI Setup Time		●	5		ns
t_{DH}	SDI Hold Time		●	5		ns
t_{DO}	SCK Falling to SDO Valid	Readback Mode, $C_{SDO} = 20\text{pF}$, $R_{PULLUP} = 2k$	●		125	ns

Note 1: Stresses beyond those listed under Absolute Maximum Ratings may cause permanent damage to the device. Exposure to any Absolute Maximum Rating condition for extended periods may affect device reliability and lifetime.

Note 2: All voltage values are with respect to GND with GND and OGND shorted (unless otherwise noted).

Note 3: When these pin voltages are taken below GND or above V_{DD} , they will be clamped by internal diodes. This product can handle input currents of greater than 100mA below GND or above V_{DD} without latchup.

Note 4: When these pin voltages are taken below GND they will be clamped by internal diodes. When these pin voltages are taken above V_{DD} they will not be clamped by internal diodes. This product can handle input currents of greater than 100mA below GND without latchup.

Note 5: $V_{DD} = OV_{DD} = 1.8\text{V}$, $f_{SAMPLE} = 20\text{MHz}$, 2-lane output mode, differential $ENC^+/ENC^- = 2V_{P-P}$ sine wave, input range = $2.1V_{P-P}$ with differential drive, unless otherwise noted.

Note 6: Integral nonlinearity is defined as the deviation of a code from a best fit straight line to the transfer curve. The deviation is measured from the center of the quantization band.

Note 7: Offset error is the offset voltage measured from -0.5LSB when the output code flickers between 0000 0000 0000 0000 and 1111 1111 1111 1111 in 2's complement output mode.

Note 8: Guaranteed by design, not subject to test.

Note 9: $V_{DD} = OV_{DD} = 1.8\text{V}$, $f_{SAMPLE} = 20\text{MHz}$, 2-lane output mode, ENC^+ = single-ended 1.8V square wave, $ENC^- = 0\text{V}$, input range = $2.1V_{P-P}$ with differential drive, unless otherwise noted. The supply current and power dissipation specifications are totals for the entire IC, not per channel.

Note 10: Recommended operating conditions.

TIMING DIAGRAMS

4-Lane Output Mode

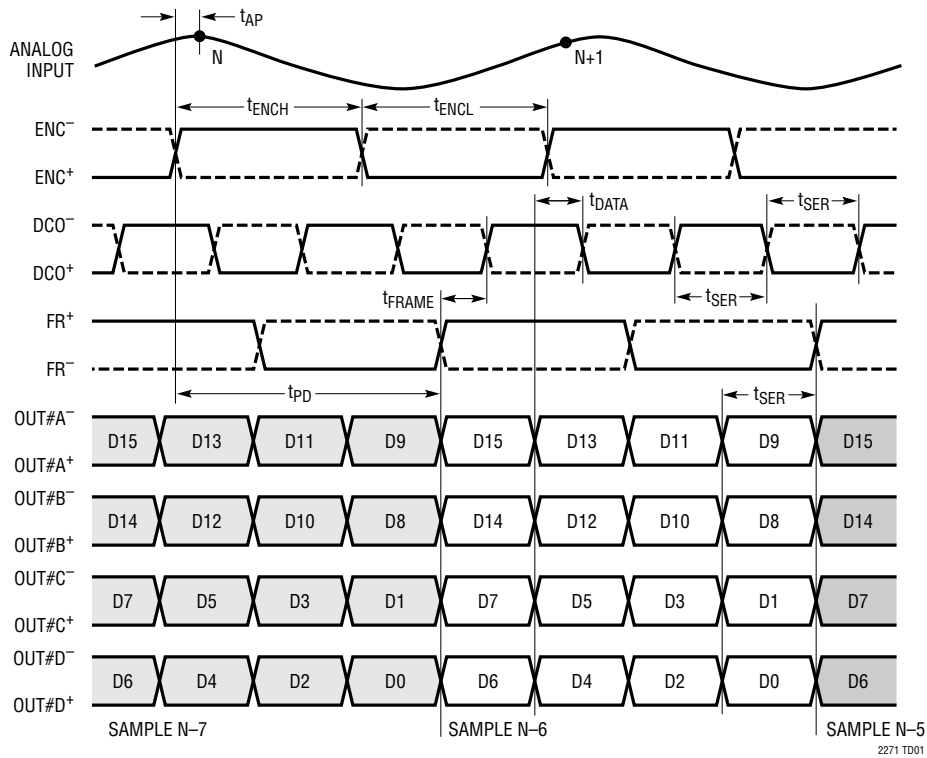

2-Lane Output Mode

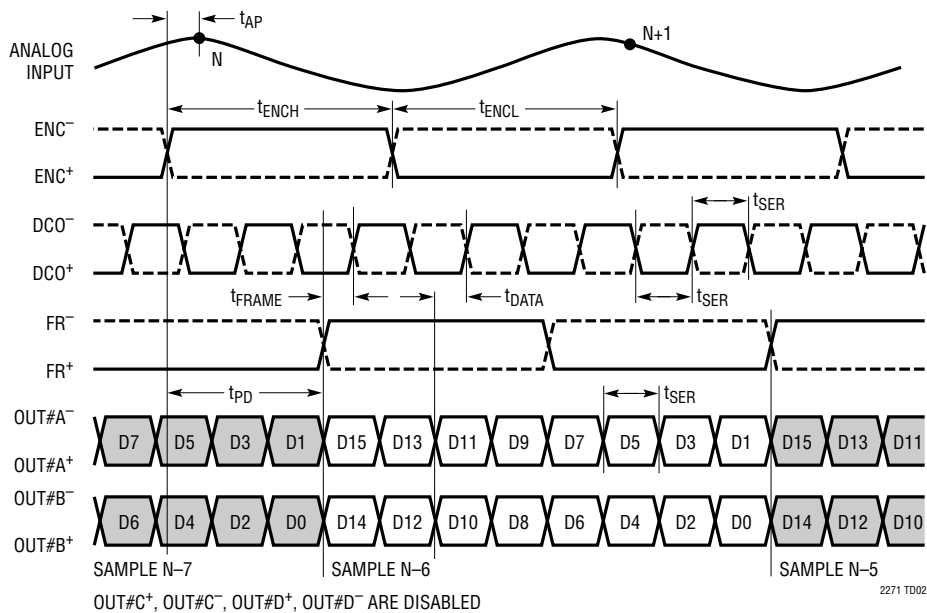

TIMING DIAGRAMS

1-Lane Output Mode

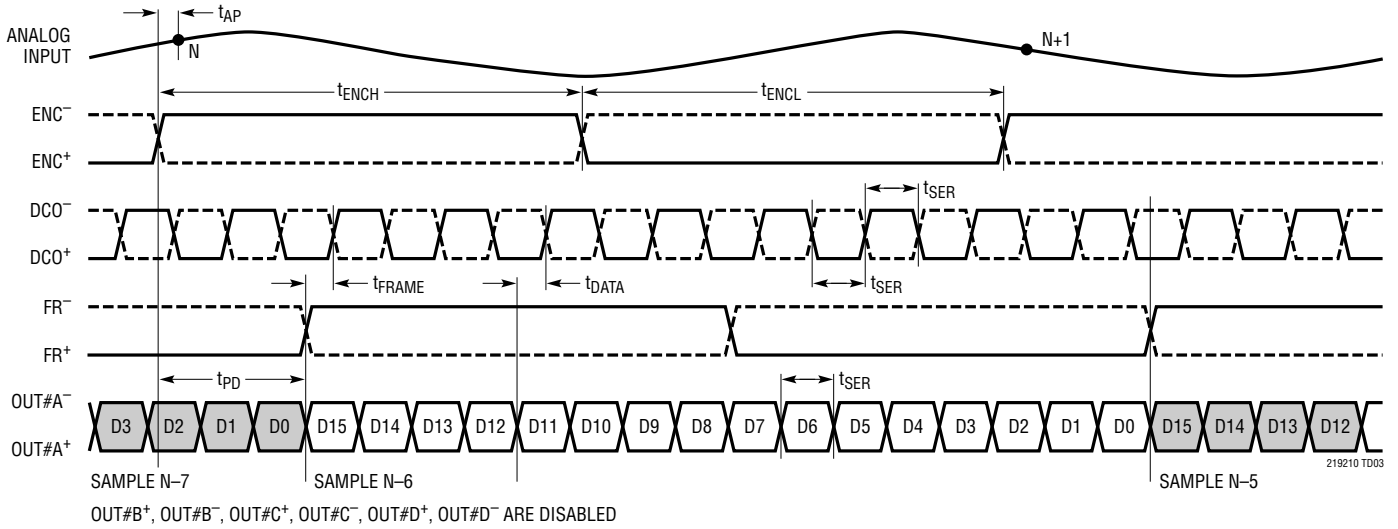

SPI Port Timing (Readback Mode)

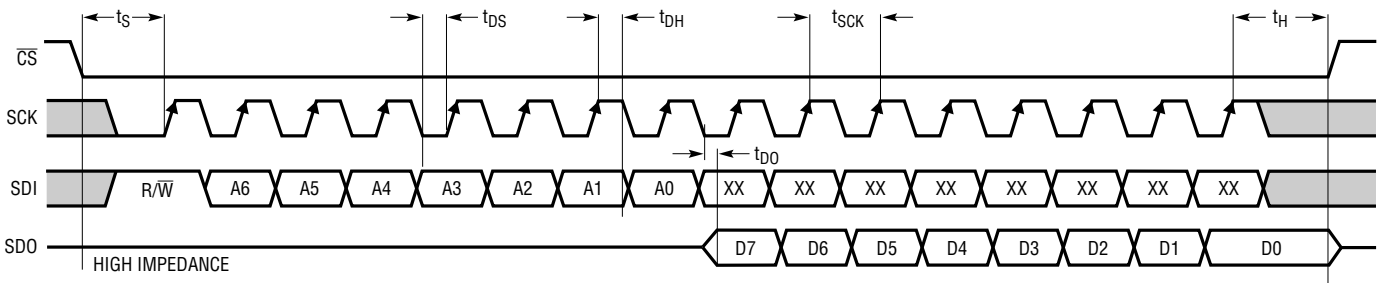

SPI Port Timing (Write Mode)

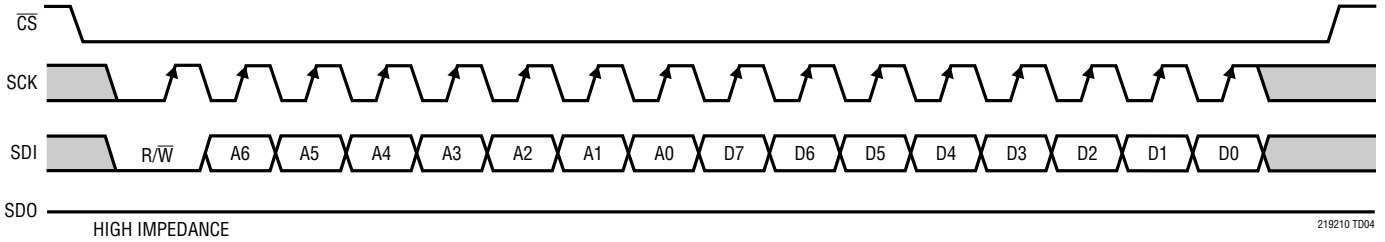

TYPICAL PERFORMANCE CHARACTERISTICS

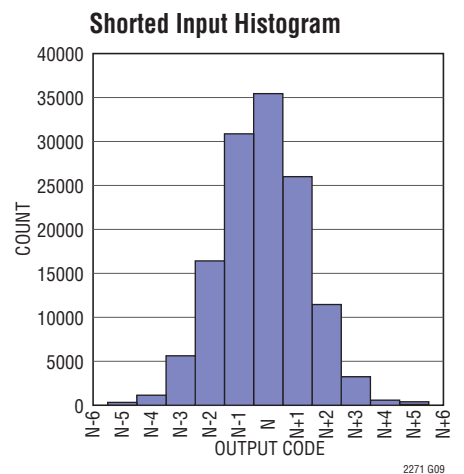
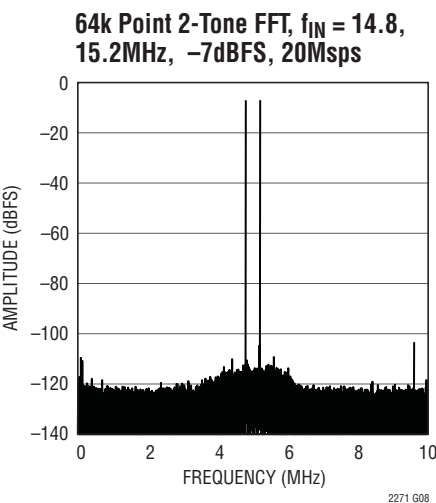
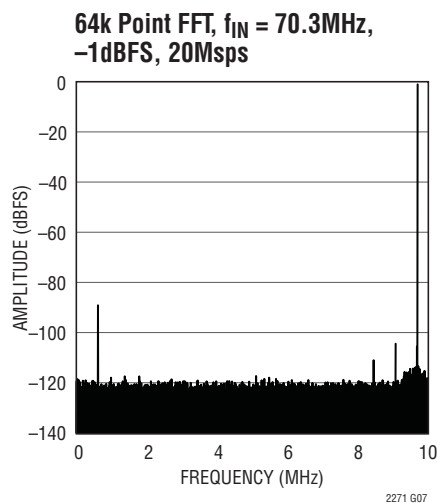
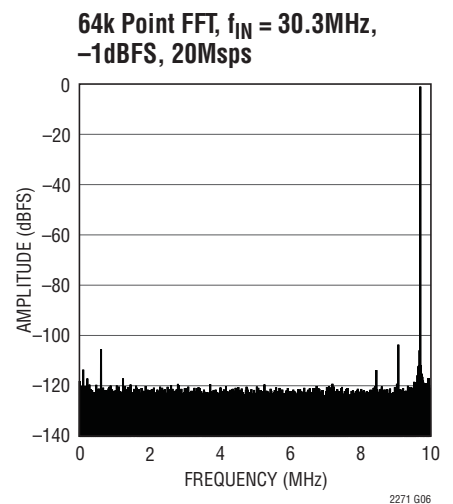
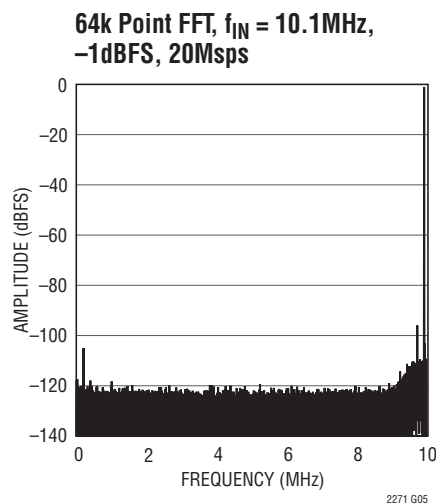
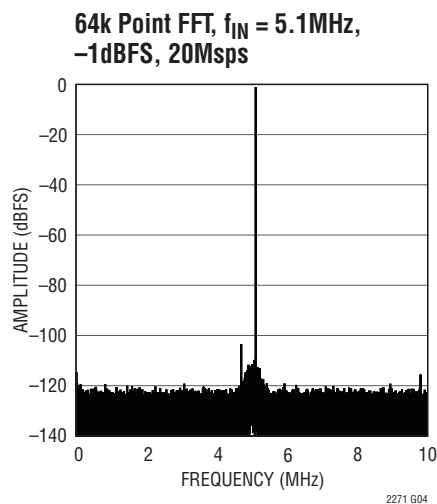
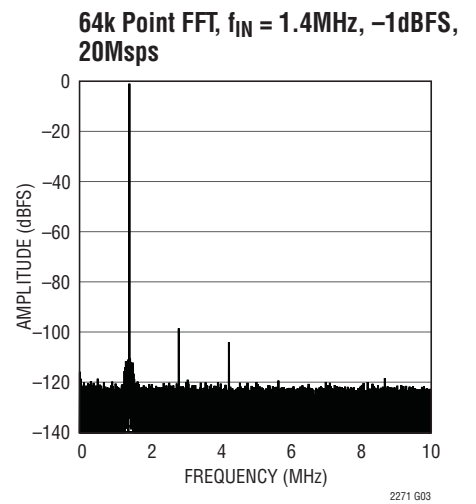
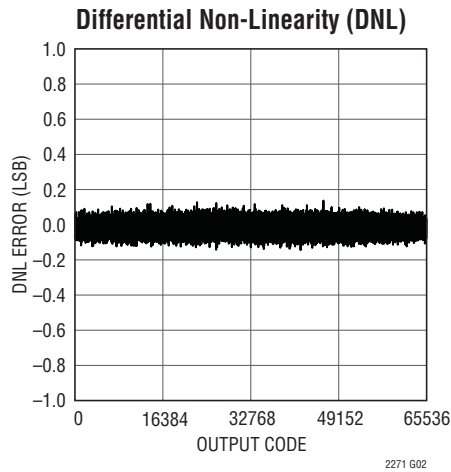
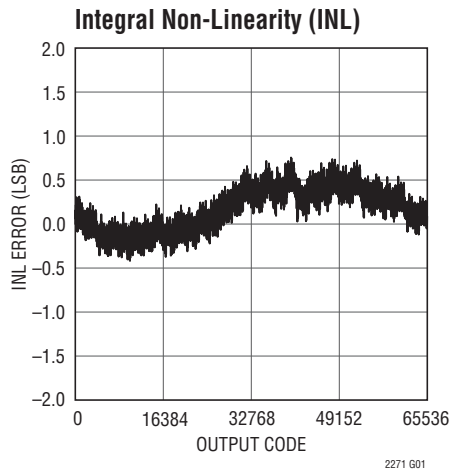

TYPICAL PERFORMANCE CHARACTERISTICS

SNR vs Input Frequency, -1dBFS, 20Mps, 2.1V Range

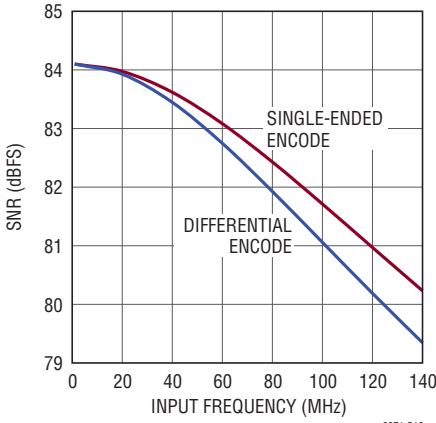

2271 G10

2nd, 3rd Harmonic vs Input Frequency, -1dBFS, 20Mps, 2.1V Range

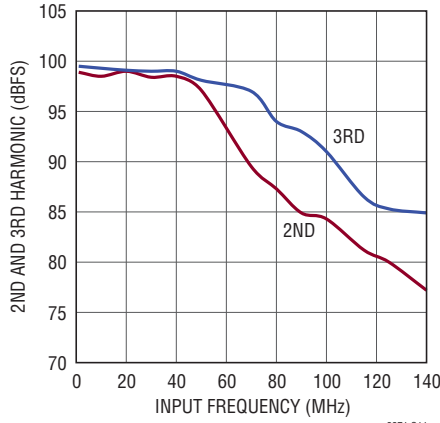

2271 G11

2nd, 3rd Harmonic vs Input Frequency, -1dBFS, 20Mps, 1.05V Range

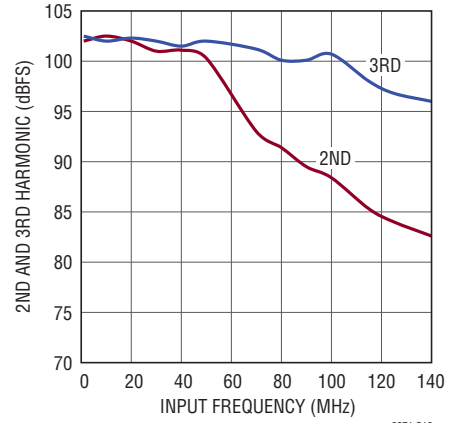

2271 G12

SFDR vs Input Level, $f_{IN} = 5\text{MHz}$, 20Mps, 2.1V Range

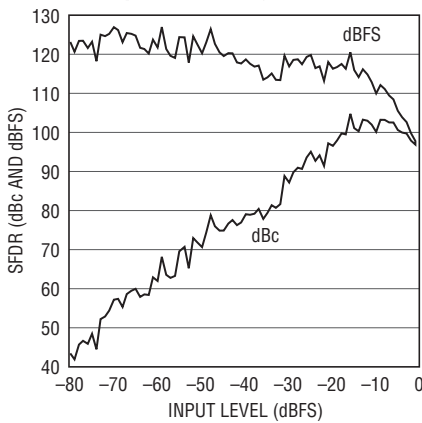

2271 G13

I_{VDD} vs Sample Rate, 5MHz, -1dBFS Sine Wave Input on Each Channel

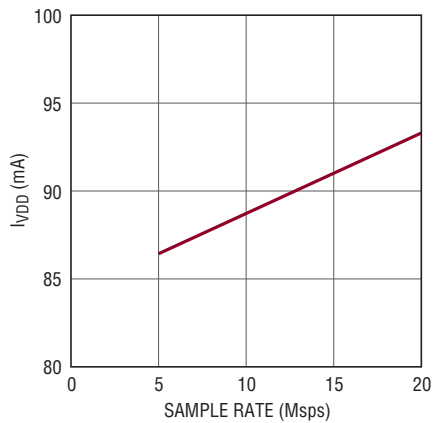

2271 G14

I_{QVDD} vs Sample Rate, 5MHz, -1dBFS Sine Wave Input on Each Channel

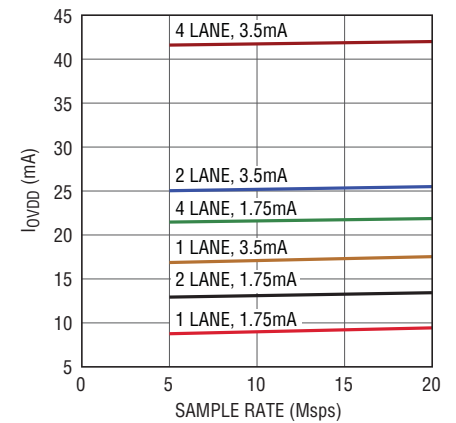

2271 G15

SNR vs SENSE, $f_{IN} = 5\text{MHz}$, -1dBFS

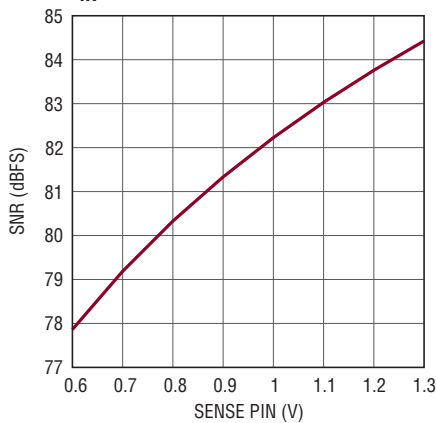

2271 G16

SFDR vs Analog Input Common Mode, $f_{IN} = 9.7\text{MHz}$, 20Mps, 2.1V Range

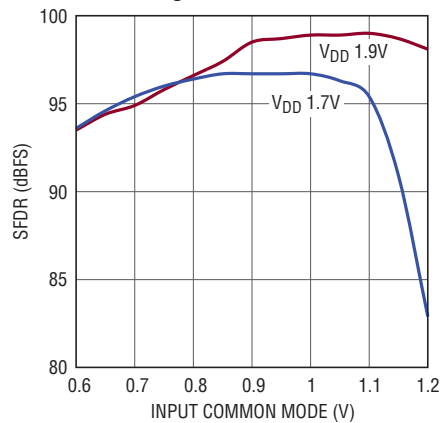

2271 G17

SNR, SFDR vs Sample Rate, $f_{IN} = 5\text{MHz}$, -1dBFS

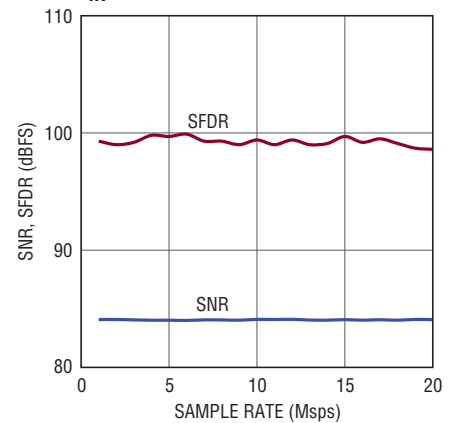

2271 G18

PIN FUNCTIONS

V_{CM1} (Pin 1): Common Mode Bias Output, Nominally Equal to $V_{DD}/2$. V_{CM1} should be used to bias the common mode of the analog inputs of channel 1. Bypass to ground with a 1 μ F ceramic capacitor.

GND (Pins 2, 5, 13, 22, 45, 47, 49, Exposed Pad Pin 53): ADC Power Ground. The exposed pad must be soldered to the PCB ground.

A_{IN1+} (Pin 3): Channel 1 Positive Differential Analog Input.

A_{IN1-} (Pin 4): Channel 1 Negative Differential Analog Input.

REFH (Pins 6, 8): ADC High Reference. See the Reference section in the Applications Information for recommended bypassing circuits for REFH and REFL.

REFL (Pins 7, 9): ADC Low Reference. See the Reference section in the Applications Information for recommended bypassing circuits for REFH and REFL.

PAR/SER (Pin 10): Programming Mode Selection Pin. Connect to ground to enable the serial programming mode. \overline{CS} , SCK, SDI, SDO become a serial interface that control the A/D operating modes. Connect to V_{DD} to enable the parallel programming mode where \overline{CS} , SCK, SDI, SDO become parallel logic inputs that control a reduced set of the A/D operating modes. PAR/SER should be connected directly to ground or the V_{DD} of the part and not be driven by a logic signal.

A_{IN2+} (Pin 11): Channel 2 Positive Differential Analog Input.

A_{IN2-} (Pin 12): Channel 2 Negative Differential Analog Input.

V_{CM2} (Pin 14): Common Mode Bias Output, Nominally Equal to $V_{DD}/2$. V_{CM2} should be used to bias the common mode of the analog inputs of channel 2. Bypass to ground with a 1 μ F ceramic capacitor.

V_{DD} (Pins 15, 16, 51, 52): Analog Power Supply, 1.7V to 1.9V. Bypass to ground with 0.1 μ F ceramic capacitors. Adjacent pins can share a bypass capacitor.

ENC⁺ (Pin 17): Encode Input. Conversion starts on the rising edge.

ENC⁻ (Pin 18): Encode Complement Input. Conversion starts on the falling edge. Tie to GND for single-ended encode mode.

\overline{CS} (Pin 19): In serial programming mode, ($PAR/SER = 0V$), \overline{CS} is the serial interface chip select input. When \overline{CS} is low, SCK is enabled for shifting data on SDI into the mode control registers. In the parallel programming mode ($PAR/SER = V_{DD}$), \overline{CS} along with SCK selects 1-, 2- or 4-lane output mode (see Table 3). \overline{CS} can be driven with 1.8V to 3.3V logic.

SCK (Pin 20): In serial programming mode, ($PAR/SER = 0V$), SCK is the serial interface clock input. In the parallel programming mode ($PAR/SER = V_{DD}$), SCK along with \overline{CS} selects 1-, 2- or 4-lane output mode (see Table 3). SCK can be driven with 1.8V to 3.3V logic.

SDI (Pin 21): In Serial Programming Mode, ($PAR/SER = 0V$), SDI is the Serial Interface Data Input. Data on SDI is clocked into the mode control registers on the rising edge of SCK. In the parallel programming mode ($PAR/SER = V_{DD}$), SDI can be used to power down the part. SDI can be driven with 1.8V to 3.3V logic.

OGND (Pin 33): Output Driver Ground. This pin must be shorted to the ground plane by a very low inductance path. Use multiple vias close to the pin.

OV_{DD} (Pin 34): Output Driver Supply. Bypass to ground with a 0.1 μ F ceramic capacitor.

SDO (Pin 46): In serial programming mode, ($PAR/SER = 0V$), SDO is the optional serial interface data output. Data on SDO is read back from the mode control registers and can be latched on the falling edge of SCK. SDO is an open-drain NMOS output that requires an external 2k pull-up resistor to 1.8V to 3.3V. If read back from the mode control registers is not needed, the pull-up resistor is not necessary and SDO can be left unconnected. In the parallel programming mode ($PAR/SER = V_{DD}$), SDO selects 3.5mA or 1.75mA LVDS output currents. When used as an input, SDO can be driven with 1.8V to 3.3V logic through a 1k series resistor.

V_{REF} (Pin 48): Reference Voltage Output. Bypass to ground with a 2.2 μ F ceramic capacitor. The reference output is nominally 1.25V.

PIN FUNCTIONS

SENSE (Pin 50): Reference Programming Pin. Connecting SENSE to V_{DD} selects the internal reference and a $\pm 1.05V$ input range. Connecting SENSE to ground selects the internal reference and a $\pm 0.525V$ input range. An external reference between 0.625V and 1.3V applied to SENSE selects an input range of $\pm 0.84 \cdot V_{SENSE}$.

LVDS Outputs

The following pins are differential LVDS outputs. The output current level is programmable. There is an optional internal 100Ω termination resistor between the pins of each LVDS output pair.

OUT2D⁻/OUT2D⁺, OUT2C⁻/OUT2C⁺, OUT2B⁻/OUT2B⁺, OUT2A⁻/OUT2A⁺ (Pins 23/24, 25/26, 27/28, 29/30): Serial Data Outputs for Channel 2. In 1-lane output mode only OUT2A⁻/OUT2A⁺ are used. In 2-Lane output mode only OUT2A⁻/OUT2A⁺ and OUT2B⁻/OUT2B⁺ are used.

FR⁻/FR⁺ (Pins 31/32): Frame Start Outputs.

DCO⁻/DCO⁺ (Pins 35/36): Data Clock Outputs.

OUT1D⁻/OUT1D⁺, OUT1C⁻/OUT1C⁺, OUT1B⁻/OUT1B⁺, OUT1A⁻/OUT1A⁺ (Pins 37/38, 39/40, 41/42, 43/44): Serial Data Outputs for Channel 1. In 1-lane output mode only OUT1A⁻/OUT1A⁺ are used. In 2-lane output mode only OUT1A⁻/OUT1A⁺ and OUT1B⁻/OUT1B⁺ are used.

FUNCTIONAL BLOCK DIAGRAM

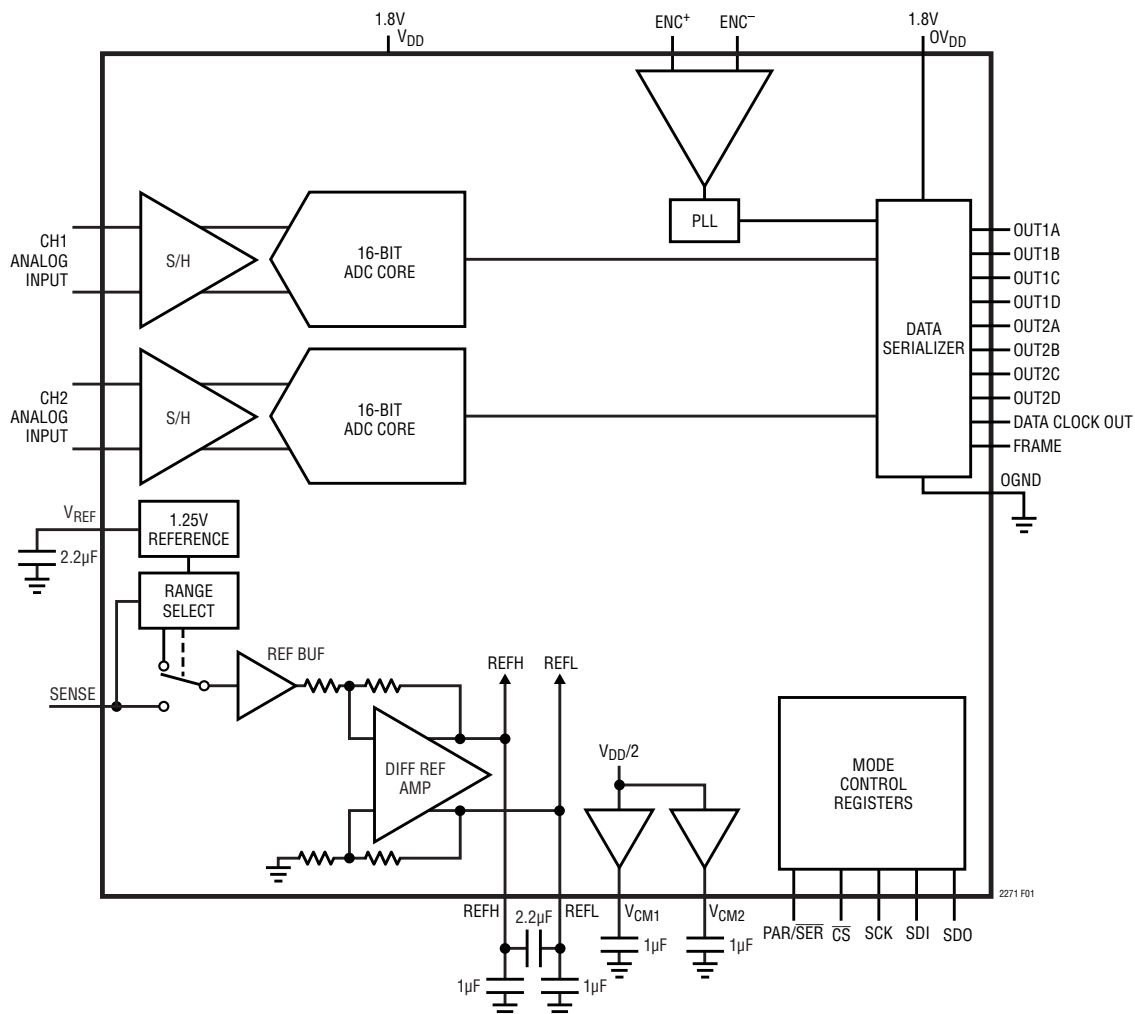

Figure 1. Functional Block Diagram

APPLICATIONS INFORMATION

CONVERTER OPERATION

The LTC2271 is a low power, 2-channel, 16-bit, 20Msps A/D converter that is powered by a single 1.8V supply. The analog inputs must be driven differentially. The encode input can be driven differentially or single ended for lower power consumption. To minimize the number of data lines the digital outputs are serial LVDS. Each channel outputs one bit at a time (1-lane mode), two bits at a time (2-lane mode) or four bits at a time (4-lane mode). Many additional features can be chosen by programming the mode control registers through a serial SPI port.

ANALOG INPUT

The analog inputs are differential CMOS sample-and-hold circuits (Figure 2). The inputs should be driven differentially around a common mode voltage set by the V_{CM1} or V_{CM2} output pins, which are nominally $V_{DD}/2$. For the 2.1V input range, the inputs should swing from $V_{CM} - 525\text{mV}$ to $V_{CM} + 525\text{mV}$. There should be 180° phase difference between the inputs.

The two channels are simultaneously sampled by a shared encode circuit (Figure 2).

INPUT DRIVE CIRCUITS

Input Filtering

If possible, there should be an RC lowpass filter right at the analog inputs. This lowpass filter isolates the drive circuitry from the A/D sample-and-hold switching, and also limits wideband noise from the drive circuitry. Figure 3 shows an example of an input RC filter. The RC component values should be chosen based on the application's input frequency.

Transformer Coupled Circuits

Figure 3 shows the analog input being driven by an RF transformer with a center-tapped secondary. The center tap is biased with V_{CM} , setting the A/D input at its optimal DC level. At higher input frequencies a transmission line balun transformer (Figures 4 to 5) has better balance, resulting in lower A/D distortion.

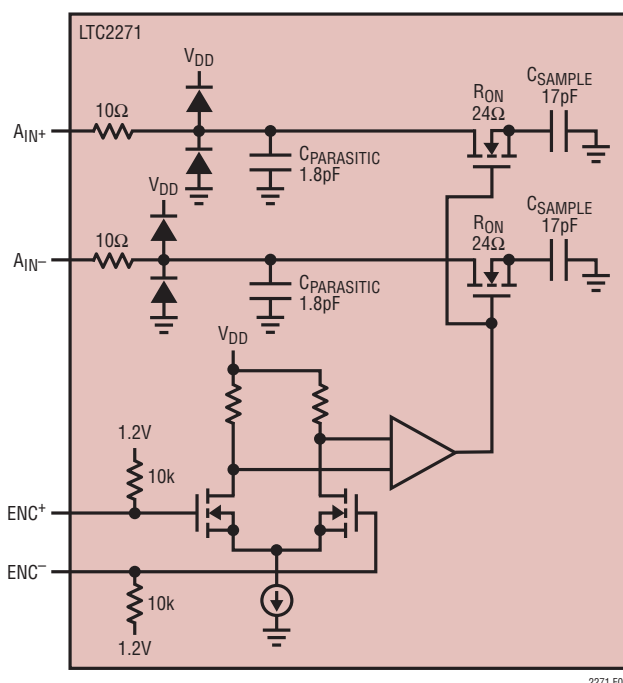

Figure 2. Equivalent Input Circuit. Only One of Two Analog Channels Is Shown

APPLICATIONS INFORMATION

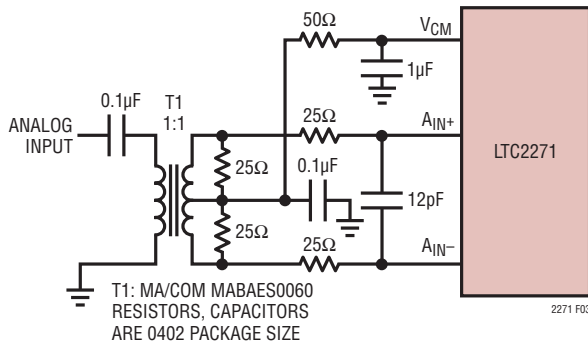

Figure 3. Analog Input Circuit Using a Transformer.
Recommended for Input Frequencies from 1MHz to 40MHz

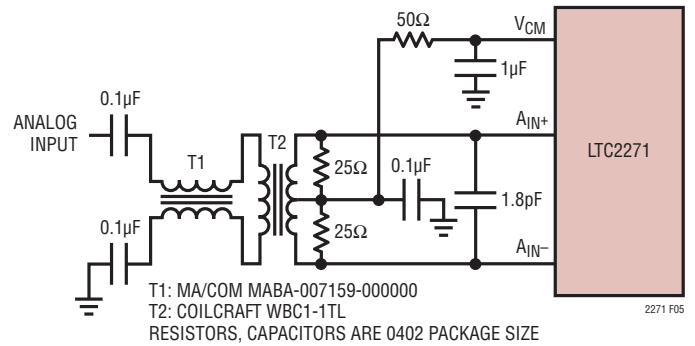

Figure 5. Recommended Front-End Circuit for Input Frequencies Above 80MHz

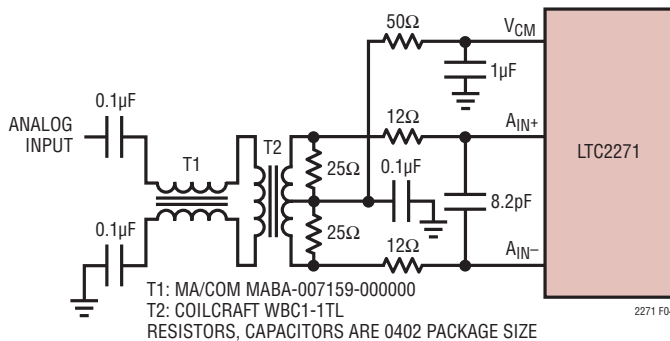

Figure 4. Recommended Front-End Circuit for Input Frequencies from 5MHz to 80MHz

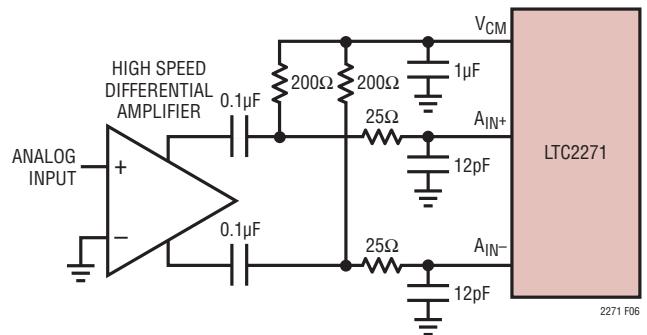

Figure 6. Front-End Circuit Using a High Speed Differential Amplifier

Amplifier Circuits

Figure 6 shows the analog input being driven by a high speed differential amplifier. The output of the amplifier is AC coupled to the A/D so the amplifier's output common mode voltage can be optimally set to minimize distortion.

If DC coupling is necessary use a differential amplifier with an output common mode set by the LTC2271 V_{CM} pin (Figure 7).

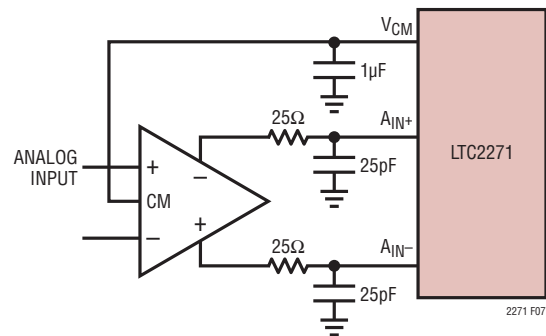

Figure 7. DC-Coupled Amplifier

APPLICATIONS INFORMATION

Reference

The LTC2271 has an internal 1.25V voltage reference. For a 2.1V input range using the internal reference, connect SENSE to V_{DD} . For a 1.05V input range using the internal reference, connect SENSE to ground. For a 2.1V input range with an external reference, apply a 1.25V reference voltage to SENSE (Figure 9).

The input range can be adjusted by applying a voltage to SENSE that is between 0.625V and 1.30V. The input range will then be $1.68 \cdot V_{SENSE}$.

The V_{REF} , REFH and REFL pins should be bypassed as shown in Figure 8. A low inductance 2.2 μ F interdigitated capacitor is recommended for the bypass between REFH and REFL. This type of capacitor is available at a low cost from multiple suppliers.

Alternatively, C1 can be replaced by a standard 2.2 μ F capacitor between REFH and REFL. The capacitors should be as close to the pins as possible (not on the back side of the circuit board).

Figure 8c and 8d show the recommended circuit board layout for the REFH/REFL bypass capacitors. Note that in Figure 8c, every pin of the interdigitated capacitor (C1) is connected since the pins are not internally connected in some vendors' capacitors. In Figure 8d the REFH and REFL pins are connected by short jumpers in an internal layer. To minimize the inductance of these jumpers they can be placed in a small hole in the GND plane on the second board layer.

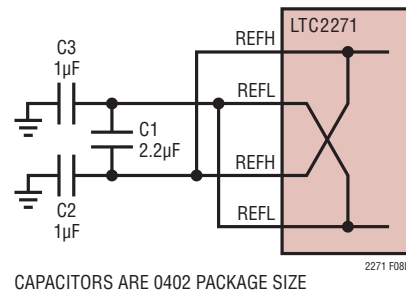

CAPACITORS ARE 0402 PACKAGE SIZE

Figure 8b. Alternative REFH/REFL Bypass Circuit

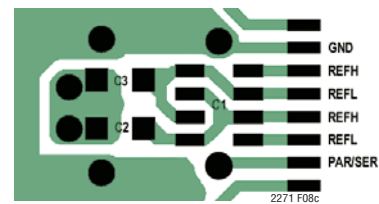

Figure 8c. Recommended Layout for the REFH/REFL Bypass Circuit in Figure 8a

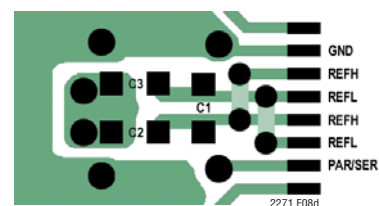

Figure 8d. Recommended Layout for the REFH/REFL Bypass Circuit in Figure 8b

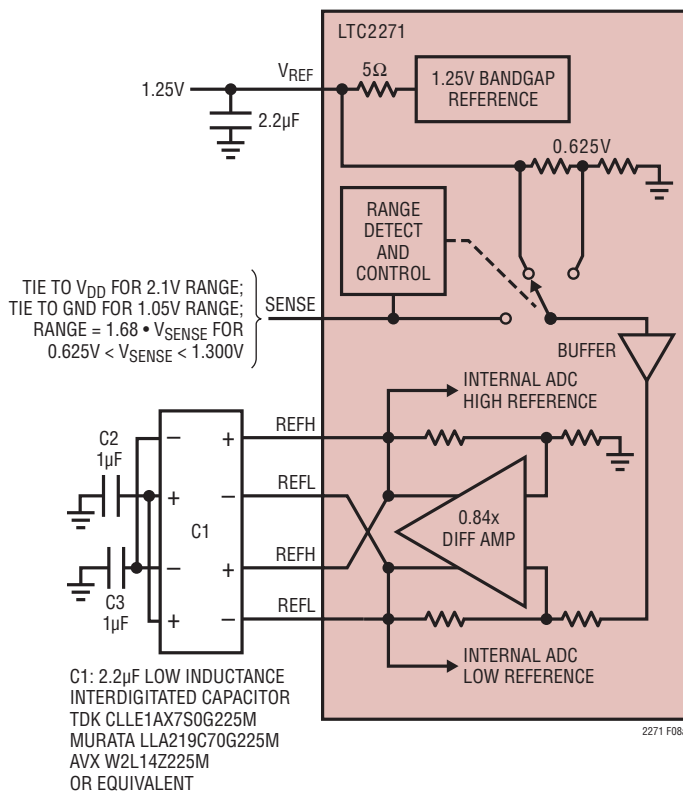

Figure 8a. Reference Circuit

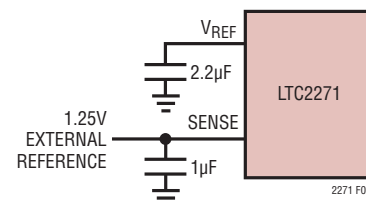

Figure 9. Using an External 1.25V Reference

APPLICATIONS INFORMATION

Encode Input

The signal quality of the encode inputs strongly affects the A/D noise performance. The encode inputs should be treated as analog signals—do not route them next to digital traces on the circuit board. There are two modes of operation for the encode inputs: the differential encode mode (Figure 10), and the single-ended encode mode (Figure 11).

The differential encode mode is recommended for sinusoidal, PECL, or LVDS encode inputs (Figures 12, 13). The encode inputs are internally biased to 1.2V through 10k equivalent resistance. The encode inputs can be taken above V_{DD} (up to 3.6V), and the common mode range is from 1.1V to 1.6V. In the differential encode mode, ENC^- should stay at least 200mV above ground to avoid falsely triggering the single-ended encode mode. For good jitter performance ENC^+ should have fast rise and fall times.

The single-ended encode mode should be used with CMOS encode inputs. To select this mode, ENC^- is connected to ground and ENC^+ is driven with a square wave

encode input. ENC^+ can be taken above V_{DD} (up to 3.6V) so 1.8V to 3.3V CMOS logic levels can be used. The ENC^+ threshold is 0.9V. For good jitter performance ENC^+ should have fast rise and fall times. If the encode signal is turned off or drops below approximately 500kHz, the A/D enters nap mode.

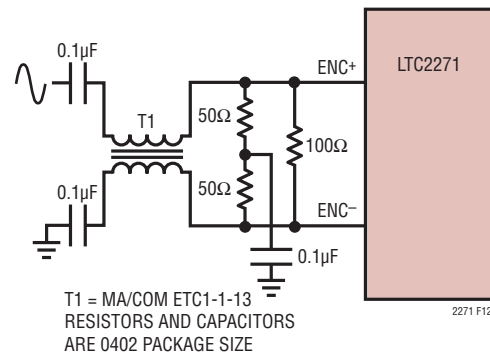

Figure 12. Sinusoidal Encode Drive

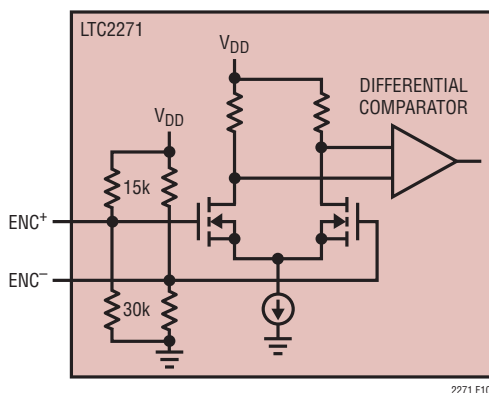

Figure 10. Equivalent Encode Input Circuit for Differential Encode Mode

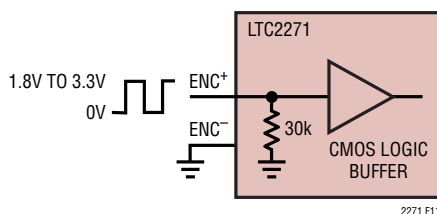

Figure 11. Equivalent Encode Input Circuit for Single-Ended Encode Mode

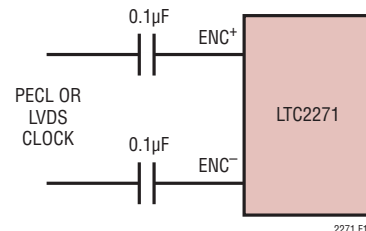

Figure 13. PECL or LVDS Encode Drive

Clock PLL and Duty Cycle Stabilizer

The encode clock is multiplied by an internal phase-locked loop (PLL) to generate the serial digital output data. If the encode signal changes frequency or is turned off, the PLL requires 25µs to lock onto the input clock.

A clock duty cycle stabilizer circuit allows the duty cycle of the applied encode signal to vary from 30% to 70%. In the serial programming mode it is possible to disable the duty cycle stabilizer, but this is not recommended. In the parallel programming mode the duty cycle stabilizer is always enabled.

APPLICATIONS INFORMATION

DIGITAL OUTPUTS

The digital outputs of the LTC2271 are serialized LVDS signals. Each channel outputs one bit at a time (1-lane mode), two bits at a time (2-lane mode) or four bits at a time (4-lane mode). Please refer to the Timing Diagrams for details. In 4-lane mode the clock duty cycle stabilizer must be enabled.

The output data should be latched on the rising and falling edges of the data clock out (DCO). A data frame output (FR) can be used to determine when the data from a new conversion result begins.

The minimum sample rate for all serialization modes is 5Msps.

By default the outputs are standard LVDS levels: 3.5mA output current and a 1.25V output common mode voltage. An external 100Ω differential termination resistor is required for each LVDS output pair. The termination resistors should be located as close as possible to the LVDS receiver.

The outputs are powered by OV_{DD} which is isolated from the A/D core power.

Table 1. Maximum Sampling Frequency for All Serialization Modes

SERIALIZATION MODE	MAXIMUM SAMPLING FREQUENCY, f_s (MHz)	DCO FREQUENCY	FR FREQUENCY	SERIAL DATA RATE
4-Lane	20	$2 \cdot f_s$	f_s	$4 \cdot f_s$
2-Lane	20	$4 \cdot f_s$	f_s	$8 \cdot f_s$
1-Lane	20	$8 \cdot f_s$	f_s	$16 \cdot f_s$

Programmable LVDS Output Current

In LVDS mode, the default output driver current is 3.5mA. This current can be adjusted by control register A2 in the serial programming mode. Available current levels are 1.75mA, 2.1mA, 2.5mA, 3mA, 3.5mA, 4mA and 4.5mA. In the parallel programming mode the SDO pin can select either 3.5mA or 1.75mA.

Optional LVDS Driver Internal Termination

In most cases using just an external 100Ω termination resistor will give excellent LVDS signal integrity. In addition, an optional internal 100Ω termination resistor can be enabled by serially programming mode control register A2. The internal termination helps absorb any reflections caused by imperfect termination at the receiver. When the internal termination is enabled, the output driver current is doubled to maintain the same output voltage swing. Internal termination can only be selected in serial programming mode.

DATA FORMAT

Table 2 shows the relationship between the analog input voltage and the digital data output bits. By default the output data format is offset binary. The 2's complement format can be selected by serially programming mode control register A1.

Table 2. Output Codes vs Input Voltage

$A_{IN}^+ - A_{IN}^-$ (2V RANGE)	D15-D0 (OFFSET BINARY)	D15-D0 (2's COMPLEMENT)
>1.000000V	1111 1111 1111 1111	0111 1111 1111 1111
+0.999970V	1111 1111 1111 1111	0111 1111 1111 1111
+0.999939V	1111 1111 1111 1110	0111 1111 1111 1110
+0.000030V	1000 0000 0000 0001	0000 0000 0000 0001
+0.000000V	1000 0000 0000 0000	0000 0000 0000 0000
-0.000030V	0111 1111 1111 1111	1111 1111 1111 1111
-0.000061V	0111 1111 1111 1110	1111 1111 1111 1110
-0.999939V	0000 0000 0000 0001	1000 0000 0000 0001
-1.000000V	0000 0000 0000 0000	1000 0000 0000 0000
<-1.000000V	0000 0000 0000 0000	1000 0000 0000 0000

Digital Output Randomizer

Interference from the A/D digital outputs is sometimes unavoidable. Digital interference may be from capacitive or inductive coupling or coupling through the ground plane. Even a tiny coupling factor can cause unwanted tones in the ADC output spectrum. By randomizing the digital output before it is transmitted off-chip, these unwanted tones can be randomized which reduces the unwanted tone amplitude.

APPLICATIONS INFORMATION

The digital output is randomized by applying an exclusive OR logic operation between the LSB and all other data output bits. To decode, the reverse operation is applied—an exclusive OR operation is applied between the LSB and all other bits. The FR and DCO outputs are not affected. The output randomizer is enabled by serially programming mode control register A1.

Digital Output Test Pattern

To allow in-circuit testing of the digital interface to the A/D, there is a test mode that forces the A/D data outputs (D15-D0) of both channels to known values. The digital output test patterns are enabled by serially programming mode control registers A2, A3 and A4. When enabled, the test patterns override all other formatting modes: 2's complement and randomizer.

Output Disable

The digital outputs may be disabled by serially programming mode control register A2. The current drive for all digital outputs including DCO and FR are disabled to save power or enable in-circuit testing. When disabled the common mode of each output pair becomes high impedance, but the differential impedance may remain low.

Sleep and Nap Modes

The A/D may be placed in sleep or nap modes to conserve power. In sleep mode the entire device is powered down, resulting in 1mW power consumption. Sleep mode is enabled by mode control register A1 (serial programming mode), or by SDI (parallel programming mode). The amount of time required to recover from sleep mode depends on the size of the bypass capacitors on V_{REF} , REFH and REFL. For the suggested values in Figure 8, the A/D will stabilize after 2ms.

In nap mode any combination of A/D channels can be powered down while the internal reference circuits and the PLL stay active, allowing faster wake up than from sleep mode. Recovering from nap mode requires at least 100 clock cycles. If the application demands very accurate DC settling then an additional 50 μ s should be allowed so the on-chip references can settle from the slight temperature shift caused by the change in supply current as the A/D

leaves nap mode. Nap mode is enabled by mode control register A1 in the serial programming mode.

DEVICE PROGRAMMING MODES

The operating modes of the LTC2271 can be programmed by either a parallel interface or a simple serial interface. The serial interface has more flexibility and can program all available modes. The parallel interface is more limited and can only program some of the more commonly used modes.

Parallel Programming Mode

To use the parallel programming mode, $\overline{\text{PAR}}/\overline{\text{SER}}$ should be tied to V_{DD} . The $\overline{\text{CS}}$, SCK, SDI and SDO pins are binary logic inputs that set certain operating modes. These pins can be tied to V_{DD} or ground, or driven by 1.8V, 2.5V or 3.3V CMOS logic. When used as an input, SDO should be driven through a 1k series resistor. Table 3 shows the modes set by $\overline{\text{CS}}$, SCK, SDI and SDO.

Table 3. Parallel Programming Mode Control Bits ($\overline{\text{PAR}}/\overline{\text{SER}} = V_{DD}$)

PIN	DESCRIPTION
$\overline{\text{CS}}/\text{SCK}$	2-Lane/4-Lane/1-Lane Selection Bits 00 = 2-Lane Output Mode 01 = 4-Lane Output Mode 10 = 1-Lane Output Mode 11 = Not Used
SDI	Power Down Control Bit 0 = Normal Operation 1 = Sleep Mode
SDO	LVDS Current Selection Bit 0 = 3.5mA LVDS Current Mode 1 = 1.75mA LVDS Current Mode

Serial Programming Mode

To use the serial programming mode, $\overline{\text{PAR}}/\overline{\text{SER}}$ should be tied to ground. The $\overline{\text{CS}}$, SCK, SDI and SDO pins become a serial interface that program the A/D mode control registers. Data is written to a register with a 16-bit serial word. Data can also be read back from a register to verify its contents.

Serial data transfer starts when $\overline{\text{CS}}$ is taken low. The data on the SDI pin is latched at the first 16 rising edges of SCK. Any SCK rising edges after the first 16 are ignored. The data transfer ends when $\overline{\text{CS}}$ is taken high again.

APPLICATIONS INFORMATION

The first bit of the 16-bit input word is the R/\overline{W} bit. The next seven bits are the address of the register (A6:A0). The final eight bits are the register data (D7:D0).

If the R/\overline{W} bit is low, the serial data (D7:D0) will be written to the register set by the address bits (A6:A0). If the R/\overline{W} bit is high, data in the register set by the address bits (A6:A0) will be read back on the SDO pin (see the Timing Diagrams). During a read back command the register is not updated and data on SDI is ignored.

The SDO pin is an open-drain output that pulls to ground with a 200 Ω impedance. If register data is read back through SDO, an external 2k pull-up resistor is required. If serial data is only written and read back is not needed,

then SDO can be left floating and no pull-up resistor is needed.

Table 4 shows a map of the mode control registers.

Software Reset

If serial programming is used, the mode control registers should be programmed as soon as possible after the power supplies turn on and are stable. The first serial command must be a software reset which will reset all register data bits to logic 0. To perform a software reset, bit D7 in the reset register is written with a logic 1. After the reset SPI write command is complete, bit D7 is automatically set back to zero.

Table 4. Serial Programming Mode Register Map (PAR/ \overline{SER} = GND)

REGISTER A0: RESET REGISTER (ADDRESS 00h)

D7	D6	D5	D4	D3	D2	D1	D0
RESET	X	X	X	X	X	X	X

Bit 7 **RESET** Software Reset Bit
 0 = Not Used
 1 = Software Reset. All Mode Control Registers are Reset to 00h. The ADC is Momentarily Placed in Sleep Mode. This Bit is Automatically Set Back to Zero at the end of the SPI write command. The Reset register is write-only. Data read back from the Reset register will be random.

Bits 6-0 Unused, Don't Care Bits.

REGISTER A1: FORMAT AND POWER-DOWN REGISTER (ADDRESS 01h)

D7	D6	D5	D4	D3	D2	D1	D0
DCSOFF	RAND	TWOSCOMP	SLEEP	NAP_2	X	X	NAP_1

Bit 7 **DCSOFF** Clock Duty Cycle Stabilizer Bit
 0 = Clock Duty Cycle Stabilizer On
 1 = Clock Duty Cycle Stabilizer Off. This is not recommended.

Bit 6 **RAND** Data Output Randomizer Mode Control Bit
 0 = Data Output Randomizer Mode Off
 1 = Data Output Randomizer Mode On

Bit 5 **TWOSCOMP** Two's Complement Mode Control Bit
 0 = Offset Binary Data Format
 1 = Two's Complement Data Format

Bits 4, 3, 0 **SLEEP:NAP_2:NAP_1** Sleep/Nap Mode Control Bits
 000 = Normal Operation
 0X1 = Channel 1 in Nap Mode
 01X = Channel 2 in Nap Mode
 1XX = Sleep Mode. Both Channels are Disabled.
 Note: Any Combination of Channels Can Be Placed in Nap Mode

Bits 1, 2 Unused, Don't Care Bits

APPLICATIONS INFORMATION

REGISTER A2: OUTPUT MODE REGISTER (ADDRESS 02h)

D7	D6	D5	D4	D3	D2	D1	D0
ILVDS2	ILVDS1	ILVDS0	TERMON	OUTOFF	OUTTEST	OUTMODE1	OUTMODE0
Bits 7-5	ILVDS2:ILVDS0 LVDS Output Current Bits 000 = 3.5mA LVDS Output Driver Current 001 = 4.0mA LVDS Output Driver Current 010 = 4.5mA LVDS Output Driver Current 011 = Not Used 100 = 3.0mA LVDS Output Driver Current 101 = 2.5mA LVDS Output Driver Current 110 = 2.1mA LVDS Output Driver Current 111 = 1.75mA LVDS Output Driver Current						
Bit 4	TERMON LVDS Internal Termination Bit 0 = Internal Termination Off 1 = Internal Termination On. LVDS Output Driver Current is 2x the Current Set by ILVDS2:ILVDS0						
Bit 3	OUTOFF Output Disable Bit 0 = Digital Outputs are Enabled 1 = Digital Outputs are Disabled						
Bit 2	OUTTEST Digital Output Test Pattern Control Bit 0 = Digital Output Test Pattern Off 1 = Digital Output Test Pattern On						
Bits 1-0	OUTMODE1:OUTMODE0 Digital Output Mode Control Bits 00 = 2-Lane Output Mode 01 = 4-Lane Output Mode 10 = 1-Lane Output Mode 11 = Not Used						

REGISTER A3: TEST PATTERN MSB REGISTER (ADDRESS 03h)

D7	D6	D5	D4	D3	D2	D1	D0
TP15	TP14	TP13	TP12	TP11	TP10	TP9	TP8
Bits 7-0	TP15:TP8 Test Pattern Data Bits (MSB) TP15:TP8 Set the Test Pattern for Data Bit 15 (MSB) Through Data Bit 8.						

REGISTER A4: TEST PATTERN LSB REGISTER (ADDRESS 04h)

D7	D6	D5	D4	D3	D2	D1	D0
TP7	TP6	TP5	TP4	TP3	TP2	TP1	TP0
Bits 7-0	TP7:TP0 Test Pattern Data Bits (LSB) TP7:TP0 Set the Test Pattern for Data Bit 7 Through Data Bit 0 (LSB).						

APPLICATIONS INFORMATION

GROUNDING AND BYPASSING

The LTC2271 require a printed circuit board with a clean unbroken ground plane. A multilayer board with an internal ground plane in the first layer beneath the ADC is recommended. Layout for the printed circuit board should ensure that digital and analog signal lines are separated as much as possible. In particular, care should be taken not to run any digital track alongside an analog signal track or underneath the ADC.

High quality ceramic bypass capacitors should be used at the V_{DD} , OV_{DD} , V_{CM} , V_{REF} , $REFH$ and $REFL$ pins. Bypass capacitors must be located as close to the pins as possible. Size 0402 ceramic capacitors are recommended. The traces connecting the pins and bypass capacitors must be kept short and should be made as wide as possible.

Of particular importance is the capacitor between $REFH$ and $REFL$. This capacitor should be on the same side of the circuit board as the A/D, and as close to the device as possible.

The analog inputs, encode signals, and digital outputs should not be routed next to each other. Ground fill and grounded vias should be used as barriers to isolate these signals from each other.

HEAT TRANSFER

Most of the heat generated by the LTC2271 is transferred from the die through the bottom-side exposed pad and package leads onto the printed circuit board. For good electrical and thermal performance, the exposed pad must be soldered to a large grounded pad on the PC board. This pad should be connected to the internal ground planes by an array of vias.

TYPICAL APPLICATIONS

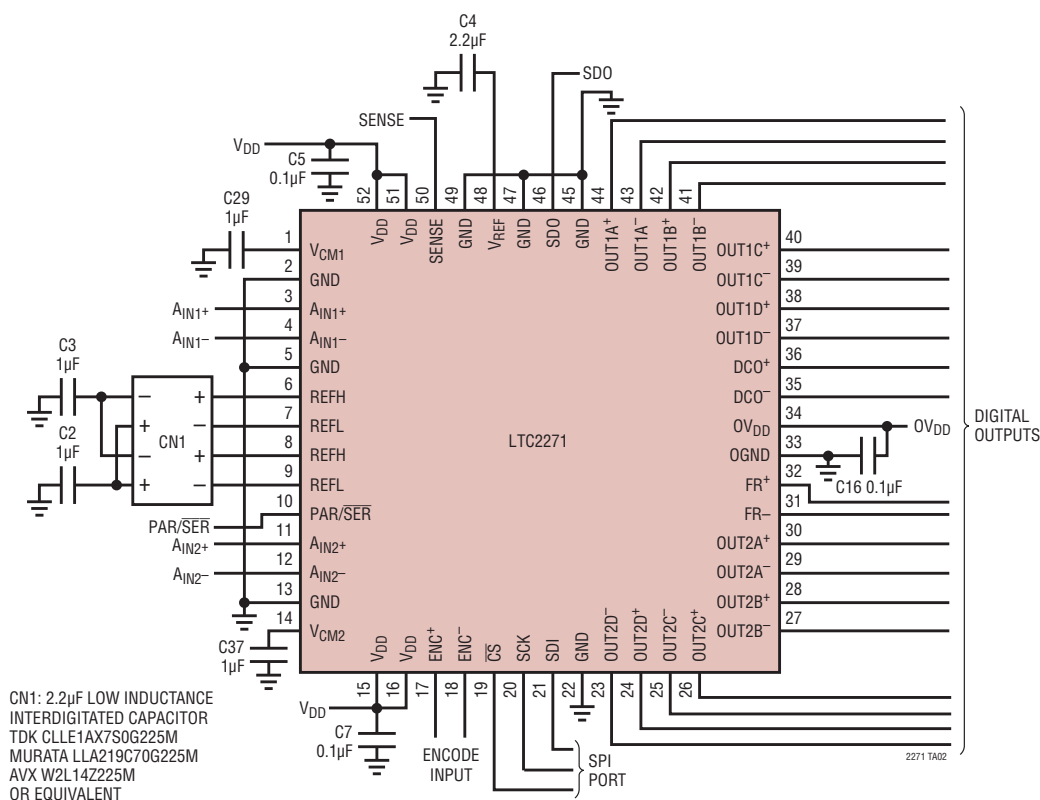

TYPICAL APPLICATIONS

Top Side

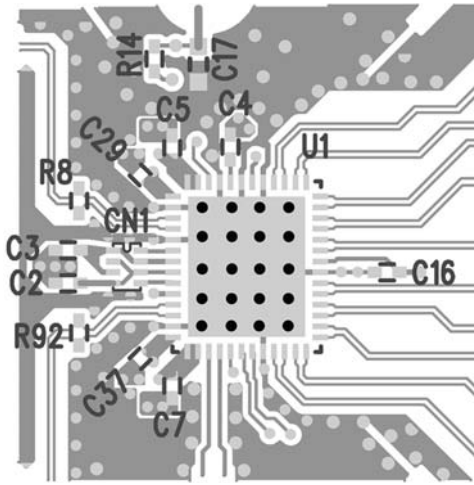

Inner Layer 2

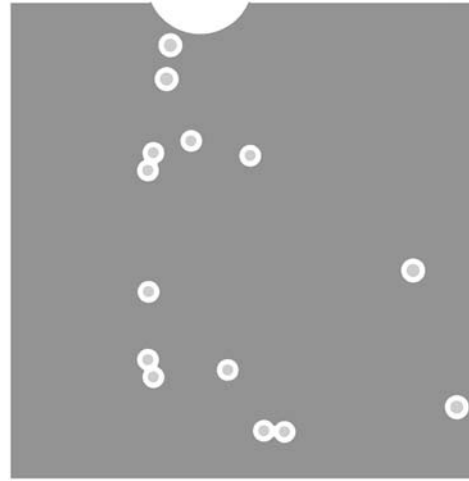

Inner Layer 3

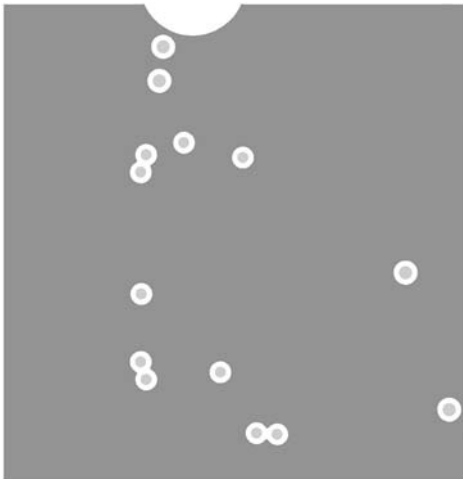

Inner Layer 4



Inner Layer 5



Bottom Side

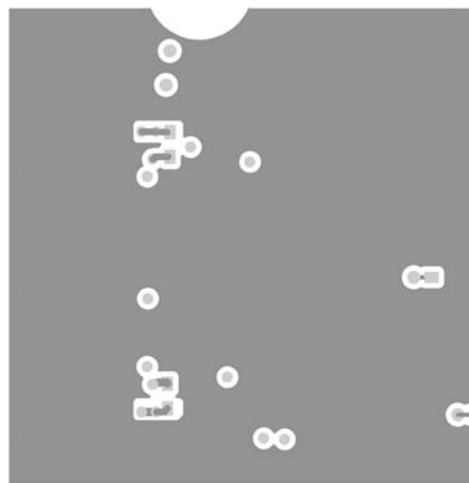

PACKAGE DESCRIPTION

UKG Package
52-Lead Plastic QFN (7mm × 8mm)
 (Reference LTC DWG # 05-08-1729 Rev 0)

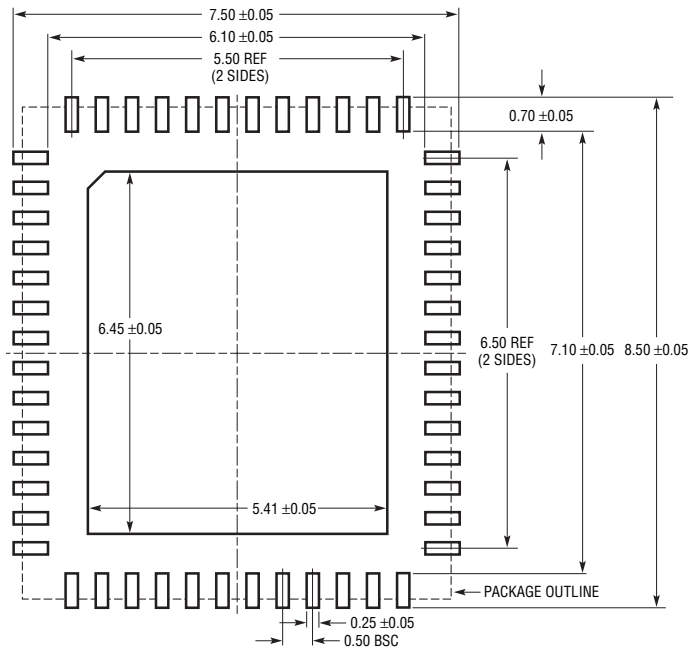

RECOMMENDED SOLDER PAD PITCH AND DIMENSIONS
 APPLY SOLDER MASK TO AREAS THAT ARE NOT SOLDERED

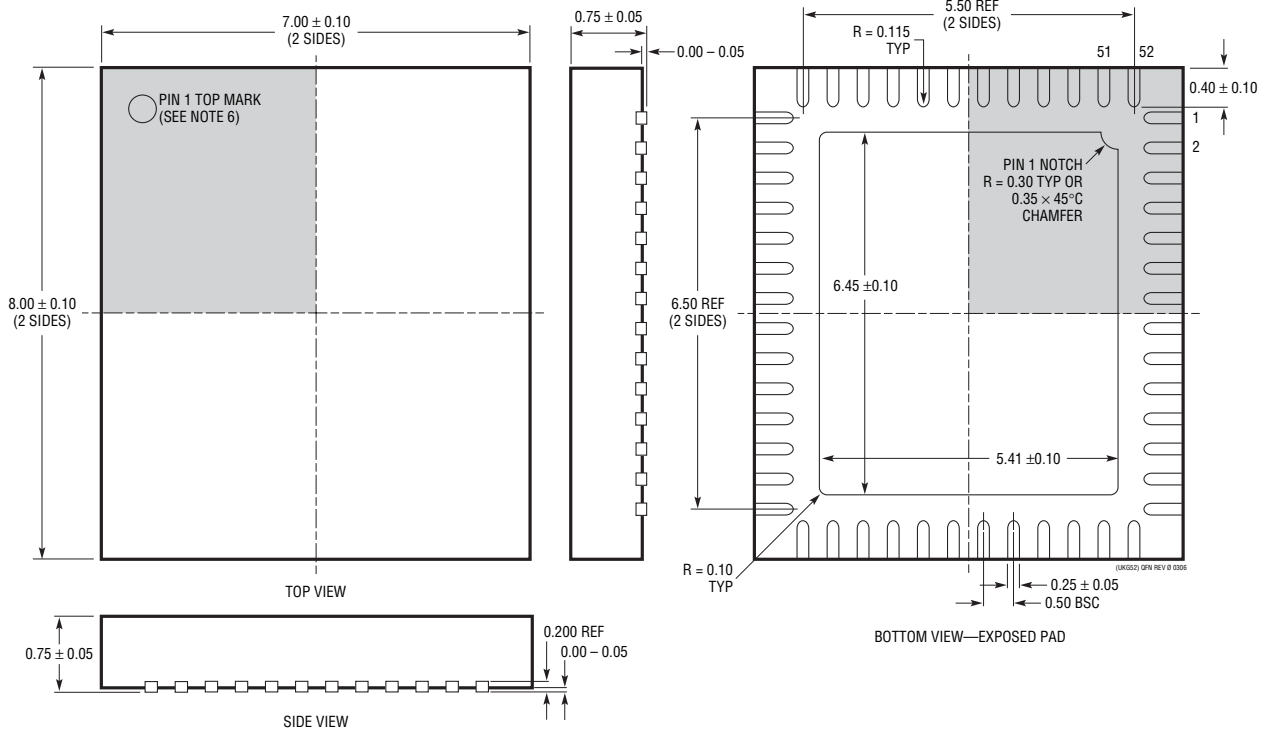

- NOTE:
1. DRAWING IS NOT A JEDEC PACKAGE OUTLINE
 2. DRAWING NOT TO SCALE
 3. ALL DIMENSIONS ARE IN MILLIMETERS
 4. DIMENSIONS OF EXPOSED PAD ON BOTTOM OF PACKAGE DO NOT INCLUDE MOLD FLASH. MOLD FLASH, IF PRESENT, SHALL NOT EXCEED 0.20mm ON ANY SIDE, IF PRESENT
 5. EXPOSED PAD SHALL BE SOLDER PLATED
 6. SHADED AREA IS ONLY A REFERENCE FOR PIN 1 LOCATION ON THE TOP AND BOTTOM OF PACKAGE

TYPICAL APPLICATION

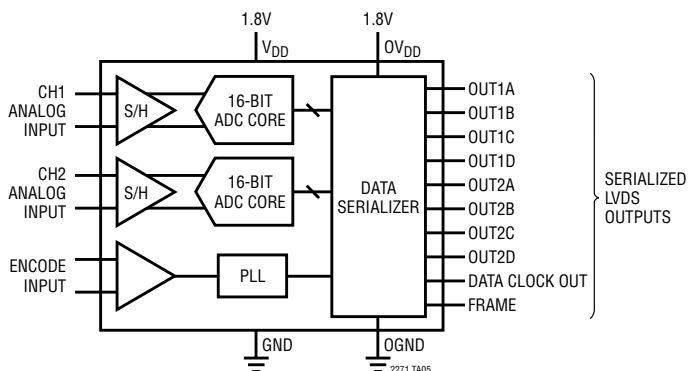

Integral Non-Linearity (INL)

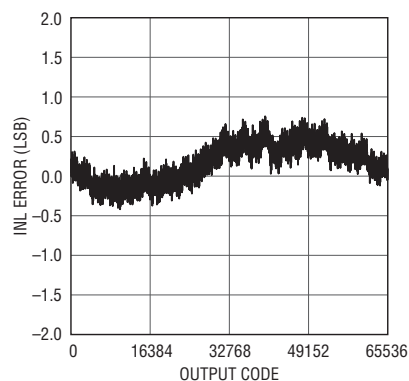

RELATED PARTS

PART NUMBER	DESCRIPTION	COMMENTS
ADCs		
LTC2160	16-Bit 25Msps, 1.8V ADC, Ultralow Power	45mW, 77dB SNR, 90dB SFDR, DDR LVDS/DDR CMOS/CMOS Outputs, 7mm × 7mm QFN-48
LTC2180	16-Bit 25Msps, 1.8V Dual ADC, Ultralow Power	39mW/Ch, 77dB SNR, 90dB SFDR, DDR LVDS/DDR CMOS/CMOS Outputs, 9mm × 9mm QFN-64
LTC2188	16-Bit 20Msps, 1.8V Dual ADC, Ultralow Power	38mW/Ch, 77dB SNR, 90dB SFDR, DDR LVDS/DDR CMOS/CMOS Outputs, 9mm × 9mm QFN-64
LTC2190	16-Bit 25Msps, 1.8V Dual ADC, Ultralow Power	52mW/Ch, 77dB SNR, 90dB SFDR, Serial LVDS Outputs, 7mm × 8mm QFN-52
LTC2202/LTC2203	16-Bit 10Msps/25Msps 3.3V ADCs	140mW/220mW, 81.6dB SNR, 100dB SFDR, CMOS Outputs, 7mm × 7mm QFN-48
PLLs		
LTC6946-X	Ultralow Noise and Spurious Integer-N Synthesizer with Integrated VCO	3.7MHz to 5.7GHz, -226dBc/Hz Normalized In-Band Phase Noise Floor, -157dBc/Hz Wideband Output Phase Noise Floor
LTC6945	Ultralow Noise and Spurious 0.35GHz to 6GHz Integer-N Synthesizer	3.5GHz to 6GHz, -226dBc/Hz Normalized In-Band Phase Noise Floor, -157dBc/Hz Wideband Output Phase Noise Floor
Signal Chain Receivers		
LTM9002	14-Bit, Dual Channel IF/Baseband μModule Receiver	Dual ADC, Dual Amplifiers, Anti-Alias Filters and a Dual Trim DAC in 15mm × 11.25mm LGA
LTM9004	14-Bit, Direct Conversion μModule Receiver	I/Q Demodulator, Baseband Amplifiers, Lowpass Filters Up to 20MHz, Dual 14-Bit 125Msps ADC in 22mm × 15mm LGA
RF Mixers/Demodulators		
LTC5569	300MHz to 4GHz Dual Active Downconverting Mixer	High IIP3: 26.8dBm, 2dB Conversion Gain, Low Power: 3.3V/600mW, Integrated RF Transformer for compact Footprint
LTC5584	30MHz to 1.4GHz Wideband I/Q Demodulator	I/Q Demodulation Bandwidth >530MHz, 31dBm IIP3, IIP2 Adjustable to >80dBm, DC Offset Adjustable to Zero, 45dB Image Rejection
LTC5585	700MHz to 3GHz Wideband I/Q Demodulator	I/Q Demodulation Bandwidth >530MHz, 25.7dBm IIP3, IIP2 Adjustable to >80dBm, DC Offset Adjustable to Zero, 43dB Image Rejection