

LTC3883EUH

Single-Phase, Step-Down DC/DC Controller with Digital Power Management

DESCRIPTION

Demonstration circuit 1778A is a single-output, synchronous buck converter featuring the LTC3883EUH, a single-output current mode controller with digital power management and input current sense capability. There are two versions of the board available:

- DC1778A-A: senses output inductor current across a sense resistor.
- DC1778A-B: senses output inductor current with the inductor DCR.

Either version can be populated with the LTC3883EUH-1, which allows the user to provide bias power to the IC from an external power supply to save on-board LDO power loss.

The output voltage of the board can be programmed from 0.5V to 5V, with output current up to 20A. The factory default setting for the output is 1.8V.

The DC1778A powers up to default settings and produces power based on configuration resistors, or NVM, without the need for any serial bus communication. This allows easy

evaluation of the DC/DC converter aspects of the LTC3883. To fully explore the extensive digital power management features of the part, download the LTpowerPlay™ GUI software onto your PC and use LTC's I²C/SMBus/PMBus dongle DC1613A to connect to the board. LTpowerPlay allows the user to reconfigure the part on-the-fly and store the configuration in EEPROM, view telemetry of voltage, current, temperature and fault status.

GUI DOWNLOAD

The software can be downloaded from:
<http://www.linear.com/ltpowerplay>

For more details and instructions of LTpowerPlay, please refer to the LTpowerPlay for LTC3883 Quick Start Guide.

Design files for this circuit board are available at
<http://www.linear.com/demo>

LT, LT, LTC, LTM, Linear Technology, the Linear logo and Burst Mode are registered trademarks and LTpowerPlay is a trademark of Linear Technology Corporation. All other trademarks are the property of their respective owners.

PERFORMANCE SUMMARY Specifications are at T_A = 25°C

SYMBOL	PARAMETER	CONDITIONS	MIN	TYP	MAX	UNITS
V _{IN}	Input Supply Range		6.5	12	24	V
V _{OUT}	Output Voltage Range	I _{OUT} = 0A to 20A, V _{IN} = 6.5V to 24V	0.5	1.8	5.0	V
V _{OUT_ACC}	Output Voltage Range Accuracy	I _{OUT} = 0A to 20A, V _{IN} = 6.5V to 24V, V _{OUT} = 0.5V to 5.0V	-0.5		0.5	%
I _{OUT}	Output Current Range		0		20	A
f _{SW}	Factory Default Switching			425		kHz
EFF	Peak Efficiency	V _{OUT} = 1.8V, See Figures 6 and 7		91.4		%

QUICK START PROCEDURE

Demonstration circuit 1778A makes it easy to set up to evaluate the performance of the LTC3883. Refer to Figure 3 for proper measurement equipment setup, and follow the procedure below.

NOTE: When measuring the input or output voltage ripple, care must be taken to avoid a long ground lead on the oscilloscope probe. Measure the output voltage ripple by touching the probe tip directly across the C11. See Figure 5 for the proper scope probe technique.

1. Make sure jumpers are in the following positions:

JUMPER	POSITION	FUNCTION
JP1	OFF	Write Protection of LTC3883
JP2	FT3	GPIOB to Fault 3 (of the Connector)
JP3	CTRL0	RUN to Control 0 (of the Connector)
JP5	OFF	EXTVCC_DRV: External V _{CC} for the LTC3883-1
JP6	ON	LED Indicator

2. With power off, connect the input power supply to V_{IN} and GND. Connect active load to the output.
3. Make sure RUN switch (SW1) is OFF.
4. Turn on the power at the input.

NOTE: Make sure that the input voltage does not exceed 24V.

5. Turn on the RUN switch as desired.
6. Check for the correct output voltage. V_{OUT} = 1.8V ± 0.5% (1.791V ~ 1.809V).

NOTE: If there is no output, temporarily disconnect the load to make sure that the load is not set too high.

7. Once the proper output voltages are established, adjust the loads within the operating range and observe the output voltage regulation, ripple voltage, efficiency and other parameters.
8. Connect the dongle and control the output voltages from the GUI. See LTpowerPlay for LTC3883 Quick Start Guide for detail.

CONNECTING A PC TO DC1778A

You can use a PC to reconfigure the power management features of the LTC3883, such as: nominal V_{OUT}, margin set points, OV/UV limits, temperature fault limits, sequencing parameters, the fault log, fault responses, GPIO and other functionality. The DC1613A dongle may be plugged in regardless of whether or not V_{IN} is present.

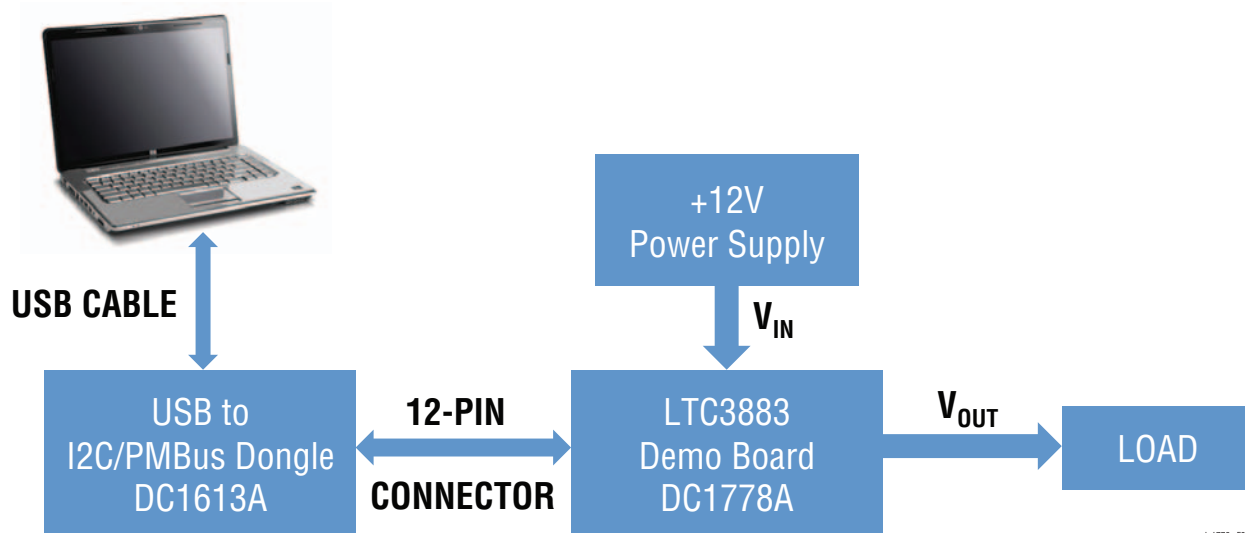

dc1778a F01

Figure 1. Demo Setup with PC

dc1778af

QUICK START PROCEDURE

Plug the dongle into the correct connector. The dongle can be hot plugged.

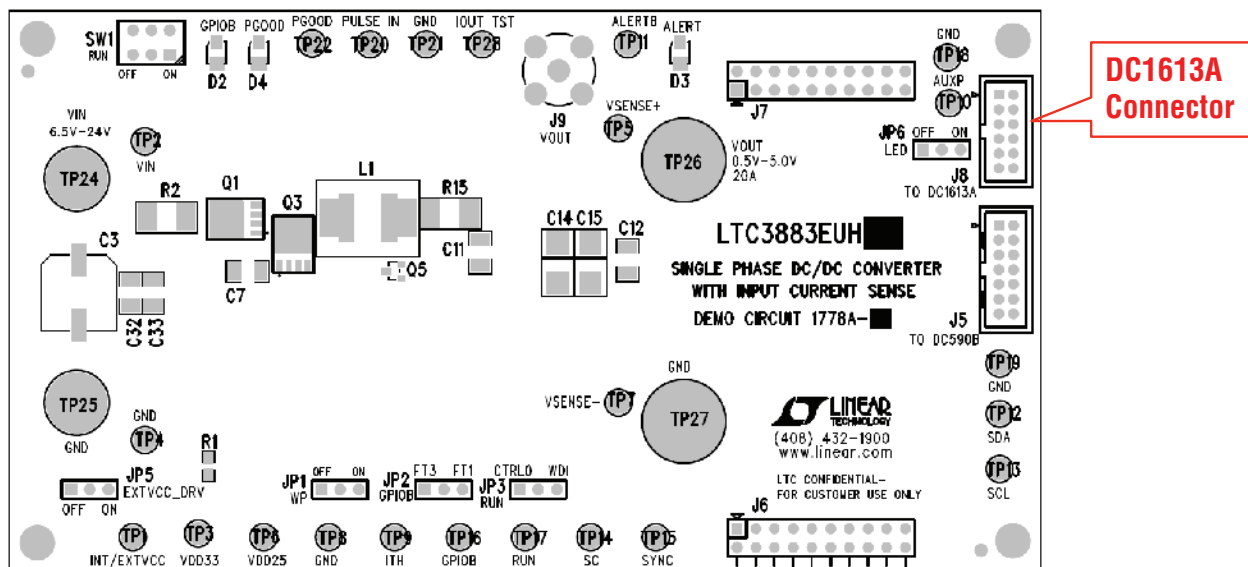

Figure 2. Dongle Connector Locations

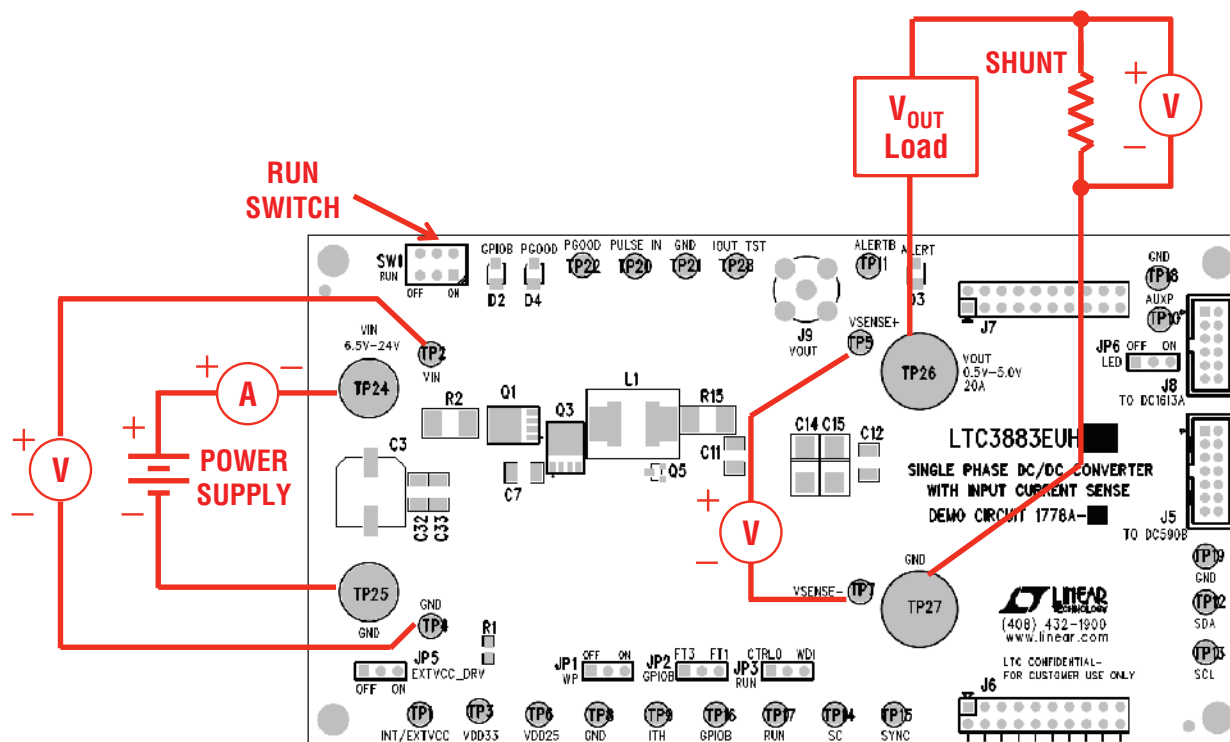

Figure 3. Power Test Setup

QUICK START PROCEDURE

Combining DC1778A with Other Digital Power Demo Boards

The DC1778A may be plugged together in a multiboard array with other LTC digital power boards, using J6 and J7.

Measuring Efficiency (See Figure 4)

To accurately measure efficiency of any configuration, do the following:

- Make sure R52 (bleeder resistor on bottom side of board) is not installed.
- Set JP6 to OFF to disable the regulator that provides power to LEDs.
- Measure V_{IN} across the input ceramic capacitor (C7). Measure V_{OUT} across the output ceramic capacitor (C11).

Evaluating the LTC3883 When V_{IN} Is Below 6V

For applications using an input voltage within 4.5V to 6V, please install R5 to connect V_{IN} directly to INTVCC. Please be aware that in this case V_{IN} cannot exceed 6V, otherwise the chip will be damaged.

Evaluating the LTC3883-1

For applications that require the highest possible efficiency, the LTC3883-1 allows the user to supply the

bias voltage and gate driver current from an external power supply. Connect the external power supply, 4.8V to 5.2V, to the EXTVCC pin. Obtain a DC1778A with an LTC3883-1 installed from your Linear Technology Field Applications Engineer.

To use the on-board LDO to drive INTVCC, make the following modifications to the demo board:

- Set JP5 to ON so that U3 provides the 5V drive to INTVCC. U3 takes the place of the external power supply.
- Install R1.

To accurately measure efficiency of a demo board containing an LTC3883-1:

- Drive INTVCC from an external source through the pin named: INT/EXTVCC.
- Set JP5 to OFF to disable U3.
- Measure V_{IN} across the input ceramic capacitor (C7). Measure V_{OUT} across the output ceramic capacitor (C11).

Measuring Output Ripple Voltage

An accurate ripple measurement may be performed by using the configuration in Figure 5 across C11.

QUICK START PROCEDURE

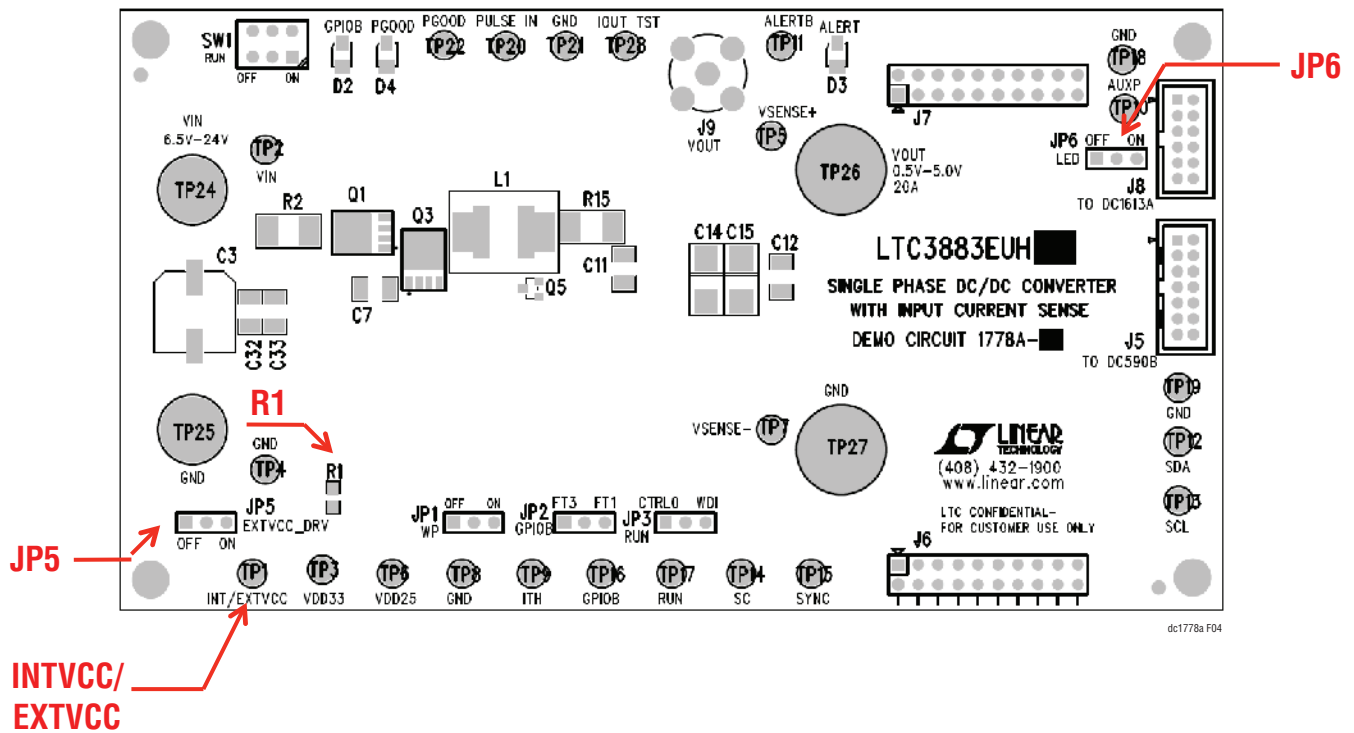

Figure 4. Jumper Locations: JP5, JP6, R1, INTVCC Turret

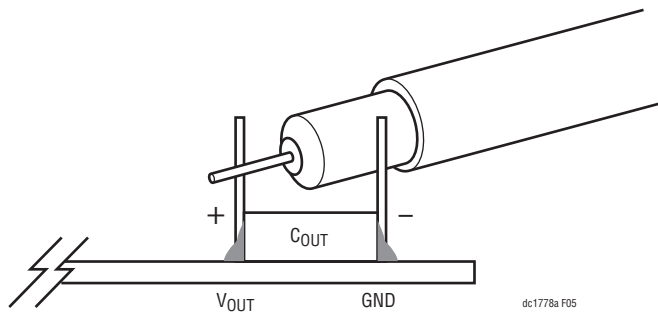

Figure 5. Measuring Output Voltage Ripple

QUICK START PROCEDURE

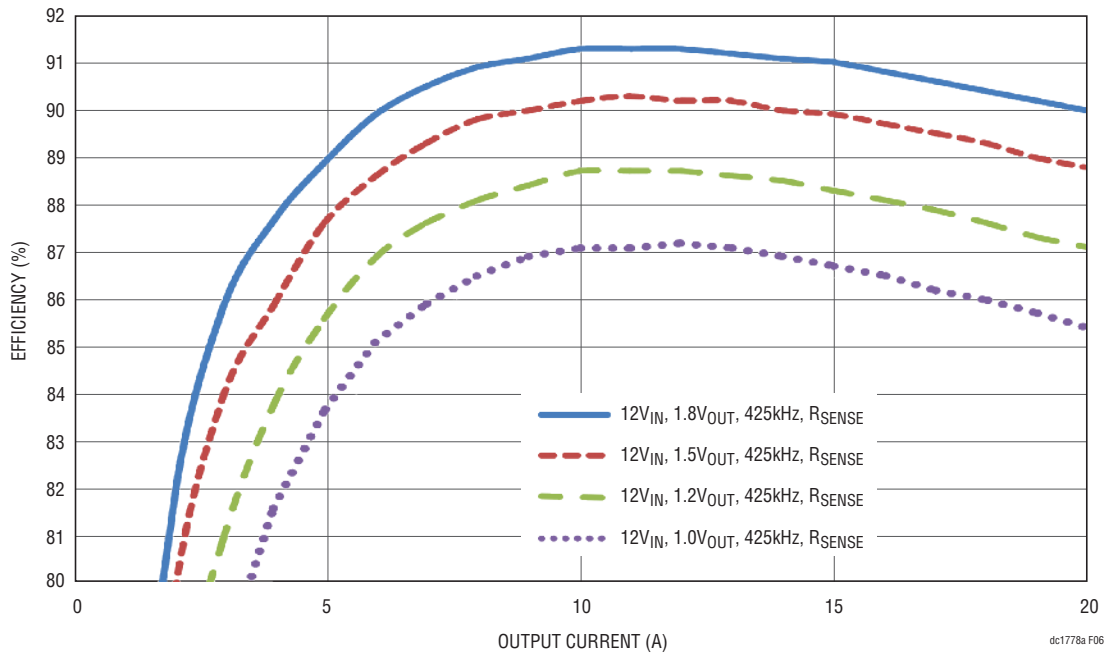

Figure 6. Typical Efficiency Curves, DC1778A-A Sense Resistor Current Sensing, 1.8V_{OUT}, 12V_{IN}, f_{SW} = 425kHz

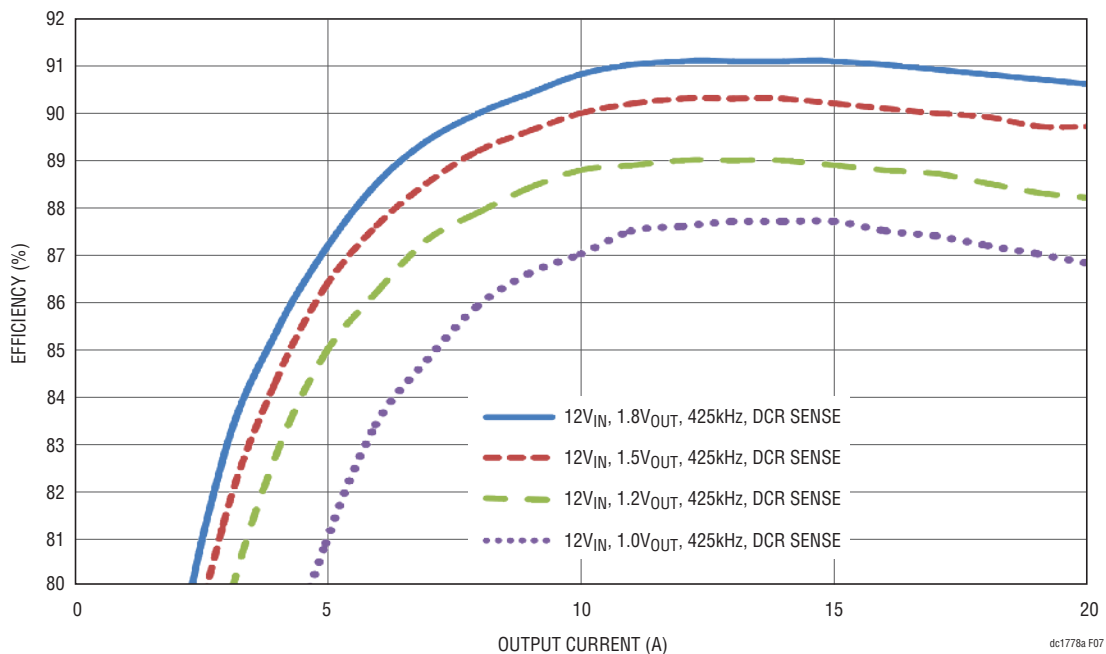

Figure 7. Typical Efficiency Curves, DC1778A-B DCR Current Sensing, 1.8V_{OUT}, 12V_{IN}, f_{SW} = 425kHz

QUICK START PROCEDURE

LTpowerPlay Software GUI

LTpowerPlay is a powerful Windows based development environment that supports Linear Technology digital power ICs with EEPROM, including the LTC3883, LTC2974 and LTC2978. The software supports a variety of different tasks. You can use LTpowerPlay to evaluate Linear Technology ICs by connecting to a demo board system. LTpowerPlay can also be used in an offline mode (with no hardware present) in order to build a multichip configuration file that can be saved and reloaded at a later time. LTpowerPlay provides unprecedented diagnostic and debug features. It becomes a valuable diagnostic tool during board bring-up to program or tweak the power management scheme in

a system, or to diagnose power issues when bringing up rails. LTpowerPlay utilizes the DC1613A USB-to-SMBus controller to communicate with one of many potential targets, including the LTC3880's DC1590B demo system, or a customer board. The software also provides an automatic update feature to keep the software current with the latest set of device drivers and documentation. The LTpowerPlay software can be downloaded from:

<http://linear.com/ltpowerplay>

To access technical support documents for LTC Digital Power Products visit Help. View online help on the LTpowerPlay menu.

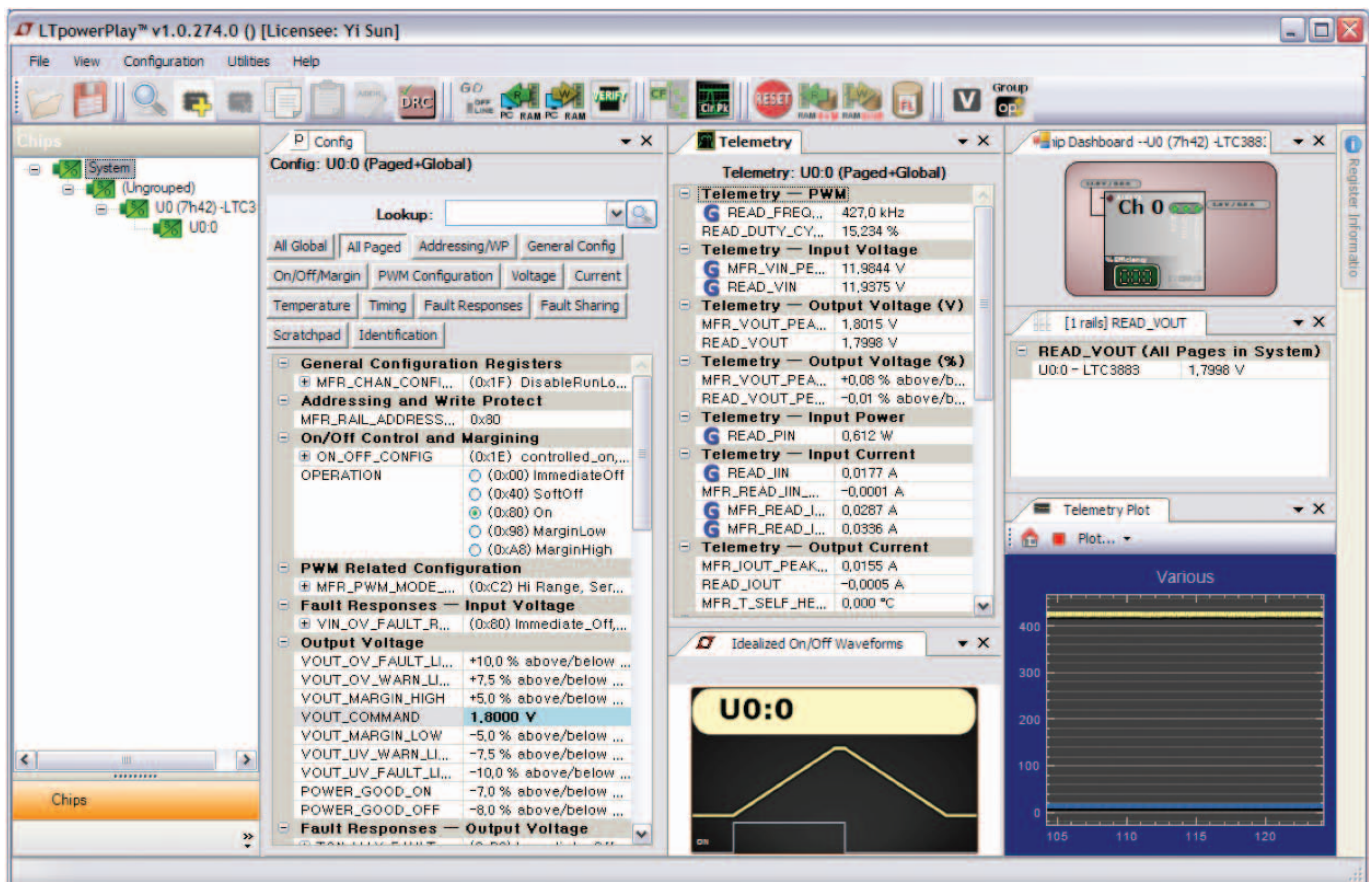

Figure 8. LTpowerPlay Software GUI

GUI QUICK START PROCEDURE

LTpowerPlay Software GUI

The following procedure describes how to use LTpowerPlay to monitor and change the settings of the LTC3883.

1. Download and install the LTPowerPlay GUI:

<http://linear.com/ltpowerplay>

2. Launch the LTpowerPlay GUI.

- a. The GUI should automatically identify the LTC3883. The system tree on the left hand side should look like this:

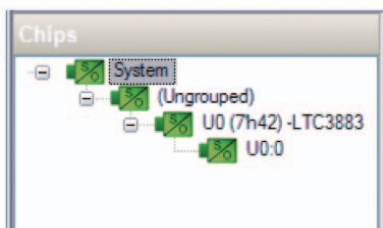

- b. A green message box shows for a few seconds in the lower left hand corner, confirming that the LTC3883 is communicating:

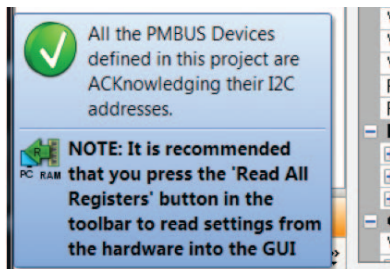

- c. In the tool bar, click the “R” (RAM to PC) icon to read the RAM from the LTC3883. This reads the configuration from the RAM of LTC3883 and loads it into the GUI.



- d. To change the output voltage to a different value, like 1.5V: In the Config tab, type 1.5 in the VOUT_COMMAND box, like this:

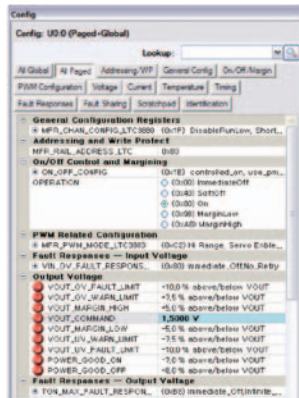

- Then, click the “W” (PC to RAM) icon to write these register values to the LTC3883. After finishing this step, you will see the output voltage will change to 1.5V.



- If the write is successful, this message appears:

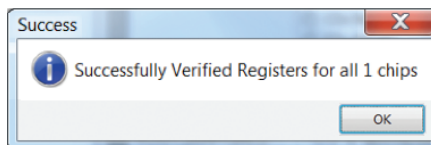

- e. To save the changes into the NVM: In the tool bar, click the “RAM to NVM” button:



- f. Save the demo board configuration to a (*.proj) file by clicking the Save icon. Name it whatever you want.

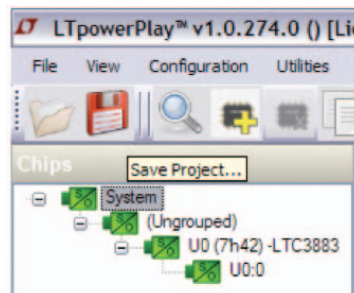

GUI QUICK START PROCEDURE

Loading a LTC3883 Configuration (*.proj) File with the GUI

- In the upper left hand corner of the GUI: File>Open>browse to your *.proj file. This will load the file into the GUI.
- Click the “Go On Line” button to link the GUI to the existing LTC3883, as this:



- Click on the “W” (PC to RAM) button. This loads the configuration into LTC3883 RAM.
- Then, you can save the configuration to the EEPROM. Please see previous step f for details.

PARTS LIST DC1778A-A

ITEM	QTY	REFERENCE	PART DESCRIPTION	MANUFACTURER/PART NUMBER
Required Circuit Components				
1	5	C2, C10, C18, C6, C34	CAP., X7R, 0.1µF, 25V, 10%, 0603	TDK, C1608X7R1E104K
2	1	C17	CAP., X5R, 1000pF, 25V, 10%, 0603	AVX, 06033C102KAT4A
3	3	C4, C5, C8	CAP., X5R, 1µF, 25V, 10%, 0603	AVX, 06033D105KAT2A
4	4	C7, C9, C32, C33	CAP., X5R, 10µF, 35V, 10%, 1210	AVX, 1210DD106KAT2A
5	1	C1	CAP., X5R, 4.7µF, 10V, 0603	AVX, 0603ZD475KAT2A
6	3	C11, C12, C13	CAP., X5R, 100µF, 6.3V, 1210	AVX, 12106D107KAT2A
7	2	C14, C15	CAP, POSCAP, 330µF, 6V, D3L	SANYO, 6TPF330M9L
8	1	C19	CAP., X7R, 4.7nF, 25V, 0603	AVX, 06033C472KAT2A
9	1	C20	CAP., X7R, 100pF, 5%, 50V, 0603	AVX, 06035C101JAT2A
10	1	C3	CAP, OS-CON, 150µF, 35V	SUN ELECT., 35HVP150M
11	1	C21	CAP., X7R, 0.01µF, 10%, 50V, 0603	AVX, 06035C103KAT2A
12	2	C30, C31	CAP., X5R, 0.01µF, 50V, 10%, 0603	AVX, 06035D103KAT2A
13	1	D1	DIODE, SCHOTTKY, SOD-323	CENTRAL, CMDSH-3TR
14	1	Q1	MOSFET, N-CH, 30V, 80A, TDSO8	INFINEON, BSC050N03LS G
15	1	Q3	MOSFET, N-CH, 30V, 100A, TDSO8	INFINEON, BSC011N03LSI
16	1	Q5	TRANS GP, SS, PNP, 40V, SOT-23	ON SEMI, MMBT3906LT1G
17	1	Q10	MOSFET, P-CH, 20V, 0.58A, SOT-23	VISHAY, TP0101K-T1-E3
18	1	R23	RES., CHIP, 90.9k, 1%, 0603	NIC, NRC06F2492TRF
19	1	R28	RES., CHIP, 4.32k, 1%, 0603	VISHAY, CRCW06034K32FKEA
20	1	R2	RES., CHIP, 0.005, 1%, 1W, 2512	PANASONIC, ERJM1WSF5M0U
21	1	R15	RES., 0.002, 1%, 2512	VISHAY, WSL25122L000FEA
22	4	R3, R4, R21, R27	RES., CHIP, 100, 1%, 0603	VISHAY, CRCW0603100RFKEA
23	5	R14, R16, R19, R20, R22	RES., CHIP, 0, 0603	NIC, NRC06FZ0TRF
24	1	R6	RES., CHIP, 4.99k, 1%, 0603	VISHAY, CRCW06034K99FKEA
25	3	R7, R12, R13	RES., CHIP, 1k, 1%, 0603	VISHAY, CRCW06031K00FKEA
26	6	R8, R9, R10, R11, R44, R61	RES., CHIP, 10k, 1%, 0603	NIC, NRC06F1002TRF
27	1	R32	RES., CHIP, 4.87k, 1%, 0603	VISHAY, CRCW06034K87FKEA

DEMO MANUAL DC1778A

PARTS LIST DC1778A-A

ITEM	QTY	REFERENCE	PART DESCRIPTION	MANUFACTURER/PART NUMBER
28	1	R45	RES., CHIP, 10, 5%, 0603	VISHAY, CRCW060310R0JKEA
29	2	R51, R60	RES., CHIP, 200, 1%, 0603	VISHAY, CRCW0603200RFKEA
30	1	R54	RES., CHIP, 0.05, 1%, 2010	VISHAY, WSL2010R0500FEA
31	1	R55	RES., CHIP, 127, 1%, 0603	VISHAY, CRCW0603127RFKEA
32	2	R56, R57	RES., CHIP, 100k, 1%, 0603	VISHAY, CRCW0603100KFKEA
33	1	R62	RES., CHIP, 15.8k, 1%, 0603	VISHAY, CRCW060315K8FKEA
34	1	R58	RES., CHIP, 3, 1%, 0603	VISHAY, CRCW06033R00FKEA
35	1	U1	IC, LTC3883EUH QFN 6mm x 6mm	LINEAR TECHNOLOGY, LTC3883EUH#PBF
36	1	L1	INDUCTOR, 0.4μH	VITEC, 59PR9875

Additional Demo Board Circuit Components

1	1	C22	CAP., X7R, 0.1μF, 25V, 10%, 0603	TDK, C1608X7R1E104K
2	1	C29	CAP., X5R, 10μF, 25V, 10%, 1206	MURATA, GRM31CR61E106KA12L
3	2	C26, C27	CAP., X7R, 1μF, 25V, 10%, 1206	AVX, 12063C105KAJ2A
4	1	C25	CAP., X5R, 4.7μF, 10V, 0603	AVX, 0603ZD475KAT2A
5	0	C23, C28	CAP, POSCAP, 330μF, 6.3V, D3L	
6	0	C16	CAP., 0603	
7	1	C24	CAP., X5R, 0.22μF, 25V, 0805	AVX, 08053D224KAT2A
8	2	D2, D4	LED GREEN, S-GW TYPE SMD	PANASONIC, LN1371SGTRP
9	1	D3	LED RED, S-TYPE GULL WING SMD	PANASONIC, LN1271RTR
10	1	Q6	MOSFET SPEED, SRS, 30V, 30A, LPAK	RENESAS, RJK0305DPB-00#J0
11	0	Q2, Q4	MOSFET, N-CH, 30V, TDSO8	
12	1	Q7	MOSFET P-CH, 20V, 0.58A, SOT-23	VISHAY, TP0101K-T1-E3
13	2	Q8, Q9	MOSFET N-CH, 60V, 115mA, SOT-23	FAIRCHILD, 2N7002A
14	0	R1, R35, R36, R37, R38	RES., CHIP, 0805	
15	0	R5, R17, R18, R24-R26, R29-R31, R41, R46, R47, R59	RES., CHIP, 0603	
16	4	R33, R34, R40, R42	RES., CHIP, 0, 0603	NIC, NRC06FZ0TRF
17	3	R48, R49, R50	RES., CHIP, 4.99k, 1%, 0603	VISHAY, CRCW06034K99FKEA
18	1	R53	RES., CHIP, 10k, 1%, 0603	NIC, NRC06F1002TRF
19	0	R52	RES., CHIP, 30, 1%, 1W 2512	
20	1	U2	IC, 24LC025-I/ST, SOIC	MICROCHIP, 24LC025-I/ST
21	1	U3	IC, LT1129CS8-5, S8 PACKAGE	LINEAR TECHNOLOGY, LT1129CS8-5
22	1	U4	IC, LT1129CS8-3.3, S8 PACKAGE	LINEAR TECHNOLOGY, LT1129CS8-3.3

Hardware: For Demo Board Only

1	5	JP1-JP3, JP5, JP6	0.1" SINGLE ROW HEADER, 3 PIN	SAMTEC, TSW-103-07-L-S
2	5	JP1-JP3, JP5, JP6	SHUNT, 0.1" BLK	SAMTEC, SNT-100-BK-G
3	2	TP24, TP25	JACK, BANANA	KEYSTONE, 575-4
4	2	TP26, TP27	STUD, TEST PIN	PEM, KFH-032-10
5	1	J6	PIN HEADER, 20 DUAL ROW RA	MILL-MAX, 802-40-020-20-0001
6	1	J7	CONN.SOCKET, 20 DUAL ROW RA	MILL-MAX, 803-93-020-20-001
7	0	J5	HEADER, 14POS, 2mm, VERT GOLD	MOLEX, 87831-1420

PARTS LIST DC1778A-A

ITEM	QTY	REFERENCE	PART DESCRIPTION	MANUFACTURER/PART NUMBER
8	1	J8	CONN, HEADER, 12POS, 2mm, STR DL PCB	FCI, 98414-G06-12ULF
9	2	J9	CONN, BNC, 5 PINS	CONNEX, 112404
10	23	TP1-TP22, TP28	TESTPOINT, TURRET, 0.062"	MILL-MAX, 2308-2-00-80-00-00-07-0
11	1	SW1	CONNECTOR, SUB MINIATURE SLIDE SWITCHES	C&K, JS202011CQN

PARTS LIST DC1778A-B

ITEM	QTY	REFERENCE	PART DESCRIPTION	MANUFACTURER/PART NUMBER
Required Circuit Components				
1	5	C2, C10, C18, C6, C34	CAP., X7R, 0.1µF, 25V, 10%, 0603	TDK, C1608X7R1E104K
2	1	C17	CAP., X5R, 0.22µF, 25V, 10%, 0603	TDK, C1608X7R1E224K
3	4	C4, C5, C8, C16	CAP., X5R, 1µF, 25V, 10%, 0603	AVX, 06033D105KAT2A
4	4	C7, C9, C32, C33	CAP., X5R, 10µF, 35V, 10%, 1210	AVX, 1210DD106KAT2A
5	1	C1	CAP., X5R, 4.7µF, 10V, 0603	AVX, 0603ZD475KAT2A
6	3	C11, C12, C13	CAP., X5R, 100µF, 6.3V, 1210	AVX, 12106D107KAT2A
7	2	C14, C15	CAP, POSCAP, 330µF, 6V, D3L	SANYO, 6TPF330M9L
8	1	C19	CAP., X7R, 4.7nF, 25V, 0603	AVX, 06033C472KAT2A
9	1	C20	CAP., X7R, 100pF, 5%, 50V, 0603	AVX, 06035C101JAT2A
10	1	C3	CAP, OS-CON, 150µF, 35V	SUN ELECT., 35HVP150M
11	1	C21	CAP., X7R, 0.01µF, 10%, 50V, 0603	AVX, 06035C103KAT2A
12	2	C30, C31	CAP., X5R, 0.01µF, 50V, 10%, 0603	AVX, 06035D103KAT2A
13	1	D1	DIODE, SCHOTTKY, SOD-323	CENTRAL, CMDSH-3TR
14	1	Q1	MOSFET, N-CH, 30V, 80A, TDSON-8	INFINEON, BSC050N03LS G
15	1	Q3	MOSFET, N-CH, 30V, 100A, TDSON-8	INFINEON, BSC011N03LSI
16	1	Q5	TRANS GP SS, PNP, 40V, SOT-23	ON SEMI, MMBT3906LT1G
17	1	Q10	MOSFET P-CH, 20V, 0.58A, SOT-23	VISHAY, TP0101K-T1-E3
18	1	R23	RES., CHIP, 90.9k, 1%, 0603	NIC, NRC06F2492TRF
19	1	R28	RES., CHIP, 4.32k, 1%, 0603	VISHAY, CRCW06034K32FKEA
20	1	R2	RES., CHIP, 0.005, 1%, 1W 2512	PANASONIC, ERJM1WSF5M0U
21	1	R15	RES., 0 1%, 1W, 2512	TEPRO, RN5326
22	4	R3, R4	RES., CHIP, 100, 1%, 0603	VISHAY, CRCW0603100RFKEA
23	5	R14, R16, R18, R21, R22	RES., CHIP, 0, 0603	NIC, NRC06FZ0TRF
24	1	R6	RES., CHIP, 4.99k, 1%, 0603	VISHAY, CRCW06034K99FKEA
25	3	R7, R12, R13	RES., CHIP, 1k, 1%, 0603	VISHAY, CRCW06031K00FKEA
26	2	R17, R27	RES., CHIP, 1.4k, 1%, 0603	VISHAY, CRCW06031K40FKEA
27	6	R8, R9, R10, R11, R44, R61	RES., CHIP, 10k, 1%, 0603	NIC, NRC06F1002TRF
28	1	R32	RES., CHIP, 4.87k, 1%, 0603	VISHAY, CRCW06034K87FKEA
29	1	R45	RES., CHIP, 10, 5%, 0603	VISHAY, CRCW060310R0JKEA
30	2	R51, R60	RES., CHIP, 200, 1%, 0603	VISHAY, CRCW0603200RFKEA

DEMO MANUAL DC1778A

PARTS LIST DC1778A-B

ITEM	QTY	REFERENCE	PART DESCRIPTION	MANUFACTURER/PART NUMBER
31	1	R54	RES., CHIP, 0.05, 1%, 2010	VISHAY, WSL2010R0500FEA
32	1	R55	RES., CHIP, 127, 1%, 0603	VISHAY, CRCW0603127RFKEA
33	2	R56, R57	RES., CHIP, 100k, 1%, 0603	VISHAY, CRCW0603100KFKEA
34	1	R62	RES., CHIP, 15.8k, 1%, 0603	VISHAY, CRCW060315K8FKEA
35	1	R58	RES., CHIP, 3, 1%, 0603	VISHAY, CRCW06033R00FKEA
36	1	U1	IC, LTC3883EUH QFN 6mm x 6mm	LINEAR TECHNOLOGY, LTC3883EUH#PBF
37	1	L1	INDUCTOR, 0.56μH	COILCRAFT., XAL7070-551ME

Additional Demo Board Circuit Components

1	1	C22	CAP., X7R, 0.1μF, 25V, 10%, 0603	TDK, C1608X7R1E104K
2	1	C29	CAP., X5R, 10μF, 25V, 10%, 1206	MURATA, GRM31CR61E106KA12L
3	2	C26, C27	CAP., X7R, 1μF, 25V, 10%, 1206	AVX, 12063C105KAJ2A
4	1	C25	CAP., X5R, 4.7μF, 10V, 0603	AVX, 0603ZD475KAT2A
5	0	C23, C28	CAP, POSCAP, 330μF, 6.3V, D3L	
6	1	C24	CAP., X5R, 0.22μF, 25V, 0805	AVX, 08053D224KAT2A
7	2	D2, D4	LED GREEN, S-GW TYPE, SMD	PANASONIC, LN1371SGTRP
8	1	D3	LED RED, S-TYPE GULL WING, SMD	PANASONIC, LN1271RTR
9	1	Q6	MOSFET SPEED, SRS, 30V, 30A, LFPK	RENESAS, RJK0305DPB-00#J0
10	0	Q2, Q4	MOSFET, N-CH, 30V, TDSO8	
11	1	Q7	MOSFET P-CH, 20V, 0.58A, SOT-23	VISHAY, TP0101K-T1-E3
12	2	Q8, Q9	MOSFET N-CH, 60V, 115mA, SOT-23	FAIRCHILD, 2N7002A
13	0	R1, R35, R36, R37, R38	RES., CHIP, 0805	
14	0	R5, R19, R20, R24-R26, R29-R31, R41, R46, R47, R59	RES., CHIP, 0603	
15	4	R33, R34, R40, R42	RES., CHIP, 0, 0603	NIC, NRC06FZ0TRF
16	3	R48, R49, R50	RES., CHIP, 4.99k, 1%, 0603	VISHAY, CRCW06034K99FKEA
17	1	R53	RES., CHIP, 10k, 1%, 0603	NIC, NRC06F1002TRF
18	0	R52	RES., CHIP, 30, 1%, 1W 2512	
19	1	U2	IC, 24LC025-I/ST, SOIC	MICROCHIP, 24LC025-I/ST
20	1	U3	IC, LT1129CS8-5, S8 PACKAGE	LINEAR TECHNOLOGY, LT1129CS8-5
21	1	U4	IC, LT1129CS8-3.3 S8 PACKAGE	LINEAR TECHNOLOGY, LT1129CS8-3.3

Hardware: For Demo Board Only

1	5	JP1-JP3, JP5, JP6	0.1" SINGLE ROW HEADER, 3 PIN	SAMTEC, TSW-103-07-L-S
2	5	JP1-JP3, JP5, JP6	SHUNT, 0.1" BLK	SAMTEC, SNT-100-BK-G
3	2	TP24, TP25	JACK, BANANA	KEYSTONE, 575-4
4	2	TP26, TP27	STUD, TEST PIN	PEM, KFH-032-10
5	1	J6	PIN HEADER, 20 DUAL ROW, RA	MILL-MAX, 802-40-020-20-0001
6	1	J7	CONN., SOCKET, 20 DUAL ROW, RA	MILL-MAX, 803-93-020-20-001
7	0	J5	HEADER, 14POS, 2mm, VERT GOLD	MOLEX, 87831-1420
8	1	J8	CONN., HEADER, 12POS, 2mm, STR DL PCB	FCI, 98414-G06-12ULF
9	2	J9	CONN., BNC, 5 PINS	CONNEX, 112404
10	23	TP1-TP22, TP28	TEST POINT, TURRET, 0.062"	MILL-MAX, 2308-2-00-80-00-00-07-0
11	1	SW1	CONNECTOR, SUB MINIATURE SLIDE SWITCHES	C&K, JS202011CQN

dc1778af

SCHEMATIC DIAGRAM

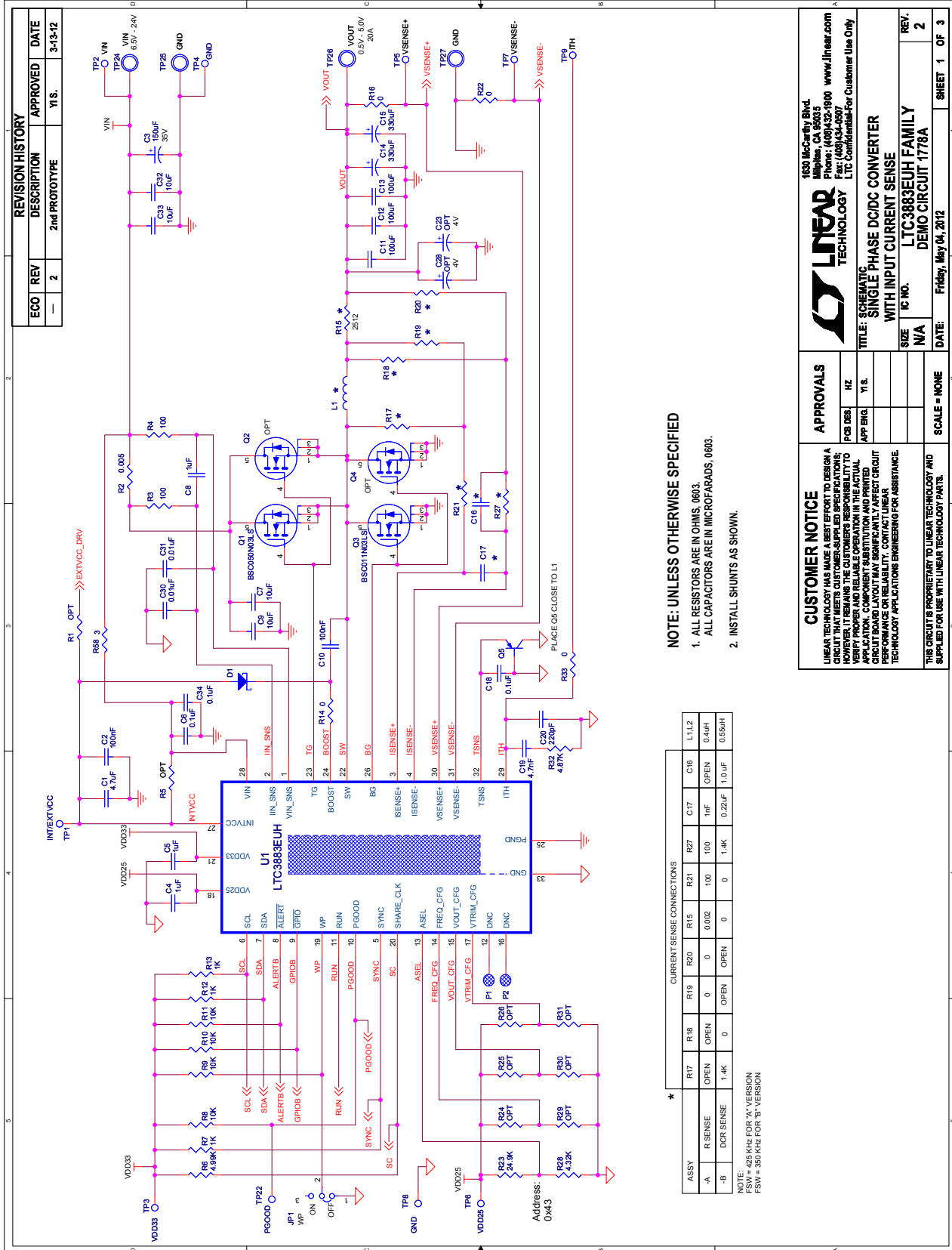
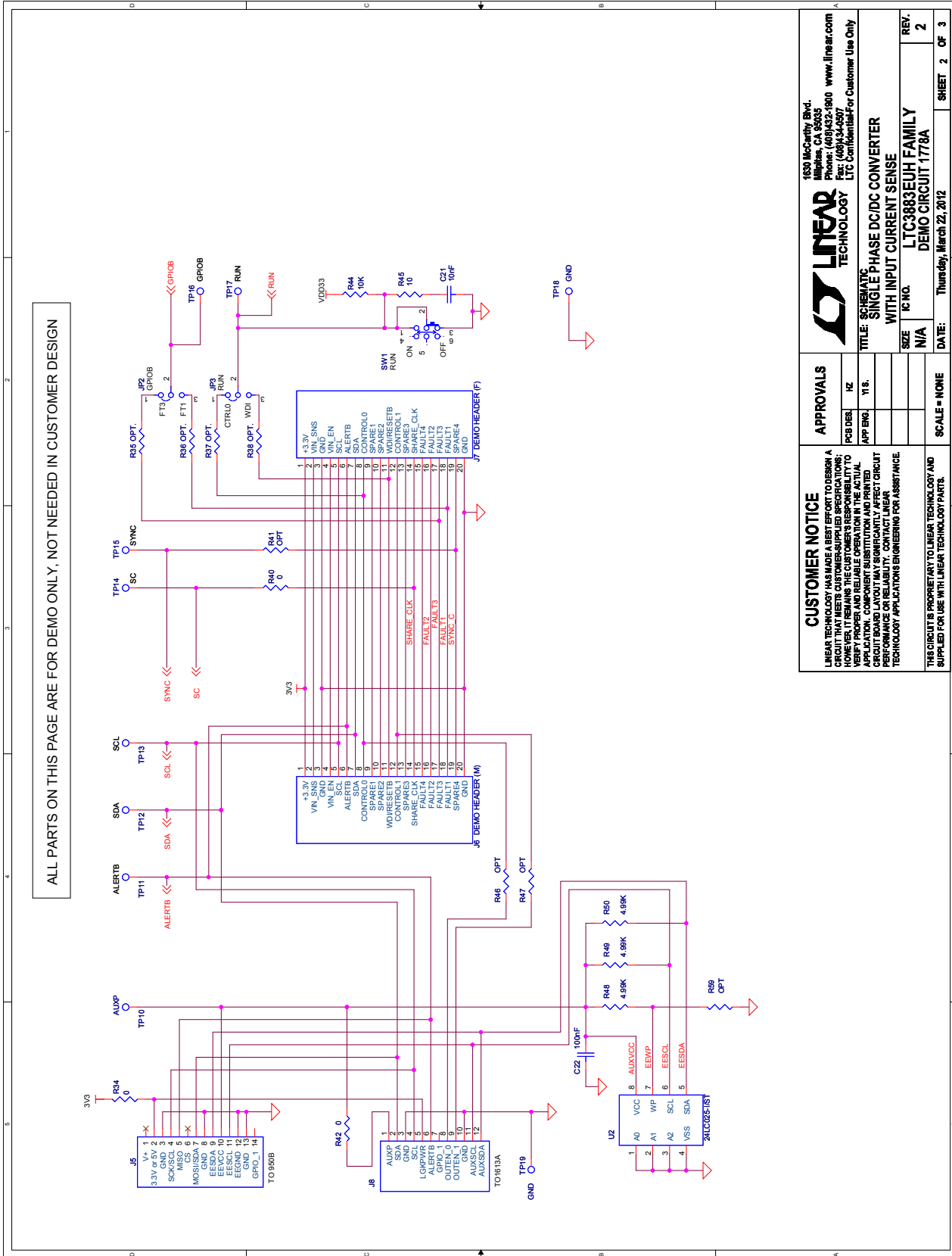

Figure 9. Demo Circuit 1778A Single-Phase DC/DC Converter with Input Current Sense

SCHEMATIC DIAGRAM



APPROVALS		1630 McCarthy Blvd. Milpitas, CA 95035 Phone: (408)432-1800 www.linear.com Fax: (408)344-4907 LTC Confidential-For Customer Use Only	
PCB USE	IC	LINEAR TECHNOLOGY	
APP ENG.	Y1 S.		
CUSTOMER NOTICE		TITLE: SCHEMATIC SINGLE PHASE DC/DC CONVERTER WITH INPUT CURRENT SENSE SIZE: IC NO. LTC3883EUH FAMILY REV.: 2 DATE: Thursday, March 22, 2012 SCALE: NONE SHEET: 2 OF 3	
LINEAR TECHNOLOGY HAS MADE A BEST EFFORT TO DESIGN A CIRCUIT THAT MEETS CUSTOMER-SUPPLIED SPECIFICATIONS. HOWEVER, CUSTOMERS ARE RESPONSIBLE FOR VERIFYING THE PROPER AND RELIABLE OPERATION IN THE ACTUAL APPLICATION. COMPONENT SUBSTITUTION AND PRINTED CIRCUIT BOARD LAYOUT MAY SIGNIFICANTLY AFFECT CIRCUIT PERFORMANCE OR RELIABILITY. CONTACT LINEAR TECHNOLOGY APPLICATIONS ENGINEERING FOR ASSISTANCE.			
THIS CIRCUIT IS PROPRIETARY TO LINEAR TECHNOLOGY AND SUPPLIED FOR USE WITH LINEAR TECHNOLOGY PARTS.			

Figure 10. Demo Circuit 1778A Single-Phase DC/DC Converter with Input Current Sense

SCHEMATIC DIAGRAM

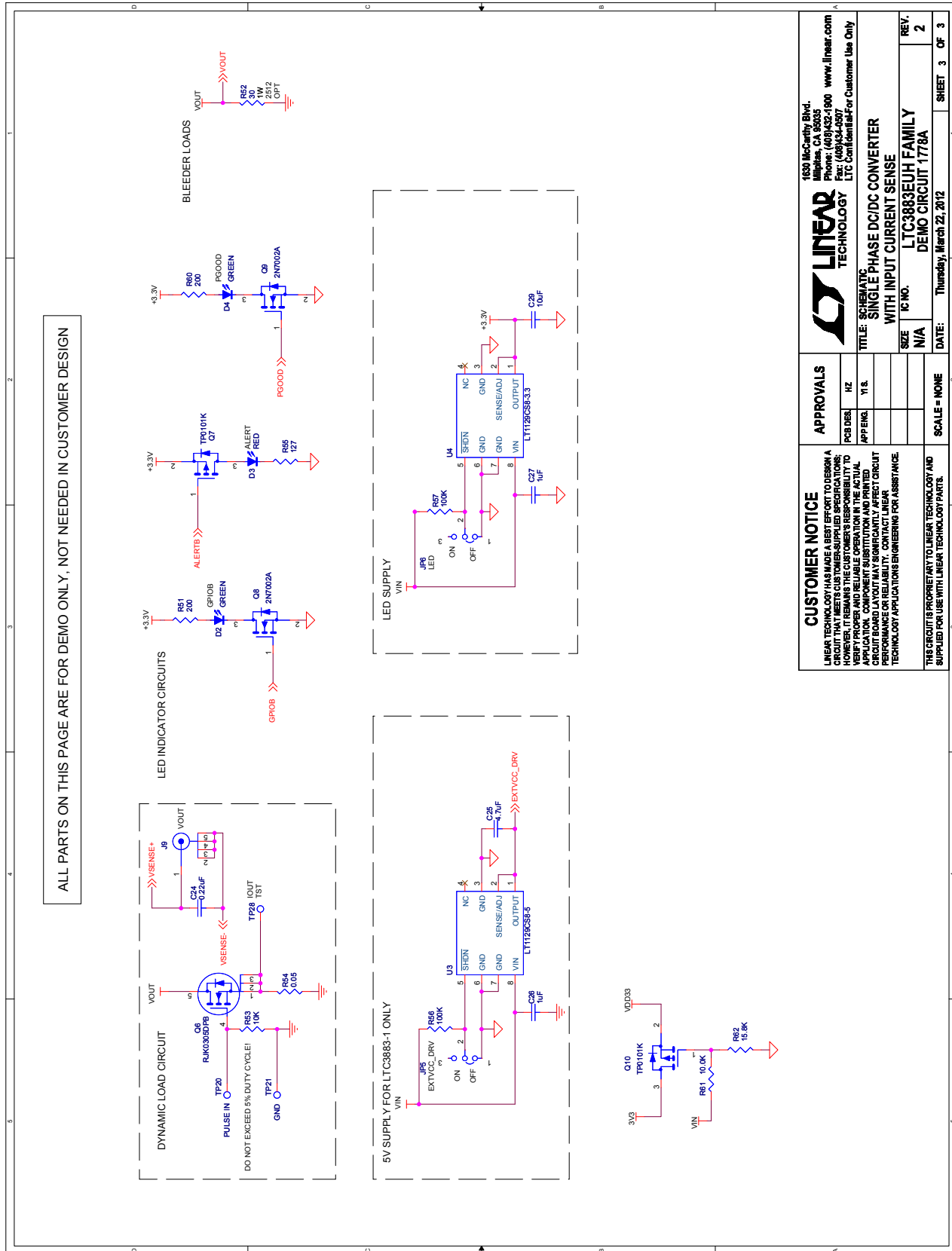

Figure 11. Demo Circuit 1778A Single-Phase DC/DC Converter with Input Current Sense

DEMO MANUAL DC1778A

DEMONSTRATION BOARD IMPORTANT NOTICE

Linear Technology Corporation (LTC) provides the enclosed product(s) under the following **AS IS** conditions:

This demonstration board (DEMO BOARD) kit being sold or provided by Linear Technology is intended for use for **ENGINEERING DEVELOPMENT OR EVALUATION PURPOSES ONLY** and is not provided by LTC for commercial use. As such, the DEMO BOARD herein may not be complete in terms of required design-, marketing-, and/or manufacturing-related protective considerations, including but not limited to product safety measures typically found in finished commercial goods. As a prototype, this product does not fall within the scope of the European Union directive on electromagnetic compatibility and therefore may or may not meet the technical requirements of the directive, or other regulations.

If this evaluation kit does not meet the specifications recited in the DEMO BOARD manual the kit may be returned within 30 days from the date of delivery for a full refund. **THE FOREGOING WARRANTY IS THE EXCLUSIVE WARRANTY MADE BY THE SELLER TO BUYER AND IS IN LIEU OF ALL OTHER WARRANTIES, EXPRESSED, IMPLIED, OR STATUTORY, INCLUDING ANY WARRANTY OF MERCHANTABILITY OR FITNESS FOR ANY PARTICULAR PURPOSE. EXCEPT TO THE EXTENT OF THIS INDEMNITY, NEITHER PARTY SHALL BE LIABLE TO THE OTHER FOR ANY INDIRECT, SPECIAL, INCIDENTAL, OR CONSEQUENTIAL DAMAGES.**

The user assumes all responsibility and liability for proper and safe handling of the goods. Further, the user releases LTC from all claims arising from the handling or use of the goods. Due to the open construction of the product, it is the user's responsibility to take any and all appropriate precautions with regard to electrostatic discharge. Also be aware that the products herein may not be regulatory compliant or agency certified (FCC, UL, CE, etc.).

No License is granted under any patent right or other intellectual property whatsoever. **LTC assumes no liability for applications assistance, customer product design, software performance, or infringement of patents or any other intellectual property rights of any kind.**

LTC currently services a variety of customers for products around the world, and therefore this transaction **is not exclusive**.

Please read the DEMO BOARD manual prior to handling the product. Persons handling this product must have electronics training and observe good laboratory practice standards. **Common sense is encouraged.**

This notice contains important safety information about temperatures and voltages. For further safety concerns, please contact a LTC application engineer.

Mailing Address:

Linear Technology
1630 McCarthy Blvd.
Milpitas, CA 95035

Copyright © 2004, Linear Technology Corporation