

Constant Frequency Current Mode Flyback DC/DC Controller in ThinSOT

August 2003

FEATURES

- V_{IN} and V_{OUT} Limited Only by External Components
- Adjustable Slope Compensation
- Internal Soft-Start
- Constant Frequency 200kHz Operation
- $\pm 1.5\%$ Reference Accuracy
- Current Mode Operation for Excellent Line and Load Transient Response
- No Minimum Load Requirement
- Low Quiescent Current: 240 μ A
- Low Profile (1mm) SOT-23 Package

APPLICATIONS

- Telecom Power Supplies
- 42V and 12V Automotive Power Supplies
- Auxiliary/Housekeeping Power Supplies
- Power Over Ethernet

LT, LTC and LT are registered trademarks of Linear Technology Corporation.
ThinSOT is a trademark of Linear Technology Corporation.

DESCRIPTION

The LTC[®]3803 is a constant frequency current mode flyback controller optimized for driving 6V-rated N-channel MOSFETs in high input voltage applications. Constant frequency operation is maintained down to very light loads, resulting in less low frequency noise generation over a wide range of load currents. Slope compensation can be programmed with an external resistor.

The LTC3803 provides $\pm 1.5\%$ output voltage accuracy and consumes only 240 μ A of quiescent current. Ground-referenced current sensing allows LTC3803-based converters to accept input supplies beyond the LTC3803's absolute maximum V_{CC} . A micropower hysteretic start-up feature allows efficient operation at high input voltages. For simplicity, the LTC3803 can also be powered from a high V_{IN} through a resistor, due to its internal 9.4V shunt regulator. An internal undervoltage lockout shuts down the LTC3803 when the input voltage falls below 4.6V, guaranteeing at least 4.6V of gate drive to the external MOSFET.

The LTC3803 is available in a low profile (1mm) 6-lead SOT-23 (ThinSOT[™]) package.

TYPICAL APPLICATION

5V Output Nonisolated Telecom Housekeeping Power Supply

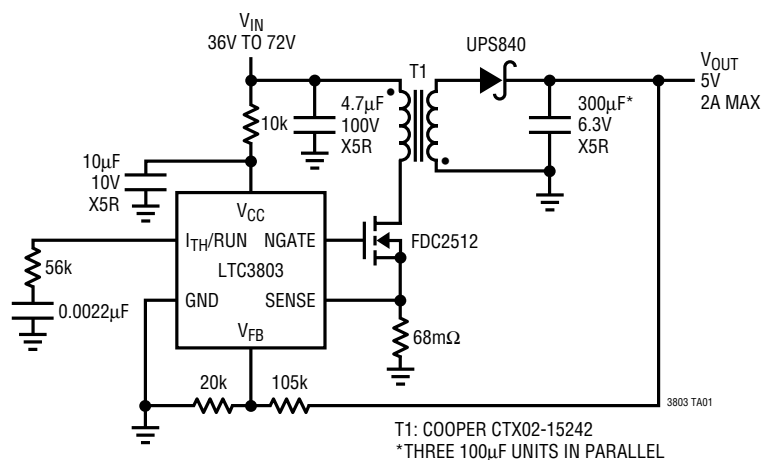

Efficiency vs Load Current

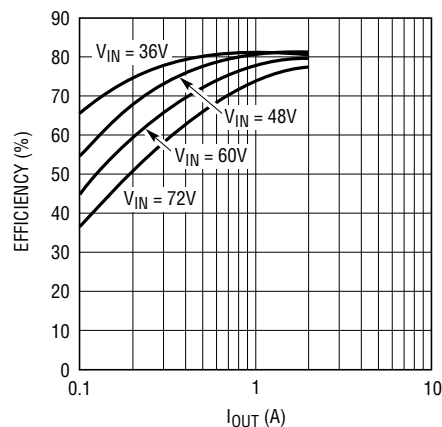

3803 TA02

3803i

ABSOLUTE MAXIMUM RATINGS

(Note 1)

V_{CC} to GND	
Low Impedance Source	-0.3V to 8V
Current Fed	25mA into V_{CC} *
NGATE Voltage	-0.3V to V_{CC}
V_{FB} , I_{TH}/RUN Voltages	-0.3V to 3.5V
SENSE Voltage	-0.3V to 1V
NGATE Peak Output Current (<10 μ s)	1A
Operating Temperature Range (Note 2) ..	-40°C to 85°C
Junction Temperature (Note 3)	150°C
Storage Temperature Range	-65°C to 150°C
Lead Temperature (Soldering, 10 sec)	300°C

*LTC3803 internal clamp circuit self regulates V_{CC} voltage to 9.5V.

PACKAGE/ORDER INFORMATION

	ORDER PART NUMBER
	LTC3803ES6
	S6 PART MARKING
	LTACV

Consult LTC Marketing for parts specified with wider operating temperature ranges.

ELECTRICAL CHARACTERISTICS

The ● indicates specifications which apply over the full operating temperature range, otherwise specifications are at $T_A = 25^\circ\text{C}$. $V_{CC} = 8\text{V}$, unless otherwise noted. (Note 2)

SYMBOL	PARAMETER	CONDITIONS	MIN	TYP	MAX	UNITS	
V_{TURNON}	V_{CC} Turn On Voltage		● 7.8	8.7	9.2	V	
$V_{TURNOFF}$	V_{CC} Turn Off Voltage		● 4.6	5.7	6.8	V	
V_{HYST}	V_{CC} Hysteresis	$V_{TURNON} - V_{TURNOFF}$	● 1.5	3.0		V	
$V_{CLAMP1mA}$	V_{CC} Shunt Regulator Voltage	$I_{CC} = 1\text{mA}$, $V_{ITH}/RUN = 0\text{V}$	● 8.3	9.4	10.3	V	
$V_{CLAMP25mA}$	V_{CC} Shunt Regulator Voltage	$I_{CC} = 25\text{mA}$, $V_{ITH}/RUN = 0\text{V}$	● 8.4	9.5	10.5	V	
V_{MARGIN}	$V_{CLAMP1mA} - V_{TURNON}$ Margin		● 0.05	0.6		V	
I_{CC}	Input DC Supply Current	(Note 4)					
	Normal Operation	$V_{ITH}/RUN = 1.3\text{V}$		240	350	μA	
	Start-Up	$V_{CC} = V_{TURNON} - 100\text{mV}$	●	40	90	μA	
$V_{ITHSHDN}$	Shutdown Threshold (at I_{TH}/RUN)	$V_{CC} = V_{TURNON} + 100\text{mV}$	● 0.15	0.28	0.45	V	
$I_{ITHSTART}$	Start-Up Current Source	$V_{ITH}/RUN = 0\text{V}$		0.2	0.3	μA	
V_{FB}	Regulated Feedback Voltage	$0^\circ\text{C} \leq T_A \leq 85^\circ\text{C}$ (Note 5)		0.788	0.800	0.812	V
		$-40^\circ\text{C} \leq T_A \leq 85^\circ\text{C}$ (Note 5)	●	0.780	0.800	0.812	V
g_m	Error Amplifier Transconductance	I_{TH}/RUN Pin Load = $\pm 5\mu\text{A}$ (Note 5)		200	333	500	$\mu\text{A}/\text{V}$
$\Delta V_{O(LINE)}$	Output Voltage Line Regulation	$V_{TURNOFF} < V_{CC} < V_{CLAMP}$ (Note 5)		0.05		mV/V	
$\Delta V_{O(LOAD)}$	Output Voltage Load Regulation	I_{TH}/RUN Sinking $5\mu\text{A}$ (Note 5)		3		mV/ μA	
		I_{TH}/RUN Sourcing $5\mu\text{A}$ (Note 5)		3		mV/ μA	
I_{FB}	V_{FB} Input Current	(Note 5)		10	50	nA	
f_{OSC}	Oscillator Frequency	$V_{ITH}/RUN = 1.3\text{V}$		180	200	240	kHz
$DC_{ON(MIN)}$	Minimum Switch On Duty Cycle	$V_{ITH}/RUN = 1.3\text{V}$, $V_{FB} = 0.8\text{V}$		6	8	%	
$DC_{ON(MAX)}$	Maximum Switch On Duty Cycle	$V_{ITH}/RUN = 1.3\text{V}$, $V_{FB} = 0.8\text{V}$		70	80	90	%
t_{RISE}	Gate Drive Rise Time	$C_{LOAD} = 3000\text{pF}$		40		ns	
t_{FALL}	Gate Drive Fall Time	$C_{LOAD} = 3000\text{pF}$		40		ns	
V_{IMAX}	Peak Current Sense Voltage	$R_{SL} = 0$ (Note 6)	● 90	100	115	mV	
I_{SLMAX}	Peak Slope Compensation Output Current	(Note 7)		5		μA	
t_{SFST}	Soft-Start Time			1.4		ms	

Note 1: Absolute Maximum Ratings are those values beyond which the life of a device may be impaired.

Note 2: The LTC3803E is guaranteed to meet specifications from 0°C to 70°C . Specifications over the -40°C to 85°C operating temperature range

are assured by design, characterization and correlation with statistical process controls.

Note 3: T_J is calculated from the ambient temperature T_A and power dissipation P_D according to the following formula:

ELECTRICAL CHARACTERISTICS

$$T_J = T_A + (P_D \cdot 230^\circ\text{C/W})$$

Note 4: Dynamic supply current is higher due to the gate charge being delivered at the switching frequency.

Note 5: The LTC3803 is tested in a feedback loop that servos V_{FB} to the output of the error amplifier while maintaining I_{TH}/RUN at the midpoint of the current limit range.

Note 6: Peak current sense voltage is reduced dependent on duty cycle and an optional external resistor in series with the SENSE pin (R_{SL}). For details, refer to the programmable slope compensation feature in the Applications Information section.

Note 7: Guaranteed by design.

TYPICAL PERFORMANCE CHARACTERISTICS

Reference Voltage vs Temperature

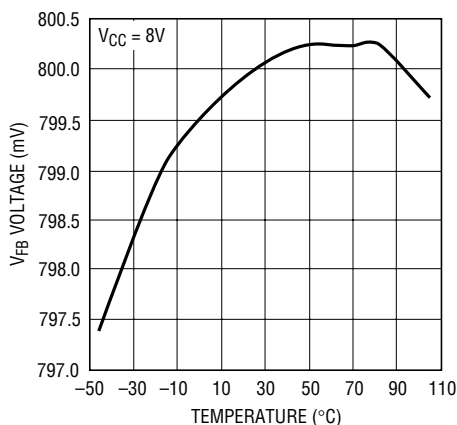

3803 G01

Reference Voltage vs Supply Voltage

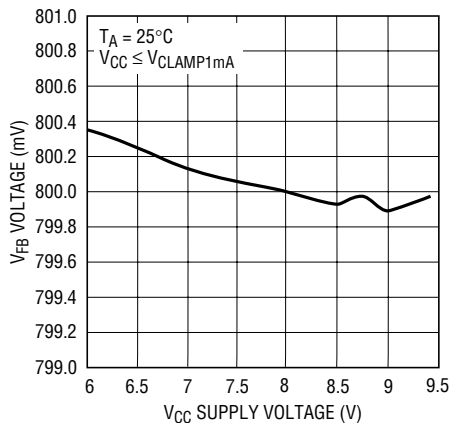

3803 F02

Reference Voltage vs V_{CC} Shunt Regulator Current

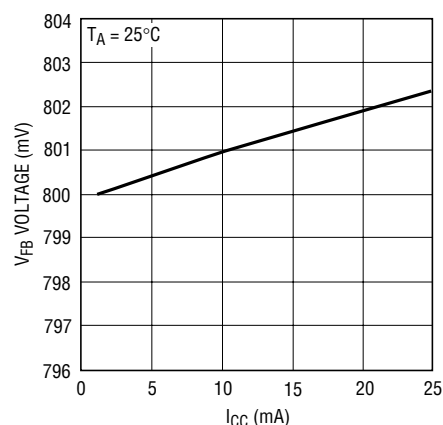

3803 G03

Oscillator Frequency vs Temperature

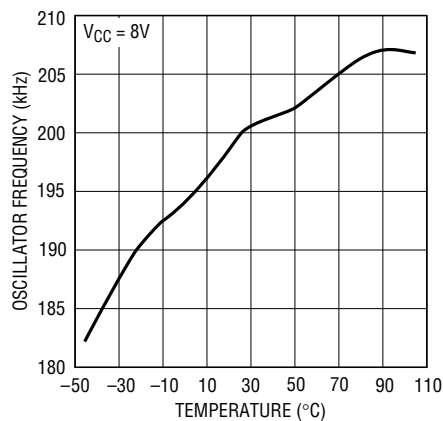

3803 G04

Oscillator Frequency vs Supply Voltage

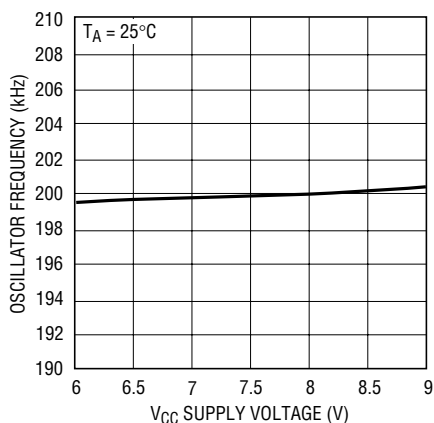

3803 G05

Oscillator Frequency vs V_{CC} Shunt Regulator Current

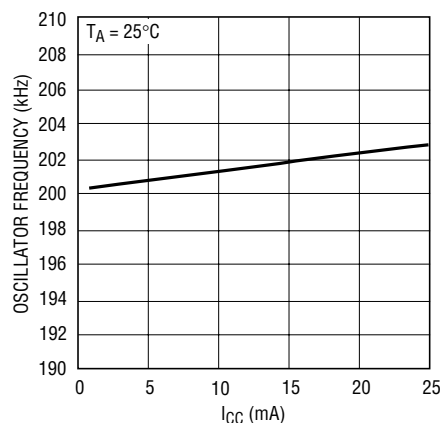

3803 G06

TYPICAL PERFORMANCE CHARACTERISTICS

V_{CC} Undervoltage Lockout Thresholds vs Temperature

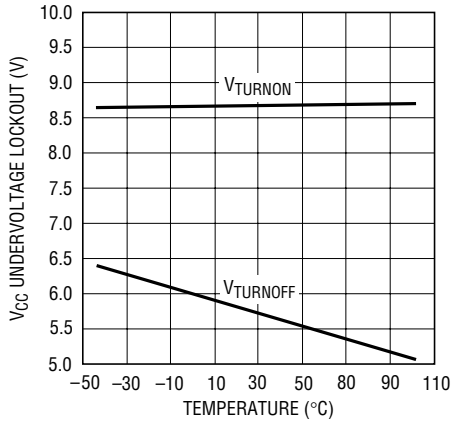

3803 G07

V_{CC} Shunt Regulator Voltage vs Temperature

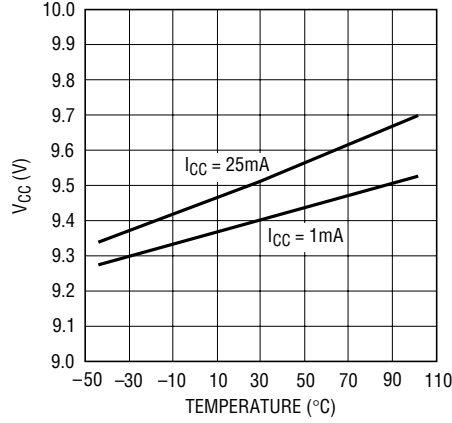

3803 G08

I_{CC} Supply Current vs Temperature

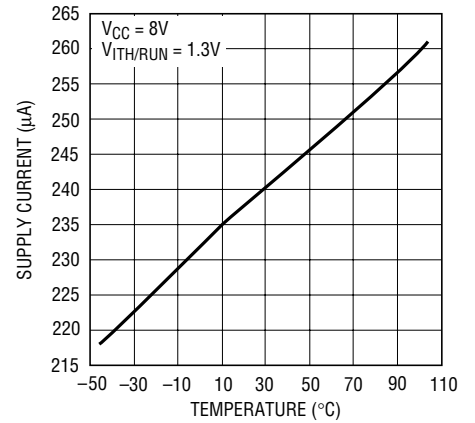

3803 G08

Start-Up I_{CC} Supply Current vs Temperature

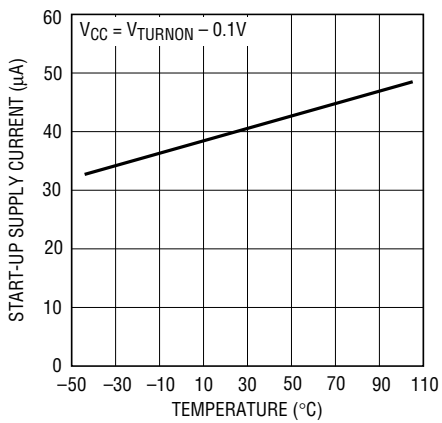

3803 G10

I_{TH}/RUN Shutdown Threshold vs Temperature

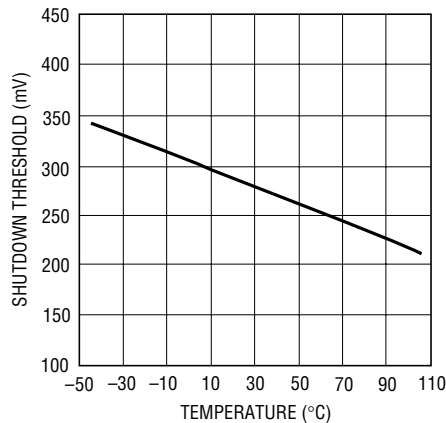

3803 G11

I_{TH}/RUN Start-Up Current Source vs Temperature

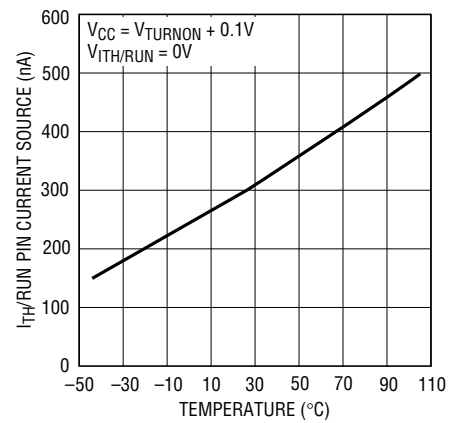

3803 G12

Peak Current Sense Voltage vs Temperature

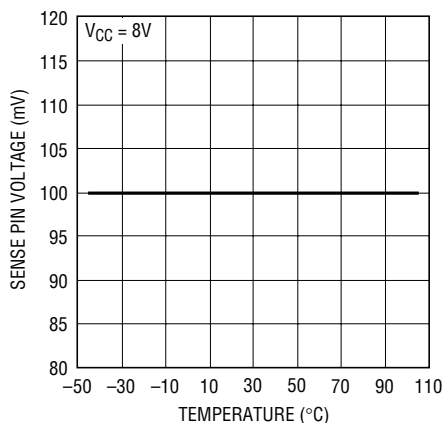

3803 G13

Soft-Start Time vs Temperature

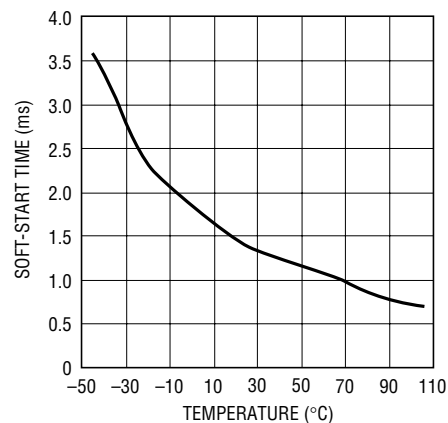

3803 G14

PIN FUNCTIONS

I_{TH}/RUN (Pin 1): This pin performs two functions. It serves as the error amplifier compensation point as well as the run/shutdown control input. Nominal voltage range is 0.7V to 1.9V. Forcing this pin below 0.28V causes the LTC3803 to shut down. In shutdown mode, the NGATE pin is held low.

GND (Pin 2): Ground Pin.

V_{FB} (Pin 3): Receives the feedback voltage from an external resistive divider across the output.

SENSE (Pin 4): This pin performs two functions. It monitors switch current by reading the voltage across an external current sense resistor to ground. It also injects a current ramp that develops slope compensation voltage across an optional external programming resistor.

V_{CC} (Pin 5): Supply Pin. Must be closely decoupled to GND (Pin 2).

NGATE (Pin 6): Gate Drive for the External N-Channel MOSFET. This pin swings from 0V to V_{CC}.

BLOCK DIAGRAM

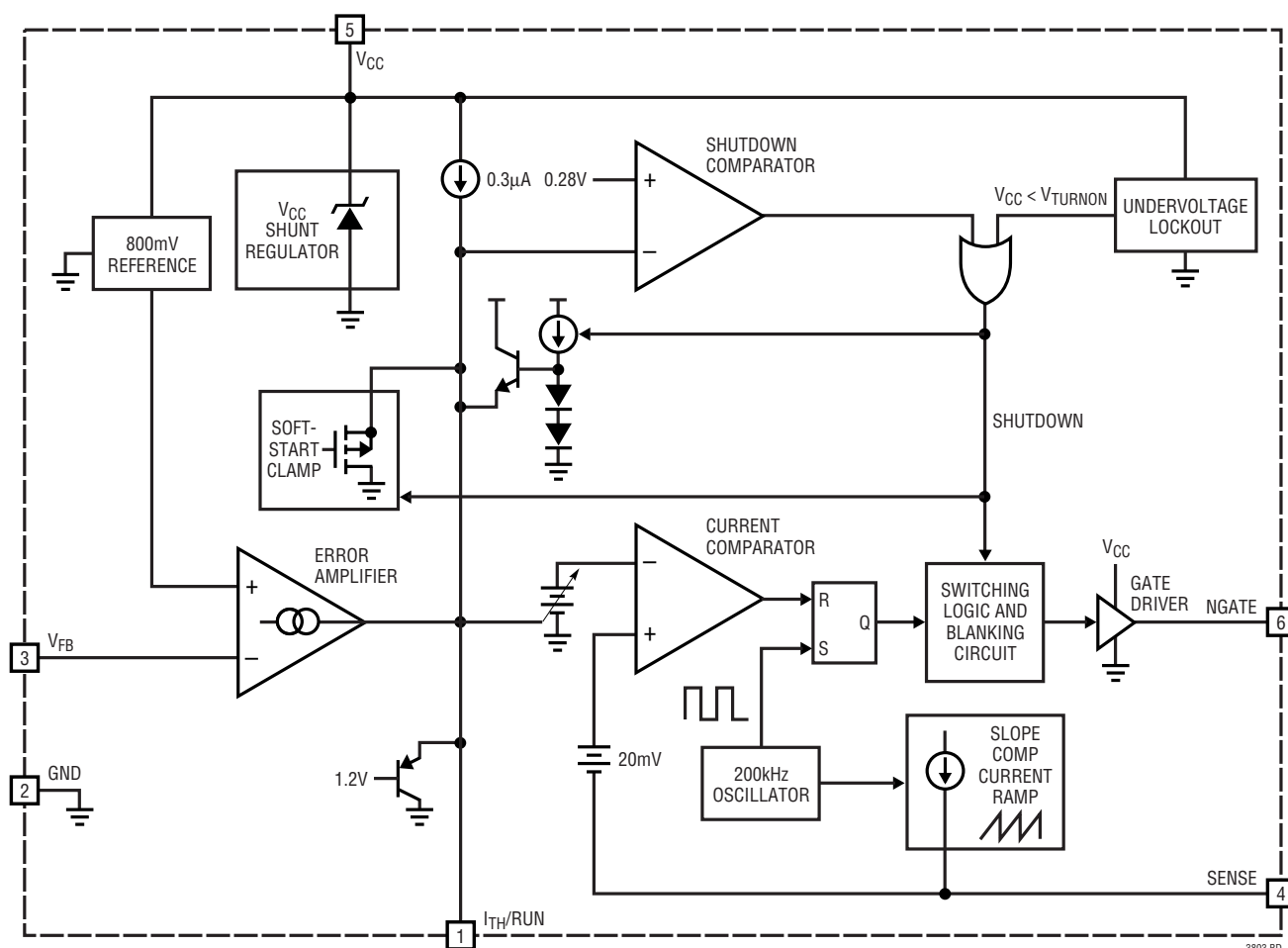

OPERATION

The LTC3803 is a constant frequency current mode controller for flyback and DC/DC boost converter applications in a tiny ThinSOT package. The LTC3803 is designed so that none of its pins need to come in contact with the input or output voltages of the power supply circuit of which it is a part, allowing the conversion of voltages well beyond the LTC3803's absolute maximum ratings.

Main Control Loop

Due to space limitations, the basics of current mode DC/DC conversion will not be discussed here; instead, the reader is referred to the detailed treatment in Application Note 19, or in texts such as Abraham Pressman's *Switching Power Supply Design*.

Please refer to the Block Diagram and the Typical Application on the front page of this data sheet. An external resistive voltage divider presents a fraction of the output voltage to the V_{FB} pin. The divider must be designed so that when the output is at the desired voltage, the V_{FB} pin voltage will equal the 800mV from the internal reference. If the load current increases, the output voltage will decrease slightly, causing the V_{FB} pin voltage to fall below 800mV. The error amplifier responds by feeding current into the I_{TH}/RUN pin. If the load current decreases, the V_{FB} voltage will rise above 800mV and the error amplifier will sink current away from the I_{TH}/RUN pin.

The voltage at the I_{TH}/RUN pin commands the pulse-width modulator formed by the oscillator, current comparator and RS latch. Specifically, the voltage at the I_{TH}/RUN pin sets the current comparator's trip threshold. The current comparator monitors the voltage across a current sense resistor in series with the source terminal of the external MOSFET. The LTC3803 turns on the external power MOSFET when the internal free-running 200kHz oscillator sets the RS latch. It turns off the MOSFET when the current comparator resets the latch or when 80% duty cycle is reached, whichever happens first. In this way, the peak current levels through the flyback transformer's primary and secondary is controlled by the I_{TH}/RUN voltage.

Since the I_{TH}/RUN voltage is increased by the error amplifier whenever the output voltage is below nominal, and

decreased whenever output voltage exceeds nominal, the voltage regulation loop is closed. For example, whenever the load current increases, output voltage will decrease slightly, and sensing this, the error amplifier raises the I_{TH}/RUN voltage by sourcing current into the I_{TH}/RUN pin, raising the current comparator threshold, thus increasing the peak currents through the transformer primary and secondary. This delivers more current to the load, bringing the output voltage back up.

The I_{TH}/RUN pin serves as the compensation point for the control loop. Typically, an external series RC network is connected from I_{TH}/RUN to ground and is chosen for optimal response to load and line transients. The impedance of this RC network converts the output *current* of the error amplifier to the I_{TH}/RUN *voltage* which sets the current comparator threshold and commands considerable influence over the dynamics of the voltage regulation loop.

Start-Up/Shutdown

The LTC3803 has two shutdown mechanisms to disable and enable operation: an undervoltage lockout on the V_{CC} supply pin voltage, and a forced shutdown whenever external circuitry drives the I_{TH}/RUN pin low. The LTC3803 transitions into and out of shutdown according to the state diagram (Figure 1).

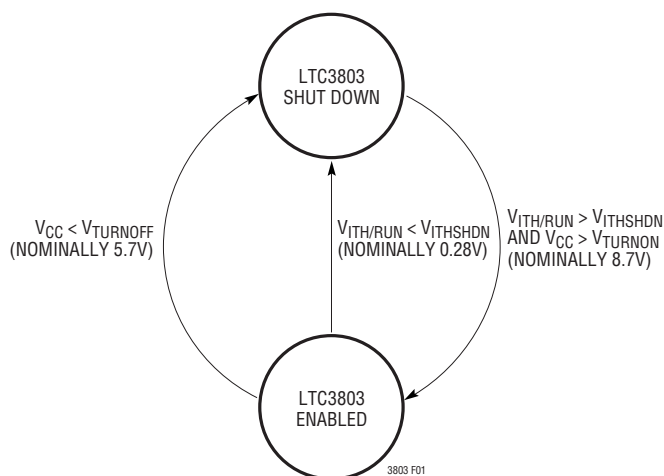

Figure 1. Start-Up/Shutdown State Diagram

OPERATION

The undervoltage lockout (UVLO) mechanism prevents the LTC3803 from trying to drive a MOSFET with insufficient V_{GS} . The voltage at the V_{CC} pin must exceed V_{TURNON} (nominally 8.7V) at least momentarily to enable LTC3803 operation. The V_{CC} voltage is then allowed to fall to $V_{TURNOFF}$ (nominally 5.7V) before undervoltage lockout disables the LTC3803. This wide UVLO hysteresis range supports the use of a bias winding on the flyback transformer to power the LTC3803—see the section Powering the LTC3803.

The I_{TH}/RUN pin can be driven below V_{SHDN} (nominally 0.28V) to force the LTC3803 into shutdown. An internal 0.3 μ A current source always tries to pull this pin towards V_{CC} . When the I_{TH}/RUN pin voltage is allowed to exceed V_{SHDN} , and V_{CC} exceeds V_{TURNON} , the LTC3803 begins to operate and an internal clamp immediately pulls the I_{TH}/RUN pin up to about 0.7V. In operation, the I_{TH}/RUN pin voltage will vary from roughly 0.7V to 1.9V to represent current comparator thresholds from zero to maximum.

Internal Soft-Start

An internal soft-start feature is enabled whenever the LTC3803 comes out of shutdown. Specifically, the I_{TH}/RUN voltage is clamped and is prevented from reaching maximum until roughly 1.4ms has passed. This allows the input and output currents of LTC3803-based power supplies to rise in a smooth and controlled manner on start-up.

Powering the LTC3803

In the simplest case, the LTC3803 can be powered from a high voltage supply through a resistor. A built-in shunt regulator from the V_{CC} pin to GND will draw as much current as needed through this resistor to regulate the V_{CC} voltage to around 9.4V as long as the V_{CC} pin is not forced to sink more than 25mA. This shunt regulator is always active, even when the LTC3803 is in shutdown, since it serves the vital function of protecting the V_{CC} pin from seeing too much voltage.

For higher efficiency or for wide V_{IN} range applications, flyback controllers are typically powered through a separate bias winding on the flyback transformer. The LTC3803 has a wide UVLO hysteresis (1.5V min) and small V_{CC} supply current draw (<90 μ A when $V_{CC} < V_{TURNON}$) that is needed to support such bootstrapped hysteretic start-up schemes.

The V_{CC} pin must be bypassed to ground immediately adjacent to the IC pins with a minimum of a 10 μ F ceramic or tantalum capacitor. Proper supply bypassing is necessary to supply the high transient currents required by the MOSFET gate driver.

Adjustable Slope Compensation

The LTC3803 injects a 5 μ A peak current ramp out through its SENSE pin which can be used for slope compensation in designs that require it. This current ramp is approximately linear and begins at zero current at 6% duty cycle, reaching peak current at 80% duty cycle. Additional details are provided in the Applications Information section.

APPLICATIONS INFORMATION

Many LTC3803 application circuits can be derived from the topology shown in Figure 2.

The LTC3803 itself imposes no limits on allowed power output, input voltage V_{IN} or desired regulated output voltage V_{OUT} ; these are all determined by the ratings on the external power components. The key factors are: Q1's maximum drain-source voltage (BV_{DSS}), on-resistance ($R_{DS(ON)}$) and maximum drain current, T1's saturation flux level and winding insulation breakdown voltages, C_{IN} and C_{OUT} 's maximum working voltage, ESR, and maximum ripple current ratings, and D1 and R_{SENSE} 's power ratings.

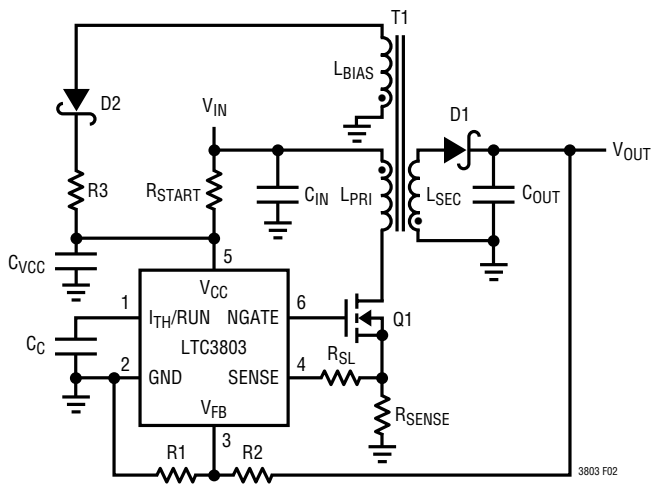

Figure 2. Typical LTC3803 Application Circuit

SELECTING FEEDBACK RESISTOR DIVIDER VALUES

The regulated output voltage is determined by the resistor divider across V_{OUT} ($R1$ and $R2$ in Figure 2). The ratio of $R2$ to $R1$ needed to produce a desired V_{OUT} can be calculated:

$$R2 = \frac{V_{OUT} - 0.8V}{0.8V} \cdot R1$$

Choose resistance values for $R1$ and $R2$ to be as large as possible in order to minimize any efficiency loss due to the static current drawn from V_{OUT} , but just small enough so that when V_{OUT} is in regulation, the error caused by the nonzero input current to the V_{FB} pin is less than 1%. A good rule of thumb is to choose $R1$ to be 80k or less.

TRANSFORMER DESIGN CONSIDERATIONS

Transformer specification and design is perhaps the most critical part of applying the LTC3803 successfully. In addition to the usual list of caveats dealing with high frequency power transformer design, the following should prove useful.

Turns Ratios

Due to the use of the external feedback resistor divider ratio to set output voltage, the user has relative freedom in selecting transformer turns ratio to suit a given application. Simple ratios of small integers, e.g., 1:1, 2:1, 3:2, etc. can be employed which yield more freedom in setting total turns and mutual inductance. Simple integer turns ratios also facilitate the use of “off-the-shelf” configurable transformers such as the Coiltronics VERSA-PAC™ series in applications with high input to output voltage ratios. For example, if a 6-winding VERSA-PAC is used with three windings in series on the primary and three windings in parallel on the secondary, a 3:1 turns ratio will be achieved.

Turns ratio can be chosen on the basis of desired duty cycle. However, remember that the input supply voltage plus the secondary-to-primary referred version of the flyback pulse (including leakage spike) must not exceed the allowed external MOSFET breakdown rating.

Leakage Inductance

Transformer leakage inductance (on either the primary or secondary) causes a voltage spike to occur after the output switch (Q1) turn-off. This is increasingly prominent at higher load currents, where more stored energy must be dissipated. In some cases a “snubber” circuit will be required to avoid overvoltage breakdown at the MOSFET's drain node. Application Note 19 is a good reference on snubber design.

A bifilar or similar winding technique is a good way to minimize troublesome leakage inductances. However, remember that this will limit the primary-to-secondary breakdown voltage, so bifilar winding is not always practical.

VERSA-PAC is a trademark of Coiltronics, Inc.

APPLICATIONS INFORMATION

CURRENT SENSE RESISTOR CONSIDERATIONS

The external current sense resistor (R_{SENSE} in Figure 2) allows the user to optimize the current limit behavior for the particular application. As the current sense resistor is varied from several ohms down to tens of milliohms, peak switch current goes from a fraction of an ampere to several amperes. Care must be taken to ensure proper circuit operation, especially with small current sense resistor values.

For example, a peak switch current of 5A requires a sense resistor of 0.020Ω . Note that the instantaneous peak power in the sense resistor is $0.5W$ and it must be rated accordingly. The LTC3803 has only a single sense line to this resistor. Therefore, any parasitic resistance in the ground side connection of the sense resistor will increase its apparent value. In the case of a 0.020Ω sense resistor, *one milliohm* of parasitic resistance will cause a 5% reduction in peak switch current. So the resistance of printed circuit copper traces and vias cannot necessarily be ignored.

PROGRAMMABLE SLOPE COMPENSATION

The LTC3803 injects a ramping current through its SENSE pin into an external slope compensation resistor (R_{SL} in Figure 2). This current ramp starts at zero right after the NGATE pin has been high for the LTC3803's minimum duty cycle of 6%. The current rises linearly towards a peak of $5\mu A$ at the maximum duty cycle of 80%, shutting off once the NGATE pin goes low. A series resistor (R_{SL}) connecting the SENSE pin to the current sense resistor (R_{SENSE}) thus develops a ramping voltage drop. From the perspective of the SENSE pin, this ramping voltage adds to the voltage across the sense resistor, effectively reducing the current comparator threshold in proportion to duty cycle. This stabilizes the control loop against subharmonic oscillation. The amount of reduction in the current comparator threshold (ΔV_{SENSE}) can be calculated using the following equation:

$$\Delta V_{SENSE} = \frac{\text{Duty Cycle} - 6\%}{74\%} \cdot 5\mu A \cdot R_{SL}$$

Note: LTC3803 enforces $6\% < \text{Duty Cycle} < 80\%$.

A good starting value for R_{SL} is $5.9k$, which gives a $30mV$ drop in current comparator threshold at 80% duty cycle. Designs not needing slope compensation may replace R_{SL} with a short circuit.

INTERNAL WIDE HYSTERESIS UNDERVOLTAGE LOCKOUT

The LTC3803 is designed to implement DC/DC converters operating from input voltages of typically 48V or more. The standard operating topology employs a third transformer winding (L_{BIAS} in Figure 2) on the primary side that provides power for the LTC3803 via its V_{CC} pin. However, this arrangement is not inherently self-starting. Start-up is affected by the use of an external "trickle-charge" resistor (R_{START} in Figure 2) and the presence of an internal wide hysteresis undervoltage lockout circuit that monitors V_{CC} pin voltage. Operation is as follows:

"Trickle charge" resistor R_{START} is connected to V_{IN} and supplies a small current, typically on the order of $100\mu A$, to charge C_{VCC} . After some time, the voltage on C_{VCC} reaches the V_{CC} turn-on threshold. The LTC3803 then turns on abruptly and draws its normal supply current. The NGATE pin begins switching and the external MOSFET (Q1) begins to deliver power. The voltage on C_{VCC} begins to decline as the LTC3803 draws its normal supply current, which exceeds that delivered by R_{START} . After some time, typically tens of milliseconds, the output voltage approaches its desired value. By this time, the third transformer winding is providing virtually all the supply current required by the LTC3803.

One potential design pitfall is undersizing the value of capacitor C_{VCC} . In this case, the normal supply current drawn by the LTC3803 will discharge C_{VCC} too rapidly; before the third winding drive becomes effective, the V_{CC} turn-off threshold will be reached. The LTC3803 turns off, and the V_{CC} node begins to charge via R_{START} back up to the V_{CC} turn-on threshold. Depending on the particular situation, this may result in either several on-off cycles before proper operation is reached or permanent relaxation oscillation at the V_{CC} node.

APPLICATIONS INFORMATION

Component selection is as follows:

Resistor R_{START} should be made small enough to yield a worst-case minimum charging current greater than the maximum rated LTC3803 start-up current, to ensure there is enough current to charge C_{VCC} to the V_{CC} turn-on threshold. It should be made large enough to yield a worst-case maximum charging current less than the minimum rated LTC3803 supply current, so that in operation, most of the LTC3803's supply current is delivered through the third winding. This results in the highest possible efficiency.

Capacitor C_{VCC} should then be made large enough to avoid the relaxation oscillation behavior described above. This is complicated to determine theoretically as it depends on the particulars of the secondary circuit and load behavior. Empirical testing is recommended.

The third transformer winding should be designed so that its output voltage, after accounting for the D2's forward voltage drop, exceeds the maximum V_{CC} turn-off threshold. Also, the third winding's nominal output voltage should be at least 0.5V below the minimum rated V_{CC} clamp voltage to avoid running up against the LTC3803's V_{CC} shunt regulator, needlessly wasting power.

V_{CC} SHUNT REGULATOR

In applications including a third transformer winding, the internal V_{CC} shunt regulator serves to protect the LTC3803

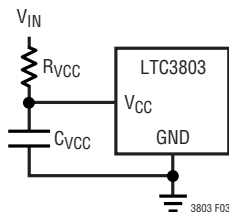

Figure 3. Powering the LTC3803 Via the Internal Shunt Regulator

from overvoltage transients as the third winding is powering up.

In applications where a third transformer winding is undesirable or unavailable, the shunt regulator allows the LTC3803 to be powered through a single dropping resistor from V_{IN} to V_{CC} , in conjunction with a bypass capacitor, C_{VCC} , that closely decouples V_{CC} to GND (see Figure 3). This simplicity comes at the expense of reduced efficiency due to the static power dissipation in the R_{VCC} dropping resistor.

The shunt regulator can draw up to 25mA through the V_{CC} pin to GND to drop enough voltage across R_{VCC} to regulate V_{CC} to around 9.5V. For applications where V_{IN} is low enough such that the static power dissipation in R_{VCC} is acceptable, using the V_{CC} shunt regulator is the simplest way to power the LTC3803.

EXTERNAL PREREGULATOR

The circuit in Figure 4 shows a third way to power the LTC3803. An external series preregulator consisting of series pass transistor Q1, Zener diode D1, and bias resistor R_B brings V_{CC} to at least 7.6V nominal, well above the maximum rated V_{CC} turn-off threshold of 6.8V. Resistor R_{START} momentarily charges the V_{CC} node up to the V_{CC} turn-on threshold, enabling the LTC3803.

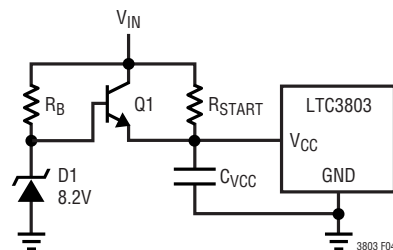
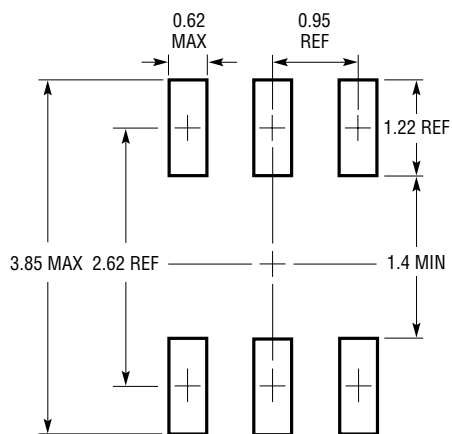

Figure 4. Powering the LTC3803 with an External Preregulator

PACKAGE DESCRIPTION

S6 Package
6-Lead Plastic TSOT-23
 (Reference LTC DWG # 05-08-1636)



RECOMMENDED SOLDER PAD LAYOUT
 PER IPC CALCULATOR

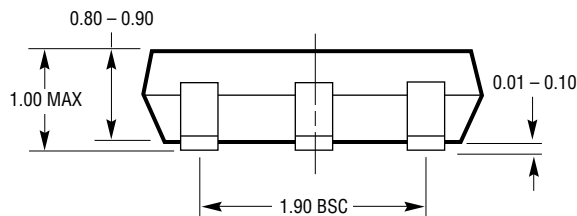
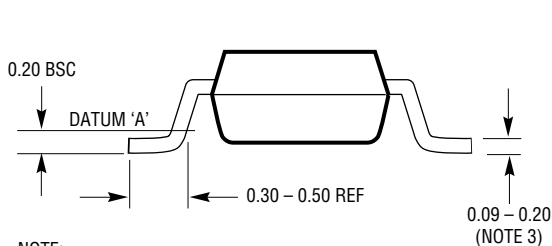
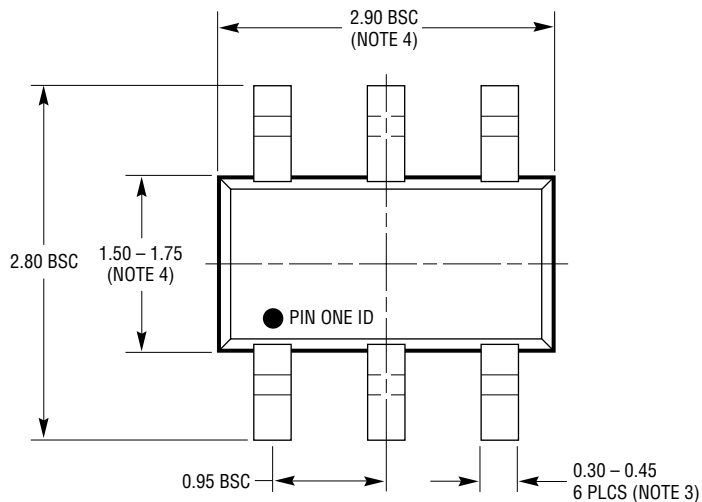

S6 TSOT-23 0302

- NOTE:
1. DIMENSIONS ARE IN MILLIMETERS
 2. DRAWING NOT TO SCALE
 3. DIMENSIONS ARE INCLUSIVE OF PLATING
 4. DIMENSIONS ARE EXCLUSIVE OF MOLD FLASH AND METAL BURR
 5. MOLD FLASH SHALL NOT EXCEED 0.254mm
 6. JEDEC PACKAGE REFERENCE IS MO-193

TYPICAL APPLICATION

2W Housekeeping Telecom Converter

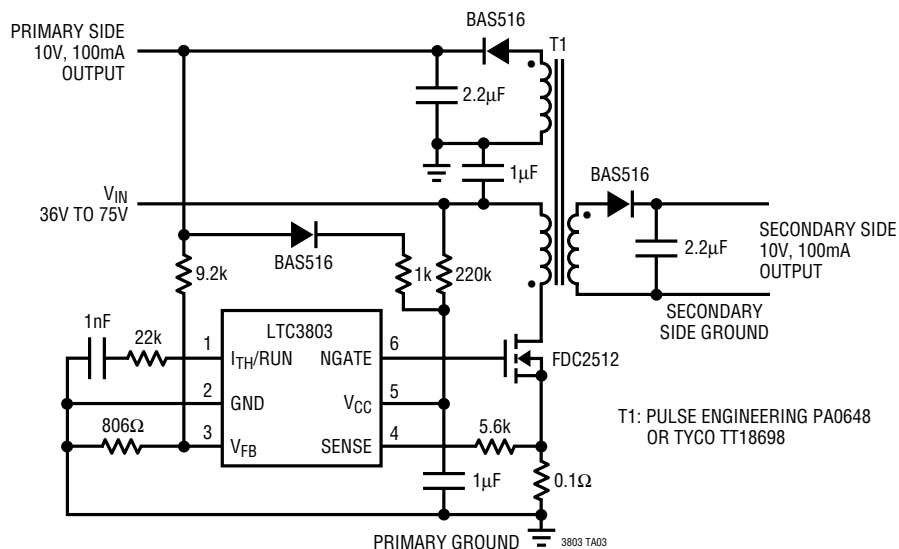

RELATED PARTS

PART NUMBER	DESCRIPTION	COMMENTS
LT [®] 1425	Isolated Flyback Switching Regulator with No External Power Devices	No Optoisolator or "Third Winding" Required, Up to 6W Output
LT1725	General Purpose Isolated Flyback Controller	No Optoisolator Required, V_{IN} and V_{OUT} Limited Only by External Power Components
LTC1772	SOT-23 Constant Frequency Current Mode Step-Down DC/DC Controller	550kHz Switching Frequency, 2.4V to 9.8V V_{IN} Range
LTC1871	Wide Input Range, No R_{SENSE} ™ Current Mode Flyback, Boost and SEPIC Controller	Adjustable Switching Frequency, Programmable Undervoltage Lockout, Optional Burst Mode [®] Operation at Light Load
LTC1872	SOT-23 Constant Frequency Current Mode Boost DC/DC Controller	550kHz Switching Frequency, 2.4V to 9.8V V_{IN} Range
LT1950	Current Mode PWM Controller	Controller for Forward Converters from 30W to 300W
LT3420	Photoflash Capacitor Charger with Automatic Refresh	Specialized Flyback Charges High Voltage Photoflash Capacitors Quickly and Efficiently

Burst Mode is a registered trademark of Linear Technology Corporation. No R_{SENSE} is a trademark of Linear Technology Corporation.