

10V, High Efficiency, Synchronous, No R_{SENSE} [™] Buck-Boost Controller

FEATURES

- Single Inductor Architecture Allows V_{IN} Above, Below or Equal to V_{OUT}
- 2.7V to 10V Input and Output Range
- Up to 96% Efficiency
- Up to 10A of Output Current
- All N-Channel MOSFETs, No R_{SENSE}
- True Output Disconnect During Shutdown
- Programmable Current Limit and Soft-Start
- Optional Short-Circuit Shutdown Timer
- Output Overvoltage and Undervoltage Protection
- Programmable Frequency: 100kHz to 1MHz
- Selectable Burst Mode[®] Operation
- Available in 24-Lead (4mm × 4mm) Exposed Pad QFN Package

APPLICATIONS

- Palmtop Computers
- Handheld Instruments
- Wireless Modems
- Cellular Telephones

DESCRIPTION

The LTC[®]3785 is a high power synchronous buck-boost controller that drives all N-channel power MOSFETs from input voltages above, below and equal to the output voltage. With an input range of 2.7V to 10V, the LTC3785 is well suited for a wide variety of single or dual cell Li-Ion or multi-cell alkaline/NiMH applications.

The operating frequency can be programmed from 100kHz to 1MHz. The soft-start time and current limit are also programmable. The soft-start capacitor doubles as the fault timer which can program the IC to latch off or recycle after a determined off time. Burst Mode operation is user controlled and can be enabled by driving the MODE pin high.

Protection features include foldback current limit, short-circuit and overvoltage protection.

LT, LT, LTC, LTM and Burst Mode are registered trademarks of Linear Technology Corporation. No R_{SENSE} is a trademark of Linear Technology Corporation. All other trademarks are the property of their respective owners.

TYPICAL APPLICATION

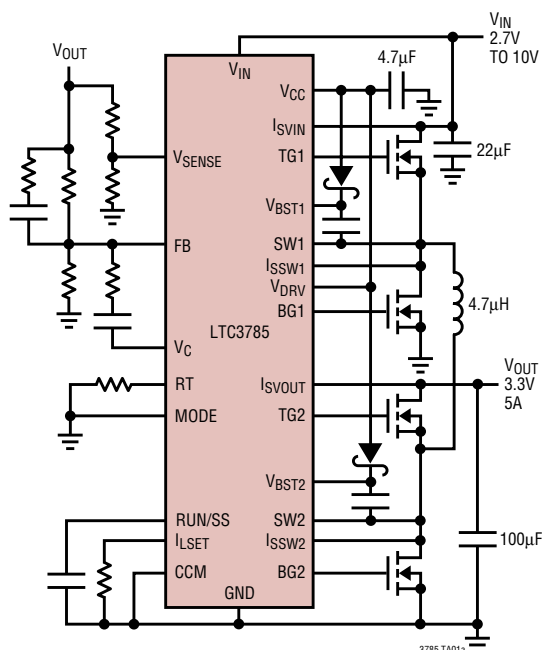

Efficiency vs Input Voltage

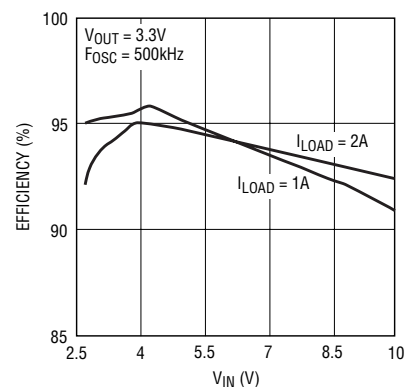

3785 TA01b

LTC3785

ABSOLUTE MAXIMUM RATINGS

(Note 1)

Input Supply Voltage (V_{IN})	-0.3V to 11V
I_{SVOUT} , I_{SVIN}	-0.3V to 11V
SW1, SW2, I_{SSW1} , I_{SSW2} Voltage:	
DC	-1V to 11V
Pulsed, $<1\mu s$	-2V to 12V
RUN/SS, MODE, CCM, V_{DRV} , V_{CC} Voltages	-0.3V to 6V
TG1, V_{BST1} Voltages	-0.3V to 16V
With Respect to SW1	-0.3V to 6V
TG2, V_{BST2} Voltages	-0.3V to 16V
With Respect to SW2	-0.3V to 6V
BG1, BG2 Voltage	-0.3V to 6V
Peak Driver Output Current $< 10\mu s$ (TG1, TG2, BG1, BG2)	3A
V_{CC} Average Output Current	100mA
Operating Temperature Range	-40°C to 85°C
Storage Temperature Range	-65°C to 125°C

PIN CONFIGURATION

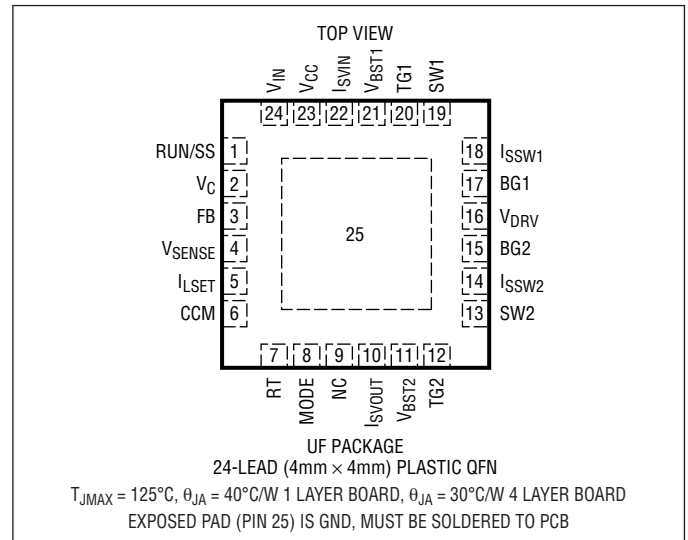

ORDER INFORMATION

LEAD FREE FINISH	TAPE AND REEL	PART MARKING	PACKAGE DESCRIPTION	TEMPERATURE RANGE
LTC3785EUF#PBF	LTC3785EUF#TRPBF	3785	24-Lead (4mm × 4mm) Plastic QFN	-40°C to 85°C
LEAD BASED FINISH	TAPE AND REEL	PART MARKING	PACKAGE DESCRIPTION	TEMPERATURE RANGE
LTC3785EUF	LTC3785EUF#TR	3785	24-Lead (4mm × 4mm) Plastic QFN	-40°C to 85°C

Consult LTC Marketing for parts specified with wider operating temperature ranges.

For more information on lead free part marking, go to: <http://www.linear.com/leadfree/>

For more information on tape and reel specifications, go to: <http://www.linear.com/tapeandreel/>

ELECTRICAL CHARACTERISTICS

The ● denotes the specifications which apply over the full operating temperature range, otherwise specifications are at $T_A = 25^{\circ}C$. $V_{IN} = V_{OUT} = V_{DRV} = V_{BST1} = V_{BST2} = 3.6V$, $R_T = 49.9k$, $R_{ILSET} = 59k$.

PARAMETER	CONDITIONS	MIN	TYP	MAX	UNITS
V_{IN} Supply					
Input Operating Voltage		● 2.7		10	V
Quiescent Current—Burst Mode Operation	$V_C = 0V$, MODE = 3.6V (Note 4)		86	200	μA
Quiescent Current—Shutdown	RUN/SS = 0V, $V_{OUT} = 0V$		15	25	μA
Quiescent Current—Active	MODE = 0V (Note 4)		0.8	1.5	mA
Error Amp					
Feedback Voltage	(Note 5)	● 1.200	1.225	1.25	V
Feedback Input Current	(Note 5)		1	500	nA
Error Amp Source Current			-500		μA
Error Amp Sink Current			900		μA
Error Amp A_{VOL}			90		dB
Overshoot Threshold	V_{SENSE} Pin. % Above FB	● 6	10	14	%

3785f

ELECTRICAL CHARACTERISTICS

The ● denotes the specifications which apply over the full operating temperature range, otherwise specifications are at $T_A = 25^\circ\text{C}$. $V_{IN} = V_{OUT} = V_{DRV} = V_{BST1} = V_{BST2} = 3.6\text{V}$, $R_T = 49.9\text{k}$, $R_{ILSET} = 59\text{k}$.

PARAMETER	CONDITIONS		MIN	TYP	MAX	UNITS
Undervoltage Threshold	V_{SENSE} Pin. % Below FB	●	-3.5	-6.5	-9.5	%
V_{SENSE} Input Current	$V_{SENSE} = \text{Measured FB Voltage}$			1	500	nA
V_{CC} Regulator						
V_{CC} Maximum Regulating Voltage	$V_{IN} = 5\text{V}$, $I_{VCC} = -20\text{mA}$	●	4.15	4.35	4.55	V
V_{CC} Regulation Voltage	$V_{IN} = 3.6\text{V}$, $I_{VCC} = -20\text{mA}$	●	3.3	3.5	3.6	V
V_{CC} Regulator Sink Current	$V_{OUT} = V_{CC} = 5\text{V}$			800		μA
Run/Soft-Start						
RUN/SS Threshold	When IC is Enabled When EA is at Maximum Boost Duty Cycle	●	0.35	0.7 1.9	1.1	V V
RUN/SS Input Current	RUN/SS = 0V			-1		μA
RUN/SS Discharge Current	During Current Limit			1	5	μA
Current Limit						
Current Limit Sense Threshold	I_{SVIN} to I_{SSW1} , $R_{ILSET} = 121\text{k}$ I_{SVIN} to I_{SSW1} , $R_{ILSET} = 59\text{k}$	●	20	60	100	mV
		●	55	105	155	mV
Reverse Current Limit Sense Threshold	I_{SSW2} to I_{SVOUT} , CCM > 2V I_{SSW2} to I_{SVOUT} , CCM < 0.4V	●	-50	-110	-170	mV
		●		-15	-35	mV
Input Current	I_{SVIN} I_{SVOUT} I_{SSW1} , I_{SSW2}			80	150	μA
				10	20	μA
				0.1	5	μA
CCM Input Threshold (High)		●	2.2			V
CCM Input Threshold (Low)		●			0.4	V
CCM Input Current				0.01	1	μA
Burst Mode Operation						
Mode Threshold		●	0.8	1.5	2.2	V
Mode Input Current				0.01	1	μA
t_{ON} Time				1.4		μs
Oscillator						
Frequency Accuracy		●	370	509	650	kHz
Switching Characteristics						
Maximum Duty Cycle	Boost (% Switch BG2 On) Buck (% Switch TG1 On)	●	80	90		%
				99		%
TG1, TG2 Driver Impedance				2		Ω
BG1, BG2 Driver Impedance				2		Ω
TG1, TG2 Rise Time	$C_{LOAD} = 3300\text{pF}$ (Note 3)			20		ns
BG1, BG2 Rise Time	$C_{LOAD} = 3300\text{pF}$ (Note 3)			20		ns
TG1, TG2 Fall Time	$C_{LOAD} = 3300\text{pF}$ (Note 3)			20		ns
BG1, BG2 Fall Time	$C_{LOAD} = 3300\text{pF}$ (Note 3)			20		ns
Buck Driver Nonoverlap Time	TG1 to BG1			100		ns
Boost Driver Nonoverlap Time	TG2 to BG2			100		ns

Note 1: Stresses beyond those listed under Absolute Maximum Ratings may cause permanent damage to the device. Exposure to any Absolute Maximum Rating condition for extended periods may affect device reliability and lifetime.

Note 2: The LTC3785E is guaranteed to meet performance specifications from 0°C to 85°C . Specifications over -40°C to 85°C operating

temperature range are assured by design, characterization and correlation with statistical process controls.

Note 3: Specification is guaranteed by design and not 100% tested in production.

Note 4: Current measurements are performed when the outputs are not switching.

Note 5: The IC is tested in a feedback loop to make the measurement.

TYPICAL PERFORMANCE CHARACTERISTICS ($T_A = 25^\circ\text{C}$ unless otherwise noted)

Li-Ion to 3.3V Efficiency vs Load Current

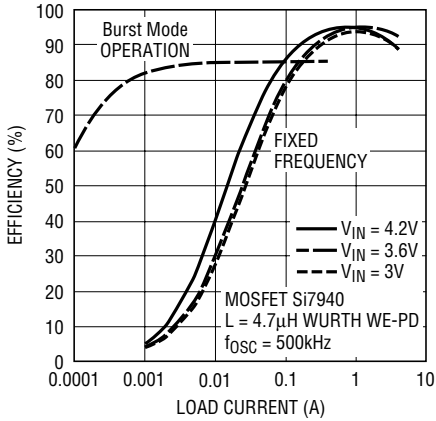

3785 G01

Two Li-Ion to 7V Efficiency vs Load Current

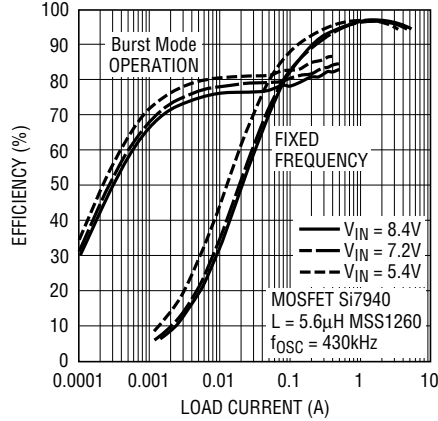

3785 G02

Li-Ion/9V to 5V VOUT Efficiency vs Load Current

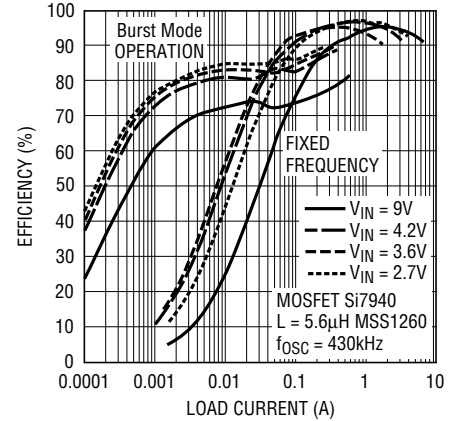

3785 G02

Burst Mode Ripple

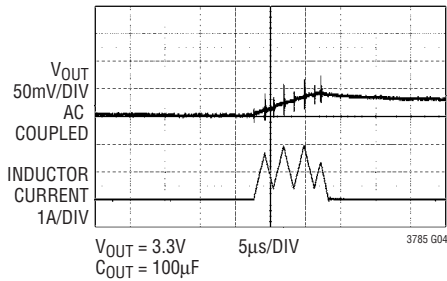

3785 G04

Line Transient Response

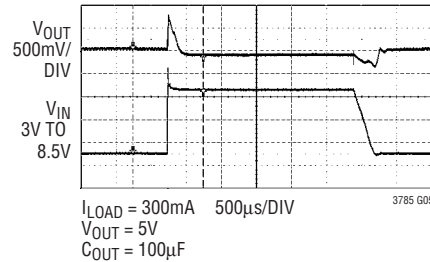

3785 G05

VOUT Load Transient

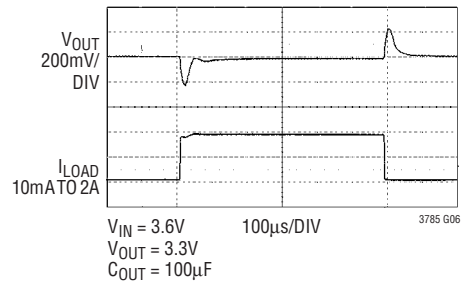

3785 G06

VFB vs Temperature

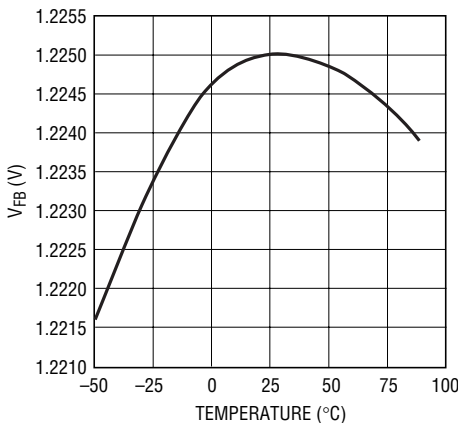

3785 G07

Normalized Oscillator Frequency vs Temperature

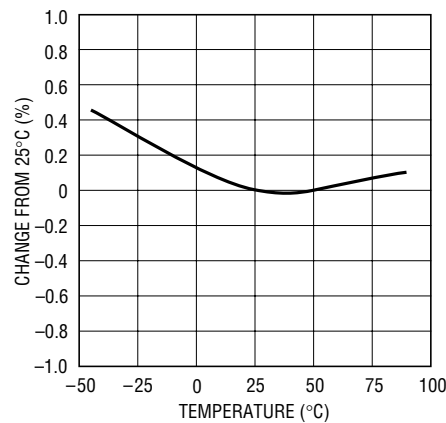

3785 G08

Oscillator Frequency vs RT

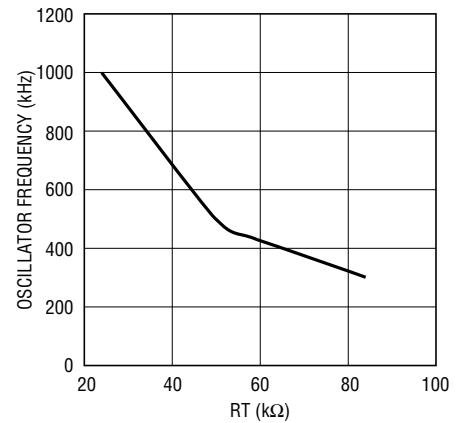

3785 G09

TYPICAL PERFORMANCE CHARACTERISTICS ($T_A = 25^\circ\text{C}$ unless otherwise noted)

V_{IN} Start-Up Voltage vs Temperature

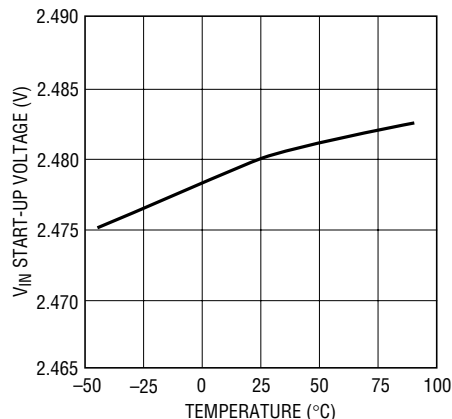

3785 G10

V_{IN} Burst Quiescent Current vs Temperature

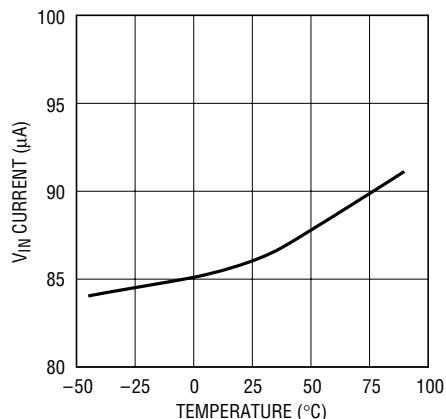

3785 G11

OV and UV Thresholds vs Temperature

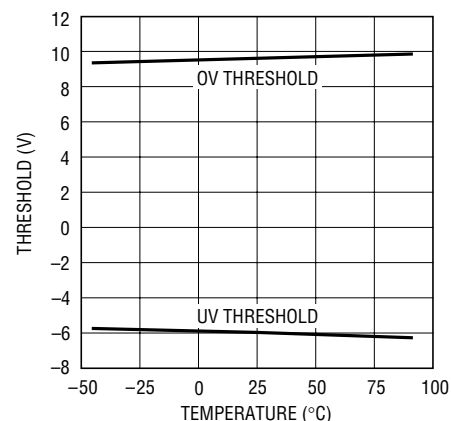

3785 G12

PIN FUNCTIONS

RUN/SS (Pin 1): Run Control and Soft-Start Input. An internal $1\mu\text{A}$ charges the soft-start capacitor and will charge to approximately 2.5V. During a current limit fault, the soft-start capacitor will incrementally discharge. Once the pin drops below 1.225V the IC will enter fault mode, turning off the outputs for 32 times the soft-start time. If $>5\mu\text{A}$ (at $\text{RUN/SS} = 1.225\text{V}$) is applied externally, the part will latch off after a fault is detected. If $>40\mu\text{A}$ (at $\text{RUN/SS} = 1.225\text{V}$) is applied externally, current limit faults will not discharge the SS capacitor.

V_C (Pin 2): Error Amp Output. A frequency compensation network is connected from this pin to the FB pin to compensate the loop. See the section “Closing the Feedback Loop” for guidelines.

FB (Pin 3): Feedback Pin. Connect resistor divider tap here. The feedback reference voltage is typically 1.225V. The output voltage can be adjusted from 2.7V to 10V according to the following formula:

$$V_{\text{OUT}} = 1.225\text{V} \cdot \frac{R1 + R2}{R2}$$

V_{SENSE} (Pin 4): Overvoltage and Undervoltage Sense. The overvoltage threshold is internally set 10% above the regulated FB voltage and the undervoltage threshold is internally set 6.5% below the FB regulated voltage. This pin can be tied to FB but to optimize the response time it is recommended that a voltage divider from V_{OUT} be applied. The divider can be skewed from the feedback value to achieve the desired UV or OV threshold.

I_{LSET} (Pin 5): Current Limit Set. A resistor from this pin to ground sets the current limit threshold from the I_{SVIN} and I_{SSW1} pins.

CCM (Pin 6): Continuous Conduction Mode Control Pin. When set low, the inductor current is allowed to go slightly negative (-15mV referenced to the $I_{\text{SVOUT}} - I_{\text{SSW2}}$ pins). When driven high, the reverse current limit is set to the similar value of the forward current limit set by the I_{LSET} pin.

RT (Pin 7): Oscillator Programming Pin. A resistor from this pin to GND sets the free-running frequency of the IC. $f_{\text{OSC}} \approx 2.5e10/\text{RT}$.

PIN FUNCTIONS

MODE (Pin 8): Burst Mode Control Pin.

- **MODE = High:** Enable Burst Mode Operation. In Burst Mode operation the operation is variable frequency, which provides a significant efficiency improvement at light loads. The Burst Mode operation will continue until the pin is driven low.
- **MODE = Low:** Disable Burst Mode operation and maintain low noise, constant frequency operation.

NC (Pin 9): No Connect. There is no electrical connection to this pin inside the package.

I_{SVOUT} (Pin 10): Reverse Current Limit Comparator Non-inverting Input. This pin is normally connected to the drain of the N-channel MOSFET D (TG2 driven).

V_{BST2} (Pin 11): Boosted Floating Driver Supply for Boost Switch D. This pin will swing from a diode below V_{CC} up to $V_{OUT} + V_{CC} - V_{DIODE}$.

SW2 (Pin 13): Ground Reference for Driver D. Gate drive from TG2 will reference to the common point of output switches C and D.

I_{SSW2} (Pin 14): Reverse Current Limit Comparator Inverting Input. This pin is normally connected to the source of the N-channel MOSFET D (TG2 driven).

V_{DRV} (Pin 16): Driver Supply for Ground Referenced Switches. Connect this pin to V_{CC} potential.

BG1, BG2 (Pins 17, 15): Bottom gate driver pins drive the ground referenced N-channel MOSFET switches B and C.

I_{SSW1} (Pin 18): Forward Current Limit Comparator Non-inverting Input. This pin is normally connected to the source of the N-channel MOSFET A (TG1 driven).

SW1 (Pin 19): Ground Reference for Driver A. Gate drive from TG1 will reference to the common point of output switches A and B.

TG1, TG2 (Pins 20, 12): Top gate drive pins drive the top N-channel MOSFET switches A and D with a voltage swing equal to $V_{CC} - V_{DIODE}$ superimposed on the SW1 and SW2 nodes respectively.

V_{BST1} (Pin 21): Boosted Floating Driver Supply for the Buck Switch A. This pin will swing from a diode below V_{CC} up to $V_{IN} + V_{CC} - V_{DIODE}$.

I_{SVIN} (Pin 22): Forward Current Limit Comparator Inverting Input. This pin is normally connected to the drain of N-channel MOSFET A (TG1 driven).

V_{CC} (Pin 23): Internal 4.5V LDO Regulator Output. The driver and control circuits are powered from this voltage to limit the maximum VGS drive voltage. Decouple this pin to power ground with at least a 4.7 μ F ceramic capacitor. For low V_{IN} applications, V_{CC} can be bootstrapped from V_{OUT} through a Schottky diode.

V_{IN} (Pin 24): Input Supply Pin for the V_{CC} Regulator. A ceramic capacitor of at least 10 μ F is recommended close to the V_{IN} and GND pins.

Exposed Pad (Pin 25): The GND and PGND pins are connected to the Exposed Pad which must be connected to the PCB ground for electrical contact and rated thermal performance.

BLOCK DIAGRAM

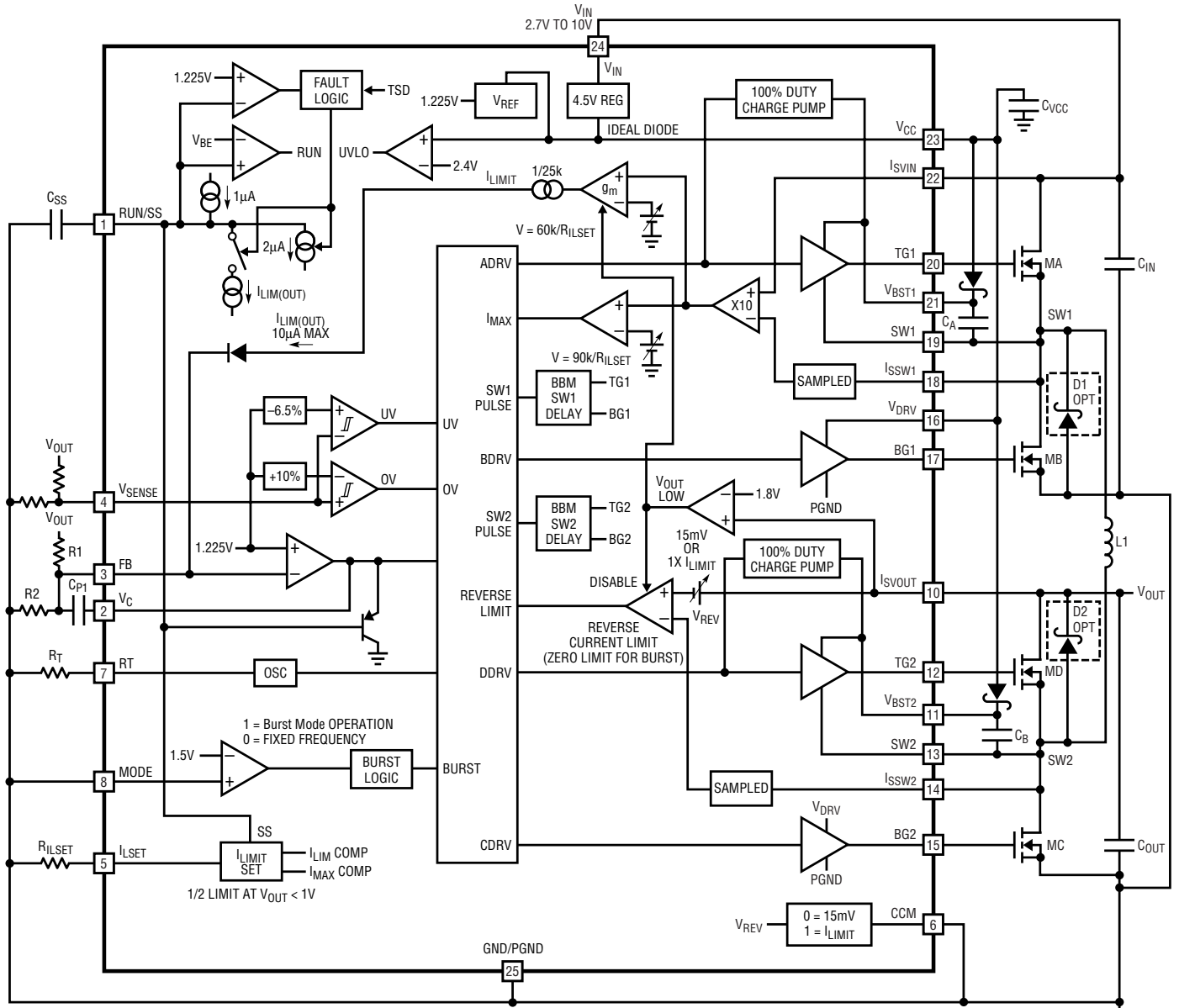

3785 80

OPERATION

MAIN CONTROL LOOP

The LTC3785 is a buck-boost voltage mode controller that provides an output voltage above, equal to or below the input voltage.

The LTC proprietary topology and control architecture also employs drain-to-source sensing (No R_{SENSE}) for forward and reverse current limiting. The controller provides all N-channel MOSFET output switch drive, facilitating single package multiple power switch technology along with lower $R_{DS(ON)}$. The error amp output voltage (V_C) determines the output duty cycle of the switches. Since the V_C pin is a filtered signal, it provides rejection of high frequency noise.

The FB pin receives the voltage feedback signal, which is compared to the internal reference voltage by the error amplifier. The top MOSFET drivers are biased from a floating bootstrap capacitor, which is normally recharged during each off cycle through an external diode when the top MOSFET turns off. Optional Schottky diodes can be connected across synchronous switch B and D to provide a lower drop during the dead time and eliminate efficiency loss due to body diode reverse recovery.

The main control loop is shut down by pulling the RUN/SS pin low. An internal $1\mu A$ current source charges the RUN/SS pin and when the pin voltage is higher than 0.7V the IC is enabled. The V_C voltage is then clamped to the RUN/SS voltage minus 0.7V while C_{SS} is slowly charged during start-up. This “soft-start” clamping prevents inrush current draw from the input power supply.

POWER SWITCH CONTROL

Figure 1 shows a simplified diagram of how the four power switches are connected to the inductor, V_{IN} , V_{OUT} and GND. Figure 2 shows the regions of operation for the LTC3785 as a function of duty cycle D. The power switches are properly controlled so that the transfer between modes is continuous.

Buck Region ($V_{IN} > V_{OUT}$)

Switch D is always on and switch C is always off during buck mode. When the error amp output voltage, V_C , is approximately above 0.1V, output A begins to switch. During

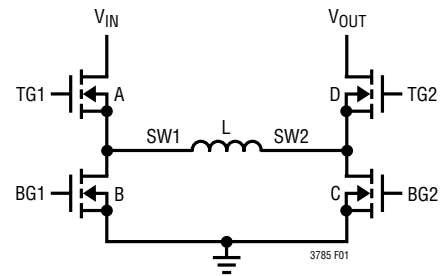

Figure 1. Output Switch Configuration

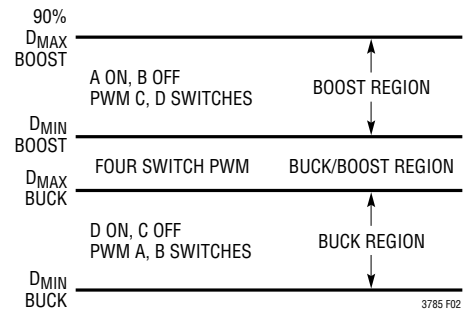

Figure 2. Operation Mode vs V_C Voltage

the off time of switch A, synchronous switch B turns on for the remainder of the switching period. Switches A and B will alternate similar to a typical synchronous buck regulator. As the control voltage increases, the duty cycle of switch A increases until the max duty cycle of the converter in buck mode reaches D_{MAX_BUCK} , given by:

$$D_{MAX_BUCK} = 100 - D4(SW)\%$$

where $D4(SW)$ = duty cycle % of the four switch range.

$$D4(SW) = (300ns \cdot f) \cdot 100\%$$

where f = operating frequency, Hz.

Beyond this point the “four switch” or buck-boost region is reached.

If during the rectification phase (switch pair BD on) the inductor current becomes discontinuous, then switch B is turned off and a damping impedance is connected across the inductor to prevent ringing.

Buck-Boost or Four Switch ($V_{IN} \sim V_{OUT}$)

When the error amp output voltage, V_C , is above approximately 0.65V, switch pair AD remain on for duty cycle D_{MAX_BUCK} , and the switch pair AC begin to phase in. As switch pair AC phases in, switch pair BD phases out

OPERATION

accordingly. When the V_C voltage reaches the edge of the buck-boost range, approximately 0.7V, the AC switch pair completely phase out the BD pair, and the boost phase begins at duty cycle, D4(SW).

The input voltage, V_{IN} , where the four switch region begins is given by:

$$V_{IN} = \frac{V_{OUT}}{1 - (300\text{ns} \cdot f)} V$$

the point at which the four switch region ends is given by:

$$V_{IN} = V_{OUT}(1 - D) = V_{OUT}(1 - 300\text{ns} \cdot f) V$$

If during the rectification phase (switch pair BD on) the inductor current becomes discontinuous, then switch D is turned off and a damping impedance is connected across the inductor to prevent ringing.

Boost Region ($V_{IN} < V_{OUT}$)

Switch A is always on and switch B is always off during boost mode. When the error amp output voltage, V_C , is approximately above 0.7V, switch pair C and D will alternately switch to provide a boosted output voltage. This operation is typical to a synchronous boost regulator. The maximum duty cycle of the converter is limited to 90% typical.

If during the rectification phase (switch pair AD on) the inductor current becomes discontinuous then switch D is turned off and a damping impedance is connected across the inductor to prevent ringing.

Burst Mode OPERATION

During Burst Mode operation, the LTC3785 delivers energy to the output until it is regulated and then goes into a sleep state where the outputs are off and the IC is consuming only 86 μ A. In Burst Mode operation, the output ripple has a variable frequency component, which is dependent upon load current

During the period where the converter is delivering energy to the output, the inductor will reach a peak current

determined by an on time, t_{ON} , and will terminate at zero current for each cycle. The on time is given by:

$$t_{ON} = \frac{2.4}{V_{IN} \cdot f}$$

where f is the oscillator frequency.

The peak current is given by:

$$I_{PEAK} = \frac{V_{IN}}{L} \cdot t_{ON}$$

$$I_{PEAK} = \frac{2.4}{f \cdot L}$$

So the peak current is independent of V_{IN} and inversely proportional to the $f \cdot L$ product optimizing the energy transfer for various applications.

In Burst Mode operation the maximum output current is given by:

$$I_{OUT(MAX,BURST)} \approx \frac{1.2 \cdot V_{IN}}{f \cdot L \cdot (V_{OUT} + V_{IN})} A$$

Burst Mode operation is user-controlled by driving the MODE pin high to enable and low to disable.

V_{CC} REGULATOR

An internal P-channel low dropout regulator produces 4.35V at the V_{CC} pin from the V_{IN} supply pin. V_{CC} powers the drivers and internal circuitry of the LTC3785. The V_{CC} pin regulator can supply a peak current of 100mA and must be bypassed to ground with a minimum of 4.7 μ F placed directly adjacent to the V_{CC} and GND pins. Good bypassing is necessary to supply the high transient current required by the MOSFET gate drivers and to prevent interaction between channels. If desired, the V_{CC} regulator can be connected to V_{OUT} through a Schottky diode to provide higher gate drive in low input voltage applications. The V_{CC} regulator can also be driven with an external 5V source directly (without a Schottky diode).

OPERATION

TOPSIDE MOSFET DRIVER SUPPLY (V_{BST1} , V_{BST2})

The external bootstrap capacitors connected to the V_{BST1} and V_{BST2} pins supply the gate drive voltage for the top-side MOSFET switches A and D. When the top MOSFET switch A turns on, the switch node SW1 rises to V_{IN} and the V_{BST2} pin rises to approximately $V_{IN} + V_{CC}$. When the bottom MOSFET switch B turns on, the switch node SW1 drops low and the boost capacitor is charged through the diode connected to V_{CC} . When the top MOSFET switch D turns on, the switch node SW2 rises to V_{OUT} and the V_{BST2} pin rises to approximately $V_{OUT} + V_{CC}$. When the bottom MOSFET switch C turns on, the switch node SW2 drops low and the boost capacitor is charged through the diode connected to V_{CC} . The boost capacitors need to store about 100 times the gate charge required by the top MOSFET switch A and D. In most applications a 0.1 μ F to 0.47 μ F, X5R or X7R dielectric capacitor is adequate.

RUN/SOFT-START (RUN/SS)

The RUN/SS pin serves as the enable to the LTC3785, soft-start function, and fault programming. A 1 μ A current source charges the external capacitor. Once the RUN/SS voltage is above a diode drop (~0.7V) the IC is enabled. Once the IC is enabled, the RUN/SS voltage minus a diode drop (RUN/SS – 0.7V) clamps the output of the error amp (V_C) to limit duty cycle. The range of the duty cycle clamping is approximately 0.7V to 1.7V. The RUN/SS pin is clamped to approximately 2.2V. If current limit is reached the pin will begin to discharge with a current determined by the magnitude of inductor current overcurrent limit, but not to exceed 10 μ A. This function will be described in more detail in the “Forward Current Limit” section.

OSCILLATOR

The frequency of operation is set through a resistor from the RT pin to ground where $f \approx (2.5e^{10}/RT)$ Hz.

ERROR AMP

The error amplifier is a voltage mode amplifier with a reference voltage of 1.225V internally connected to the non-inverting input. The loop compensation components

are configured around the amplifier to provide loop compensation for the converter. The RUN/SS pin will clamp the error amp output, V_C , to provide a soft-start function.

UNDERVOLTAGE AND OVERVOLTAGE PROTECTION

The LTC3785 incorporates overvoltage (OV) and undervoltage (UV) functions for fault protection and transient limitation. Both comparators are connected to the V_{SENSE} pin, which usually has a similar voltage divider as the error amplifier without the compensation. The overvoltage threshold is 10% above the reference. The undervoltage threshold is 6.5% below the reference with both comparators having 1% hysteresis. During an overvoltage fault, all output switching stops until the fault ceases. During an undervoltage fault, the IC is commanded to run fixed frequency only (disabled Burst Mode operation). If the design requires a tightened threshold to one of the comparator thresholds the voltage divider on the V_{SENSE} pin can be skewed to achieve the threshold. Since the range is a constant, tightening the UV threshold will loosen the OV threshold and vice versa.

FORWARD CURRENT LIMIT

The LTC3785 is designed to sense the input current by sampling the voltage across MOSFET A during the on time of the switch (TG1 = High). The sense pins are I_{SVIN} and I_{SSW1} . A current sense resistor can be used if increased accuracy is required. The current limit threshold can be programmed with a resistor on the I_{LSET} pin. Once the desired current limit has been chosen, R_{ILSET} can be determined by the following formula:

$$R_{ILSET} = \frac{6000}{R_{DS(ON)A} \cdot I_{LIMIT}} \Omega$$

where $R_{DS(ON)A} = R_{DS(ON)}$ of N-channel MOSFET switch A and I_{LIMIT} = current limit in Amps.

Once the voltage between I_{SVIN} and I_{SSW1} exceeds the threshold, current will be sourced out of FB to take control of the voltage loop, resulting in a lower output voltage to regulate the input current. This fault condition causes the RUN/SS capacitor to begin discharging. The level of

OPERATION

the discharge current depends on how much the current exceeds the programmed threshold. Figure 3 is a simplified diagram of the current sense and fault circuitry. If the current limit fault duration is long enough to discharge the RUN/SS capacitor below 1.225V, the fault latch is set and will cycle the RUN/SS capacitor 16 times ($1\mu\text{A}$ charging and $1\mu\text{A}$ discharging of the RUN/SS capacitor) to create an off time of 32 times the soft-start time before the outputs are allowed to switch to restart the output voltage. If the current limit fault level exceeds 150% of the programmed I_{LIMIT} level at any time, the I_{MAX} comparator is tripped and output switches B and D are turned on to discharge the inductor current for the remainder of the cycle.

To have the power converter latch-off on a fault, a pull-up current between $4\mu\text{A}$ and $7\mu\text{A}$ on the RUN/SS pin will allow the RUN/SS capacitor to discharge during an extended fault, but will prevent cycling of the fault which will cause the converter to stay off. One method to implement this is by placing a diode (anode tied to V_{OUT}) and a resistor from V_{OUT} to the RUN/SS pin. The current sourced into RUN/SS will be

$V_{\text{OUT}} - 0.7$ divided by the resistor value. To ignore all faults source greater than $40\mu\text{A}$ into the RUN/SS pin (At 1.225V on the RUN/SS pin). Since the maximum fault current is limited, this will prevent any discharging of the RUN/SS capacitor, the soft-start capacitor will need to be sized accordingly to accommodate the extra charging current at start-up.

During an output short-circuit or if V_{OUT} is less than 1.8V, the current limit folds back to 50% of the programmed level.

REVERSE CURRENT LIMIT

The LTC3785 can be programmed to provide full class D operation or allowed to source and sink current equal to the current limit set value. This is achieved by asserting a high level on the CCM pin. To minimize the reverse output current, the CCM pin should be driven low or strapped to ground. During this mode only, -15mV typical is allowed across output switch D and is sensed with the I_{SVOUT} and I_{SSW2} pins.

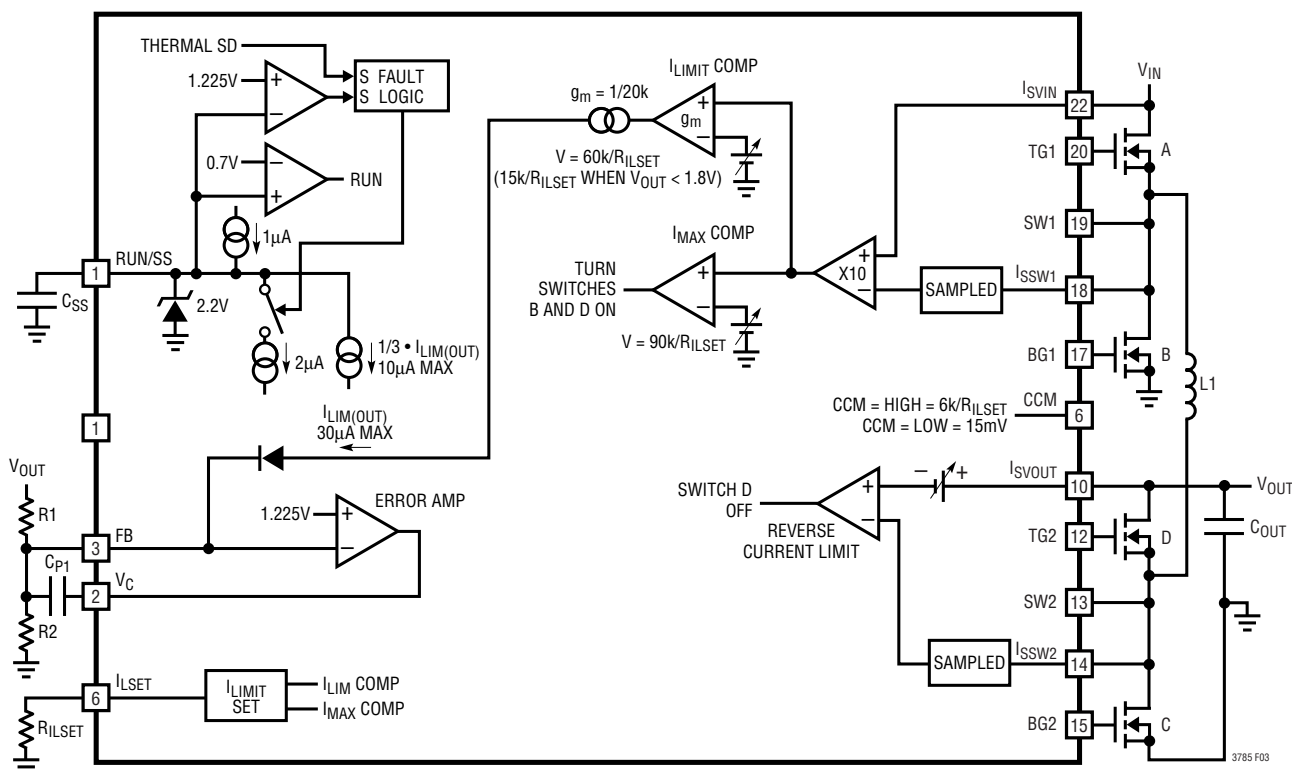

Figure 3. Block Diagram of Current Limit Fault Circuitry

APPLICATIONS INFORMATION

INDUCTOR SELECTION

The high frequency operation of the LTC3785 allows the use of small surface mount inductors. The inductor current ripple is typically set 20% to 40% of the maximum inductor current. For a given ripple the inductance terms are given as follows:

$$L > \frac{V_{IN(MIN)}^2 \cdot (V_{OUT} - V_{IN(MIN)}) \cdot 100}{f \cdot I_{OUT(MAX)} \cdot \%Ripple \cdot V_{OUT}^2}, \text{ (Boost Mode)}$$

$$L > \frac{V_{OUT} \cdot (V_{IN(MAX)} - V_{OUT}) \cdot 100}{f \cdot I_{OUT(MAX)} \cdot \%Ripple \cdot V_{IN(MAX)}}, \text{ (Buck Mode)}$$

where:

f = Operating frequency, Hz

%Ripple = Allowable inductor current ripple, %

$V_{IN(MIN)}$ = Minimum input voltage (limit to $V_{OUT}/2$ minimum for worst case), V

$V_{IN(MAX)}$ = Maximum input voltage, V

V_{OUT} = Output voltage, V

$I_{OUT(MAX)}$ = Maximum output load current, A

For high efficiency choose an inductor with a high frequency core material, such as ferrite, to reduce core losses. The inductor should have low ESR (equivalent series resistance) to reduce the I^2R losses, and must be able to handle the peak inductor current without saturating. Molded chokes or chip inductors usually do not have enough core to support the peak inductor currents in the 3A to 6A region. To minimize radiated noise, use a toroid, pot core or shielded bobbin inductor.

C_{IN} AND C_{OUT} SELECTION

In boost mode, input current is continuous. In buck mode, input current is discontinuous. In buck mode, the selection of input capacitor, C_{IN} , is driven by the need to filter the input square wave current. Use a low ESR capacitor, sized to handle the maximum RMS current. For buck operation, the maximum RMS capacitor current is given by:

$$I_{RMS} \sim I_{OUT(MAX)} \cdot \sqrt{\frac{V_{OUT}}{V_{IN}} \cdot \left(1 - \frac{V_{OUT}}{V_{IN}}\right)}$$

This formula has a maximum at $V_{IN} = 2V_{OUT}$, where $I_{RMS} = I_{OUT(MAX)}/2$. This simple worst-case condition is commonly used for design because even significant deviations do not offer much relief. Note that ripple current ratings from capacitor manufacturers are often based on only 2000 hours of life which makes it advisable to derate the capacitor. In boost mode, the discontinuous current shifts from the input to the output, so C_{OUT} must be capable of reducing the output voltage ripple. The effects of ESR (equivalent series resistance) and the bulk capacitance must be considered when choosing the right capacitor for a given output ripple voltage. The steady ripple due to charging and discharging the bulk capacitance is given by:

$$V_{RIPPLE_BOOST} = \frac{I_{OUT(MAX)} \cdot (V_{OUT} - V_{IN(MIN)})}{C_{OUT} \cdot V_{OUT} \cdot f}$$

$$V_{RIPPLE_BUCK} = \frac{V_{OUT} \cdot (V_{IN(MAX)} - V_{OUT})}{8 \cdot L \cdot C_{OUT} \cdot V_{IN(MAX)} \cdot f^2}$$

where C_{OUT} = output filter capacitor, F

The steady ripple due to the voltage drop across the ESR is given by:

$$\Delta V_{BOOST,ESR} = I_{L(MAX,BOOST)} \cdot ESR$$

$$\Delta V_{BUCK,ESR} = \frac{(V_{IN(MAX)} - V_{OUT}) \cdot V_{OUT}}{L \cdot f \cdot V_{IN}} \cdot ESR$$

Multiple capacitors placed in parallel may be needed to meet the ESR and RMS current handling requirements. Dry tantalum, special polymer, aluminum electrolytic and ceramic capacitors are all available in surface mount packages. Ceramic capacitors have excellent low ESR characteristics but can have a high voltage coefficient. Capacitors are now available with low ESR and high ripple current ratings such as OS-CON and POSCAP.

POWER N-CHANNEL MOSFET SELECTION AND EFFICIENCY CONSIDERATIONS

The LTC3785 requires four external N-channel power MOSFETs, two for the top switches (switches A and D, shown in Figure 1) and two for the bottom switches (switches B and C shown in Figure 1). Important parameters for the power MOSFETs are the breakdown voltage

APPLICATIONS INFORMATION

$V_{BR(DSS)}$, threshold voltage $V_{GS(TH)}$, on-resistance $R_{DS(ON)}$, reverse transfer capacitance C_{RSS} and maximum current $I_{DS(MAX)}$. The drive voltage is set by the 4.5V V_{CC} supply. Consequently, logic-level threshold MOSFETs must be used in LTC3785 applications. If the input voltage is expected to drop below 5V, then sub-logic threshold MOSFETs should be considered. In order to select the power MOSFETs, the power dissipated by the device must be known.

For switch A, the maximum power dissipation happens in boost mode, when it remains on all the time. Its maximum power dissipation at maximum output current is given by:

$$PA(BOOST) = \left(\frac{V_{OUT}}{V_{IN}} \cdot I_{OUT(MAX)} \right)^2 \cdot \rho T \cdot R_{DS(ON)}$$

where ρT is a normalization factor (unity at 25°C) accounting for the significant variation in on-resistance with temperature, typically about 0.4%/°C as shown in Figure 4. For a maximum junction temperature of 125°C, using a value $\rho T = 1.5$ is reasonable.

Switch B operates in buck mode as the synchronous rectifier. Its power dissipation at maximum output current is given by:

$$PB(BUCK) = \frac{V_{IN} - V_{OUT}}{V_{IN}} \cdot I_{OUT(MAX)} \cdot \rho T \cdot R_{DS(ON)}$$

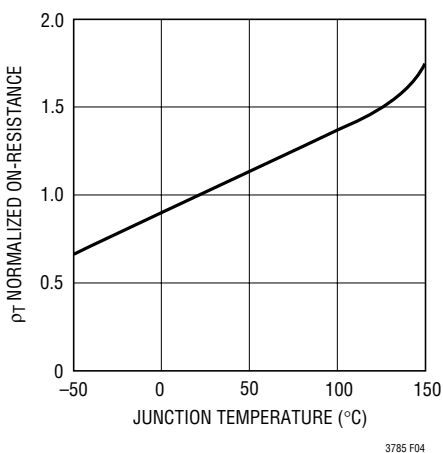

Figure 4. Normalized $R_{DS(ON)}$ vs Temperature

Switch C operates in boost mode as the control switch. Its power dissipation at maximum current is given by:

$$PC(BOOST) = \frac{(V_{OUT} - V_{IN}) \cdot V_{OUT}}{V_{IN}^2} \cdot I_{OUT(MAX)}^2 \cdot \rho T \cdot R_{DS(ON)} + k \cdot V_{OUT}^3 \cdot \frac{I_{OUT(MAX)}}{V_{IN}} \cdot C_{RSS} \cdot f$$

where C_{RSS} is usually specified by the MOSFET manufacturers. The constant k , which accounts for the loss caused by reverse recovery current, is inversely proportional to the gate drive current and has an empirical value of 1.0.

For switch D, the maximum power dissipation happens in boost mode when its duty cycle is higher than 50%. Its maximum power dissipation at maximum output current is given by:

$$PD(BOOST) = \frac{V_{OUT}}{V_{IN}} \cdot I_{OUT(MAX)}^2 \cdot \rho T \cdot R_{DS(ON)}$$

Typically, switch A has the highest power dissipation and switch B has the lowest power dissipation unless a short occurs at the output. From a known power dissipated in the power MOSFET, its junction temperature can be obtained using the following formula:

$$T_J = T_A + P \cdot R_{TH(JA)}$$

The $R_{TH(JA)}$ to be used in the equation normally includes the $R_{TH(JC)}$ for the device plus the thermal resistance from the case to the ambient temperature ($R_{TH(CA)}$). This value of T_J can then be compared to the original, assumed value used in the iterative calculation process.

SCHOTTKY DIODE (D1, D2) SELECTION

Optional Schottky diodes D1 and D2 shown in the Block Diagram conduct during the dead time between the conduction of the power MOSFET switches. They are intended to prevent the body diode of synchronous switches B and D from turning on and storing charge during the dead time. In particular, D2 significantly reduces reverse recovery current between switch D turn off and switch C turn on, which improves converter efficiency and reduces switch C voltage stress. In order for D2 to be effective, it must be located in very close proximity to SWD.

APPLICATIONS INFORMATION

CLOSING THE FEEDBACK LOOP

The LTC3785 incorporates voltage mode control. The control to output gain is given by:

$$G_{\text{BUCK}} = 1.6 \cdot V_{\text{IN}}, \text{ Buck Mode}$$

$$G_{\text{BOOST}} = \frac{1.6 \cdot V_{\text{OUT}}^2}{V_{\text{IN}}}, \text{ Boost Mode}$$

The output filter exhibits a double-pole response and is given by:

$$f_{\text{FILTER_POLE}} = \frac{1}{2 \cdot \pi \cdot \sqrt{L \cdot C_{\text{OUT}}}}$$

where C_{OUT} is the output filter capacitor.

The output filter zero is given by:

$$f_{\text{FILTER_ZERO}} = \frac{1}{2 \cdot \pi \cdot R_{\text{ESR}} \cdot C_{\text{OUT}}}$$

where R_{ESR} is the capacitor equivalent series resistance.

A troublesome feature in boost mode is the right half plane zero (RHP), and is given by:

$$f_{\text{RHPZ}} = \frac{V_{\text{IN}}^2}{2 \cdot \pi \cdot I_{\text{OUT}} \cdot L \cdot V_{\text{OUT}}}$$

The loop gain is typically rolled off before the RHP zero frequency.

A simple type I compensation network (Figure 5) can be incorporated to stabilize the loop but at a cost of reduced bandwidth and slower transient response. To ensure proper phase margin, the loop must cross over almost a decade before the L-C double pole.

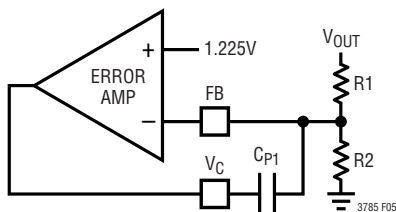

Figure 5. Error Amplifier with Type I Compensation

The unity gain frequency of the error amplifier with the type 1 compensation is given by:

$$f_{\text{UG}} = \frac{1}{2 \cdot \pi \cdot R_1 \cdot C_{\text{P1}}}$$

Most applications demand an improved transient response to allow a smaller output filter capacitor. To achieve a higher bandwidth, type III compensation is required as shown in Figure 6. Two zeros are required to compensate for the double pole response.

$$f_{\text{POLE1}} \approx \frac{1}{2 \cdot \pi \cdot 32e3 \cdot C_{\text{P1}} \cdot R_1} \text{ (a very low frequency)}$$

$$f_{\text{ZERO1}} = \frac{1}{2 \cdot \pi \cdot R_Z \cdot C_{\text{P1}}}$$

$$f_{\text{ZERO2}} = \frac{1}{2 \cdot \pi \cdot R_1 \cdot C_{\text{Z1}}}$$

$$f_{\text{POLE2}} \approx \frac{1}{2 \cdot \pi \cdot R_Z \cdot C_{\text{P2}}}$$

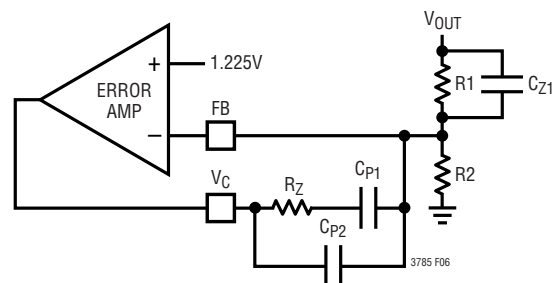

Figure 6. Error Amplifier with Type III Compensation

EFFICIENCY CONSIDERATIONS

The percentage efficiency of a switching regulator is equal to the output power divided by the input power times 100%.

It is often useful to analyze individual losses to determine what is limiting the efficiency and which change would produce the most improvement. Although all dissipative elements in circuits produce losses, four main sources account for most of the losses in LTC3785 application circuits:

APPLICATIONS INFORMATION

1. DC I^2R losses. These arise from the resistances of the MOSFETs, sensing resistor (if used), inductor and PC board traces and cause the efficiency to drop at high output currents.
2. Transition loss. This loss arises from the brief voltage transition time of switch A or switch C. It depends upon the switch voltage, inductor current, driver strength and MOSFET capacitance, among other factors.

$$\text{Transition Loss} \sim V_{\text{SW}}^2 \cdot I_L \cdot C_{\text{RSS}} \cdot f$$

where C_{RSS} is the reverse transfer capacitance.

3. C_{IN} and C_{OUT} loss. The input capacitor has the difficult job of filtering the large RMS input current to the regulator in buck mode. The output capacitor has the more difficult job of filtering the large RMS output current in boost mode. Both C_{IN} and C_{OUT} are required to have low ESR to minimize the AC I^2R loss and sufficient capacitance to prevent the RMS current from causing additional upstream losses in fuses or batteries.
4. Other losses. Optional Schottky diodes D1 and D2 are responsible for conduction losses during dead time and light load conduction periods. Core loss is the predominant inductor loss at light loads. Turning on switch C causes reverse recovery current loss in boost mode. When making adjustments to improve efficiency, the input current is the best indicator of changes in efficiency. If you make a change and the input current decreases, then the efficiency has increased. If there is no change in input current, then there is no change in efficiency.
5. V_{CC} regulator loss. In applications where the input voltage is above 5V, such as two Li-Ion cells, the V_{CC} regulator will dissipate some power due the differential voltage and the average output current to the drive the gates of the output switches. The V_{CC} pin can be driven directly from a high efficiency external 5V source if desired to incrementally improve overall efficiency at lighter loads.

DESIGN EXAMPLE

As a design example, assume $V_{\text{IN}} = 2.7\text{V}$ to 10V (3.6V nominal Li-Ion with 9V adapter), $V_{\text{OUT}} = 3.3\text{V}$ (5%), $I_{\text{OUT(MAX)}} = 3\text{A}$ and $f = 500\text{kHz}$.

Determine the Inductor Value

Setting the Inductor Ripple to 40% and using the equations in the Inductor Selection section gives:

$$L > \frac{(2.7)^2 \cdot (3.3 - 2.7) \cdot 100}{500 \cdot 10^3 \cdot 3 \cdot 40 \cdot (3.3)^2} = 0.67\mu\text{H}$$

$$L > \frac{3.3 \cdot (10 - 3.3) \cdot 100}{500 \cdot 10^3 \cdot 3 \cdot 40 \cdot 10} = 3.7\mu\text{H}$$

So the worst-case ripple for this application is during buck mode so a standard inductor value of 3.3 μH is chosen.

Determine the Proper Inductor Type Selection

The highest inductor current is during boost mode and is given by:

$$I_{\text{L(MAX_AV)}} = \frac{V_{\text{OUT}} \cdot I_{\text{OUT}}}{V_{\text{IN}} \cdot \eta}$$

where η = estimated efficiency in this mode (use 80%).

$$I_{\text{L(MAX_AV)}} = \frac{3.3 \cdot 3}{2.7 \cdot 0.8} = 4.6\text{A}$$

To limit the maximum efficiency loss of the inductor ESR to below 5% the equation is:

$$\text{ESR}_{\text{L(MAX)}} \sim \frac{V_{\text{OUT}} \cdot I_{\text{OUT}} \cdot \% \text{Loss}}{I_{\text{L(MAX_AV)}}^2 \cdot 100} = 24\text{m}\Omega$$

A suitable inductor for this application could be a Coiltronics CD1-3R8 which has a rating DC current of 6A and ESR of 13m Ω .

Choose a Proper MOSFET Switch

Using the same guidelines for ESR of the inductor, one suitable MOSFET could be the Siliconix Si7940DP which is a dual MOSFET in a surface mount package with 25m Ω at 2.5V and a total gate charge of 12nC.

Checking the power dissipation of each switch will ensure reliable operation since the thermal resistance of the package is 60 $^{\circ}\text{C}/\text{W}$.

APPLICATIONS INFORMATION

The maximum power dissipation of switch A and C occurs in boost mode. Assuming a junction temperature of $T_J = 100^\circ\text{C}$ with $\rho_{100^\circ\text{C}} = 1.3$, the power dissipation at $V_{IN} = 2.7$, and using the equations from the Efficiency Considerations section:

$$PA(\text{BOOST}) = \left(\frac{3.3}{2.7} \cdot 3\right)^2 \cdot 1.3 \cdot 0.025 = 0.43\text{W}$$

$$PC(\text{BOOST}) = \frac{(3.3 - 2.7) \cdot 3.3}{2.7^2} \cdot 3^2 \cdot 1.3 \cdot 0.025$$

$$+ 1 \cdot 3.3^3 \cdot \frac{3}{2.7} \cdot 0.45 - 9 \cdot 500 \cdot 10^3$$

$$= 0.09\text{W}$$

The maximum power dissipation of switch B and D occurs in buck mode and is given by:

$$PB(\text{BUCK}) = \frac{10 - 3.3}{10} \cdot 3^2 \cdot 1.3 \cdot 0.025 = 0.20\text{W}$$

$$PD(\text{BOOST}) = \frac{3.3}{10} \cdot 3^2 \cdot 1.3 \cdot 0.025 = 0.10\text{W}$$

Now to double check the T_J of the package with 50°C ambient. Since this is a dual NMOS package we can add switches A + B and C + D worst case. For applications where the MOSFETs are in separate packages each device's maximum T_J would have to be calculated.

$$T_{J(\text{PKG1})} = T_A + \theta_{JA}(PA + PB)$$

$$= 50 + 60 \cdot (0.43 + 0.20) = 88^\circ\text{C}$$

$$T_{J(\text{PKG2})} = T_A + \theta_{JA}(PC + PD)$$

$$= 50 + 60 \cdot (0.09 + 0.10) = 60^\circ\text{C}$$

Set The Maximum Current Limit

The equation for setting the maximum current limit of the IC is given by:

$$R_{ILSET} = \frac{6e3}{R_{DS(ON)A} \cdot I_{LIMIT}} \Omega$$

The maximum current is set 25% above $I_{L(\text{PEAK})}$ to account for worst-case variation at $100^\circ\text{C} = 6\text{A}$.

$$R_{ILSET} = \frac{6e3}{0.025 \cdot 6} = 42\text{k}$$

Choose the Input and Output Capacitance

The input capacitance should filter current ripple which is worst case in buck mode. Since the input current could reach 6A, a capacitor ESR of $10\text{m}\Omega$ or less will yield an input ripple of 60mV.

The output capacitance should filter current ripple which is worst in boost mode, but is usually dictated by the loop response, the maximum load transient and the allowable transient response.

PC BOARD LAYOUT CHECKLIST

The basic PC board layout requires a dedicated ground plane layer. Also, for high current, a multilayer board provides heat sinking for power components.

- The ground plane layer should not have any traces and it should be as close as possible to the layer with power MOSFETs.
- Place C_{IN} , switch A, switch B and D1 in one compact area. Place C_{OUT} , switch C, switch D and D2 in one compact area.
- Use immediate vias to connect the components (including the LTC3785's GND/PGND pin) to the ground plane. Use several large vias for each power component.
- Use planes for V_{IN} and V_{OUT} to maintain good voltage filtering and to keep power losses low.
- Flood all unused areas on all layers with copper. Flooding with copper will reduce the temperature rise of power components. Connect the copper areas to any DC net (V_{IN} or GND). When laying out the printed circuit board, the following checklist should be used to ensure proper operation of the LTC3785.

APPLICATIONS INFORMATION

- Segregate the signal and power grounds. All small-signal components should return to the GND pin at one point. The sources of switch B and switch C should also connect to one point at the GND of the IC.
- Place switch B and switch C as close to the controller as possible, keeping the PGND, BG and SW traces short.
- Keep the high dV/dT SW1, SW2, V_{BST1} , V_{BST2} , TG1 and TG2 nodes away from sensitive small-signal nodes.
- The path formed by switch A, switch B, D1 and the C_{IN} capacitor should have short leads and PC trace lengths. The path formed by switch C, switch D, D2 and the C_{OUT} capacitor also should have short leads and PC trace lengths.
- The output capacitor (–) terminals should be connected as close as possible to the (–) terminals of the input capacitor.
- Connect the V_{CC} decoupling capacitor C_{VCC} closely to the V_{CC} and PGND pins.
- Connect the top driver boost capacitor C_A closely to the V_{BST1} and SW1 pins. Connect the top driver boost capacitor C_B closely to the V_{BST2} and SW2 pins.
- Connect the input capacitors C_{IN} and output capacitors C_{OUT} close to the power MOSFETs. These capacitors carry the MOSFET AC current in boost and buck mode.
- Connect FB and V_{SENSE} pin resistive dividers to the (+) terminals of C_{OUT} and signal ground. If a small V_{SENSE} decoupling capacitor is used, it should be as close as possible to the LTC3785 GND pin.
- Route I_{SVIN} and I_{SSW1} leads together with minimum PC trace spacing. Ensure accurate current sensing with Kelvin connections across MOSFET A or sense resistor.
- Route I_{SVOUT} and I_{SSW2} leads together with minimum PC trace spacing. Ensure accurate current sensing with Kelvin connections across MOSFET D or sense resistor.
- Connect the feedback network close to IC, between the V_C and FB pins.

TYPICAL APPLICATION

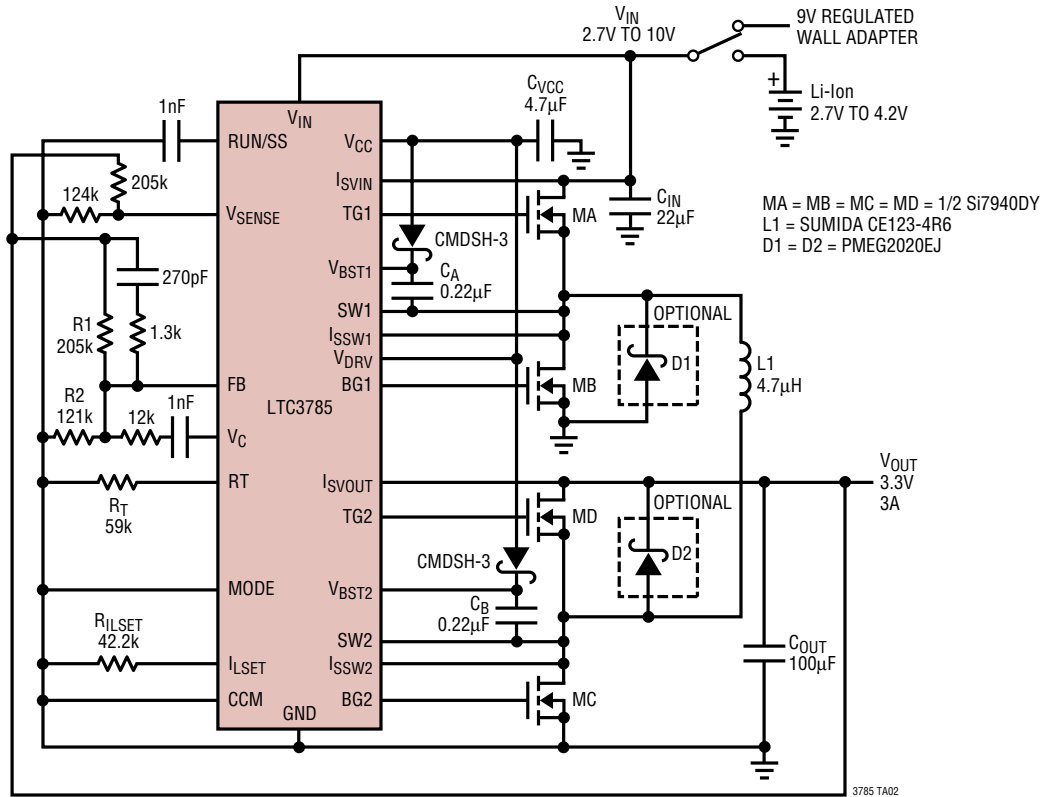

PACKAGE DESCRIPTION

UF Package
24-Lead Plastic QFN (4mm × 4mm)
(Reference LTC DWG # 05-08-1697)

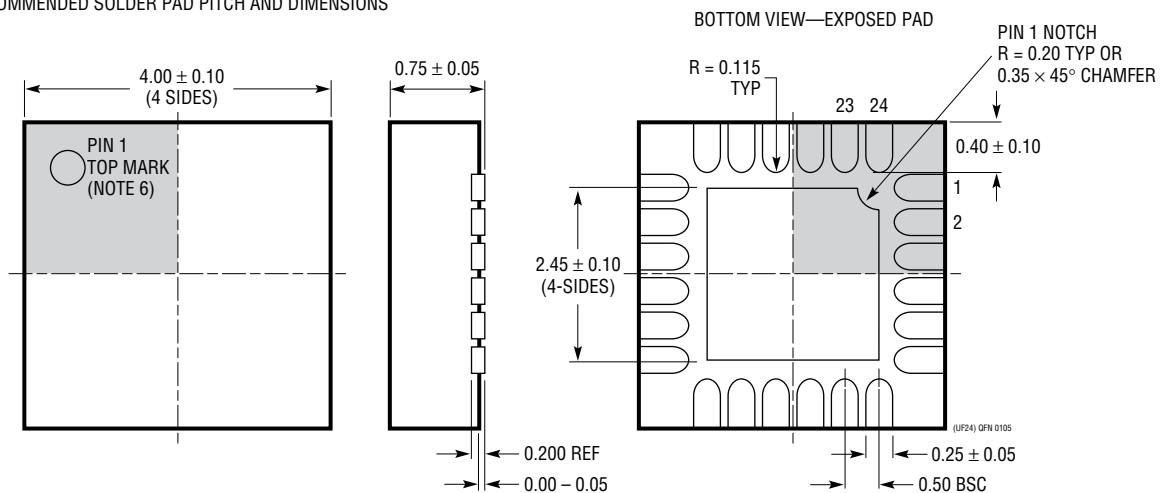
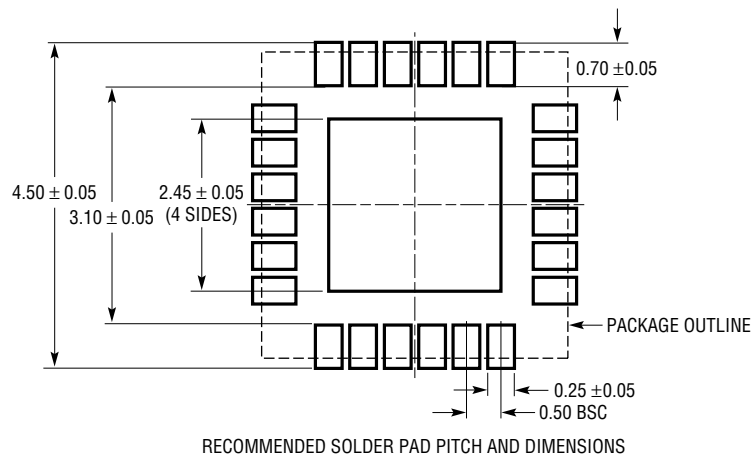

NOTE:

1. DRAWING PROPOSED TO BE MADE A JEDEC PACKAGE OUTLINE MO-220 VARIATION (WGGD-X)—TO BE APPROVED
2. DRAWING NOT TO SCALE
3. ALL DIMENSIONS ARE IN MILLIMETERS
4. DIMENSIONS OF EXPOSED PAD ON BOTTOM OF PACKAGE DO NOT INCLUDE MOLD FLASH. MOLD FLASH, IF PRESENT, SHALL NOT EXCEED 0.15mm ON ANY SIDE, IF PRESENT
5. EXPOSED PAD SHALL BE SOLDER PLATED
6. SHADED AREA IS ONLY A REFERENCE FOR PIN 1 LOCATION ON THE TOP AND BOTTOM OF PACKAGE

TYPICAL APPLICATION

Li-Ion/9V Wall Adapter to 5V/2A

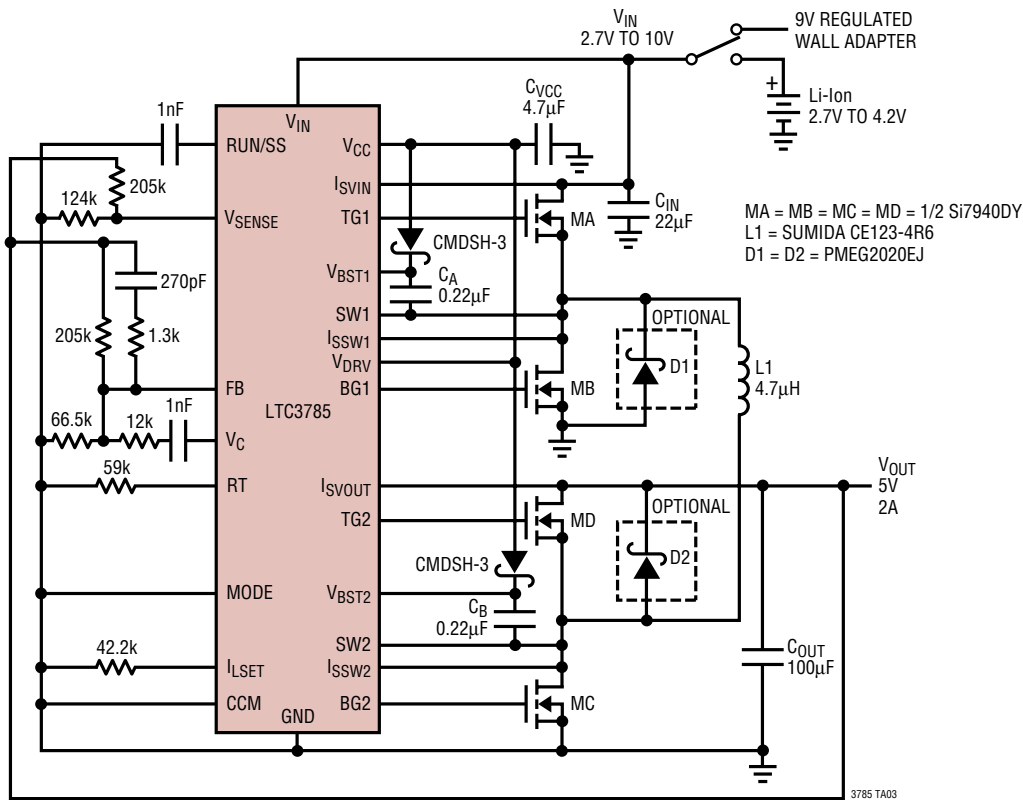

3785 TA03

RELATED PARTS

PART NUMBER	DESCRIPTION	COMMENTS
LTC3440	600mA I_{OUT} , 2MHz, Synchronous Buck-Boost DC/DC Converter	V_{IN} : 2.5V to 5.5V, V_{OUT} : 2.5V to 5.5V, I_Q = 25µA, I_{SD} < 1µA, MS, DFN Packages
LTC3441	1.2A I_{OUT} , 1MHz, Synchronous Buck-Boost DC/DC Converter	V_{IN} : 2.4V to 5.5V, V_{OUT} : 2.4V to 5.25V, I_Q = 25µA, I_{SD} < 1µA, DFN Package
LTC3442	1.2A I_{OUT} , 2MHz, Synchronous Buck-Boost DC/DC Converter	V_{IN} : 2.4V to 5.5V, V_{OUT} : 2.4V to 5.25V, I_Q = 35µA, I_{SD} < 1µA, DFN Package
LTC3443	1.2A I_{OUT} , 600kHz, Synchronous Buck-Boost DC/DC Converter	V_{IN} : 2.4V to 5.5V, V_{OUT} : 2.4V to 5.25V, I_Q = 28µA, I_{SD} < 1µA, MS Package
LTC3444	500mA I_{OUT} , 1.5MHz Synchronous Buck-Boost DC/DC Converter	V_{IN} : 2.7V to 5.5V, V_{OUT} : 0.5V to 5.25V, Optimized for WCDMA RF Amplifier Bias
LTC3531 LTC3531-3 LTC3531-3.3	200mA I_{OUT} , Synchronous Buck-Boost DC/DC Converter	V_{IN} : 1.8V to 5.5V, V_{OUT} : 2V to 5V, I_Q = 35µA, I_{SD} < 1µA, MS, DFN Packages
LTC3532	500mA I_{OUT} , 2MHz, Synchronous Buck-Boost DC/DC Converter	V_{IN} : 2.4V to 5.5V, V_{OUT} : 2.4V to 5.25V, I_Q = 35µA, I_{SD} < 1µA, MS, DFN Packages
LTC3533	2A Wide Input Voltage Synchronous Buck-Boost DC/DC Converter	V_{IN} : 1.8V to 5.5V, V_{OUT} : 1.8V to 5.25V, I_Q = 40µA, I_{SD} < 1µA, DFN Package
LTC3780	High Efficiency, Synchronous, 4-Switch Buck-Boost Controller	V_{IN} : 4V to 36V, V_{OUT} : 0.8V to 30V, I_Q = 1.5mA, I_{SD} < 55µA, SSOP-24, QFN-32 Packages

3785F