

Single-Phase, High Efficiency DC/DC Controller for Intel Mobile CPUs

FEATURES

- **Wide Input Voltage Range: 4V to 30V**
- **±1% Output Voltage Accuracy**
- **6-Bit IMVP-IV VID Code: $V_{OUT} = 0.7V$ to $1.708V$**
- **Intel Compatible Power Saving Mode (PSIB)**
- **Power Good Output with Adaptive Masking**
- **Lossless Voltage Positioning**
- **Resistor Programmable V_{OUT} at Boot-Up and Deeper Sleep State**
- Resistor Programmable Deep Sleep Offset
- Programmable Fixed Frequency: 210kHz to 550kHz
- Adjustable Soft-Start Current Ramping
- Foldback Output Current Limit
- Short-Circuit Shutdown Timer with Defeat Option
- Overvoltage Protection
- Available in 32-Lead 5mm × 5mm × 0.8mm (Profile) QFN Package

APPLICATIONS

- Mobile and Desktop Computers
- Internet Servers

DESCRIPTION

The LTC[®]3734 is a single-phase synchronous step-down switching regulator controller that drives all N-channel power MOSFETs in a constant frequency architecture. The output voltage is programmable by six VID bits during normal operation and by external resistors during initial boot-up and deeper sleep state. The LTC3734 drives its output stage at frequencies up to 550kHz. Powerful on-chip gate drivers eliminate the need for external gate driver ICs, thus simplifying the design.

An Intel compatible PSIB input is provided to select between two modes of operation. Fully enhanced synchronous mode achieves a very small output ripple and very fast transient response while power saving mode realizes very high efficiency. OPTI-LOOP[®] compensation allows the transient response to be optimized for a wide range of output capacitance and ESR values.

The LTC3734 is available in a small 5mm × 5mm QFN package. For 2-phase applications refer to the LTC3735.

 LTC and LT are registered trademarks of Linear Technology Corporation. OPTI-LOOP is a registered trademark of Linear Technology Corporation.

TYPICAL APPLICATION

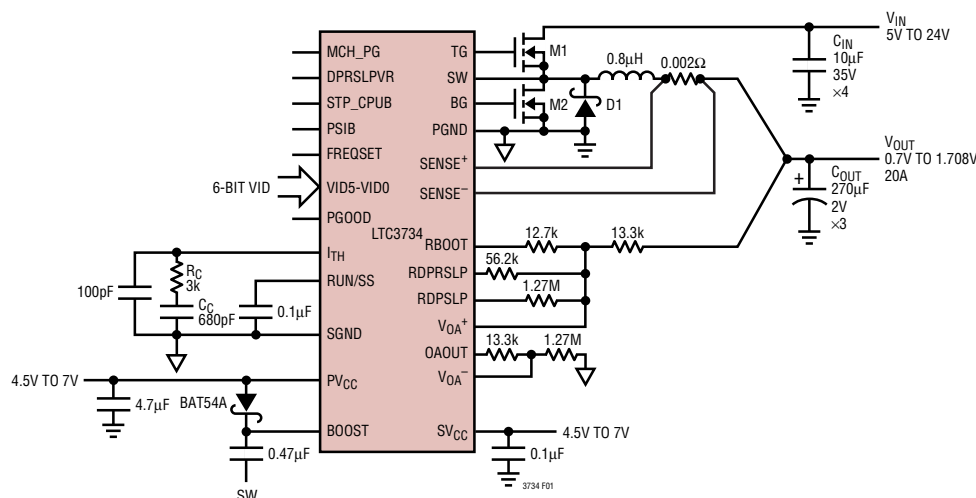

Figure 1. High Current Step-Down Converter

ABSOLUTE MAXIMUM RATINGS

(Note 1)

Input Supply Voltage (PV _{CC} , SV _{CC})	7V to -0.3V
Topside Driver Voltages (BOOST)	38V to -0.3V
Switch Voltage (SW)	32V to -5V
Boosted Driver Voltages (BOOST-SW)	7V to -0.3V
DPRSLPVR, STP_C PUB, MCH_PG, PGOOD, RDPRSLP, RDPSLP, RBOOT Voltages	5V to -0.3V
RUN/SS, FREQSET, PSIB Voltages	7V to -0.3V
VID0-VID5 Voltages	5V to -0.3V
V _{FB} Voltage	2V to -0.3V
V _{OA} ⁺ , V _{OA} ⁻ Voltage	3.6V to -0.3V
Peak Gate Drive Current <1μs (TG, BG)	5A
Operating Ambient Temperature Range (Note 2)	-40°C to 85°C
Junction Temperature (Note 3)	125°C
Storage Temperature Range	-65°C to 125°C
Reflow Peak Body Temperature	245°C

PACKAGE/ORDER INFORMATION

ORDER PART NUMBER	UH PART MARKING
LTC3734EUH	3734

Consult LTC Marketing for parts specified with wider operating temperature ranges.

ELECTRICAL CHARACTERISTICS

The ● denotes the specifications which apply over the full operating temperature range, otherwise specifications are at T_A = 25°C. V_{PVCC} = V_{SVCC} = 5V, V_{RUN/SS} = 5V unless otherwise noted.

SYMBOL	PARAMETER	CONDITIONS	MIN	TYP	MAX	UNITS	
Main Control Loop							
Reference	Regulated Feedback Voltage	I _{TH} Voltage = 0.5V; Measured at V _{FB} (Note 4)		0.600		V	
V _{SENSEMAX}	Maximum Current Sense Threshold	I _{TH} Voltage = Max; V _{CM} = 1.7V	● 59	72	85	mV	
V _{LOADREG}	Output Voltage Load Regulation	(Note 4)					
		Measured in Servo Loop, ΔI _{TH} Voltage: 1.2V to 0.7V	●	0.1	0.5	%	
		Measured in Servo Loop, ΔI _{TH} Voltage: 1.2V to 2V	●	-0.1	-0.5	%	
V _{REFLNREG}	Reference Voltage Line Regulation	V _{PVCC} = V _{SVCC} = 4.5V to 7V		0.02	0.1	%/V	
V _{PSIB}	Forced Continuous Threshold		0.57	0.6	0.63	V	
I _{PSIB}	Forced Continuous Current	V _{PSIB} = 0V		-0.5	-1	μA	
V _{OVL}	Output Overvoltage Threshold	Measured with Respect to V _{FB} = 0.6V	0.64	0.66	0.68	V	
g _m	Transconductance Amplifier g _m	I _{TH} = 1.2V, Sink/Source 25μA (Note 4)	● 4.5	6	7.5	mmho	
g _{mOL}	Transconductance Amplifier Gain	I _{TH} = 1.2V, (g _m • Z _L ; No Ext Load) (Note 4)		3		V/mV	
V _{ACTIVE}	Output Voltage in Active Mode	VID = 010110, I _{TH} = 0.5V (0°C - 85°C)		1.342	1.356	1.370	V
		VID = 010110, I _{TH} = 0.5V (Note 2)	●	1.336	1.356	1.376	V

ELECTRICAL CHARACTERISTICS

The ● denotes the specifications which apply over the full operating temperature range, otherwise specifications are at $T_A = 25^\circ\text{C}$. $V_{PVCC} = V_{SVCC} = 5\text{V}$, $V_{\text{RUN/SS}} = 5\text{V}$ unless otherwise noted.

SYMBOL	PARAMETER	CONDITIONS	MIN	TYP	MAX	UNITS	
I_Q	Input DC Supply Current Normal Mode Shutdown	(Note 5)		2	3	mA	
		$V_{\text{RUN/SS}} = 0\text{V}$		20	100	μA	
UVR	Undervoltage RUN/SS Reset	V_{CC} Lowered Until the RUN/SS Pin is Pulled Low	3.2	3.7	4.2	V	
$I_{\text{RUN/SS}}$	Soft-Start Charge Current	$V_{\text{RUN/SS}} = 1.9\text{V}$	-2.3	-1.5	-0.8	μA	
$V_{\text{RUN/SS}}$	RUN/SS Pin ON Threshold	$V_{\text{RUN/SS}}$ Rising	1.0	1.5	1.9	V	
$V_{\text{RUN/SSARM}}$	RUN/SS Pin Latchoff Arming	$V_{\text{RUN/SS}}$ Rising from 3V		3.9		V	
$V_{\text{RUN/SSLO}}$	RUN/SS Pin Latchoff Threshold	$V_{\text{RUN/SS}}$ Ramping Negative		3.2		V	
I_{SCL}	RUN/SS Discharge Current	Soft Short Condition $V_{\text{FB}} = 0.375\text{V}$, $V_{\text{RUN/SS}} = 4.5\text{V}$	-5	-1.5		μA	
I_{SDLHO}	Shutdown Latch Disable Current	$V_{\text{FB}} = 0.375\text{V}$, $V_{\text{RUN/SS}} = 4.5\text{V}$		1.5	5	μA	
I_{SENSE}	Total Sense Pins Source Current	$V_{\text{SENSE-}} = V_{\text{SENSE+}} = 0\text{V}$	-85	-60		μA	
DF _{MAX}	Maximum Duty Factor	In Dropout	95	98.5		%	
TG t_r	Top Gate Transition Time: Rise Time	(Note 6)		30	90	ns	
		$C_{\text{LOAD}} = 3300\text{pF}$					
TG t_f	Fall Time	$C_{\text{LOAD}} = 3300\text{pF}$		40	90	ns	
BG t_r	Bottom Gate Transition Time: Rise Time	(Note 6)		60	90	ns	
		$C_{\text{LOAD}} = 3300\text{pF}$					
BG t_f	Fall Time	$C_{\text{LOAD}} = 3300\text{pF}$		50	90	ns	
TG/BG t_{1D}	Top Gate Off to Bottom Gate On Delay Synchronous Switch-On Delay Time	$C_{\text{LOAD}} = 3300\text{pF}$ (Note 6)		50		ns	
BG/TG t_{2D}	Bottom Gate Off to Top Gate On Delay Top Switch-On Delay Time	$C_{\text{LOAD}} = 3300\text{pF}$ (Note 6)		60		ns	
$t_{\text{ON(MIN)}}$	Minimum On-Time	Tested with a Square Wave (Note 7)		100		ns	
VID Parameters							
R_{ATTEN}	VID Top Resistance			5.33		$\text{k}\Omega$	
ATTEN _{ERR}	Resistive Divider Error	(Note 8)	●	-0.25	0.25	%	
VID _{THLOW}	VID0 to VID5 Logic Threshold Low				0.3	V	
VID _{THHIGH}	VID0 to VID5 Logic Threshold High			0.7		V	
VID _{LEAK}	VID0 to VID5 Leakage				± 1	μA	
Oscillator							
I_{FREQSET}	FREQSET Input Current	$V_{\text{FREQSET}} = 0\text{V}$		-2	-1	μA	
f_{NOM}	Nominal Frequency	$V_{\text{FREQSET}} = 1.2\text{V}$		320	355	390	kHz
f_{LOW}	Lowest Frequency	$V_{\text{FREQSET}} = 0\text{V}$		190	210	240	kHz
f_{HIGH}	Highest Frequency	$V_{\text{FREQSET}} \geq 2.4\text{V}$		490	550	610	kHz
PGOOD Output							
V_{PGL}	PGOOD Voltage Low	$I_{\text{PGOOD}} = 2\text{mA}$		0.1	0.3	V	
I_{PGOOD}	PGOOD Leakage Current	$V_{\text{PGOOD}} = 5\text{V}$			± 1	μA	
V_{PG}	PGOOD Trip Level	V_{FB} with Respect to Set Output Voltage		-7	-10	-13	%
		V_{FB} Ramping Negative		7	10	13	%
t_{MASK}	PGOOD Mask Timer			100	110	120	μs
t_{DELAY}	MCH_PG Delay Time			15		cycles	

ELECTRICAL CHARACTERISTICS The ● denotes the specifications which apply over the full operating temperature range, otherwise specifications are at $T_A = 25^\circ\text{C}$. $V_{PVCC} = V_{SVCC} = 5\text{V}$, $V_{\text{RUN/SS}} = 5\text{V}$ unless otherwise noted.

SYMBOL	PARAMETER	CONDITIONS	MIN	TYP	MAX	UNITS
Operational Amp						
I_B	Input Bias Current			15	200	nA
V_{OS}	Input Offset Voltage Magnitude	$V_{OA^+} = V_{OA^-} = 1.2\text{V}$, $I_{OUT} = 1\text{mA}$		0.8	5	mV
CM	Common Mode Input Voltage Range		0		$PV_{CC} - 1.4$	V
CMRR	Common Mode Rejection Ratio	$I_{OUT} = 1\text{mA}$	46	70		dB
I_{CL}	Output Source Current		10	35		mA
AV_{OL}	Open-Loop DC Gain	$I_{OUT} = 1\text{mA}$		30		V/mV
GBP	Gain-Bandwidth Product	$I_{OUT} = 1\text{mA}$		2		MHz
SR	Slew Rate	$R_L = 2\text{k}$		5		V/ μs
$V_{O(\text{MAX})}$	Maximum High Output Voltage	$I_{OUT} = 1\text{mA}$		$PV_{CC} - 1.2$	$PV_{CC} - 0.9$	V

Note 1: Absolute Maximum Ratings are those values beyond which the life of a device may be impaired.

Note 2: The LTC3734E is guaranteed to meet performance specifications from 0°C to 70°C . Specifications over the -40°C to 85°C operating temperature range are assured by design, characterization and correlation with statistical process controls.

Note 3: T_J is calculated from the ambient temperature T_A and power dissipation P_D according to the following formula:

$$LTC3734EUH: T_J = T_A + (P_D \cdot 34^\circ\text{C/W})$$

Note 4: The LTC3734 is tested in a feedback loop that servos $V_{I\text{TH}}$ to a specified voltage and measures the resultant V_{FB} .

Note 5: Dynamic supply current is higher due to the gate charge being delivered at the switching frequency. See Applications Information.

Note 6: Rise and fall times are measured using 10% and 90% levels. Delay times are measured using 50% levels.

Note 7: The minimum on-time condition corresponds to the on inductor peak-to-peak ripple current $\geq 40\%$ I_{MAX} (see Minimum On-Time Considerations in the Applications Information section).

Note 8: The $\text{ATTEN}_{\text{ERR}}$ specification is in addition to the output voltage accuracy specified at VID code = 010110.

TYPICAL PERFORMANCE CHARACTERISTICS

Active Mode Efficiency
(VID = 1.186V, PSI = 0) (Figure 9)

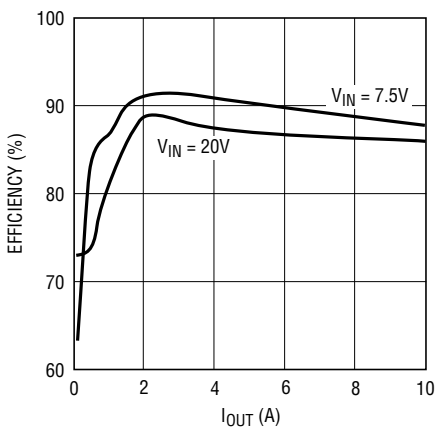

3735 G01

Deeper Sleep Mode Efficiency
(Figure 9)

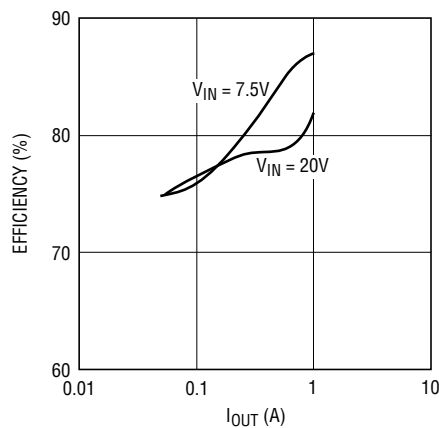

3734 G02

Efficiency vs Input Voltage
(Figure 9)

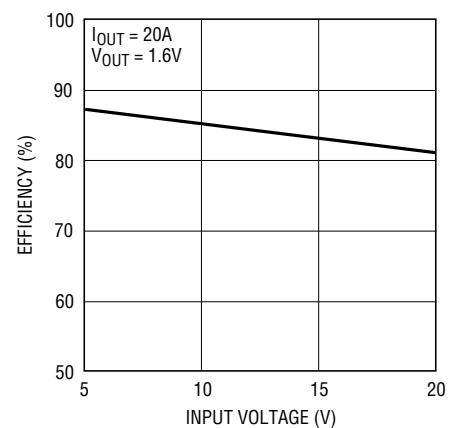

3734 G03

TYPICAL PERFORMANCE CHARACTERISTICS

Supply Current vs SV_{CC} Voltage and Mode

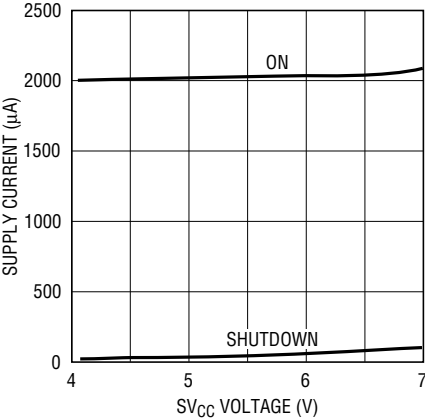

3734 G04

Maximum Current Sense Threshold vs Duty Factor

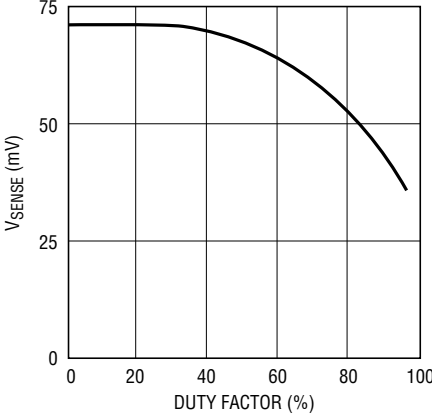

3734 G05

Maximum Current Sense Threshold vs Percent of Nominal Output Voltage (Foldback)

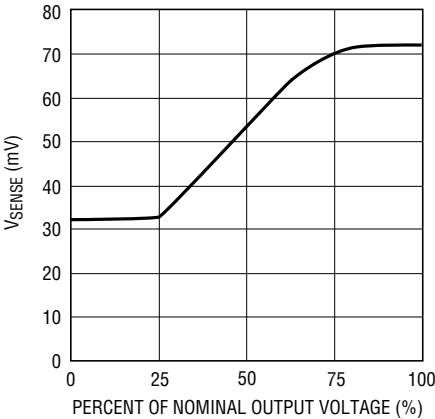

3734 G06

Maximum Current Sense Threshold vs $V_{RUN/SS}$ (Soft-Start)

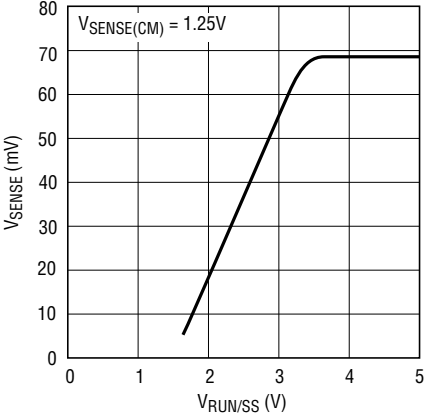

3734 G07

Maximum Current Sense Threshold vs Sense Common Mode Voltage

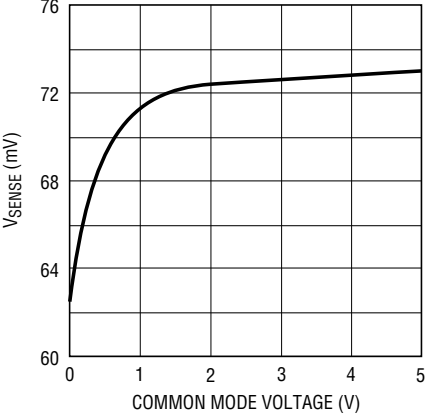

3734 G08

Current Sense Threshold vs I_{TH} Voltage

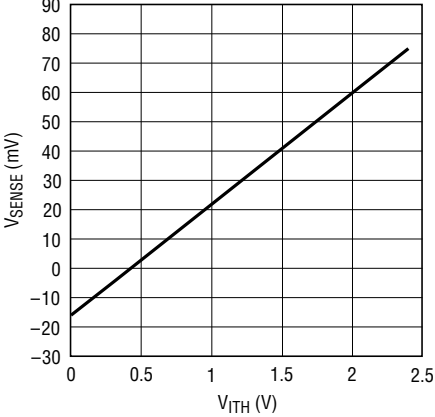

3734 G09

Load Regulation (without AVP)

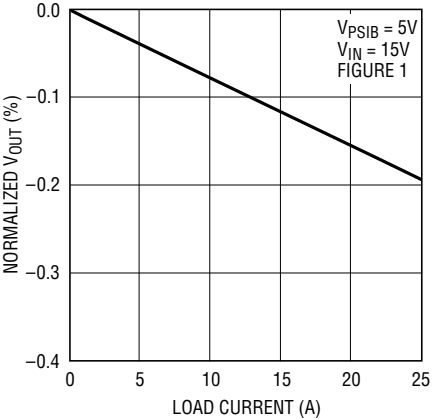

3734 G10

SENSE Pins Total Source Current

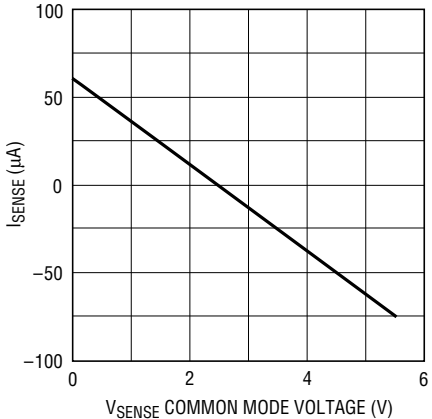

3734 G12

TYPICAL PERFORMANCE CHARACTERISTICS

Maximum Current Sense Threshold vs Temperature

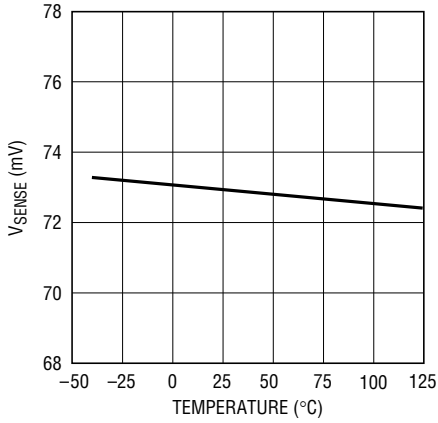

3734 G13

RUN/SS Current vs Temperature

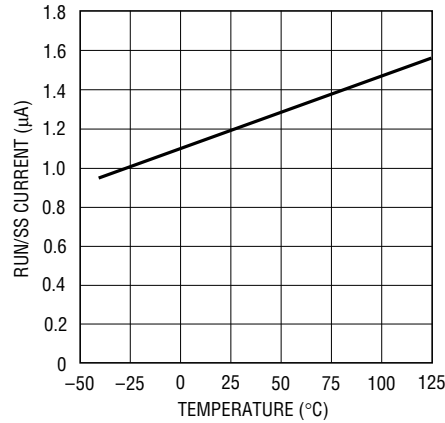

3734 G14

Load Step (Figure 9)

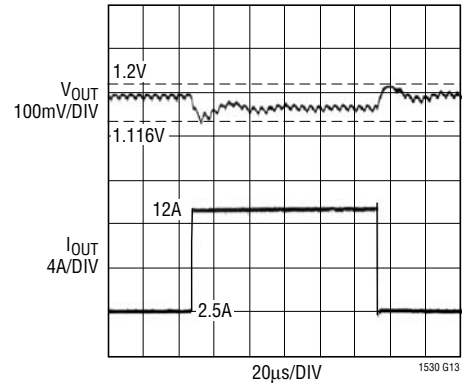

1530 G13

Current Sense Pin Input Current vs Temperature

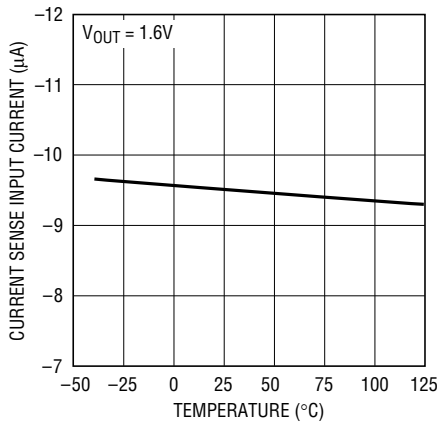

3734 G16

Oscillator Frequency vs Temperature

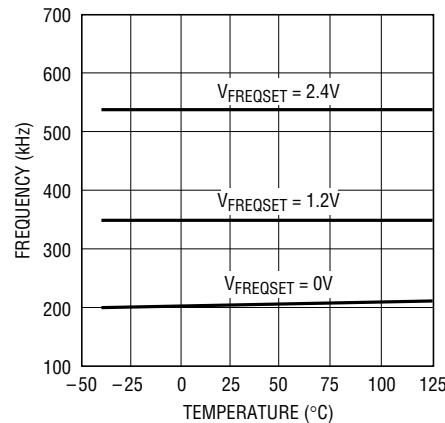

3734 G17

V_{RUN/SS} Shutdown Latch Thresholds vs Temperature

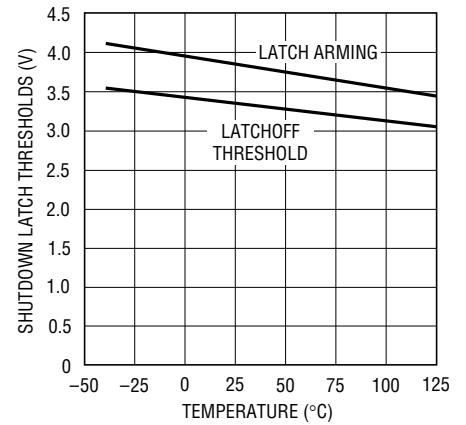

3734 G19

PIN FUNCTIONS

V_{OA}^+ , V_{OA}^- (Pins 1, 2): Inputs to the Internal Operational Amplifier.

OAOUT (Pin 3): Output of the Internal Operational Amplifier.

STP_CPUB (Pin 4): Deep Sleep State Input. When the signal to this pin is low, the voltage regulator enters deep sleep state and its output voltage is a certain percentage lower than the VID commands. This offset percentage is set by the resistor connected to the RDPSLP pin. When the signal to this pin is high, the voltage regulator exits deep sleep state.

SGND (Pin 5): Signal Ground. All small-signal components and compensation components should connect to this ground which, in turn, connects to PGND at one point.

SENSE⁺ (Pin 6): The (+) Input to the Differential Current Comparator. The I_{TH} pin voltage and built-in offsets between SENSE⁻ and SENSE⁺ pins in conjunction with R_{SENSE} set the current trip threshold.

SENSE⁻ (Pin 7): The (-) Input to the Differential Current Comparator.

RDPSLP (Pin 8): Deeper Sleep State Resistor Pin. Connect a resistor from this pin to V_{OA}^+ . This resistor in conjunction with the RDPSLP resistor sets the output voltage of the regulator in deeper sleep state.

RDPSLP (Pin 9): Deep Sleep Resistor Pin. Connect a resistor from this pin to V_{OA}^+ . This resistor sets the percentage offset of output voltage in deep sleep state.

RUN/SS (Pin 10): Combination of Soft-Start, Run Control Input and Short-Circuit Detection Timer. A capacitor to ground at this pin sets the ramp time to full current output. Forcing this pin below 1V causes the IC to shut down all internal circuitry. All functions are disabled in shutdown.

I_{TH} (Pin 11): Error Amplifier Output and Switching Regulator Compensation Point. The current comparator's threshold increases with this control voltage. The normal voltage range of this pin is from 0V to 2.4V

RBOOT (Pin 12): Boot-Up Resistor Pin. Connect a resistor from this pin to V_{OA}^+ . This resistor sets the output voltage during the initial boot-up.

VID0–VID5 (Pins 13, 14, 15, 17, 18, 19): VID Control Logic Input Pins.

NC (Pin 16): Not Connected.

PGND (Pin 20): Driver Power Ground. Connect to sources of bottom N-channel MOSFETs and the (-) terminals of C_{IN} .

BG (Pin 21): High Current Gate Drive for Bottom N-Channel MOSFETs. Voltage swing at this pin is from ground to PV_{CC} .

PV_{CC} (Pin 22): Power Supply Pin. The on chip gate drivers are powered from this voltage source. Decouple to PGND with a minimum of 4.7 μ F X5R/X7R ceramic capacitor placed directly adjacent to the IC.

PIN FUNCTIONS

SW (Pin 23): Switch Node Connection to Inductor. Voltage swing at this pin is from a Schottky diode (external) voltage drop below ground to V_{IN} .

TG (Pin 24): High Current Gate Drive for Top N-Channel MOSFETs. This is the output of a floating driver with a voltage swing equal to PV_{CC} superimposed on the switch node voltage SW.

BOOST (Pin 25): Bootstrapped Supply to the Topside Floating Driver. External capacitor is connected between the BOOST and SW pins, and a Schottky diode is connected between the BOOST and PV_{CC} pins.

PGOOD (Pin 26): Power Good Indicator Output. This pin is open drain when output is within $\pm 10\%$ of its set point. When output is not within the $\pm 10\%$ window, this pin is pulled to ground. An internal timer watches over VID, state transitions, overvoltage or undervoltage conditions, then masks PGOOD from going low for $110\mu s$.

MCH_PG (Pin 27): MCH Power Good Input. Output voltage remains V_{BOOT} for 15 clock cycles after the assertion of MCH_PG. This delay is only sensitive to the rising edge of the MCH_PG logic signal.

V_{FB} (Pin 28): Input to the error amplifier that compares the feedback voltage to the internal 0.6V reference voltage.

SV_{CC} (Pin 29): Signal Power Pin. The internal control circuits are powered from this voltage source.

DPRSLPVR (Pin 30): Deeper Sleep State Input. When the signal to this pin is high, the voltage regulator enters deeper sleep state and its output is determined by the parallel resistor value of RDPRSLP and RDPSLP. When the signal is low, the voltage regulator exits deeper sleep state.

FREQSET (Pin 31): Frequency Set Pin. Apply a DC voltage between 0V and 5V to set the operating frequency of the internal oscillator. This frequency is the switching frequency of the controller.

PSIB (Pin 32): Power Status Indicator Input. When the signal to this pin is high, the controller operates in fully synchronous switching mode for fastest transient and lowest ripple. When the signal is low, controller enters power saving mode, providing high efficiency at light load.

Exposed Pad (Pin 33): Signal Ground. Must be soldered to the PCB.

FUNCTIONAL DIAGRAM

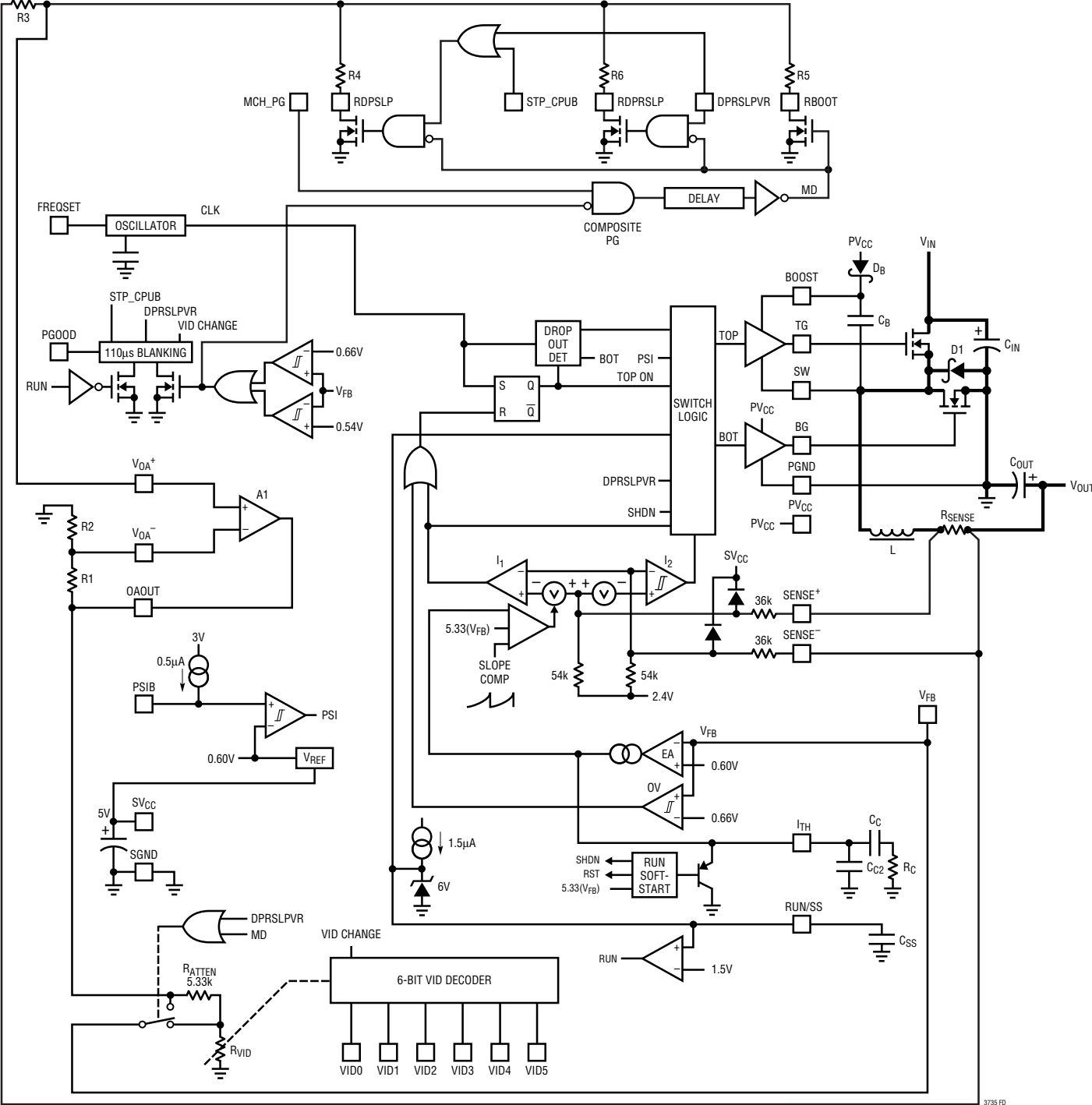

3735 FD

OPERATION (Refer to Functional Diagram)

Main Control Loop

The LTC3734 uses a constant frequency, current mode step-down architecture. During normal operation, the top MOSFET is turned on when the clock sets the RS latch, and turned off when the main current comparator, I_1 , resets the RS latch. The peak inductor current at which I_1 resets the RS latch is controlled by the voltage on the I_{TH} pin, which is the output of error amplifier EA. The V_{FB} pin receives the voltage feedback signal, which is compared to the internal reference voltage by the EA. When the load current increases, it causes a slight decrease in EA inverting input node relative to the 0.6V reference, which in turn causes the I_{TH} voltage to increase until the average inductor current matches the new load current. After the top MOSFET has turned off, the bottom MOSFET is turned on until either the inductor current starts to reverse, as indicated by current comparator I_2 , or the beginning of the next cycle.

The top MOSFET driver is biased from a floating bootstrap capacitor C_B , which normally is recharged during each off cycle through an external diode when the top MOSFET turns off. As V_{IN} decreases to a voltage close to V_{OUT} , the loop may enter dropout and attempt to turn on the top MOSFET continuously. The dropout detector detects this and forces the top MOSFET off for about 500ns every sixth cycle to allow C_B to recharge.

The main control loop is shut down by pulling the RUN/SS pin low. Releasing RUN/SS allows an internal 1.5 μ A current source to charge soft-start capacitor C_{SS} . When C_{SS} reaches 1.5V, the main control loop is enabled with the internal I_{TH} voltage clamped at approximately 30% of its maximum value. As C_{SS} continues to charge, the internal I_{TH} voltage is gradually released allowing normal, full-current operation.

Frequency Programming

The switching frequency of the LTC3734 is determined by the DC voltage at the FREQSET pin. A DC voltage ranging from 0V to 2.4V moves the internal oscillator frequency from 210kHz to 550kHz.

Low Current Operation (PSIB)

The PSIB pin selects between two modes of operation. When PSIB is above 0.6V, the controller operates in full synchronous switching mode. Bottom driver (BG) is kept on once it is turned on until the oscillator sets the RS latch. The inductor current can therefore go from output back to input power supply and could potentially boost the input supply to dangerous voltage levels—BEWARE! This mode of operation is also of lower efficiency and much current can circulate between input and output. However, this mode provides constant switching frequency.

When PSIB is below 0.6V, the bottom driver (BG) is turned off if the inductor current starts to reverse. This mode of operation prevents current going from output back to input and eliminates the conduction power loss related to circulating current. The circuit may skip switching cycles at very light load conditions.

Output Voltage at Start-Up and at Deeper Sleep State

Under normal conditions, the output voltage of the regulator is commanded by six VID bits, except at start-up and at deeper sleep state. At start-up, the RUN/SS capacitor starts to charge up and its voltage limits the inrush current from the input power source. This linearly rising current limit provides a controlled output voltage rise. During start-up, the VID command is ignored and the output set point is determined by the value of the resistor connected to the RBOOT pin. The VID bits continue to be ignored for 15 switching cycles after the completion of the following two conditions: 1) output voltage has risen up and has regulated 2) MCH_PG signal has asserted. After 15 switching cycles, output voltage is fully commanded by VID bits.

In deeper sleep state, the VID command is also ignored and the output set point is determined by the parallel value of the resistors at the RDPRSLP pin and RDPSLP pin.

OPERATION (Refer to Functional Diagram)

Operational Amplifier and Deep Sleep Offset

The internal operational amplifier provides a programmable output offset at deep sleep state (when the STP_CPUB signal is low). The offset percentage is programmed by the resistor from RDPSLP to V_{OA}^+ and the resistor from output to V_{OA}^+ . The amplifier has an output slew rate of $5V/\mu s$ and is capable of driving capacitive loads with an output RMS current typically up to 40mA. The open-loop gain of the amplifier is $>120dB$ and the unity-gain bandwidth is 2MHz.

Output Overvoltage Protection

An overvoltage comparator, OV, guards against transient overshoots ($>10\%$) as well as other more serious conditions that may overvoltage the output. In this case, the top MOSFET is turned off and the bottom MOSFET is turned on until the overvoltage condition is cleared.

Power Good

The PGOOD pin is connected to the drain of an internal N-channel MOSFET. The MOSFET turns on when the output voltage is not within $\pm 10\%$ of its nominal set point. When the output voltage is within $\pm 10\%$ of its nominal set point, the MOSFET turns off and PGOOD is high impedance. PGOOD monitors the V_{BOOT} voltage when MCH_PG is not asserted. During VID, deep sleep or deeper sleep

transitions, PGOOD is masked from going low for $110\mu s$, preventing the system from resetting during CPU mode changes. When VID bits, STP_CPUB or DPRSLPVR signals change again after a previous transition, but before the timer expires, the internal timer resets.

Short-Circuit Detection

The RUN/SS capacitor is used initially to limit the inrush current from the input power source. Once the controller has been given time, as determined by the capacitor on the RUN/SS pin, to charge up the output capacitors and provide full-load current, the RUN/SS capacitor is then used as a short-circuit timeout circuit. If the output voltage falls to less than 70% of its nominal output voltage the RUN/SS capacitor begins discharging assuming that the output is in a severe overcurrent and/or short-circuit condition. If the condition lasts for a long enough period as determined by the size of the RUN/SS capacitor, the controller will be shut down until the RUN/SS pin voltage is recycled. This built-in latching can be overridden by providing a current $>5\mu A$ to the RUN/SS pin. This current shortens the soft-start period but also prevents net discharge of the RUN/SS capacitor during a severe overcurrent and/or short-circuit condition. Fold-back current limiting is activated when the output voltage falls below 70% of its nominal level whether or not the short-circuit latching circuit is enabled.

APPLICATIONS INFORMATION

The basic LTC3734 application circuit is shown in Figure 1 on the first page of this data sheet. External component selection begins with the selection of the inductors based on ripple current requirements and continues with the current sensing resistors using the calculated peak inductor current and/or maximum current limit. Next, the power MOSFET, D1 is selected. The operating frequency and the inductor are chosen based mainly on the amount of ripple current. Finally, C_{IN} is selected for its ability to handle the input ripple current and C_{OUT} is chosen with low enough ESR to meet the output ripple voltage and load step specifications. The circuit shown in Figure 1 can be configured for operation up to an input voltage of 28V (limited by the external MOSFETs).

R_{SENSE} Selection For Output Current

R_{SENSE} is chosen based on the required peak output current. The LTC3734 current comparator has a maximum threshold of $72\text{mV}/R_{SENSE}$ and an input common mode range of SGND to SV_{CC} . The current comparator threshold sets the peak inductor current, yielding a maximum average output current I_{MAX} equal to the peak value less half the peak-to-peak ripple current, ΔI_L .

Allowing a margin for variations in the LTC3734 and external component values yields:

$$R_{SENSE} = (40\text{mV}/I_{MAX})$$

Operating Frequency

The LTC3734 uses a constant frequency architecture with the frequency determined by an internal capacitor. This capacitor is charged by a fixed current plus an additional current which is proportional to the DC voltage applied to the FREQSET pin. The FREQSET voltage is internally set to 1.2V. It is recommended that this pin is actively biased with a resistor divider to prevent noise getting into the system.

A graph for the voltage applied to the FREQSET pin vs frequency is given in Figure 2. As the operating frequency is increased the gate drive and switching losses will be higher, reducing efficiency (see Efficiency Considerations). The maximum switching frequency is approximately 550kHz.

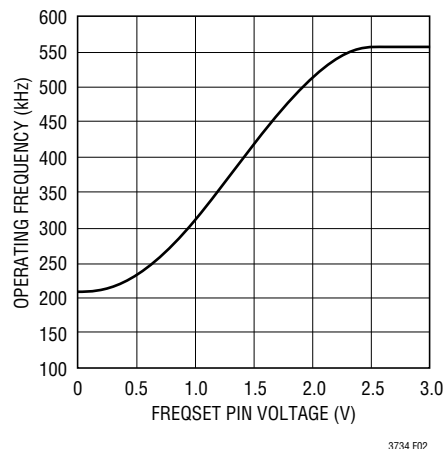

Figure 2. Operating Frequency vs $V_{FREQSET}$

Inductor Value Calculation and Output Ripple Current

The operating frequency and inductor selection are inter-related in that higher operating frequencies allow the use of smaller inductor and capacitor values. So why would anyone ever choose to operate at lower frequencies with larger components? The answer is efficiency. A higher frequency generally results in lower efficiency because MOSFET gate charge and transition losses increase directly with frequency. In addition to this basic tradeoff, the effect of inductor value on ripple current and low current operation must also be considered.

The inductor value has a direct effect on ripple current. The inductor ripple current ΔI_L , decreases with higher inductance or frequency and increases with higher V_{IN} :

$$\Delta I_L = \frac{V_{OUT}}{fL} \left(1 - \frac{V_{OUT}}{V_{IN}} \right)$$

where f is the individual output stage operating frequency.

Accepting larger values of ΔI_L allows the use of low inductances, but can result in higher output voltage ripple. A reasonable starting point for setting ripple current is $\Delta I_L = 0.4(I_{OUT})$, where I_{OUT} is the maximum load current. Remember, the maximum ΔI_L occurs at the maximum input voltage. The inductor ripple current is determined by the frequency, inductance, input and output voltages.

APPLICATIONS INFORMATION

Inductor Core Selection

Once the value for L1 is known, the type of inductor must be selected. High efficiency converters generally cannot afford the core loss found in low cost powdered iron cores, forcing the use of more expensive ferrite, molypermalloy, or Kool M μ ® cores. Actual core loss is independent of core size for a fixed inductor value, but it is very dependent on inductor type selected. As inductance increases, core losses go down. Unfortunately, increased inductance requires more turns of wire and therefore copper losses will increase.

Ferrite designs have very low core loss and are preferred at high switching frequencies, so design goals can concentrate on copper loss and preventing saturation. Ferrite core material saturates “hard,” which means that inductance collapses abruptly when the peak design current is exceeded. This results in an abrupt increase in inductor ripple current and consequent output voltage ripple. *Do not allow the core to saturate!*

A variety of inductors designed for high current, low voltage applications are available from manufacturers such as Sumida, Coilcraft, Coiltronics, Toko and Panasonic.

Power MOSFET, D1 Selection

External power MOSFETs must be selected for output stage with the LTC3734: one N-channel MOSFET for the top (main) switch, and one N-channel MOSFET for the bottom (synchronous) switch.

The peak-to-peak drive levels are set by the PV_{CC} voltage. This voltage typically ranges from 4.5V to 7V. Consequently, logic-level threshold MOSFETs must be used in most applications. Pay close attention to the BV_{DSS} specification for the MOSFETs as well; most of the logic-level MOSFETs are limited to 30V or less.

Selection criteria for the power MOSFETs include the “ON” resistance R_{DS(ON)}, gate charge Q_G, reverse transfer capacitance C_{RSS}, breakdown voltage BV_{DSS} and maximum continuous drain current I_{D(MAX)}.

When the LTC3734 operates at continuous mode in a step-down configuration, the duty cycles for the top and bottom

MOSFETs are approximately:

$$\text{Top MOSFET Duty Cycle} = \frac{V_{\text{OUT}}}{V_{\text{IN}}} \quad (1)$$

$$\text{Bottom MOSFET Duty Cycle} = \frac{V_{\text{IN}} - V_{\text{OUT}}}{V_{\text{IN}}} \quad (2)$$

The conduction losses of the top and bottom MOSFETs are therefore:

$$P_{\text{CONTOP}} = \frac{V_{\text{OUT}}}{V_{\text{IN}}} \cdot (I_{\text{OUT}})^2 \cdot (1 + \delta \cdot \Delta T) \cdot R_{\text{DS(ON)}} \quad (3)$$

$$P_{\text{CONBOT}} = \frac{V_{\text{IN}} - V_{\text{OUT}}}{V_{\text{IN}}} \cdot (I_{\text{OUT}})^2 \cdot (1 + \delta \cdot \Delta T) \cdot R_{\text{DS(ON)}} \quad (4)$$

where I_{OUT} is the maximum output current at full load, ΔT is the difference between MOSFET operating temperature and room temperature, and δ is the temperature dependency of R_{DS(ON)}. δ is roughly 0.004/°C ~ 0.006/°C for low voltage MOSFETs.

The power losses of driving the top and bottom MOSFETs are simply:

$$P_{\text{DRTOP}} = Q_{\text{G}} \cdot PV_{\text{CC}} \cdot f \quad (5)$$

$$P_{\text{DRBOT}} = Q_{\text{G}} \cdot PV_{\text{CC}} \cdot f \quad (6)$$

Use Q_G data at V_{GS} = PV_{CC} in MOSFET data sheets. f is the switching frequency as described previously. Please notice that the above gate driving losses are usually not dissipated by the MOSFETs. Instead they are mainly dissipated on the internal drivers of the LTC3734, if there are no resistors connected between the drive pins (TG, BG) and the gates of the MOSFETs.

The calculation of MOSFET switching loss is complicated by several factors including the wide distribution of power MOSFET threshold voltage, the nonlinearity of current rising/falling characteristic and the Miller Effect. Given the data in a typical power MOSFET data sheet, the switching losses of the top and bottom MOSFETs can only be estimated as follows:

Kool M μ is a registered trademark of Magnetics, Inc.

APPLICATIONS INFORMATION

$$P_{\text{SWTOP}} = V_{\text{IN}}^2 \cdot \frac{I_{\text{OUT}}}{2} \cdot f \cdot C_{\text{RSS}} \cdot R_{\text{DR}} \cdot \quad (7)$$

$$\left(\frac{1}{V_{\text{DR}} - V_{\text{TH(MIN)}}} + \frac{1}{V_{\text{TH(MIN)}}} \right)$$

$$P_{\text{SWBOT}} \approx 0 \quad (8)$$

where R_{DR} is the effective driver resistance (of approximately 2Ω), V_{DR} is the driving voltage ($= PV_{\text{CC}}$) and $V_{\text{TH(MIN)}}$ is the minimum gate threshold voltage of the MOSFET. Please notice that the switching loss of the bottom MOSFET is effectively negligible because the current conduction of the antiparalleling diode. This effect is often referred as zero-voltage-transition (ZVT). Similarly when the LTC3734 converter works under fully synchronous mode at light load, the reverse inductor current can also go through the body diode of the top MOSFET and make the turn-on loss to be negligible. However, equations 7 and 8 have to be used in calculating the worst-case power loss, which happens at highest load level.

The selection criteria of power MOSFETs start with the stress check:

$$V_{\text{IN}} < BV_{\text{DSS}}$$

$$I_{\text{MAX}} < I_{\text{D(MAX)}}$$

and

$$P_{\text{CONTOP}} + P_{\text{SWTOP}} < \text{top MOSFET maximum power dissipation specification}$$

$$P_{\text{CONBOT}} + P_{\text{SWBOT}} < \text{bottom MOSFET maximum power dissipation specification}$$

The maximum power dissipation allowed for each MOSFET depends heavily on MOSFET manufacturing and packaging, PCB layout and power supply cooling method. Maximum power dissipation data are usually specified in MOSFET data sheets under different PCB mounting conditions.

The next step of selecting power MOSFETs is to minimize the overall power loss:

$$\begin{aligned} P_{\text{OVL}} &= P_{\text{TOP}} + P_{\text{BOT}} \\ &= (P_{\text{CONTOP}} + P_{\text{DRTOP}} + P_{\text{SWTOP}}) + (P_{\text{CONBOT}} + P_{\text{DRBOT}} + P_{\text{SWBOT}}) \end{aligned}$$

For typical mobile CPU applications where the ratio between input and output voltages is higher than 2:1, the bottom MOSFET conducts load current most of the time while the main losses of the top MOSFET are for switching and driving. Therefore a low $R_{\text{DS(ON)}}$ part (or multiple parts in parallel) would minimize the conduction loss of the bottom MOSFET while a higher $R_{\text{DS(ON)}}$ but lower Q_{G} and C_{RSS} part would be desirable for the top MOSFET.

The Schottky diode, D1 in Figure 1, conducts during the dead-time between the conduction of the top and bottom MOSFETs. This helps reduce the current flowing through the body diode of the bottom MOSFET. A body diode usually has a forward conduction voltage higher than that of a Schottky and is thus detrimental to efficiency. The charge storage and reverse recovery of a body diode also cause high frequency rings at the switching nodes (the conjunction nodes between the top and bottom MOSFETs), which are again not desired for efficiency or EMI. Some power MOSFET manufacturers integrate a Schottky diode with a power MOSFET, eliminating the need to parallel an external Schottky. These integrated Schottky-MOSFETs, however, have smaller MOSFET die sizes than conventional parts and are thus not suitable for high current applications.

C_{IN} and C_{OUT} Selection

In continuous mode, the source current of each top N-channel MOSFET is a square wave of duty cycle $V_{\text{OUT}}/V_{\text{IN}}$. A low ESR input capacitor sized for the maximum RMS current must be used. The RMS input ripple current is estimated to be:

$$I_{\text{RMS}} \cong I_{\text{OUT(MAX)}} \frac{V_{\text{OUT}}}{V_{\text{IN}}} \sqrt{\frac{V_{\text{IN}}}{V_{\text{OUT}}} - 1}$$

This formula has a maximum at $V_{\text{IN}} = 2V_{\text{OUT}}$, where $I_{\text{RMS}} = I_{\text{OUT(MAX)}}$ /2

This simple worst-case condition is commonly used for design, considering input/output variations and long term reliability. Note that capacitor manufacturer's ripple current ratings are often based on only 2000 hours of life. This makes it advisable to further derate the capacitor, or to choose a capacitor rated at a higher temperature than

APPLICATIONS INFORMATION

required. Several capacitors may also be paralleled to meet size or height requirements in the design. Always consult the capacitor manufacturer if there is any question.

The selection of C_{OUT} is driven by the required effective series resistance (ESR). Typically once the ESR requirement has been met, the RMS current rating generally far exceeds the $I_{RIPPLE(P-P)}$ requirements. The steady state output ripple (ΔV_{OUT}) is determined by:

$$\Delta V_{OUT} \approx \Delta I_L \left(ESR + \frac{1}{8fC_{OUT}} \right)$$

Where f = operating frequency of each stage, C_{OUT} = output capacitance and ΔI_L is inductor peak-to-peak ripple current.

The LTC3734 employs OPTI-LOOP technique to compensate the switching regulator loop with external components (through I_{TH} pin). OPTI-LOOP compensation speeds up regulator's transient response, minimizes output capacitance and effectively removes constraints on output capacitor ESR. It opens a much wider selection of output capacitor types and a variety of capacitor manufacturers are available for high current, low voltage switching regulators.

Manufacturers such as Nichicon, United Chemicon and Sanyo should be considered for high performance through-hole capacitors. The OS-CON semiconductor dielectric capacitor available from Sanyo has the lowest (ESR)(size) product of any aluminum electrolytic at a somewhat higher price. An additional ceramic capacitor in parallel with OS-CON type capacitors is recommended to reduce the inductance effects.

In surface mount applications, multiple capacitors may have to be paralleled to meet the ESR or RMS current handling requirements of the application. Aluminum electrolytic and dry tantalum capacitors are both available in surface mount configurations. New special polymer (SP) surface mount capacitors from Panasonic offer very low ESR also but have much lower capacitive density per unit

volume. In the case of tantalum, it is critical that the capacitors are surge tested for use in switching power supplies. Several excellent choices are the AVX TPS, AVX TPSV or the KEMET T510 series of surface mount tantalums, available in case heights ranging from 2mm to 4mm. Other capacitor types include Sanyo OS-CON, POSCAPs, Kemet AO-CAPs, Nichicon PL series and Sprague 595D series. Consult the manufacturer for other specific recommendations. A combination of capacitors will often result in maximizing performance and minimizing overall cost and size.

PV_{CC} and SV_{CC} Decoupling

The PV_{CC} pin supplies power to the bottom gate driver and therefore must be bypassed to power ground with a minimum of 4.7 μ F ceramic or tantalum capacitor. Since the gate driving currents are of high amplitude and high slew rate, this bypassing capacitor should be placed very close to the PV_{CC} and PGND pins to minimize the parasitic inductance. Do NOT apply greater than 7V to the PV_{CC} pin.

The SV_{CC} pin supplies current to the internal control circuitry of the LTC3734. This supply current is much lower than that of the current for the external MOSFET gate drive. Ceramic capacitors are very good for high frequency filtering and a 0.1 μ F ~ 1 μ F ceramic capacitor should be placed adjacent to the SV_{CC} and SGND pins.

Topside MOSFET Driver Supply (C_B, D_B) (Refer to Functional Diagram)

External bootstrap capacitor C_B connected to the BOOST pin supplies the gate drive voltages for the topside MOSFETs. Capacitor C_B in the Functional Diagram is charged through diode D_B from PV_{CC} when the SW pin is low. When the topside MOSFET turns on, the driver places the C_B voltage across the gate-source of the desired MOSFET. This enhances the MOSFET and turns on the topside switch. The switch node voltage, SW, rises to V_{IN} and the BOOST pin rises to $V_{IN} + PV_{CC}$. The value of the boost capacitor C_B needs to be 30 to 100 times that of the total input capacitance of the topside MOSFET(s). The reverse breakdown of D_B must be greater than $PV_{CC(MAX)}$.

APPLICATIONS INFORMATION

VID Output Voltage Programming

After $27\mu\text{s} \sim 71\mu\text{s}$ t_{BOOT} delay, the output voltage of the regulator is digitally programmed as defined in Table 1 using the VID0 to VID5 logic input pins. The VID logic inputs program a precision, 0.25% internal feedback resistive divider. The LTC3734 has an output voltage range of 0.700V to 1.708V in 16mV steps.

Referring to the Functional Diagram, there is a resistor, R_{VID} , from V_{FB} to ground. The value of R_{VID} is controlled by the six VID input pins. Another internal resistor, 5.33k (R_{ATTEN}), completes the resistive divider. The output voltage is thus set by the ratio of $(R_{\text{VID}} + 5.33\text{k})$ to R_{VID} .

Each VID digital pin is a high impedance input. Therefore they must be actively pulled high or pulled low. The logic low threshold of the VID pins is 0.3V; the logic high threshold is 0.7V.

Soft-Start/Run Function

The RUN/SS pin provides three functions: 1) run/shutdown, 2) soft-start and 3) an optional short-circuit latching timer. Soft-start reduces the input power source's surge currents by gradually increasing the controller's current limit. The latching timer prevents very short, extreme load transients from tripping the overcurrent latch. A small pull-up current ($>5\mu\text{A}$) supplied to the RUN/SS pin will prevent the overcurrent latch from operating. The following paragraph describes how the functions operate.

An internal $1.5\mu\text{A}$ current source charges up the soft-start capacitor, C_{SS} . When the voltage on RUN/SS reaches 1.5V, the controller is permitted to start operating. As the voltage on RUN/SS increases from 1.5V to 3.0V, the internal current limit is increased from $25\text{mV}/R_{\text{SENSE}}$ to $72\text{mV}/R_{\text{SENSE}}$. The output current thus ramps up slowly, eliminating the starting surge current required from the input power supply. If RUN/SS has been pulled all the way to ground there is a delay before starting of approximately:

$$t_{\text{DELAY}} = \frac{1.5\text{V}}{1.5\mu\text{A}} C_{\text{SS}} = (1\text{s}/\mu\text{F}) C_{\text{SS}}$$

The time for the output current to ramp up is then:

$$t_{\text{RAMP}} = \frac{3\text{V} - 1.5\text{V}}{1.5\mu\text{A}} C_{\text{SS}} = (1\text{s}/\mu\text{F}) C_{\text{SS}}$$

By pulling the RUN/SS pin below 1V the LTC3734 is put into low current shutdown ($I_{\text{Q}} < 100\mu\text{A}$). The RUN/SS pin can be driven directly from logic as shown in Figure 3. Diode D1 in Figure 3 reduces the start delay but allows C_{SS} to ramp up slowly providing the soft-start function. The RUN/SS pin has an internal 6V zener clamp (see Functional Diagram).

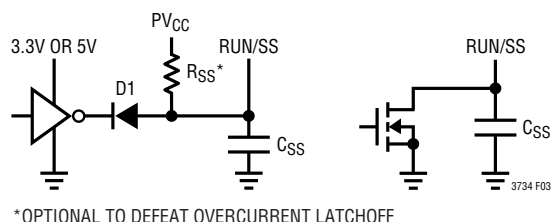

Figure 3. RUN/SS Pin Interfacing

Start-Up Sequence (Refer to the Functional Diagram)

After soft-start, the output voltage of the regulator settles at a voltage level equal to V_{BOOT} .

$$V_{\text{BOOT}} = 0.6\text{V} \cdot \frac{R2 \cdot (R3 + R5)}{R5 \cdot (R1 + R2)}$$

By using different $R5$ resistors, V_{BOOT} can be programmed.

After the output voltage enters the $\pm 10\%$ regulation window centered at V_{BOOT} , the internal power good comparator issues a logic high signal. Refer to the timing diagram in Figure 4. This signal then enters a logic AND gate, with MCH_PG being the other input, and the output of the gate is PG shown in Figure 4. This composite PG signal is then delayed by t_{BOOT} amount of time and then becomes MD. As soon as MD is asserted, the output voltage changes from V_{BOOT} to V_{VID} , a voltage level totally controlled by the six VID bits. In the LTC3734, the time t_{BOOT} is set to be 15 switching cycles:

$$t_{\text{BOOT}} = 15 \frac{1}{f_{\text{S}}}$$

If f_{S} is set at 210kHz, $t_{\text{BOOT}} = 71\mu\text{s}$

If f_{S} is set at 550kHz, $t_{\text{BOOT}} = 27\mu\text{s}$

APPLICATIONS INFORMATION

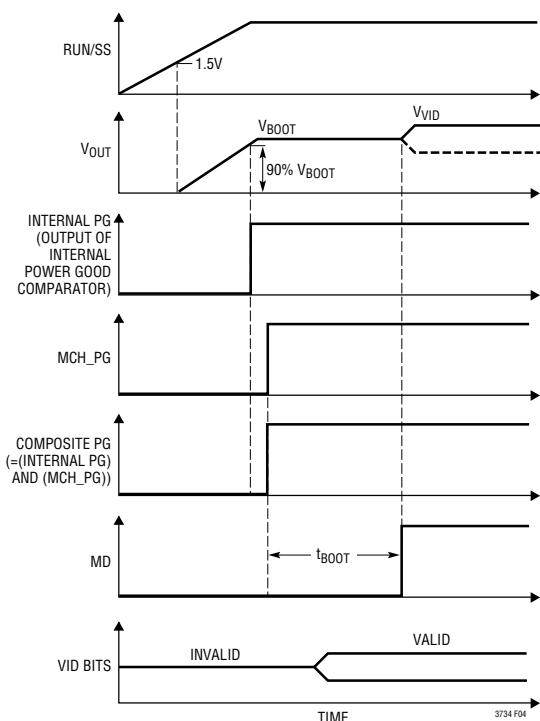

Figure 4. Start-Up Timing Diagram

Output Voltage Set in Deep Sleep and Deeper Sleep States (Refer to the Functional Diagram)

The output voltage can be offset by the STP_CPUB signal. When STP_CPUB becomes low, the output voltage will be a certain percentage lower than that set by the VID bits in Table 1. This state is defined to be the deep sleep state. Referring to the Functional Diagram, we can calculate the STP_CPUB offset to be:

$$\text{STP}\% = -\frac{R3}{R3 + R4} \cdot 100\%$$

By using different R4 resistors, STP_CPUB offset can be programmed.

The output voltage could also be set by external resistors R4 and R6 when DPRSLPVR input is high. This state is defined to be the deeper sleep state. The output voltage is set to V_{DPRSLPVR} , regardless of the VID setting:

$$V_{\text{DPRSLPVR}} = 0.6V \cdot \frac{R2 \cdot (R3 + R6 \parallel R4)}{(R6 \parallel R4) \cdot (R1 + R2)}$$

Where $R6 \parallel R4$ is the parallel combination of R4 and R6.

By using different value R6 resistors, V_{DPRSLPVR} can be programmed.

(The digital input threshold voltage is 1.8V for STP_CPUB, DPRSLPVR and MCH_PG inputs.)

Power Good Masking

The PGOOD output monitors V_{OUT} . When V_{OUT} is not within $\pm 10\%$ of the set point, PGOOD is pulled low with an internal MOSFET. When V_{OUT} is within the regulation window, PGOOD is of high impedance. PGOOD should be pulled up by an external resistor.

During VID changes, deep sleep and deeper sleep transitions, the output voltage can initially be out of the $\pm 10\%$ window of the newly set regulation point. To avoid nuisance indications from PGOOD, a timer masks PGOOD for $110\mu\text{s}$. If output is still out of regulation after this blanking time, PGOOD goes low. Any overvoltage or undervoltage condition is also masked for $110\mu\text{s}$ before it is reported by PGOOD.

The masking circuitry also adaptively tracks VID and state changes. If a new change in VID or state happens before the $110\mu\text{s}$ masking timer expires, the timer resets and starts a fresh count of $110\mu\text{s}$. This prevents the system from rebooting under frequent output voltage transitions. Refer to Figure 5 for the PGOOD timing diagram.

During start up, PGOOD is actively pulled low until the RUN/SS pin voltage reaches its arming voltage, which is

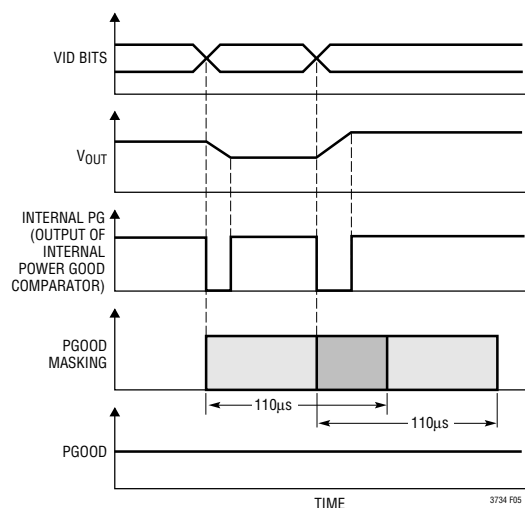

Figure 5. PGOOD Timing Diagram

APPLICATIONS INFORMATION

Table 1. VID Output Voltage Programming

VID5	VID4	VID3	VID2	VID1	VID0	LTC3734
0	0	0	0	0	0	1.708V
0	0	0	0	0	1	1.692V
0	0	0	0	1	0	1.676V
0	0	0	0	1	1	1.660V
0	0	0	1	0	0	1.644V
0	0	0	1	0	1	1.628V
0	0	0	1	1	0	1.612V
0	0	0	1	1	1	1.596V
0	0	1	0	0	0	1.580V
0	0	1	0	0	1	1.564V
0	0	1	0	1	0	1.548V
0	0	1	0	1	1	1.532V
0	0	1	1	0	0	1.516V
0	0	1	1	0	1	1.500V
0	0	1	1	1	0	1.484V
0	0	1	1	1	1	1.468V
0	1	0	0	0	0	1.452V
0	1	0	0	0	1	1.436V
0	1	0	0	1	0	1.420V
0	1	0	0	1	1	1.404V
0	1	0	1	0	0	1.388V
0	1	0	1	0	1	1.372V
0	1	0	1	1	0	1.356V
0	1	0	1	1	1	1.340V
0	1	1	0	0	0	1.324V
0	1	1	0	0	1	1.308V
0	1	1	0	1	0	1.292V
0	1	1	0	1	1	1.276V
0	1	1	1	0	0	1.260V
0	1	1	1	0	1	1.244V
0	1	1	1	1	0	1.228V
0	1	1	1	1	1	1.212V

VID5	VID4	VID3	VID2	VID1	VID0	LTC3734
1	0	0	0	0	0	1.196V
1	0	0	0	0	1	1.180V
1	0	0	0	1	0	1.164V
1	0	0	0	1	1	1.148V
1	0	0	1	0	0	1.132V
1	0	0	1	0	1	1.116V
1	0	0	1	1	0	1.100V
1	0	0	1	1	1	1.084V
1	0	1	0	0	0	1.068V
1	0	1	0	0	1	1.052V
1	0	1	0	1	0	1.036V
1	0	1	0	1	1	1.020V
1	0	1	1	0	0	1.004V
1	0	1	1	0	1	0.988V
1	0	1	1	1	0	0.972V
1	0	1	1	1	1	0.956V
1	1	0	0	0	0	0.940V
1	1	0	0	0	1	0.924V
1	1	0	0	1	0	0.908V
1	1	0	0	1	1	0.892V
1	1	0	1	0	0	0.876V
1	1	0	1	0	1	0.860V
1	1	0	1	1	0	0.844V
1	1	0	1	1	1	0.828V
1	1	1	0	0	0	0.812V
1	1	1	0	0	1	0.796V
1	1	1	0	1	0	0.780V
1	1	1	0	1	1	0.764V
1	1	1	1	0	0	0.748V
1	1	1	1	0	1	0.732V
1	1	1	1	1	0	0.716V
1	1	1	1	1	1	0.700V

4.2V typically. Only then is the PGOOD pull-low signal released.

When RUN/SS goes low, PGOOD goes low simultaneously.

Fault Conditions: Overcurrent Latchoff

The RUN/SS pin also provides the ability to latch off the controller when an overcurrent condition is detected. The

RUN/SS capacitor, C_{SS} , is used initially to limit the inrush current. After the controller has been started and been given adequate time to charge up the output capacitors and provide full load current, the RUN/SS capacitor is used for a short-circuit timer. If the output voltage falls to less than 70% of its nominal value after C_{SS} reaches 4.2V, C_{SS} begins discharging on the assumption that the output is in an overcurrent condition. If the condition lasts for a long

APPLICATIONS INFORMATION

enough period as determined by the size of the C_{SS} , the controller will be shut down until the RUN/SS pin voltage is recycled. If the overload occurs during start-up, the time can be approximated by:

$$t_{LO}^1 \approx (C_{SS} \cdot 0.7V)/(1.5\mu A) = 4.6 \cdot 10^5 (C_{SS})$$

If the overload occurs after start-up, the voltage on C_{SS} will continue charging and will provide additional time before latching off:

$$t_{LO}^2 \approx (C_{SS} \cdot 2V)/(1.5\mu A) = 1.3 \cdot 10^6 (C_{SS})$$

This built-in overcurrent latchoff can be overridden by providing a pull-up resistor, R_{SS} , to the RUN/SS pin as shown in Figure 3. This resistance shortens the soft-start period and prevents the discharge of the RUN/SS capacitor during a severe overcurrent and/or short-circuit condition. When deriving the $5\mu A$ current from PV_{CC} as in the figure, current latchoff is always defeated.

Why should you defeat current latchoff? During the prototyping stage of a design, there may be a problem with noise pickup or poor layout causing the protection circuit to latch off the controller. Defeating this feature allows troubleshooting of the circuit and PC layout. The internal short-circuit and foldback current limiting still remains active, thereby protecting the power supply system from failure. A decision can be made after the design is complete whether to rely solely on foldback current limiting or to enable the latchoff feature by removing the pull-up resistor.

The value of the soft-start capacitor C_{SS} may need to be scaled with output voltage, output capacitance and load current characteristics. The minimum soft-start capacitance is given by:

$$C_{SS} > (C_{OUT})(V_{OUT})(10^{-4})(R_{SENSE})$$

A recommended soft-start capacitor of $C_{SS} = 0.1\mu F$ will be sufficient for most applications.

Minimum On-Time Considerations

Minimum on-time, $t_{ON(MIN)}$, is the smallest time duration that the LTC3734 is capable of turning on the top MOSFET. It is determined by internal timing delays and the gate

charge required to turn on the top MOSFET. Low duty cycle applications may approach this minimum on-time limit and care should be taken to ensure that:

$$t_{ON(MIN)} < \frac{V_{OUT}}{V_{IN}(f)}$$

If the duty cycle falls below what can be accommodated by the minimum on-time, the LTC3734 will begin to skip cycles resulting in variable frequency operation. The output voltage will continue to be regulated, but the ripple current and ripple voltage will increase.

The minimum on-time for the LTC3734 is generally less than 150ns. However, as the peak sense voltage decreases, the minimum on-time gradually increases. This is of particular concern in forced continuous applications with low ripple current at light loads. If the duty cycle drops below the minimum on-time limit in this situation, a significant amount of cycle skipping can occur with correspondingly larger ripple current and ripple voltage.

If an application can operate close to the minimum on-time limit, an inductor must be chosen that has a low enough inductance to provide sufficient ripple amplitude to meet the minimum on-time requirement. *As a general rule, keep the inductor ripple current equal to or greater than 15% of $I_{OUT(MAX)}$ at $V_{IN(MAX)}$.*

Active Voltage Positioning

Active voltage positioning can be used to minimize peak-to-peak output voltage excursion under worst-case transient loading conditions. The open-loop DC gain of the control loop is reduced depending upon the maximum load step specifications. Active voltage positioning can easily be added to the LTC3734. Figure 6 shows the equivalent circuit for implementing AVP. The load line slope is estimated to be:

$$AVP \approx -35.5 \cdot \frac{R_{SENSE}}{m} \cdot \frac{R3}{R_{AVP}}, \quad (9)$$

$$\text{if } g_m \cdot R3 > 10 \cdot \frac{V_{OUT}}{0.6V}$$

APPLICATIONS INFORMATION

where

AVP is the slope, in mV/A

R_{SENSE} is the current sense resistor

m is the number of phases, m = 1 for LTC3734

R₃ and R_{AVP} are defined in Figure 6

g_m is the transconductance gain for the error amplifier, it is about 4.5mmho for LTC3734.

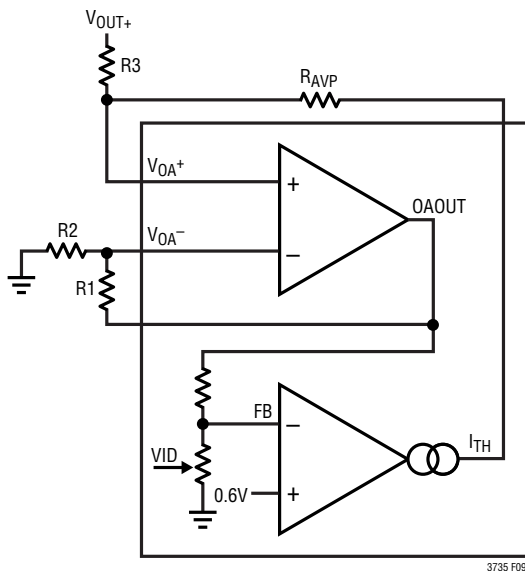

Figure 6. Simplified Schematic Diagram for AVP Design in LTC3734

Rewriting equation (9) we can estimate the AVP resistor to be:

$$R_{AVP} \cong \frac{35.5 \cdot R_3 \cdot R_{SENSE}}{m \cdot |AVP|} \quad (10)$$

We also adopt the current sense resistors as part of voltage positioning slopes. So the total load line slope is estimated to be:

$$AVP \cong -35.5 \cdot \frac{R_{SENSE}}{m} \cdot \frac{R_3}{R_{AVP}} - \frac{R_{SENSE}}{m}, \quad (11)$$

if $g_m \cdot R_3 \gg \frac{V_{OUT}}{0.6V}$

Rewriting this equation, we can estimate the R_{AVP} value to be:

$$R_{AVP} \cong \frac{35.5 \cdot R_3}{\frac{m \cdot |AVP|}{R_{SENSE}} - 1} \quad (12)$$

Typically the calculation results based on these equations have ±10% tolerance. So the resistor values need to be fine tuned.

Efficiency Considerations

The percent efficiency of a switching regulator is equal to the output power divided by the input power times 100%. It is often useful to analyze individual losses to determine what is limiting the efficiency and which change would produce the most improvement. Percent efficiency can be expressed as:

$$\% \text{Efficiency} = 100\% - (L_1 + L_2 + L_3 + \dots)$$

where L₁, L₂, etc. are the individual losses as a percentage of input power.

Although all dissipative elements in the circuit produce losses, four main sources usually account for most of the losses in LTC3734 circuits: 1) I²R losses, 2) Topside MOSFET transition losses, 3) P_{VCC} supply current and 4) C_{IN} loss.

1) I²R losses are predicted from the DC resistances of the fuse (if used), MOSFET, inductor, and current sense resistor. In continuous mode the average output current flows through L and R_{SENSE}, but is “chopped” between the topside MOSFET and the synchronous MOSFET. If the two MOSFETs have approximately the same R_{DS(ON)}, then the resistance of one MOSFET can simply be summed with the resistances of L, R_{SENSE} and ESR to obtain I²R losses. For example, if each R_{DS(ON)} = 10mΩ, R_L = 10mΩ, and R_{SENSE} = 5mΩ, then the total resistance is 25mΩ. This results in losses ranging from 2% to 8% as the output current increases from 3A to 15A per output stage for a 5V output, or a 3% to 12% loss per output stage for a 3.3V output.

APPLICATIONS INFORMATION

Efficiency varies as the inverse square of V_{OUT} for the same external components and output power level. The combined effects of increasingly lower output voltages and higher currents required by high performance digital systems is not doubling but quadrupling the importance of loss terms in the switching regulator system!

2) Transition losses apply only to the topside MOSFET(s), and are significant only when operating at high input voltages (typically 12V or greater). Transition losses can be estimated from:

$$\text{Transition Loss} = V_{IN}^2 \cdot \frac{I_{OUT}}{2} \cdot f \cdot C_{RSS} \cdot R_{DR} \cdot \left(\frac{1}{V_{DR} - V_{TH(MIN)}} + \frac{1}{V_{TH(MIN)}} \right)$$

3) PV_{CC} drives both top and bottom MOSFETs. The MOSFET driver current results from switching the gate capacitance of the power MOSFETs. Each time a MOSFET gate is switched from low to high to low again, a packet of charge dQ moves from PV_{CC} to ground. The resulting dQ/dt is a current out of PV_{CC} that is typically much larger than the control circuit current. In continuous mode, $I_{GATECHG} = (Q_T + Q_B)f$, where Q_T and Q_B are the gate charges of the topside and bottom side MOSFETs and f is the switching frequency.

4) The input capacitor has the difficult job of filtering the large RMS input current to the regulator. It must have a very low ESR to minimize the AC I^2R loss and sufficient capacitance to prevent the RMS current from causing additional upstream losses in fuses or batteries.

Other losses, including C_{OUT} ESR loss, Schottky diode conduction loss during dead time, inductor core loss and internal control circuitry supply current generally account for less than 2% additional loss.

Checking Transient Response

The regulator loop response can be checked by looking at the load transient response. Switching regulators take several cycles to respond to a step in DC (resistive) load current. When a load step occurs, V_{OUT} shifts by an amount equal to $\Delta I_{LOAD}(ESR)$, where ESR is the effective

series resistance of C_{OUT} . ΔI_{LOAD} also begins to charge or discharge C_{OUT} generating the feedback error signal that forces the regulator to adapt to the current change and return V_{OUT} to its steady-state value. During this recovery time V_{OUT} can be monitored for excessive overshoot or ringing, which would indicate a stability problem. *The availability of the I_{TH} pin not only allows optimization of control loop behavior but also provides a DC coupled and AC filtered closed loop response test point. The DC step, rise time, and settling at this test point truly reflects the closed loop response.* Assuming a predominantly second order system, phase margin and/or damping factor can be estimated using the percentage of overshoot seen at this pin. The bandwidth can also be estimated by examining the rise time at the pin. The I_{TH} external components shown in the Figure 1 circuit will provide an adequate starting point for most applications.

The I_{TH} series R_C - C_C filter sets the dominant pole-zero loop compensation. The values can be modified slightly (from 0.2 to 5 times their suggested values) to optimize transient response once the final PC layout is done and the particular output capacitor type and value have been determined. The output capacitors need to be decided upon first because the various types and values determine the loop gain and phase. An output current pulse of 20% to 80% of full-load current having a rise time of $<1\mu s$ will produce output voltage and I_{TH} pin waveforms that will give a sense of the overall loop stability without breaking the feedback loop. The initial output voltage step resulting from the step change in output current may not be within the bandwidth of the feedback loop, so this signal cannot be used to determine phase margin. This is why it is better to look at the I_{TH} pin signal which is in the feedback loop and is the filtered and compensated control loop response. The gain of the loop will be increased by increasing R_C and the bandwidth of the loop will be increased by decreasing C_C . If R_C is increased by the same factor that C_C is decreased, the zero frequency will be kept the same, thereby keeping the phase the same in the most critical frequency range of the feedback loop. The output voltage settling behavior is related to the stability of the closed-loop system and will demonstrate the actual overall supply performance.

APPLICATIONS INFORMATION

Automotive Considerations: Plugging into the Cigarette Lighter

As battery-powered devices go mobile, there is a natural interest in plugging into the cigarette lighter in order to conserve or even recharge battery packs during operation. But before you connect, be advised: you are plugging into the supply from hell. The main battery line in an automobile is the source of a number of nasty potential transients, including load-dump, reverse-battery and double-battery.

Load-dump is the result of a loose battery cable. When the cable breaks connection, the field collapse in the alternator can cause a positive spike as high as 60V which takes several hundred milliseconds to decay. Reverse-battery is just what it says, while double-battery is a consequence of tow truck operators finding that a 24V jump start cranks cold engines faster than 12V.

The network shown in Figure 7 is the most straightforward approach to protect a DC/DC converter from the ravages of an automotive power line. The series diode prevents current from flowing during reverse-battery, while the transient suppressor clamps the input voltage during load-dump. Note that the transient suppressor should not conduct during double-battery operation, but must still clamp the input voltage below breakdown of the converter. Although the LTC3734 has a maximum input voltage of 32V, most applications will be limited to 30V by the MOSFET BV_{DSS} .

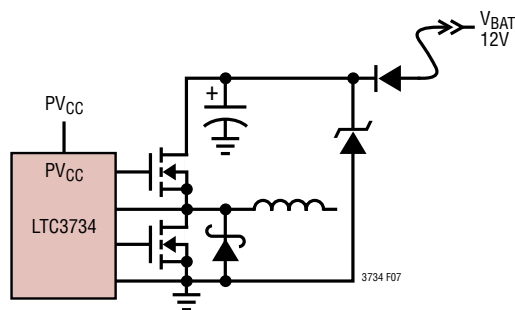

Figure 7. Automotive Application Protection

Design Example

As a design example, assume $V_{IN} = 12V$ (nominal), $V_{IN} = 21V$ (max), $V_{OUT} = 1.5V$, $I_{MAX} = 20A$, and $f = 350kHz$.

The inductance value is chosen first based on a 40% ripple current assumption. The highest value of ripple current occurs at the maximum input voltage. The minimum inductance for 40% ripple current is:

$$L \geq \frac{V_{OUT}}{f \cdot \Delta I} \cdot \left(1 - \frac{V_{OUT}}{V_{IN}}\right) = \frac{1.5V}{350kHz \cdot (40\% \cdot 20A)} \cdot \left(1 - \frac{1.5V}{21V}\right) = 0.5\mu H$$

The peak inductor current will be the maximum DC current plus one half of the ripple current, or 24A.

Tie the FREQSET pin to 1.2V, resistively divided down from SV_{CC} to have 350kHz operation.

The minimum on-time also occurs at maximum input voltage:

$$t_{ON(MIN)} = \frac{V_{OUT}}{V_{IN} \cdot f} = \frac{1.5V}{21V \cdot 350kHz} = 204ns$$

which is larger than 150ns, the typical minimum on time of the LTC3734.

R_{SENSE} can be calculated by using a conservative maximum sense voltage threshold of 40mV and taking into account of the peak current:

$$R_{SENSE} = \frac{40mV}{24A} = 0.002\Omega$$

The power loss dissipated by the top MOSFET can be calculated with equations 3 and 7. Using a Fairchild FDS7760 as an example: $R_{DS(ON)} = 8m\Omega$, $Q_G = 55nC$ at 5V V_{GS} , $C_{RSS} = 307pF$, $V_{TH(MIN)} = 1V$. At maximum input

APPLICATIONS INFORMATION

voltage with T_J (estimated) = 85°C at an elevated ambient temperature:

$$P_{TOP} = \frac{1.5V}{21V} \cdot 20A^2 \cdot (1 + 0.005 \cdot (85^\circ C - 25^\circ C)) \cdot 0.008\Omega + 21V^2 \cdot \frac{20A}{2} \cdot 350kHz \cdot 307pF \cdot 2\Omega \cdot \left(\frac{1}{5V - 1V} + \frac{1}{1V} \right) = 1.48W$$

Equation 4 gives the worst-case power loss dissipated by the bottom MOSFET (assuming FDS7760 and $T_J = 85^\circ C$ again):

$$P_{BOT} = \frac{21V - 1.5V}{21V} \cdot 20A^2 \cdot (1 + 0.005 \cdot (85^\circ C - 25^\circ C)) \cdot 0.008\Omega = 3.86W$$

Therefore, it is necessary to have two FDS7760s in parallel to split the power loss for both the top and bottom MOSFETS.

A short-circuit to ground will result in a folded back current of about:

$$I_{SC} = \frac{25mV}{0.002\Omega} + \frac{1}{2} \cdot \left(\frac{200ns \cdot 21V}{0.5\mu H} \right) = 16.7A$$

The worst-case power dissipation by the bottom MOSFET under short-circuit conditions is:

$$P_{BOT} = \frac{\frac{1}{350kHz} - 200ns}{1} \cdot 16.7A^2 \cdot (1 + 0.005 \cdot (85^\circ C - 25^\circ C)) \cdot 0.008\Omega = 2.7W$$

which is less than normal, full load conditions.

The RMS input ripple current will be:

$$I_{INRMS} = 20A/2 = 10A$$

An input capacitor(s) with a 10A RMS current rating is required.

The output capacitor ripple current is calculated. The output ripple will be highest at the maximum input voltage:

$$\Delta I_{OUT(MAX)} = \frac{1.5V}{350kHz \cdot 0.5\mu H} \cdot \left(1 - \frac{1.5}{2.1} \right) = 8A_{P-P}$$

Assuming the ESR of output capacitor(s) is 5mΩ, the output ripple voltage is:

$$\Delta V_{OUT} \approx 8A_{P-P} \left(5m\Omega + \frac{1}{8 \cdot 350kHz \cdot (4 \cdot 270\mu F)} \right) = 42.6mV_{P-P}$$

APPLICATIONS INFORMATION

PC Board Layout Checklist

When laying out the printed circuit board, the following checklist should be used to ensure proper operation of the LTC3734. Check the following in your layout:

1) Are the signal and power grounds segregated? Keep the SGND at one end of a PC board to prevent MOSFET currents from traveling under the IC. The IC signal ground pin (Pin 5) should be used to hook up all control circuitry on one side of the IC, routing the copper through SGND, under the IC covering the “shadow” of the package, connecting to the PGND pin (Pin 20) and then continuing on to the (–) plate of C_{OUT} .

2) Is the PV_{CC} decoupling capacitor connected immediately adjacent to the PV_{CC} and PGND pins? A $1\mu\text{F}$ ceramic capacitor of the X7R or X5R material is small enough to fit very close to the IC to minimize the ill effects of the large current pulses drawn to drive the power MOSFETs. An additional $4.7\mu\text{F} \sim 10\mu\text{F}$ of ceramic, tantalum or other low ESR capacitor is recommended in order to keep PV_{CC} stable. The power ground returns to the sources of the bottom N-channel MOSFETs, anodes of the Schottky diodes, and (–) plates of C_{IN} , which should have the shortest trace length possible.

3) Are the SENSE[–] and SENSE⁺ leads routed together with minimum PC trace spacing? The filter capacitors between SENSE⁺ and SENSE[–] pin pairs should be as close as possible to the LTC3734. Ensure accurate current sensing with Kelvin connections at the current sense resistor. See Figure 8.

4) Does the (+) plate of C_{IN} connect to the drains of the topside MOSFETs as closely as possible? This capacitor provides the AC current to the MOSFETs. Keep the input current path formed by the input capacitor, top and bottom MOSFETs, and the Schottky diode on the same side of the PC board in a tight loop to minimize conducted and radiated EMI.

5) Keep the “noisy” nodes, SW, BOOST, TG and BG away from sensitive small-signal nodes. Ideally the switch nodes should be placed at the furthest point from the LTC3734.

It is critical to keep the high-switching-current paths to a small physical size. High electric and magnetic fields will radiate from these “loops” just as radio stations transmit signals. The output capacitor ground should return to the negative terminal of the input capacitor and not share a common ground path with any switched current paths. The left half of the circuit gives rise to the “noise” generated by a switching regulator. The ground terminations of the synchronous MOSFETs and Schottky diodes should return to the negative plate(s) of the input capacitor(s) with a short isolated PC trace since very high switched currents are present. A separate isolated path from the negative plate(s) of the input capacitor(s) should be used to tie in the IC power ground pin (PGND) and the signal ground pin (SGND). This technique keeps inherent signals generated by high current pulses from taking alternate current paths that have finite impedances during the total period of the switching regulator. External OPTI-LOOP compensation allows overcompensation for PC layouts which are not optimized but this is not the recommended design procedure.

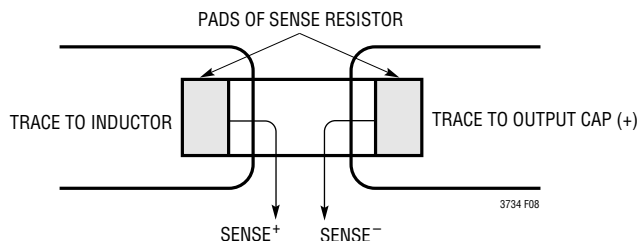

Figure 8. Proper Current Sense Connections

TYPICAL APPLICATION

Figure 9 shows a typical application using the LTC3734 to power the mobile CPU core. The input can vary from 5V to 24V; the output voltage can be programmed from 0.7V to 1.708V with a maximum current of 20A. By only modifying the external MOSFET and inductor selection, higher load current capability can be achieved.

The power supply in Figure 9 receives a VRON signal for ON/OFF control. After soft-start, the output voltage is set at 1.2V until the assertion of the MCH_PG signal. After about a 50 μ s delay, the VID5-VID0 bits gain the control over the output voltage and program it between 0.7V and

1.708V. When the STP_CPUB signal is low, a deep sleep state is indicated and the output voltage is decreased by about 1.04%. When the DPRSLPVR signal is high, a deeper sleep state is indicated and the output voltage becomes 0.748V regardless of the states of the VID bits. Active voltage positioning is accomplished with a resistive divider across the I_{TH} pin. Lower resistance yields a steeper AVP slope while higher resistance provides a flatter slope. Finally, the PGOOD output is masked for 110 μ s during VID change or state transition.

TYPICAL APPLICATION

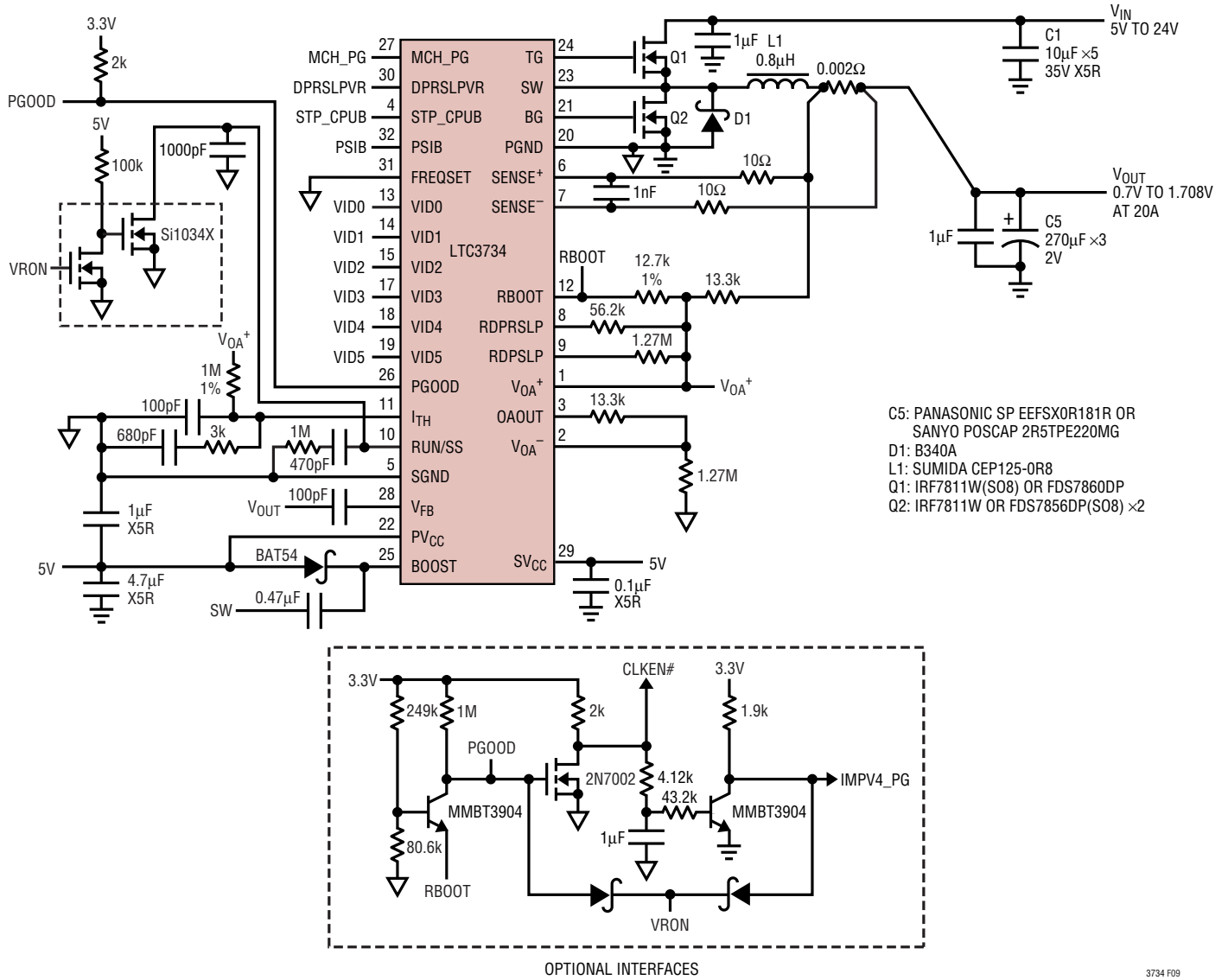
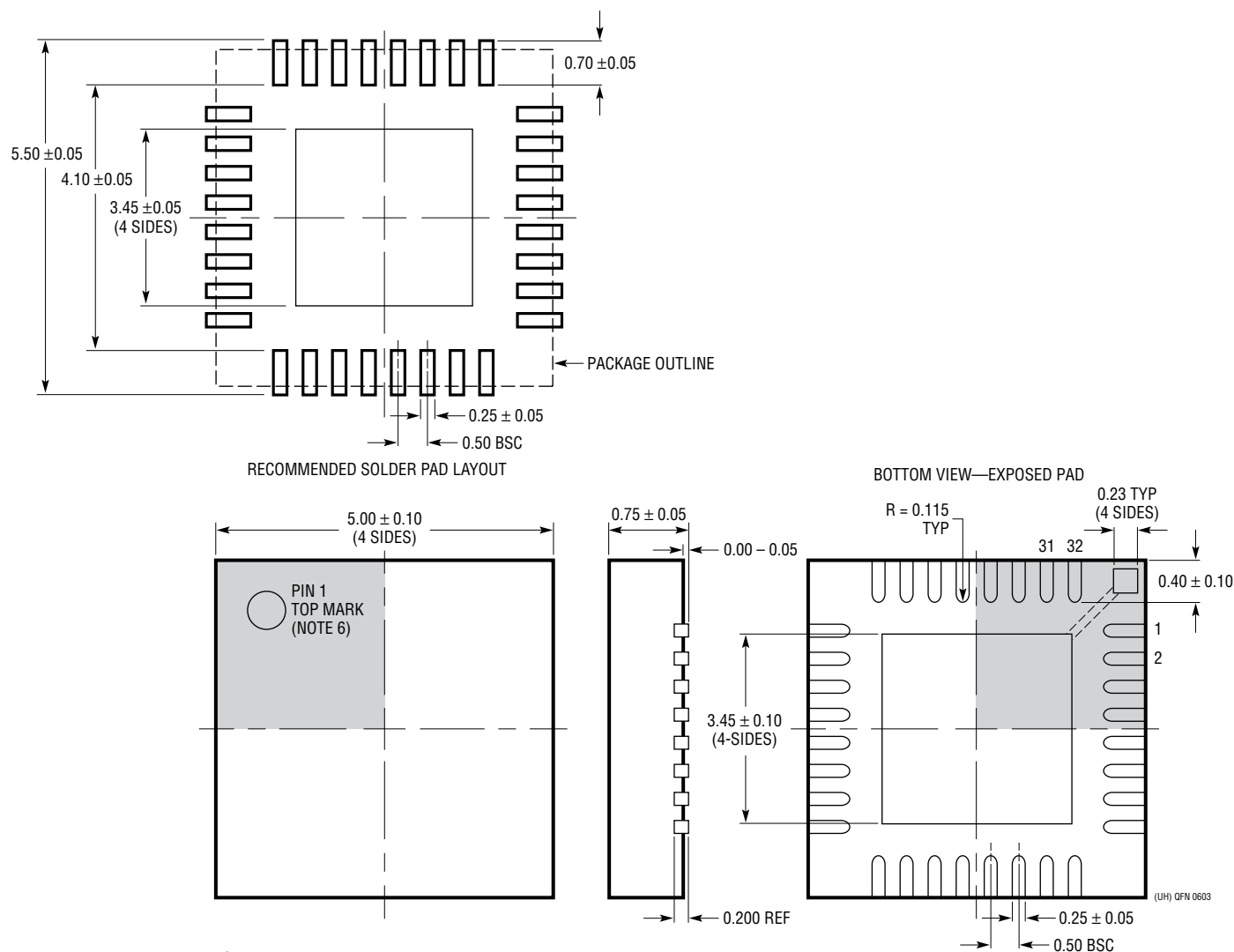

Figure 9. 5V to 24V Input, 0.7V to 1.708V Output, 20A IMVP-IV Compatible Power Supply

3734 F09

PACKAGE DESCRIPTION

UH Package 32-Lead Plastic QFN (5mm × 5mm) (Reference LTC DWG # 05-08-1693)



NOTE:

1. DRAWING PROPOSED TO BE A JEDEC PACKAGE OUTLINE M0-220 VARIATION WHHD-(X) (TO BE APPROVED)
2. DRAWING NOT TO SCALE
3. ALL DIMENSIONS ARE IN MILLIMETERS
4. DIMENSIONS OF EXPOSED PAD ON BOTTOM OF PACKAGE DO NOT INCLUDE MOLD FLASH. MOLD FLASH, IF PRESENT, SHALL NOT EXCEED 0.20mm ON ANY SIDE
5. EXPOSED PAD SHALL BE SOLDER PLATED
6. SHADED AREA IS ONLY A REFERENCE FOR PIN 1 LOCATION ON THE TOP AND BOTTOM OF PACKAGE

RELATED PARTS

PART NUMBER	DESCRIPTION	COMMENTS
LTC1530	High Power Step-Down Synchronous DC/DC Controller in SO-8	High Efficiency 5V to 3.3V Conversion at Up to 15A
LTC1628/LTC1628-PG/ LTC1628-SYNC	2-Phase, Dual Output Synchronous Step-Down DC/DC Controllers	Reduces C_{IN} and C_{OUT} , Power Good Output Signal, Synchronizable, $3.5V \leq V_{IN} \leq 36V$, I_{OUT} up to 20A, $0.8V \leq V_{OUT} \leq 5V$
LTC1629/ LTC1629-PG	20A to 200A PolyPhase Synchronous Controllers	Expandable from 2-Phase to 12-Phase, Uses All Surface Mount Components, No Heat Sink, V_{IN} up to 36V
LTC1702	No R_{SENSE}^{TM} 2-Phase Dual Synchronous Step-Down Controller	550kHz, No Sense Resistor
LTC1703	No R_{SENSE} 2-Phase Dual Synchronous Step-Down Controller with 5-Bit Mobile VID Control	Mobile Pentium® III Processors, 550kHz, $V_{IN} \leq 7V$
LTC1708-PG	2-Phase, Dual Synchronous Controller with Mobile VID	$3.5V \leq V_{IN} \leq 36V$, VID Sets V_{OUT1} , PGOOD
LT®1709/ LT1709-8	High Efficiency, 2-Phase Synchronous Step-Down Switching Regulators with 5-Bit VID	$1.3V \leq V_{OUT} \leq 3.5V$, Current Mode Ensures Accurate Current Sharing, $3.5V \leq V_{IN} \leq 36V$
LTC1735	High Efficiency Synchronous Step-Down Switching Regulator	Output Fault Protection, 16-Pin SSOP
LTC1736	High Efficiency Synchronous Controller with 5-Bit Mobile VID Control	Output Fault Protection, 24-Pin SSOP, $3.5V \leq V_{IN} \leq 36V$
LTC1778	No R_{SENSE} Current Mode Synchronous Step-Down Controller	Up to 97% Efficiency, $4V \leq V_{IN} \leq 36V$, $0.8V \leq V_{OUT} \leq (0.9)(V_{IN})$, I_{OUT} up to 20A
LTC1929/ LTC1929-PG	2-Phase Synchronous Controllers	Up to 42A, Uses All Surface Mount Components, No Heat Sinks, $3.5V \leq V_{IN} \leq 36V$
LTC3711	No R_{SENSE} Current Mode Synchronous Step-Down Controller with Digital 5-Bit Interface	Up to 97% Efficiency, Ideal for Pentium III Processors, $0.925V \leq V_{OUT} \leq 2V$, $4V \leq V_{IN} \leq 36V$, I_{OUT} up to 20A
LTC3729	20A to 200A, 550kHz PolyPhase Synchronous Controller	Expandable from 2-Phase to 12-Phase, Uses all Surface Mount Components, V_{IN} up to 36V
LTC3730	3-Phase, 5-Bit Intel Mobile VID 600kHz Synchronous Step-Down Controller	$0.6V \leq V_{OUT} \leq 1.75V$, IMVP3 Compatible Up to 60A Output Current, Integrated MOSFET Drivers
LTC3731	3-Phase 600kHz Synchronous Step-Down Controller	$0.6V \leq V_{OUT} \leq 6V$, $4.5V \leq V_{IN} \leq 32V$, I_{OUT} up to 60A, Integrated MOSFET Drivers
LTC3735	2-Phase DC/DC Controller for Pentium (Centrino) Processors	40A, $0.7V \leq V_{OUT} \leq 1.708V$, $4V \leq V_{IN} \leq 30V$

No R_{SENSE} is a trademark of Linear Technology Corporation. Pentium is a registered trademark of Intel Corporation.