

Low Input Voltage, High Power, No R_{SENSE}[™] Synchronous Buck DC/DC Controller

FEATURES

- Very Low V_{IN(MIN)}: 1.5V
- True Current Mode Control
- 5V Drive for N-Channel MOSFETs Eliminates Auxillary 5V Supply
- No Sense Resistor Required
- Uses Standard 5V Logic-Level N-Channel MOSFETs
- Adjustable Current Limit
- Adjustable Frequency
- Switch t_{ON(MIN)} < 100ns
- 2% to 90% Duty Cycle at 200kHz
- 0.8V ±1% Reference
- Power Good Output Voltage Monitor
- Programmable Soft-Start
- Output Overvoltage Protection
- Optional Short-Circuit Shutdown Timer
- Small 24-Lead SSOP Package

APPLICATIONS

- Telecom Card 3.3V, 2.5V, 1.8V Step-Down
- Bus Termination (DDR memory, SSTL)
- Synchronous Buck with General Purpose Boost
- Low V_{IN} Synchronous Boost

DESCRIPTION

The LTC[®]3713 is a high current, high efficiency synchronous buck switching regulator controller optimized for use with very low input supply voltages. It operates from inputs as low as 1.5V and provides a regulated output voltage from 0.8V up to (0.9)V_{IN}. The controller uses a valley current control architecture to enable high operating frequencies without requiring a sense resistor. Operating frequency is selected by an external resistor and is compensated for variations in V_{IN} and V_{OUT}. The LTC3713 uses a pair of standard 5V logic-level N-channel external MOSFETs, eliminating the need for expensive P-channel or low threshold devices.

Discontinuous mode operation provides high efficiency operation at light loads. A forced continuous control pin reduces noise and RF interference, and can assist secondary winding regulation by disabling discontinuous operation when the main output is lightly loaded. Fault protection is provided by internal foldback current limiting, an output overvoltage comparator and an optional short-circuit shutdown timer.

LT, LTC and LT are registered trademarks of Linear Technology Corporation.
No R_{SENSE} is a trademark of Linear Technology Corporation.

TYPICAL APPLICATION

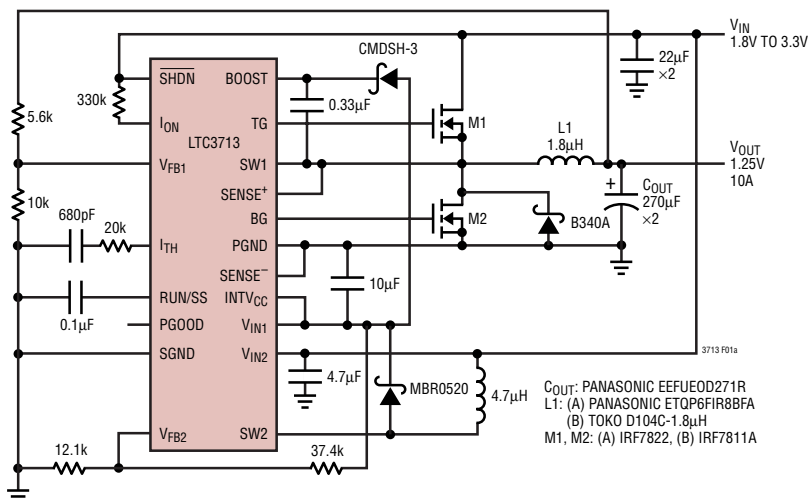
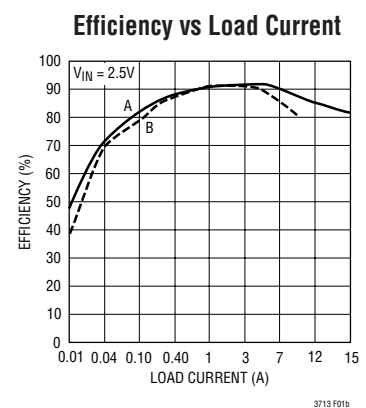

Figure 1. High Efficiency Step-Down Converter from 1.8V to 3.3V Input



ABSOLUTE MAXIMUM RATINGS

(Note 1)

Input Supply Voltage (V_{IN2})	10V to -0.3V
Boosted Topside Driver Supply Voltage (BOOST)	42V to -0.3V
V_{IN1} , I_{ON} , SW1, SENSE ⁺ Voltages	36V to -0.3V
RUN/SS, PGOOD Voltages	7V to -0.3V
FCB, V_{ON} , V_{RNG} Voltages	$INTV_{CC} + 0.3V$ to -0.3V
I_{TH} , V_{FB1} , SENSE ⁻ Voltages	2.7V to -0.3V
SW2 Voltage	36V to -0.4V
V_{FB2} Voltage	$V_{IN2} + 0.3V$
SHDN Voltage	10V
TG, BG, $INTV_{CC}$ Peak Currents	2A
TG, BG, $INTV_{CC}$ RMS Currents	50mA
Operating Ambient Temperature Range (Note 4)	-40°C to 85°C
Junction Temperature (Note 2)	125°C
Storage Temperature Range	-65°C to 150°C
Lead Temperature (Soldering, 10 sec)	300°C

PACKAGE/ORDER INFORMATION

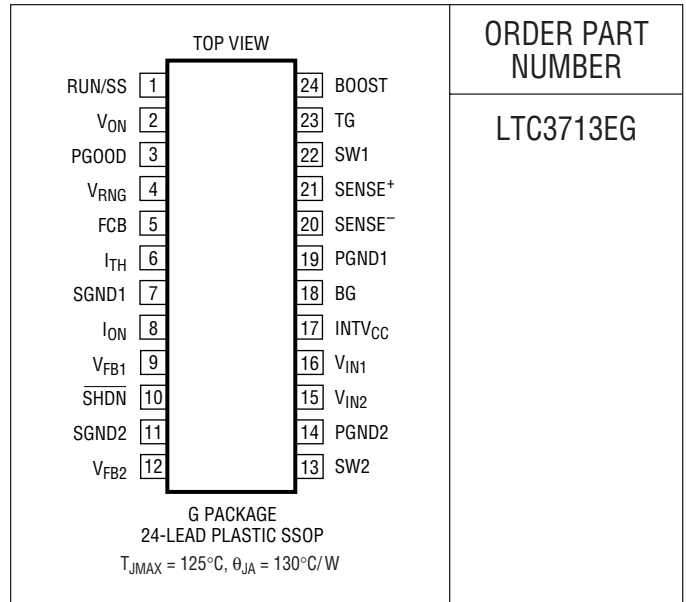

ORDER PART NUMBER

LTC3713EG

Consult LTC Marketing for parts specified with wider operating temperature ranges.

ELECTRICAL CHARACTERISTICS

The ● denotes specifications which apply over the full operating temperature range, otherwise specifications are $T_A = 25^\circ\text{C}$. $V_{IN1} = 15V$, $V_{IN2} = 1.5V$ unless otherwise noted.

SYMBOL	PARAMETER	CONDITIONS	MIN	TYP	MAX	UNITS	
Buck Regulator							
$I_{Q(VIN1)}$	Input DC Supply Current (V_{IN1}) Normal Shutdown Supply Current			900 15	2000 30	μA μA	
V_{FB1}	Feedback Reference Voltage	$I_{TH} = 1.2V$ (Note 3)	● 0.792	0.800	0.808	V	
I_{FB1}	Feedback Current	(Note 3)		-5	± 50	nA	
$\Delta V_{FB1(LINEREG)}$	Feedback Voltage Line Regulation	$V_{IN1} = 4V$ to 30V, $I_{TH} = 1.2V$ (Note 3)		0.002		%/V	
$\Delta V_{FB1(LOADREG)}$	Feedback Voltage Load Regulation	$I_{TH} = 0.5V$ to 1.9V (Note 3)	●	-0.05	-0.3	%	
$g_{m(EA)}$	Error Amplifier Transconductance	$I_{TH} = 1.2V$ (Note 3)	●	1.4	1.7	2	mS
V_{FCB}	Forced Continuous Threshold		●	0.76	0.8	0.84	V
I_{FCB}	Forced Continuous Pin Current	$V_{FCB} = 0.8V$		-1	-2	μA	
t_{ON}	On-Time	$I_{ON} = 60\mu\text{A}$, $V_{ON} = 1.5V$ $I_{ON} = 30\mu\text{A}$, $V_{ON} = 1.5V$		200 400	250 500	300 600	ns ns
$t_{ON(MIN)}$	Minimum On-Time	$I_{ON} = 180\mu\text{A}$			50	100	ns
$t_{OFF(MIN)}$	Minimum Off-Time				250	400	ns
$V_{SENSE(MAX)}$	Maximum Current Sense Threshold $V_{PGND} - V_{SW}$	$V_{RNG} = 1V$, $V_{FB1} = 0.76V$ $V_{RNG} = 0V$, $V_{FB1} = 0.76V$ $V_{RNG} = INTV_{CC}$, $V_{FB1} = 0.76V$	● ● ●	113 79 158	133 93 186	153 107 214	mV mV mV
$V_{SENSE(MIN)}$	Minimum Current Sense Threshold $V_{PGND} - V_{SW}$	$V_{RNG} = 1V$, $V_{FB1} = 0.84V$ $V_{RNG} = 0V$, $V_{FB1} = 0.84V$ $V_{RNG} = INTV_{CC}$, $V_{FB1} = 0.84V$			-67 -47 -93		mV mV mV
$\Delta V_{FB1(OV)}$	Output Overvoltage Fault Threshold			5.5	7.5	9.5	%
$\Delta V_{FB1(UV)}$	Output Undervoltage Fault Threshold			520	600	680	mV
$V_{RUN/SS(ON)}$	RUN Pin Start Threshold		●	0.8	1.5	2	V
$V_{RUN/SS(LE)}$	RUN Pin Latchoff Enable Threshold	RUN/SS Pin Rising			4	4.5	V
$V_{RUN/SS(LT)}$	RUN Pin Latchoff Threshold	RUN/SS Pin Falling			3.5	4.2	V

ELECTRICAL CHARACTERISTICS

The ● denotes specifications which apply over the full operating temperature range, otherwise specifications are $T_A = 25^\circ\text{C}$. $V_{IN1} = 15\text{V}$, $V_{IN2} = 1.5\text{V}$ unless otherwise noted.

SYMBOL	PARAMETER	CONDITIONS	MIN	TYP	MAX	UNITS
$I_{\text{RUN/SS(C)}}$	Soft-Start Charge Current	$V_{\text{RUN/SS}} = 0\text{V}$	-0.5	-1.2	-3	μA
$I_{\text{RUN/SS(D)}}$	Soft-Start Discharge Current	$V_{\text{RUN/SS}} = 4.5\text{V}$, $V_{\text{FB}} = 0\text{V}$	0.8	1.8	3	μA
UVLO	V_{IN1} Undervoltage Lockout	V_{IN1} Falling	●	3.4	3.9	V
UVLOR	V_{IN1} Undervoltage Lockout Release	V_{IN1} Rising	●	3.5	4	V
TG R_{UP}	TG Driver Pull-Up On Resistance	TG High		2	3	Ω
TG R_{DOWN}	TG Driver Pull-Down On Resistance	TG Low		2	3	Ω
BG R_{UP}	BG Driver Pull-Up On Resistance	BG High		3	4	Ω
BG R_{DOWN}	BG Driver Pull-Down On Resistance	BG Low		1	2	Ω
TG t_r	TG Rise Time	$C_{\text{LOAD}} = 3300\text{pF}$		20		ns
TG t_f	TG Fall Time	$C_{\text{LOAD}} = 3300\text{pF}$		20		ns
BG t_r	BG Rise Time	$C_{\text{LOAD}} = 3300\text{pF}$		20		ns
BG t_f	BG Fall Time	$C_{\text{LOAD}} = 3300\text{pF}$		20		ns

Internal V_{CC} Regulator

V_{INTVCC}	Internal V_{CC} Voltage	$6\text{V} < V_{\text{IN}} < 30\text{V}$	●	4.7	5	5.3	V
$\Delta V_{\text{LDO(LOADREG)}}$	Internal V_{CC} Load Regulation	$I_{\text{CC}} = 0\text{mA}$ to 20mA		-0.1	± 2		%

PGOOD Output

ΔV_{FB1H}	PGOOD Upper Threshold	V_{FB1} Rising		5.5	7.5	9.5	%
ΔV_{FB1L}	PGOOD Lower Threshold	V_{FB1} Falling		-5.5	-7.5	-9.5	%
$\Delta V_{\text{FB(HYS)}}$	PGOOD Hysteresis	V_{FB1} Returning			1	2	%
V_{PGL}	PGOOD Low Voltage	$I_{\text{PGOOD}} = 5\text{mA}$			0.15	0.4	V

Boost Regulator

$V_{\text{IN2(MIN)}}$	Minimum Operating Voltage			0.9	1.5		V
$V_{\text{IN2(MAX)}}$	Maximum Operating Voltage				10		V
$I_{\text{Q(VIN2)}}$	Input DC Supply Current (V_{IN2}) Normal Shutdown				3 0.01	4.5 1	mA μA
V_{FB2}	V_{FB2} Feedback Voltage	0°C to 70°C -40°C to 85°C	●	1.205 1.200	1.23	1.255 1.260	V V
I_{VFB2}	V_{FB2} Pin Bias Current		●		27	80	nA
$\Delta V_{\text{FB2(LINEREG)}}$	BOOST Reference Line Regulation	$1.5\text{V} \leq V_{\text{IN}} \leq 10\text{V}$			0.02	0.2	%/V
f_{BOOST}	BOOST Switching Frequency	0°C to 70°C -40°C to 85°C	●	1.0 0.9	1.4	1.8 1.9	MHz MHz
$\text{DC}_{\text{BOOST(MAX)}}$	BOOST Maximum Duty Cycle			82	86		%
$I_{\text{LIM(BOOST)}}$	BOOST Switch Current Limit	(Note 5)		500	800		mA
$V_{\text{CESAT(BOOST)}}$	BOOST Switch V_{CESAT}	$I_{\text{SW}} = 300\text{mA}$			300	350	mV
$I_{\text{SWLKG(BOOST)}}$	BOOST Switch Leakage Current	$V_{\text{SW}} = 5\text{V}$			0.01	1	μA
$V_{\text{SHDN(HIGH)}}$	$\overline{\text{SHDN}}$ Input Voltage High			1			V
$V_{\text{SHDN(LOW)}}$	$\overline{\text{SHDN}}$ Input Voltage Low					0.3	V
I_{SHDN}	$\overline{\text{SHDN}}$ Pin Bias Current	$V_{\text{SHDN}} = 3\text{V}$ $V_{\text{SHDN}} = 0\text{V}$			25 0.01	50 0.1	μA μA

Note 1: Absolute Maximum Ratings are those values beyond which the life of a device may be impaired.

Note 2: T_J is calculated from the ambient temperature T_A and power dissipation P_D as follows:

$$LTC3713EG: T_J = T_A + (P_D \cdot 130^\circ\text{C/W})$$

Note 3: The LTC3713 is tested in a feedback loop that adjusts V_{FB} to

achieve a specified error amplifier output voltage (I_{TH}).

Note 4: The LTC3713E is guaranteed to meet performance specifications from 0°C to 70°C . Specifications over the -40°C to 85°C operating temperature range are assured by design, characterization and correlation with statistical process controls.

Note 5: Current limit guaranteed by design and/or correlation to static test.

TYPICAL PERFORMANCE CHARACTERISTICS

Transient Response

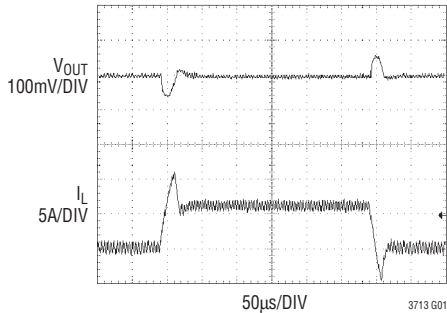

LOAD STEP 0A TO 6A
 $V_{IN} = 3.3V$
 $V_{OUT} = 1.25V$
 $FCB = 0V$
 FIGURE 1 CIRCUIT

Transient Response (Discontinuous Mode)

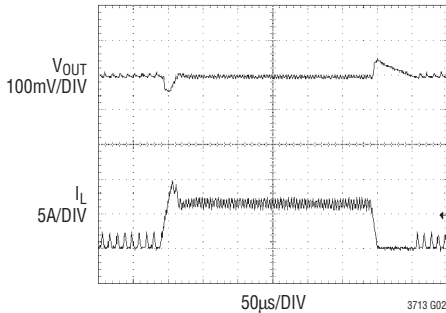

LOAD STEP 600mA TO 6A
 $V_{IN} = 3.3V$
 $V_{OUT} = 1.25V$
 $FCB = INTV_{CC}$
 FIGURE 1 CIRCUIT

Start-Up from Shutdown

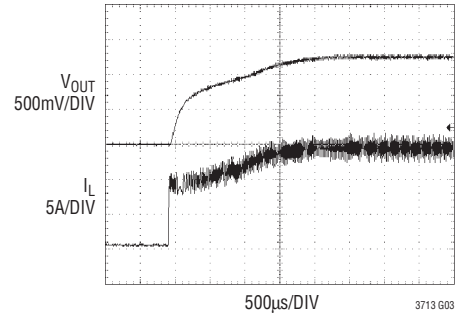

$V_{IN} = 3.3V$
 $V_{OUT} = 1.25V$
 $L = 1.8\mu H$
 $C_{OUT} = 540\mu F$
 $LOAD = 0.2\Omega$

Boost Converter Oscillator Frequency vs Temperature

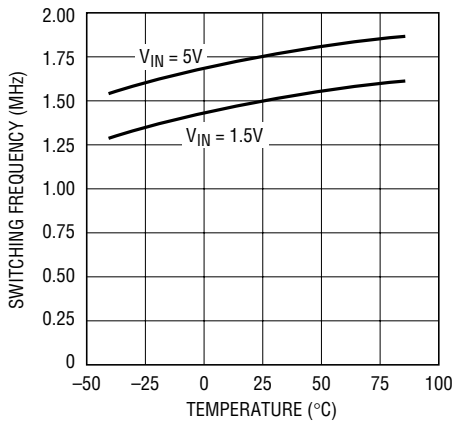

3713 G04

SHDN Pin Current vs V_{SHDN}

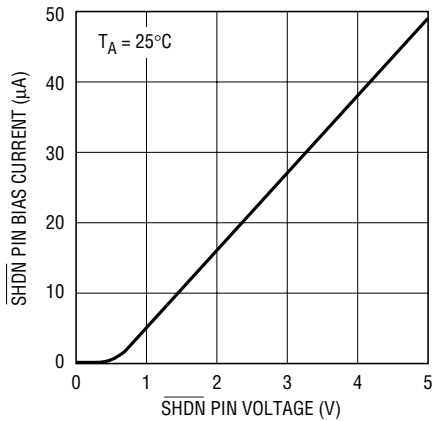

3713 G05

Boost Converter Current Limit vs Duty Cycle

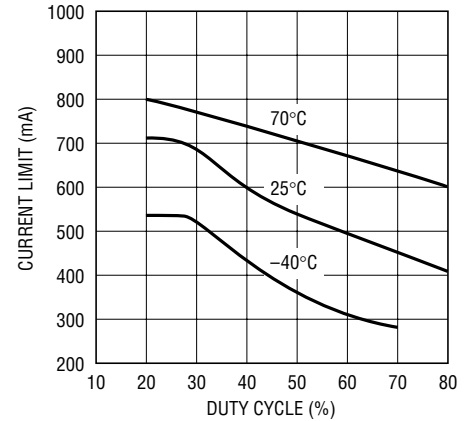

3713 G06

V_{FB2} , Feedback Pin Voltage

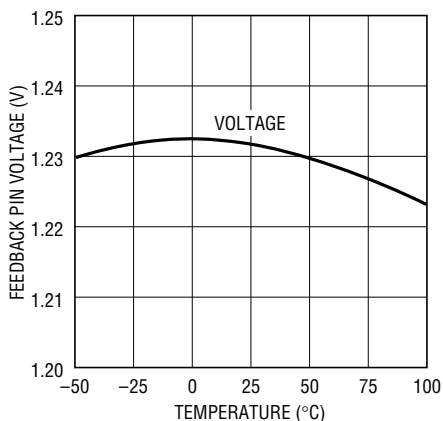

3713 G07

Efficiency vs Load Current (Discontinuous Mode)

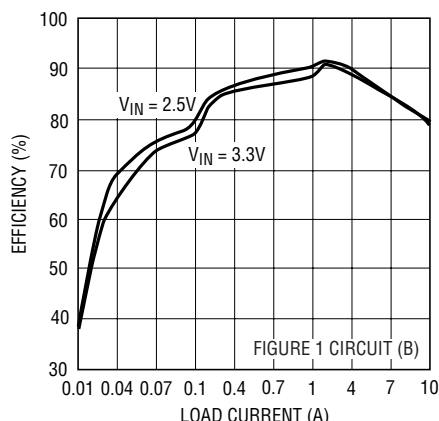

1713 G09

Efficiency vs Load Current (Force Continuous)

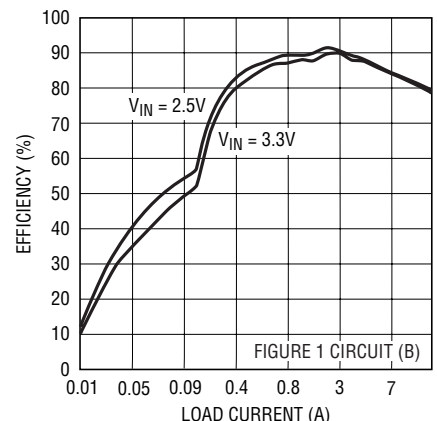

3713 G10

TYPICAL PERFORMANCE CHARACTERISTICS

Load Regulation

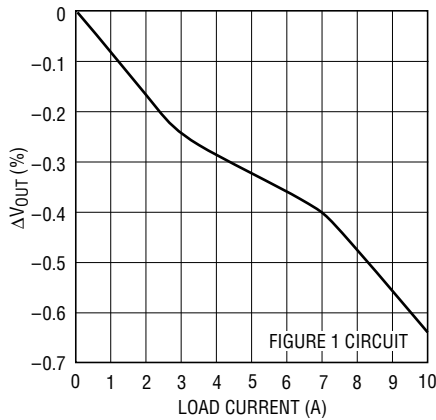

3713 G11

Frequency vs Input Voltage

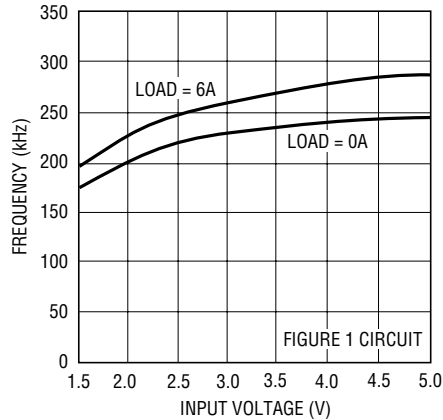

3713 G12

On-Time vs I_{ON} Current

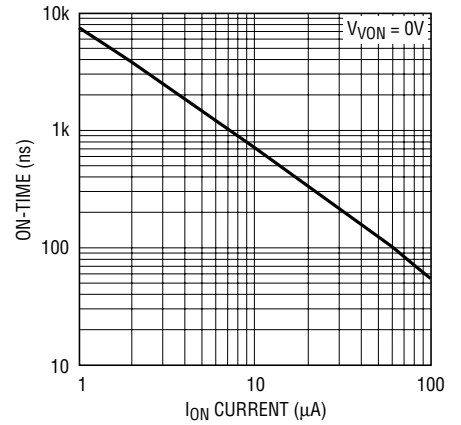

3713 G13

On-Time vs V_{ON} Voltage

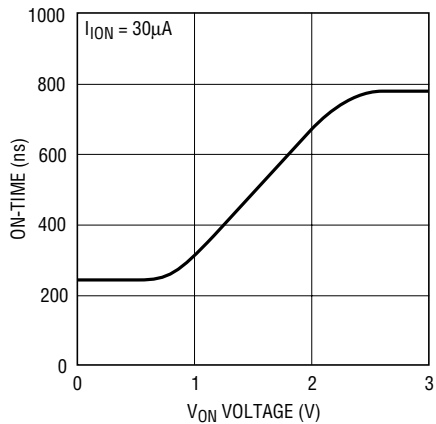

3713 G14

On-Time vs Temperature

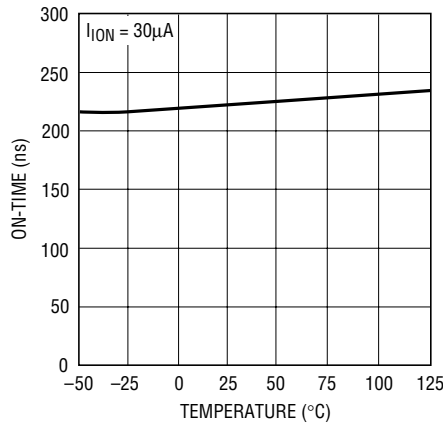

3713 G15

Current Limit Foldback

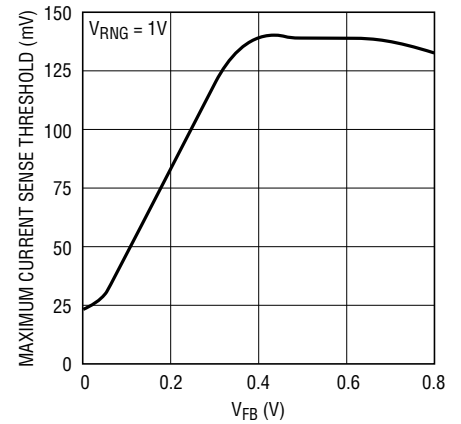

3713 G16

Maximum Current Sense Threshold vs V_{RNG} Voltage

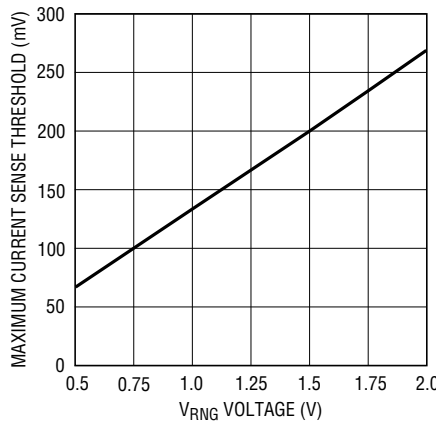

3713 G17

Maximum Current Sense Threshold vs RUN/SS Voltage

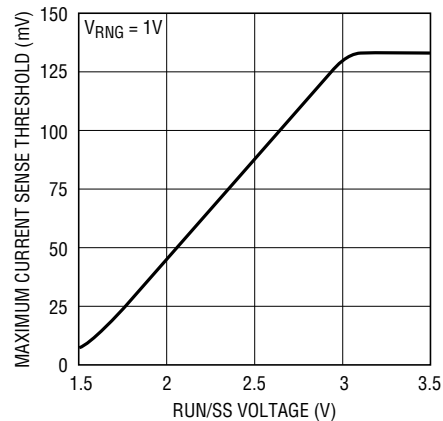

3713 G18

Maximum Current Sense Threshold vs Temperature

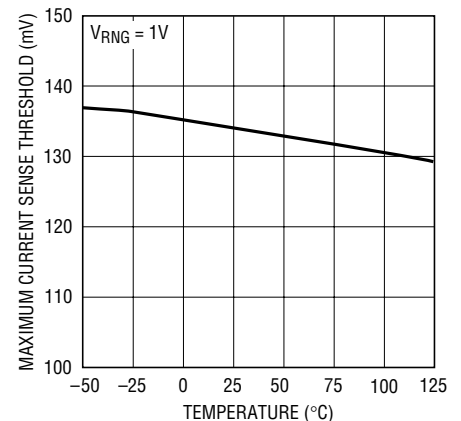

3713 G19

TYPICAL PERFORMANCE CHARACTERISTICS

Feedback Reference Voltage vs Temperature

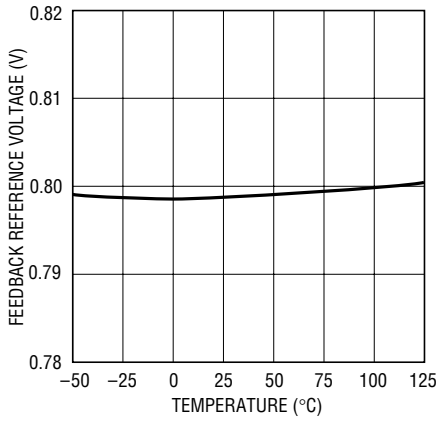

3713 G20

Error Amplifier g_m vs Temperature

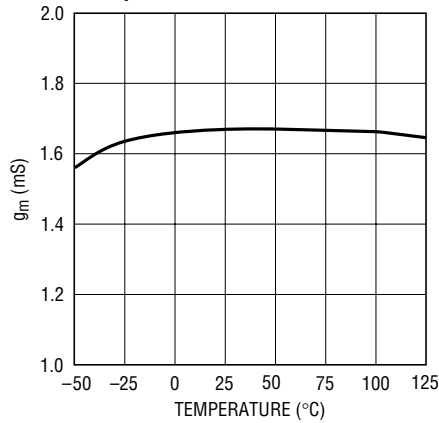

3713 G21

INTV_{CC} Load Regulation

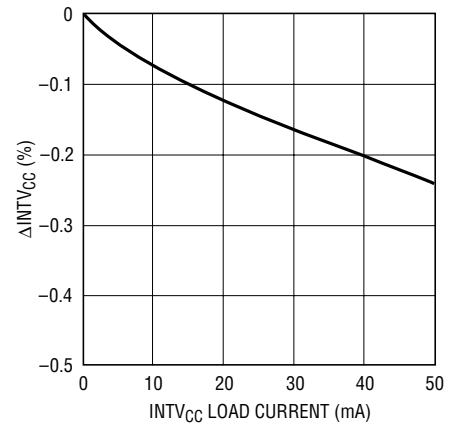

3713 G22

Current Sense Threshold vs I_{TH} Voltage

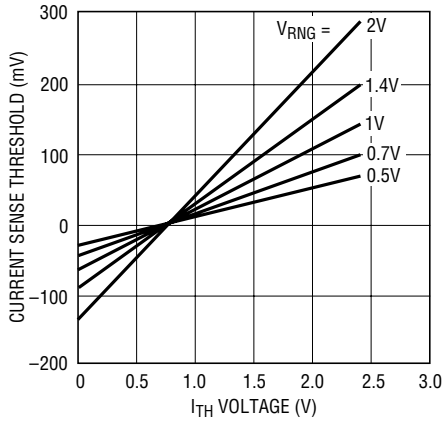

3713 G23

FCB Pin Current vs Temperature

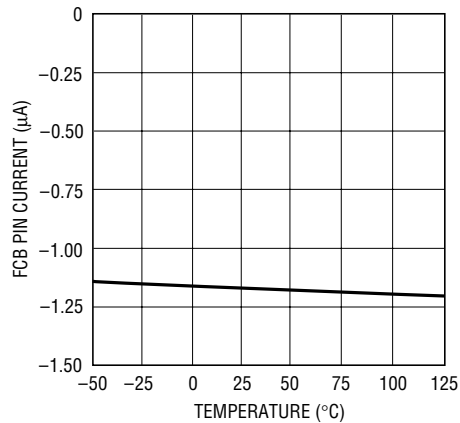

3713 G24

RUN/SS Pin Current vs Temperature

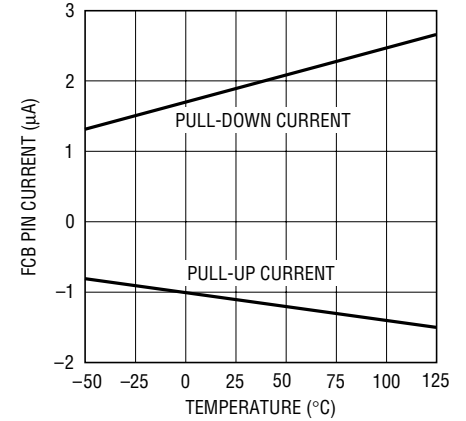

3713 G25

RUN/SS Latchoff Thresholds vs Temperature

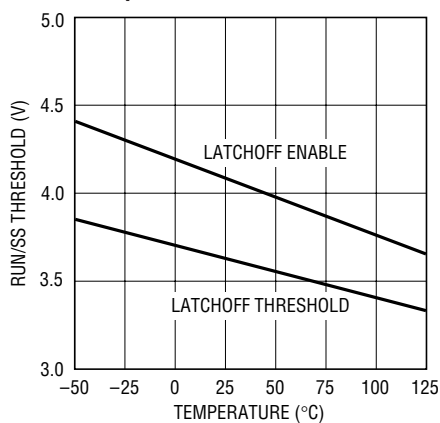

3713 G26

Undervoltage Lockout Threshold vs Temperature

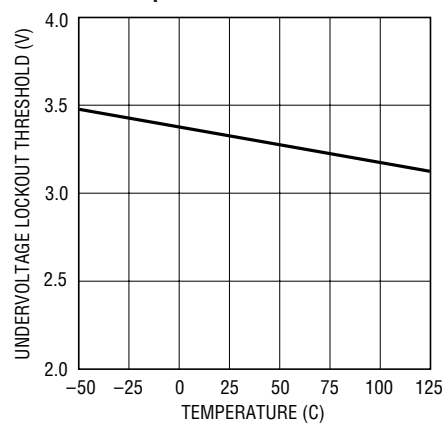

3713 G27

PIN FUNCTIONS

RUN/SS (Pin 1): Run Control and Soft-Start Input. A capacitor to ground at this pin sets the ramp time to full output current (approximately $3s/\mu\text{F}$) and the time delay for overcurrent latchoff (see Applications Information). Forcing this pin below 0.8V shuts down the device.

V_{ON} (Pin 2): On-Time Voltage Input. Voltage trip point for the on-time comparator. Tying this pin to the output voltage makes the on-time proportional to V_{OUT}. The comparator input defaults to 0.7V when the pin is grounded, 2.4V when the pin is tied to INTV_{CC}.

PGOOD (Pin 3): Power Good Output. Open-drain logic output that is pulled to ground when the output voltage is not within $\pm 7.5\%$ of the regulation point.

V_{RNG} (Pin 4): Sense Voltage Range Input. The voltage at this pin is ten times the nominal sense voltage at maximum output current and can be set from 0.5V to 2V by a resistive divider from INTV_{CC}. The nominal sense voltage defaults to 70mV when this pin is tied to ground, 140mV when tied to INTV_{CC}.

FCB (Pin 5): Forced Continuous Input. Tie this pin to ground to force continuous synchronous operation at low load, to INTV_{CC} to enable discontinuous mode operation at low load or to a resistive divider from a secondary output when using a secondary winding.

I_{TH} (Pin 6): Current Control Threshold and Error Amplifier Compensation Point. The current comparator threshold increases with this control voltage. The voltage ranges from 0V to 2.4V with 0.8V corresponding to zero sense voltage (zero current).

SGND (Pins 7, 11): Signal Ground. All small-signal components and compensation components should connect to this ground, which in turn connects to PGND at one point.

I_{ON} (Pin 8): On-Time Current Input. Tie a resistor from V_{IN} to this pin to set the one-shot timer current and thereby set the switching frequency.

V_{FB1} (Pin 9): Error Amplifier Feedback Input. This pin connects the error amplifier input to an external resistive divider from V_{OUT}.

SHDN (Pin 10): Shutdown, Active Low. Tie to 1V or more to enable boost converter portion of the LTC3713. Ground to shut down.

V_{FB2} (Pin 12): Boost Converter Feedback. The V_{FB2} pin is connected to INTV_{CC} through a resistor divider to set the voltage on INTV_{CC}. Set INTV_{CC} voltage according to:

$$V_{\text{INTVCC}} = 1.23\text{V}(1 + R_{\text{F4}}/R_{\text{F3}})$$

SW2 (Pin 13): Boost Converter Switch Pin. Connect inductor/diode for boost converter portion here. Minimize trace area at this pin to keep EMI down.

PGND (Pins 14, 19): Power Ground. Connect these pins closely to the source of the bottom N-channel MOSFET, the (–) terminal of C_{VCC} and the (–) terminal of C_{IN}.

V_{IN2} (Pin 15): Input Supply Pin for Boost Converter Portion of LTC3713. Must be locally bypassed.

V_{IN1} (Pin 16): Main Input Supply. Decouple this pin to PGND with an RC filter (1Ω, 0.1μF).

INTV_{CC} (Pin 17): Internal Regulator Output. The driver and control circuits are powered from this voltage. Decouple this pin to power ground with a minimum of 4.7μF low ESR tantalum or ceramic capacitor.

BG (Pin 18): Bottom Gate Drive. Drives the gate of the bottom N-channel MOSFET between ground and INTV_{CC}.

SENSE[–] (Pin 20): Negative Current Sense Comparator Input. The (–) input to the current comparator is normally connected to power ground unless using a resistive divider from INTV_{CC} (see Applications Information).

SENSE⁺ (Pin 21): Positive Current Sense Comparator Input. The (+) input to the current comparator is normally connected to the SW1 node unless using a sense resistor (see Applications Information).

SW1 (Pin 22): Switch Node. The (–) terminal of the bootstrap capacitor C_B connects here. This pin swings from a diode voltage drop below ground up to V_{IN}.

TG (Pin 23): Top Gate Drive. Drives the top N-channel MOSFET with a voltage swing equal to INTV_{CC} superimposed on the switch node voltage SW1.

BOOST (Pin 24): Boosted Floating Driver Supply. The (+) terminal of the bootstrap capacitor C_B connects here. This pin swings from a diode voltage drop below INTV_{CC} up to V_{IN} + INTV_{CC}.

FUNCTIONAL DIAGRAMS

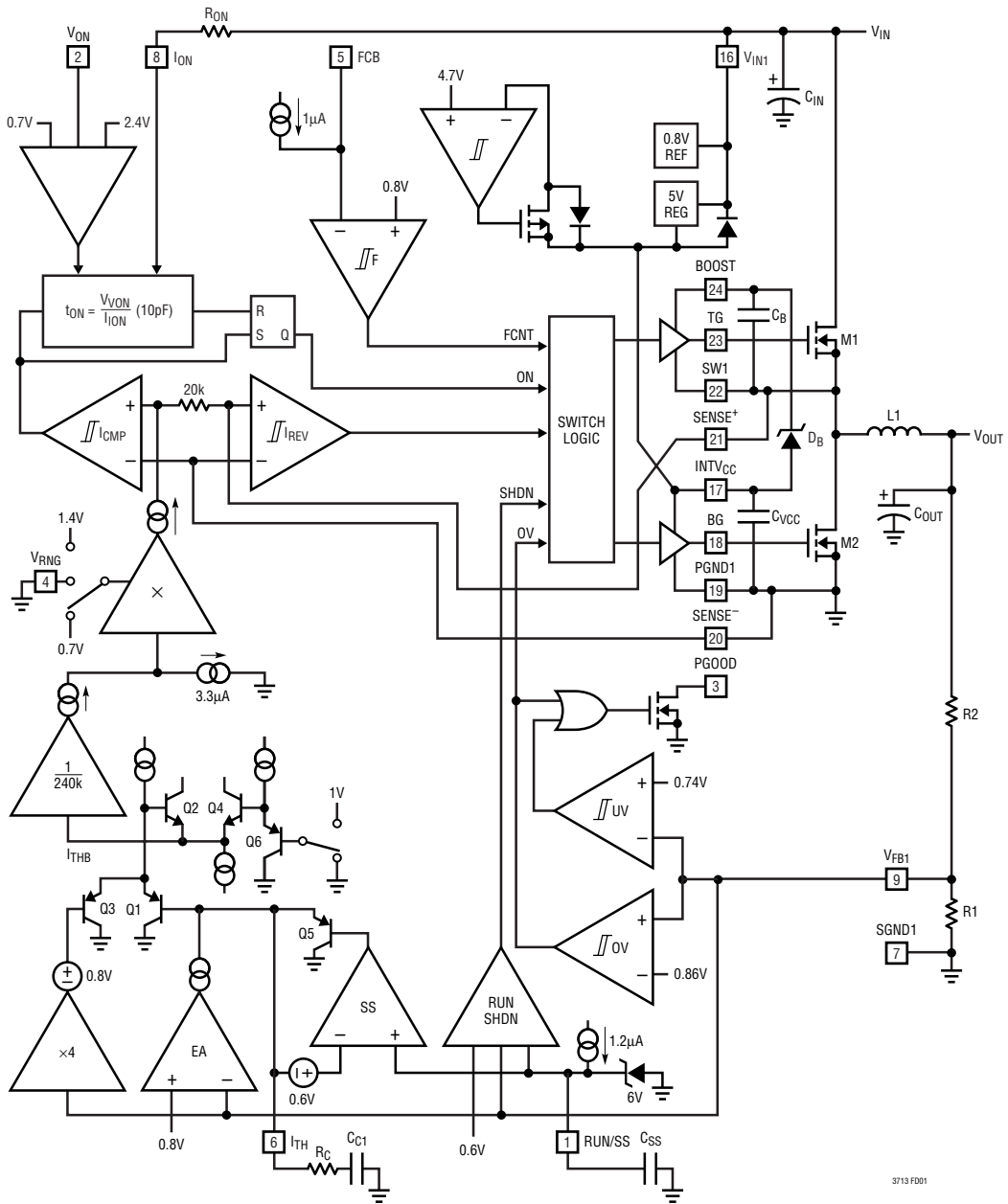

3713 FD01

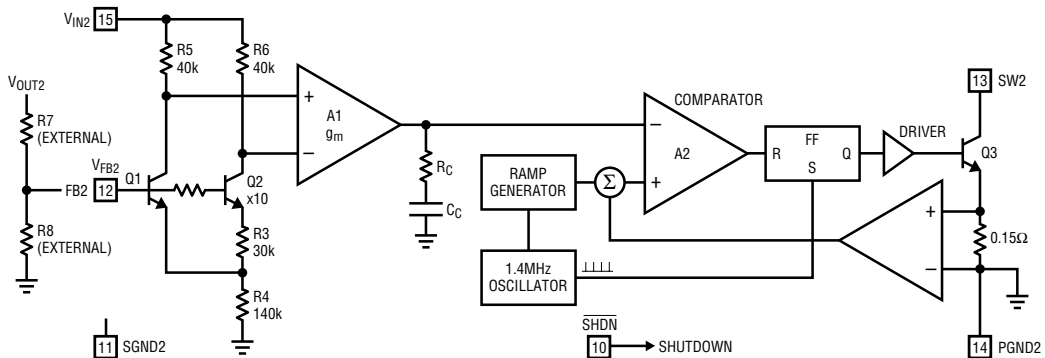

3713 FD02

OPERATION

Main Control Loop

The LTC3713 is a current mode controller for DC/DC step-down converters designed to operate from low input voltages. It incorporates a boost converter with a buck regulator.

Buck Regulator Operation

In normal operation, the top MOSFET is turned on for a fixed interval determined by a one-shot timer OST. When the top MOSFET is turned off, the bottom MOSFET is turned on until the current comparator I_{CMP} trips, restarting the one-shot timer and initiating the next cycle. Inductor current is determined by sensing the voltage between the SENSE⁺ and SENSE⁻ pins using the bottom MOSFET on-resistance. The voltage on the I_{TH} pin sets the comparator threshold corresponding to inductor valley current. The error amplifier EA adjusts this voltage by comparing the feedback signal V_{FB1} from the output voltage with an internal 0.8V reference. If the load current increases, it causes a drop in the feedback voltage relative to the reference. The I_{TH} voltage then rises until the average inductor current again matches the load current.

At low load currents, the inductor current can drop to zero and become negative. This is detected by current reversal comparator I_{REV} which then shuts off M2, resulting in discontinuous operation. Both switches will remain off with the output capacitor supplying the load current until the I_{TH} voltage rises above the zero current level (0.8V) to initiate another cycle. Discontinuous mode operation is disabled by comparator F when the FCB pin is brought below 0.8V, forcing continuous synchronous operation.

The operating frequency is determined implicitly by the top MOSFET on-time and the duty cycle required to maintain regulation. The one-shot timer generates an on-time that is proportional to the ideal duty cycle, thus holding frequency approximately constant with changes in V_{IN} . The nominal frequency can be adjusted with an external resistor R_{ON} .

Overvoltage and undervoltage comparators OV and UV pull the PGOOD output low if the output feedback voltage exits a $\pm 7.5\%$ window around the regulation point. Furthermore, in an overvoltage condition, M1 is turned off

and M2 is turned on and held on until the overvoltage condition clears.

Foldback current limiting is provided if the output is shorted to ground. As V_{FB1} drops, the buffered current threshold voltage I_{THB} is pulled down by clamp Q3 to a 1V level set by Q4 and Q6. This reduces the inductor valley current level to one sixth of its maximum value as V_{FB1} approaches 0V.

Pulling the RUN/SS pin low forces the controller into its shutdown state, turning off both M1 and M2. Releasing the pin allows an internal 1.2 μ A current source to charge up an external soft-start capacitor C_{SS} . When this voltage reaches 1.5V, the controller turns on and begins switching, but with the I_{TH} voltage clamped at approximately 0.6V below the RUN/SS voltage. As C_{SS} continues to charge, the soft-start current limit is removed.

INTV_{CC} Power

Power for the top and bottom MOSFET drivers and most of the internal controller circuitry is derived from the INTV_{CC} pin. The top MOSFET driver is powered from a floating bootstrap capacitor C_B . This capacitor is recharged from INTV_{CC} through an external Schottky diode D_B when the top MOSFET is turned off.

Boost Regulator Operation

The 5V power source for INTV_{CC} can be provided by a current mode, internally compensated fixed frequency step-up switching regulator that has been incorporated into the LTC3713.

Operation can be best understood by referring to the Functional Diagrams. Q1 and Q2 form a bandgap reference core whose loop is closed around the output of the regulator. The voltage drop across R5 and R6 is low enough such that Q1 and Q2 do not saturate, even when V_{IN2} is 1V. When there is no load, V_{FB2} rises slightly above 1.23V, causing V_C (the error amplifier's output) to decrease. Comparator A2's output stays high, keeping switch Q3 in the off state. As increased output loading causes the V_{FB2} voltage to decrease, A1's output increases. Switch current is regulated directly on a cycle-by-cycle basis by the V_C node. The flip-flop is set at the beginning of each

OPERATION

switch cycle, turning on the switch. When the summation of a signal representing switch current and a ramp generator (introduced to avoid subharmonic oscillations at duty factors greater than 50%) exceeds the V_C signal, comparator A2 changes state, resetting the flip-flop and turning off the switch. More power is delivered to the output as switch current is increased. The output voltage, attenuated by external resistor divider R7 and R8, appears at the V_{FB2} pin, closing the overall loop. Frequency compensation is provided internally by R_C and C_C . Transient

response can be optimized by the addition of a phase lead capacitor C_{PL} in parallel with R7 in applications where large value or low ESR output capacitors are used.

As the load current is decreased, the switch turns on for a shorter period each cycle. If the load current is further decreased, the boost converter will skip cycles to maintain output voltage regulation. If the V_{FB2} pin voltage is increased significantly above 1.23V, the boost converter will enter a low power state.

APPLICATIONS INFORMATION

A typical LTC3713 application circuit is shown in Figure 1. External component selection is primarily determined by the maximum load current and begins with the selection of the sense resistance and power MOSFET switches. The LTC3713 uses the on-resistance of the synchronous power MOSFET for determining the inductor current. The desired amount of ripple current and operating frequency largely determines the inductor value. Finally, C_{IN} is selected for its ability to handle the large RMS current into the converter and C_{OUT} is chosen with low enough ESR to meet the output voltage ripple and transient specification.

Maximum Sense Voltage and V_{RNG} Pin

Inductor current is determined by measuring the voltage across a sense resistance that appears between the SENSE+ and SENSE- pins. The maximum sense voltage is set by the voltage applied to the V_{RNG} pin and is equal to approximately $(0.133)V_{RNG}$. The current mode control loop will not allow the inductor current valleys to exceed $(0.133)V_{RNG}/R_{SENSE}$. In practice, one should allow some margin for variations in the LTC3713 and external component values and a good guide for selecting the sense resistance is:

$$R_{SENSE} = \frac{V_{RNG}}{10 \cdot I_{OUT(MAX)}}$$

An external resistive divider from $INTV_{CC}$ can be used to set the voltage of the V_{RNG} pin between 0.5V and 2V

resulting in nominal sense voltages of 50mV to 200mV. Additionally, the V_{RNG} pin can be tied to SGND or $INTV_{CC}$ in which case the nominal sense voltage defaults to 70mV or 140mV, respectively. The maximum allowed sense voltage is about 1.33 times this nominal value.

Connecting the SENSE+ and SENSE- Pins

The LTC3713 can be used with or without a sense resistor. When using a sense resistor, it is placed between the source of the bottom MOSFET M2 and ground. Connect the SENSE+ and SENSE- pins as a Kelvin connection to the sense resistor with SENSE+ at the source of the bottom MOSFET and the SENSE- pin to PGND1. Using a sense resistor provides a well defined current limit, but adds cost and reduces efficiency. Alternatively, one can eliminate the sense resistor and use the bottom MOSFET as the current sense element by simply connecting the SENSE+ pin to the drain and the SENSE- pin to the source of the bottom MOSFET. This improves efficiency, but one must carefully choose the MOSFET on-resistance as discussed in a later section.

Applications Requiring Symmetric Current Limit

The I_{TH} voltage has a range of 0V to 2.4V with 0.8V corresponding to 0A. In applications in which the output will only be sourcing current, this allows the output to sink one third of the maximum source current. For applications in which the output will be sourcing and sinking current, it might be desirable to have a symmetrical output current

APPLICATIONS INFORMATION

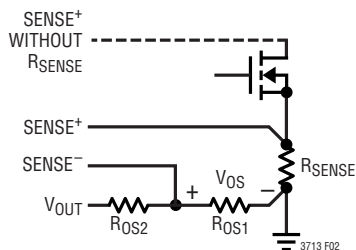

Figure 2. Sense Voltage Offset

range with respect to zero current. This can be accomplished by introducing an offset into the sense voltage as shown in Figure 2.

The first step in calculating the amount of required offset voltage is to determine the maximum sense voltage.

$$V_{\text{SENSE}} = I_{\text{OUT(MAX)}} \cdot R_{\text{SENSE}}$$

A good rule of thumb is to set the maximum sense voltage for a current limit that is 30% greater than the maximum source current.

The voltage on pin V_{RNG} should be set based on the value of V_{SENSE} .

$$V_{\text{RNG}} = V_{\text{SENSE}}/0.133$$

V_{OS} can be calculated using the following formula:

$$V_{\text{OS}} = 0.6V_{\text{SENSE}}$$

The offset voltage is added as shown in Figure 2 and can be set by choosing the values of R_{OS1} and R_{OS2} :

$$V_{\text{OS}} = \frac{V_{\text{OUT}} \cdot R_{\text{OS1}}}{R_{\text{OS1}} + R_{\text{OS2}}}$$

The offset voltage must be scaled to V_{OUT} to avoid interfering with the internal current limit foldback.

Power MOSFET Selection

The LTC3713 requires two external N-channel power MOSFETs, one for the top (main) switch and one for the bottom (synchronous) switch. Important parameters for the power MOSFETs are the breakdown voltage $V_{(\text{BR})\text{DSS}}$, threshold voltage $V_{(\text{GS})\text{TH}}$, on-resistance $R_{\text{DS(ON)}}$, reverse transfer capacitance C_{RSS} and maximum current $I_{\text{DS(MAX)}}$.

The gate drive voltage is set by the 5V INTV_{CC} supply. Consequently, logic-level threshold MOSFETs must be used in LTC3713 applications.

When the bottom MOSFET is used as the current sense element, particular attention must be paid to its on-resistance. MOSFET on-resistance is typically specified with a maximum value $R_{\text{DS(ON)(MAX)}}$ at 25°C. In this case, additional margin is required to accommodate the rise in MOSFET on-resistance with temperature:

$$R_{\text{DS(ON)(MAX)}} = \frac{R_{\text{SENSE}}}{\rho_T}$$

The ρ_T term is a normalization factor (unity at 25°C) accounting for the significant variation in on-resistance with temperature, typically about 0.4%/°C as shown in Figure 3. For a maximum junction temperature of 100°C, using a value $\rho_T = 1.3$ is reasonable.

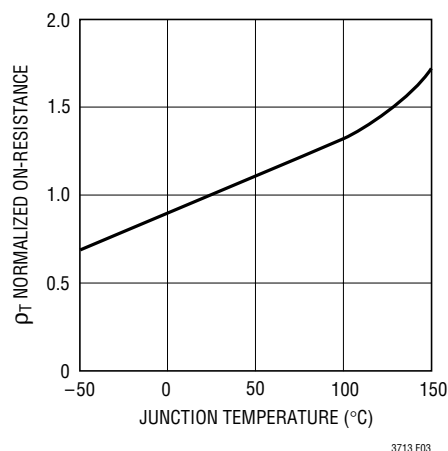

Figure 3. $R_{\text{DS(ON)}}$ vs Temperature

The power dissipated by the top and bottom MOSFETs strongly depends upon their respective duty cycles and the load current. When the LTC3713 is operating in continuous mode, the duty cycles for the MOSFETs are:

$$D_{\text{TOP}} = \frac{V_{\text{OUT}}}{V_{\text{IN}}}$$

$$D_{\text{BOT}} = \frac{V_{\text{IN}} - V_{\text{OUT}}}{V_{\text{IN}}}$$

APPLICATIONS INFORMATION

The resulting power dissipation in the MOSFETs at maximum output current are:

$$P_{TOP} = D_{TOP} I_{OUT(MAX)}^2 \rho_{T(TOP)} R_{DS(ON)(MAX)} + k V_{IN}^2 I_{OUT(MAX)} C_{RSS} f$$

$$P_{BOT} = D_{BOT} I_{OUT(MAX)}^2 \rho_{T(BOT)} R_{DS(ON)(MAX)}$$

Both MOSFETs have I^2R losses and the top MOSFET includes an additional term for transition losses, which are largest at high input voltages. The constant $k = 1.7A^{-1}$ can be used to estimate the amount of transition loss. The bottom MOSFET losses are greatest when the bottom duty cycle is near 100%, during a short-circuit or at high input voltage.

Operating Frequency

The choice of operating frequency is a tradeoff between efficiency and component size. Low frequency operation improves efficiency by reducing MOSFET switching losses but requires larger inductance and/or capacitance in order to maintain low output ripple voltage.

The operating frequency of LTC3713 applications is determined implicitly by the one-shot timer that controls the on-time t_{ON} of the top MOSFET switch. The on-time is set by the current into the I_{ON} pin and the voltage at the V_{ON} pin according to:

$$t_{ON} = \frac{V_{VON}}{I_{ON}} (10pF)$$

Tying a resistor R_{ON} from V_{IN} to the I_{ON} pin yields an on-time inversely proportional to V_{IN} . For a step-down converter, this results in approximately constant frequency operation as the input supply varies:

$$f = \frac{V_{OUT}}{V_{VON} R_{ON} (10pF)} \text{ [Hz]}$$

To hold frequency constant during output voltage changes, tie the V_{ON} pin to V_{OUT} . The V_{ON} pin has internal clamps that limit its input to the one-shot timer. If the pin is tied below 0.7V, the input to the one-shot is clamped at 0.7V. Similarly, if the pin is tied above 2.4V, the input is clamped at 2.4V.

Because the voltage at the I_{ON} pin is about 0.7V, the current into this pin is not exactly inversely proportional to V_{IN} , especially in applications with lower input voltages. To account for the 0.7V drop on the I_{ON} pin, the following equation can be used to calculate the frequency:

$$f = \frac{(V_{IN} - 0.7V)V_{OUT}}{V_{VON} \cdot V_{IN} \cdot R_{ON} (10pF)}$$

To correct for this error, an additional resistor R_{ON2} connected from the I_{ON} pin to the 5V $INTV_{CC}$ supply will further stabilize the frequency.

$$R_{ON2} = \frac{5V}{0.7V} R_{ON}$$

Changes in the load current magnitude will also cause frequency shift. Parasitic resistance in the MOSFET switches and inductor reduce the effective voltage across the inductance, resulting in increased duty cycle as the load current increases. By lengthening the on-time slightly as current increases, constant frequency operation can be maintained. This is accomplished with a resistive divider from the I_{TH} pin to the V_{ON} pin and V_{OUT} . The values required will depend on the parasitic resistances in the

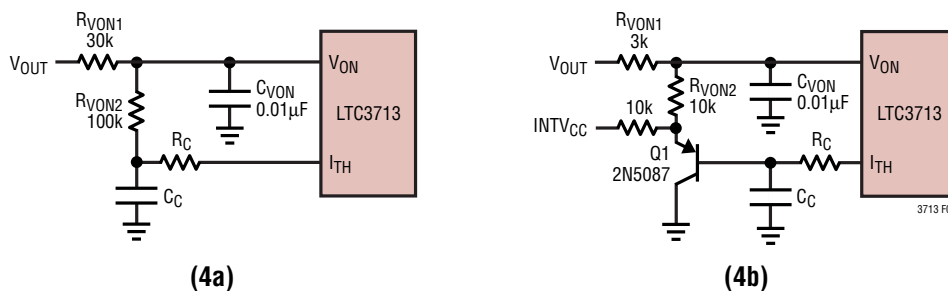

Figure 4. Adjusting Frequency Shift with Load Current Changes

APPLICATIONS INFORMATION

specific application. A good starting point is to feed about 25% of the voltage change at the I_{TH} pin to the V_{ON} pin as shown in Figure 4a. Place capacitance on the V_{ON} pin to filter out the I_{TH} variations at the switching frequency. The resistor load on I_{TH} reduces the DC gain of the error amp and degrades load regulation, which can be avoided by using the PNP emitter follower of Figure 4b.

Inductor L1 Selection

Given the desired input and output voltages, the inductor value and operating frequency determine the ripple current:

$$\Delta I_L = \left(\frac{V_{OUT}}{fL} \right) \left(1 - \frac{V_{OUT}}{V_{IN}} \right)$$

Lower ripple current reduces core losses in the inductor, ESR losses in the output capacitors and output voltage ripple. Highest efficiency operation is obtained at low frequency with small ripple current. However, achieving this requires a large inductor. There is a tradeoff between component size, efficiency and operating frequency.

A reasonable starting point is to choose a ripple current that is about 40% of $I_{OUT(MAX)}$. The largest ripple current occurs at the highest V_{IN} . To guarantee that ripple current does not exceed a specified maximum, the inductance should be chosen according to:

$$L = \left(\frac{V_{OUT}}{f \Delta I_L(MAX)} \right) \left(1 - \frac{V_{OUT}}{V_{IN(MAX)}} \right)$$

Once the value for L is known, the type of inductor must be selected. High efficiency converters generally cannot afford the core loss found in low cost powdered iron cores, forcing the use of more expensive ferrite, molypermalloy or Kool M μ [®] cores. A variety of inductors designed for high current, low voltage applications are available from manufacturers such as Sumida, Panasonic, Coiltronics, Coilcraft and Toko.

Schottky Diode D1 Selection

The Schottky diode D1 shown in Figure 1 conducts during the dead time between the conduction of the power MOSFET switches. It is intended to prevent the body diode

of the bottom MOSFET from turning on and storing charge during the dead time, which can cause a modest (about 1%) efficiency loss. The diode can be rated for about one half to one fifth of the full load current since it is on for only a fraction of the duty cycle. In order for the diode to be effective, the inductance between it and the bottom MOSFET must be as small as possible, mandating that these components be placed adjacently. The diode can be omitted if the efficiency loss is tolerable.

C_{IN} and C_{OUT} Selection

The input capacitance C_{IN} is required to filter the square wave current at the drain of the top MOSFET. Use a low ESR capacitor sized to handle the maximum RMS current.

$$I_{RMS} \cong I_{OUT(MAX)} \frac{V_{OUT}}{V_{IN}} \sqrt{\frac{V_{IN}}{V_{OUT}} - 1}$$

This formula has a maximum at $V_{IN} = 2V_{OUT}$, where $I_{RMS} = I_{OUT(MAX)}/2$. This simple worst-case condition is commonly used for design because even significant deviations do not offer much relief. Note that ripple current ratings from capacitor manufacturers are often based on only 2000 hours of life which makes it advisable to derate the capacitor.

The selection of C_{OUT} is primarily determined by the ESR required to minimize voltage ripple and load step transients. The output ripple ΔV_{OUT} is approximately bounded by:

$$\Delta V_{OUT} \leq \Delta I_L \left(ESR + \frac{1}{8fC_{OUT}} \right)$$

Since ΔI_L increases with input voltage, the output ripple is highest at maximum input voltage. Typically, once the ESR requirement is satisfied, the capacitance is adequate for filtering and has the necessary RMS current rating.

Multiple capacitors placed in parallel may be needed to meet the ESR and RMS current handling requirements. Dry tantalum, special polymer, aluminum electrolytic and ceramic capacitors are all available in surface mount packages. Special polymer capacitors offer very low ESR but have lower capacitance density than other types.

Kool M μ is a registered trademark of Magnetics, Inc.

APPLICATIONS INFORMATION

Tantalum capacitors have the highest capacitance density but it is important to only use types that have been surge tested for use in switching power supplies. Aluminum electrolytic capacitors have significantly higher ESR, but can be used in cost-sensitive applications providing that consideration is given to ripple current ratings and long term reliability. Ceramic capacitors have excellent low ESR characteristics but can have a high voltage coefficient and audible piezoelectric effects. The high Q of ceramic capacitors with trace inductance can also lead to significant ringing. When used as input capacitors, care must be taken to ensure that ringing from inrush currents and switching does not pose an overvoltage hazard to the power switches and controller. To dampen input voltage transients, add a small 5 μ F to 50 μ F aluminum electrolytic capacitor with an ESR in the range of 0.5 Ω to 2 Ω . High performance through-hole capacitors may also be used, but an additional ceramic capacitor in parallel is recommended to reduce the effect of their lead inductance.

Top MOSFET Driver Supply (C_B , D_B)

An external bootstrap capacitor C_B connected to the BOOST pin supplies the gate drive voltage for the topside MOSFET. This capacitor is charged through diode D_B from INTV_{CC} when the switch node is low. When the top MOSFET turns on, the switch node rises to V_{IN} and the BOOST pin rises to approximately $V_{IN} + \text{INTV}_{CC}$. The boost capacitor needs to store about 100 times the gate charge required by the top MOSFET. In most applications a 0.1 μ F to 0.47 μ F X5R or X7R dielectric capacitor is adequate.

Discontinuous Mode Operation and FCB Pin

The FCB pin determines whether the bottom MOSFET remains on when current reverses in the inductor. Tying this pin above its 0.8V threshold enables discontinuous operation where the bottom MOSFET turns off when inductor current reverses. The load current at which current reverses and discontinuous operation begins depends on the amplitude of the inductor ripple current and will vary with changes in V_{IN} . Tying the FCB pin below the 0.8V threshold forces continuous synchronous operation, allowing current to reverse at light loads and maintaining high frequency operation.

Fault Conditions: Current Limit and Foldback

The maximum inductor current is inherently limited in a current mode controller by the maximum sense voltage. In the LTC3713, the maximum sense voltage is controlled by the voltage on the V_{RNG} pin. With valley current control, the maximum sense voltage and the sense resistance determine the maximum allowed inductor valley current. The corresponding output current limit is:

$$I_{LIMIT} = \frac{V_{SNS(MAX)}}{R_{DS(ON)PT}} + \frac{1}{2} \Delta I_L$$

The current limit value should be checked to ensure that $I_{LIMIT(MIN)} > I_{OUT(MAX)}$. The minimum value of current limit generally occurs with the largest V_{IN} at the highest ambient temperature, conditions that cause the largest power loss in the converter. Note that it is important to check for self-consistency between the assumed MOSFET junction temperature and the resulting value of I_{LIMIT} which heats the MOSFET switches.

Caution should be used when setting the current limit based upon the $R_{DS(ON)}$ of the MOSFETs. The maximum current limit is determined by the minimum MOSFET on-resistance. Data sheets typically specify nominal and maximum values for $R_{DS(ON)}$, but not a minimum. A reasonable assumption is that the minimum $R_{DS(ON)}$ lies the same amount below the typical value as the maximum lies above it. Consult the MOSFET manufacturer for further guidelines.

To further limit current in the event of a short circuit to ground, the LTC3713 includes foldback current limiting. If the output falls by more than 25%, then the maximum sense voltage is progressively lowered to about one sixth of its full value.

Minimum Off-time and Dropout Operation

The minimum off-time $t_{OFF(MIN)}$ is the smallest amount of time that the LTC3713 is capable of turning on the bottom MOSFET, tripping the current comparator and turning the MOSFET back off. This time is generally about 250ns. The minimum off-time limit imposes a maximum duty cycle of $t_{ON}/(t_{ON} + t_{OFF(MIN)})$. If the maximum duty cycle is reached,

APPLICATIONS INFORMATION

due to a dropping input voltage for example, then the output will drop out of regulation. The minimum input voltage to avoid dropout is:

$$V_{IN(MIN)} = V_{OUT} \frac{t_{ON} + t_{OFF(MIN)}}{t_{ON}}$$

Output Voltage Programming

A resistor divider connected between V_{FB1} and V_{OUT} sets the output voltage according to the following equation:

$$V_{OUT} = 0.8V \left(1 + \frac{R_{F2}}{R_{F1}} \right)$$

External Gate Drive Buffers

The LTC3713 drivers are adequate for driving up to about 30nC into MOSFET switches with RMS currents of 50mA. Applications with larger MOSFET switches or operating at frequencies requiring greater RMS currents will benefit from using external gate drive buffers such as the LTC1693. Alternately, the external buffer circuit shown in Figure 5 can be used. Note that the bipolar devices reduce the signal swing at the MOSFET gate.

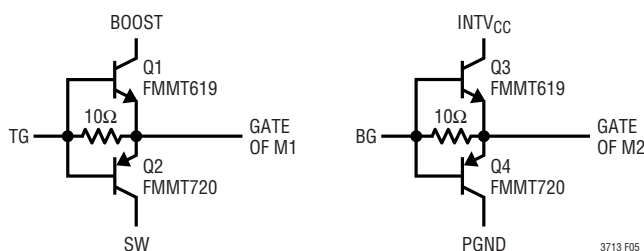

Figure 5. Optional External Gate Driver

Soft-Start and Latchoff with the RUN/SS Pin

The RUN/SS pin provides a means to shut down the LTC3713 as well as a timer for soft-start and overcurrent latchoff. Pulling the RUN/SS pin below 0.8V puts the LTC3713 into a low quiescent current shutdown ($I_Q < 30\mu A$). Releasing the pin allows an internal 1.2μA current source to charge up the external timing capacitor C_{SS} . If RUN/SS has been pulled all the way to ground, there is a delay before starting of about:

$$t_{DELAY} = \frac{1.5V}{1.2\mu A} C_{SS} = (1.3s/\mu F) C_{SS}$$

When the voltage on RUN/SS reaches 1.5V, the LTC3713 begins operating with a clamp on I_{TH} of approximately 0.9V. As the RUN/SS voltage rises to 3V, the clamp on I_{TH} is raised until its full 2.4V range is available. This takes an additional 1.3s/μF, during which the maximum load current is reduced. During start-up the maximum load current is reduced until either the RUN/SS pin rises to 3V or the output reaches 75% of its final value. The pin can be driven from logic as shown in Figure 6. Diode D1 reduces the start delay while allowing C_{SS} to charge up slowly for the soft-start function.

After the controller has been started and given adequate time to charge up the output capacitor, C_{SS} is used as a short-circuit timer. After the RUN/SS pin charges above 4V, if the output voltage falls below 75% of its regulated value, then a short-circuit fault is assumed. A 1.8μA current then begins discharging C_{SS} . If the fault condition persists until the RUN/SS pin drops to 3.5V, then the controller turns off both power MOSFETs, shutting down the converter permanently. The RUN/SS pin must be actively pulled down to ground in order to restart operation.

The overcurrent protection timer requires that the soft-start timing capacitor C_{SS} be made large enough to guarantee that the output is in regulation by the time C_{SS} has reached the 4V threshold. In general, this will depend upon the size of the output capacitance, output voltage and load current characteristic. A minimum soft-start capacitor can

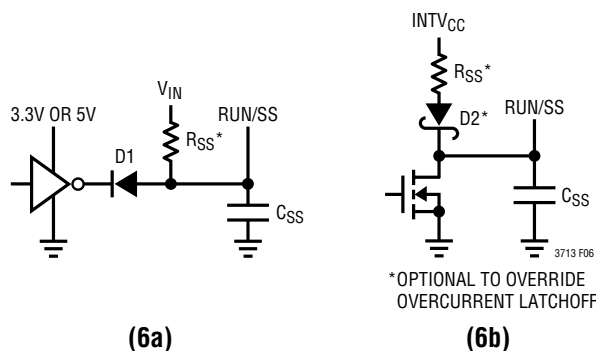

Figure 6. RUN/SS Pin Interfacing with Latchoff Defeated

APPLICATIONS INFORMATION

be estimated from:

$$C_{SS} > C_{OUT} \cdot V_{OUT} \cdot R_{SENSE} (10^{-4} [F/V \cdot s])$$

Generally 0.1 μ F is more than sufficient.

Overcurrent latching operation is not always needed or desired. Load current is already limited during a short-circuit by the current foldback circuitry and latching operation can prove annoying during troubleshooting. The feature can be overridden by adding a pull-up current greater than 5 μ A to the RUN/SS pin. The additional current prevents the discharge of C_{SS} during a fault and also shortens the soft-start period. Using a resistor to V_{IN} as shown in Figure 6a is simple, but slightly increases shutdown current. Connecting a resistor to $INTV_{CC}$ as shown in Figure 6b eliminates the additional shutdown current, but requires a diode to isolate C_{SS} . Any pull-up network must be able to pull RUN/SS above the 4.2V maximum threshold of the latching circuit and overcome the 4 μ A maximum discharge current.

INTV_{CC} Supply

The 5V supply that powers the drivers and internal circuitry within the LTC3713 can be supplied by either an internal P-channel low dropout regulator if V_{IN} is greater than 5V or the internal boost regulator if V_{IN} is less than 5V. The $INTV_{CC}$ pin can supply up to 50mA RMS and must be bypassed to ground with a minimum of 4.7 μ F tantalum or other low ESR capacitor. Good bypassing is necessary to supply the high transient currents required by the MOSFET gate drivers. Applications using large MOSFETs with a high input voltage and high frequency of operation may cause the LTC3713 to exceed its maximum junction temperature rating or RMS current rating. In continuous mode operation, this current is $I_{GATECHG} = f(Q_{g(TOP)} + Q_{g(BOT)})$. The junction temperature can be estimated from the equations given in Note 2 of the Electrical Characteristics.

Inductor Selection for Boost Converter

For the boost converter, the inductance should be 4.7 μ H for input voltages less than 3.3V and 10 μ H for inputs above 3.3V. The inductor should have a saturation current rating of approximately 0.5A or greater. A guide for selecting an inductor for the boost converter is to choose a ripple current that is 40% of the current supplied by the boost

converter. To ensure that the ripple current doesn't exceed a specified amount, the inductance can be chosen according to the following equation:

$$L = \frac{V_{IN2(MIN)} \left(1 - \frac{V_{IN2(MAX)}}{V_{OUT(BOOST)}} \right)}{\Delta I \cdot f}$$

Diode D3 Selection

A Schottky diode is recommended for use in the boost converter section. The Motorola MBR0520 is a very good choice.

Boost Converter Output Capacitor

Because the LTC3713's boost converter is internally compensated, loop stability must be carefully considered when choosing its output capacitor. Small, low cost tantalum capacitors have some ESR, which aids stability. However, ceramic capacitors are becoming more popular, having attractive characteristics such as near-zero ESR, small size and reasonable cost. Simply replacing a tantalum output capacitor with a ceramic unit will decrease the phase margin, in some cases to unacceptable levels. With the addition of a phase-lead capacitor and isolating resistor, the boost converter portion of the LTC3713 can be used successfully with ceramic output capacitors.

Efficiency Considerations

The percent efficiency of a switching regulator is equal to the output power divided by the input power times 100%. It is often useful to analyze individual losses to determine what is limiting the efficiency and which change would produce the most improvement. Although all dissipative elements in the circuit produce losses, four main sources account for most of the losses in LTC3713 circuits:

1. DC I^2R losses. These arise from the resistances of the MOSFETs, inductor and PC board traces and cause the efficiency to drop at high output currents. In continuous mode the average output current flows through L, but is chopped between the top and bottom MOSFETs. If the two MOSFETs have approximately the same $R_{DS(ON)}$, then the resistance of one MOSFET can simply be summed with the resistances of L and the board traces to obtain the DC I^2R

APPLICATIONS INFORMATION

loss. For example, if $R_{DS(ON)} = 0.01\Omega$ and $R_L = 0.005\Omega$, the loss will range from 1% up to 10% as the output current varies from 1A to 10A for a 1.5V output.

2. Transition loss. This loss arises from the brief amount of time the top MOSFET spends in the saturated region during switch node transitions. It depends upon the input voltage, load current, driver strength and MOSFET capacitance, among other factors. The loss is significant at input voltages above 20V and can be estimated from:

$$\text{Transition Loss} \cong (1.7A^{-1}) V_{IN}^2 I_{OUT} C_{RSS} f$$

3. $INTV_{CC}$ current. This is the sum of the MOSFET driver and control currents.

4. C_{IN} loss. The input capacitor has the difficult job of filtering the large RMS input current to the regulator. It must have a very low ESR to minimize the AC I^2R loss and sufficient capacitance to prevent the RMS current from causing additional upstream losses in fuses or batteries.

Other losses, including C_{OUT} ESR loss, Schottky diode D1 conduction loss during dead time and inductor core loss generally account for less than 2% additional loss.

When making adjustments to improve efficiency, the input current is the best indicator of changes in efficiency. If you make a change and the input current decreases, then the efficiency has increased. If there is no change in input current, then there is no change in efficiency.

Checking Transient Response

The regulator loop response can be checked by looking at the load transient response. Switching regulators take several cycles to respond to a step in load current. When a load step occurs, V_{OUT} immediately shifts by an amount equal to ΔI_{LOAD} (ESR), where ESR is the effective series resistance of C_{OUT} . ΔI_{LOAD} also begins to charge or discharge C_{OUT} generating a feedback error signal used by the regulator to return V_{OUT} to its steady-state value. During this recovery time, V_{OUT} can be monitored for overshoot or ringing that would indicate a stability problem. The I_{TH} pin external components shown in Figure 1 will provide adequate compensation for most applications. For a detailed explanation of switching control loop theory see Application Note 76.

Design Example

As a design example, take a supply with the following specifications: $V_{IN} = 1.8V$ to $3.3V$, $V_{OUT} = 1.25V \pm 100mV$, $I_{OUT(MAX)} = 6A$, $f = 300kHz$. First, calculate the timing resistor with $V_{ON} = V_{OUT}$:

$$R_{ON} = \frac{(2.5V - 0.7V)}{(2.5V)(300kHz)(10pF)} = 240k$$

Next, use a standard value of 237k and choose the inductor for about 40% ripple current at the maximum V_{IN} :

$$L = \frac{1.25V}{(300kHz)(0.4)(6A)} \left(1 - \frac{1.25V}{3.3V} \right) = 1.08\mu H$$

Selecting a standard value of $1\mu H$ results in a maximum ripple current of:

$$\Delta I_L = \frac{1.25V}{(300kHz)(1\mu H)} \left(1 - \frac{1.25V}{3.3V} \right) = 2.6A$$

Next, choose the synchronous MOSFET switch. Choosing an IRF7811A ($R_{DS(ON)} = 0.013\Omega$, $C_{RSS} = 60pF$, $\theta_{JA} = 50^\circ C/W$) yields a nominal sense voltage of:

$$V_{SNS(NOM)} = (6A)(1.3)(0.013\Omega) = 101.4mV$$

Tying V_{RNG} to 1V will set the current sense voltage range for a nominal value of 100mV with current limit occurring at 133mV. To check if the current limit is acceptable, assume a junction temperature of about $10^\circ C$ above a $50^\circ C$ ambient with $\rho_{60^\circ C} = 1.15$:

$$I_{LIMIT} \geq \frac{133mV}{(1.15)(0.013\Omega)} + \frac{1}{2}(2.6A) = 10.2A$$

and double check the assumed T_J in the MOSFET:

$$P_{BOT} = \frac{3.3V - 1.25V}{3.3V} \left(\frac{10.2A}{2} \right)^2 (1.15)(0.013\Omega) \\ = 0.24W$$

$$T_J = 50^\circ C + (0.24W)(50^\circ C/W) = 62^\circ C$$

Now check the power dissipation of the top MOSFET at current limit with $\rho_{80^\circ C} = 1.3$:

APPLICATIONS INFORMATION

$$P_{TOP} = \frac{1.25V}{3.3V} (10.2A)^2 (1.3) (0.013\Omega) + (1.7) (3.3V) (10.2A)^2 (60pF) (300kHz) = 0.68W$$

$$T_J = 50^\circ C + (0.68W)(50^\circ C/W) = 84^\circ C$$

C_{IN} is chosen for an RMS current rating of about 6A at temperature. The output capacitors are chosen for a low ESR of 0.005Ω to minimize output voltage changes due to inductor ripple current and load steps. The ripple voltage will be only:

$$\Delta V_{OUT(RIPPLE)} = \Delta I_{L(MAX)} (ESR) = (2.6A) (0.005\Omega) = 13mV$$

However, a 0A to 6A load step will cause an output change of up to:

$$\Delta V_{OUT(STEP)} = \Delta I_{LOAD} (ESR) = (6A) (0.005\Omega) = 30mV$$

The inductor for the boost converter is selected by first choosing an allowable ripple current. The boost converter will be operating in discontinuous mode. If we select a ripple current of 170mA for the boost converter, then:

$$L = \frac{3.3V \left(1 - \frac{3.3V}{5V} \right)}{(170mA)(1.4MHz)} = 4.7\mu H$$

The complete circuit is shown in Figure 7.

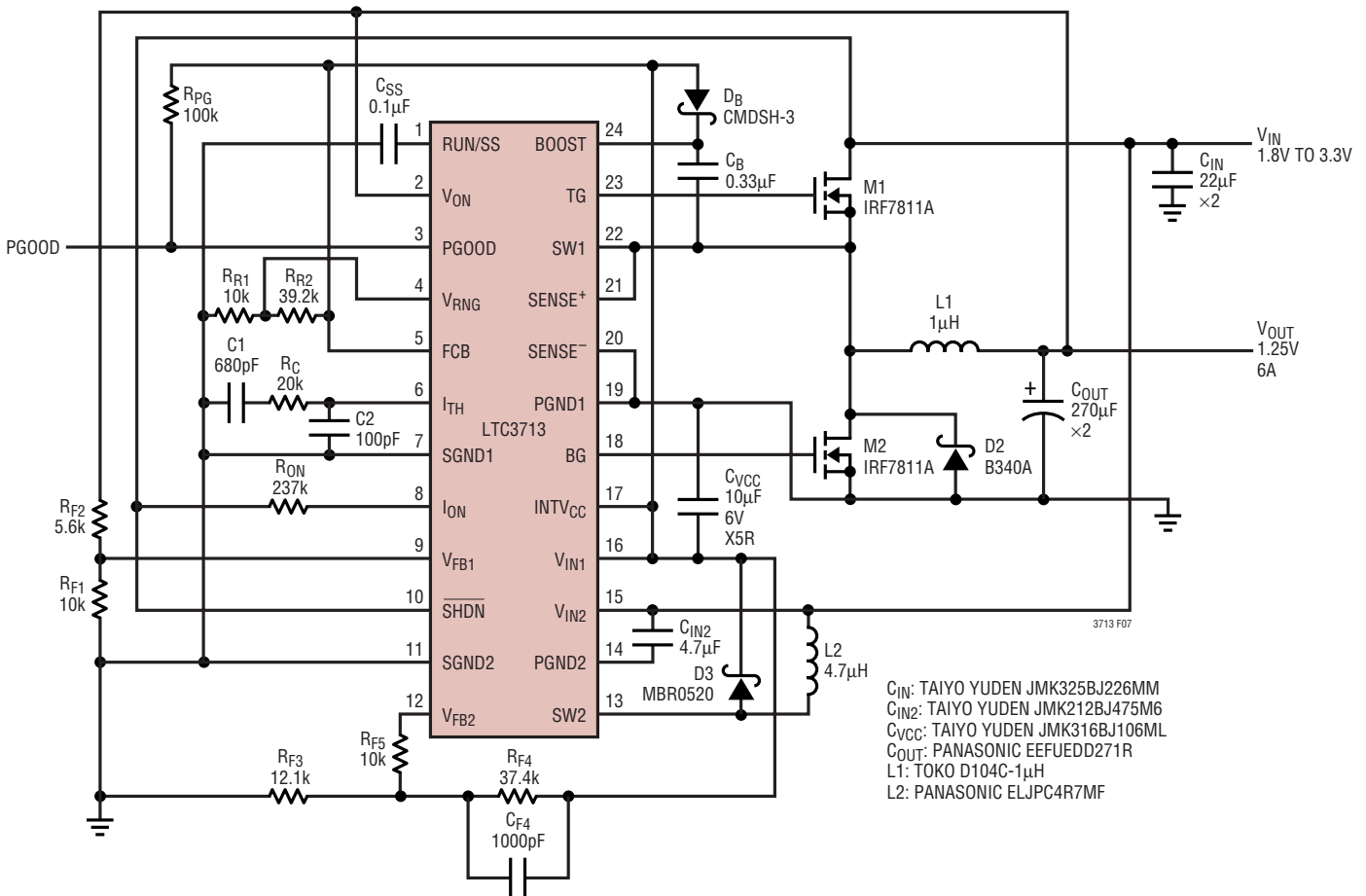

Figure 7. Design Example: 1.25V/6A at 300kHz from 1.8V to 3.3V

APPLICATIONS INFORMATION

PC Board Layout Checklist

When laying out a PC board follow one of the two suggested approaches. The simple PC board layout requires a dedicated ground plane layer. Also, for higher currents, it is recommended to use a multilayer board to help with heat sinking power components.

- The ground plane layer should not have any traces and it should be as close as possible to the layer with power MOSFETs.
- Place C_{IN} , C_{OUT} , MOSFETs, D1 and inductor all in one compact area. It may help to have some components on the bottom side of the board.
- Place LTC3713 chip with Pins 13 to 24 facing the power components. Keep the components connected to Pins 1 to 12 close to LTC3713 (noise sensitive components).
- Use an immediate via to connect the components to ground plane including SGND and PGND of LTC3713. Use several bigger vias for power components.
- Use a compact plane for switch node (SW) to improve cooling of the MOSFETs and to keep EMI down.
- Use planes for V_{IN} and V_{OUT} to maintain good voltage filtering and to keep power losses low.

- Flood all unused areas on all layers with copper. Flooding with copper will reduce the temperature rise of power component. You can connect the copper areas to any DC net (V_{IN} , V_{OUT} , GND or to any other DC rail in your system).

When laying out a printed circuit board, without a ground plane, use the following checklist to ensure proper operation of the controller. These items are also illustrated in Figure 8.

- Segregate the signal and power grounds. All small signal components should return to the SGND pin at one point which is then tied to the PGND pin close to the source of M2.
- Place M2 as close to the controller as possible, keeping the PGND, BG and SW traces short.
- Connect the input capacitor(s) C_{IN} close to the power MOSFETs. This capacitor carries the MOSFET AC current.
- Keep the high dV/dt SW, BOOST and TG nodes away from sensitive small-signal nodes.
- Connect the INTV_{CC} decoupling capacitor C_{VCC} closely to the INTV_{CC} and PGND pins.
- Connect the top driver boost capacitor C_B closely to the BOOST and SW pins.

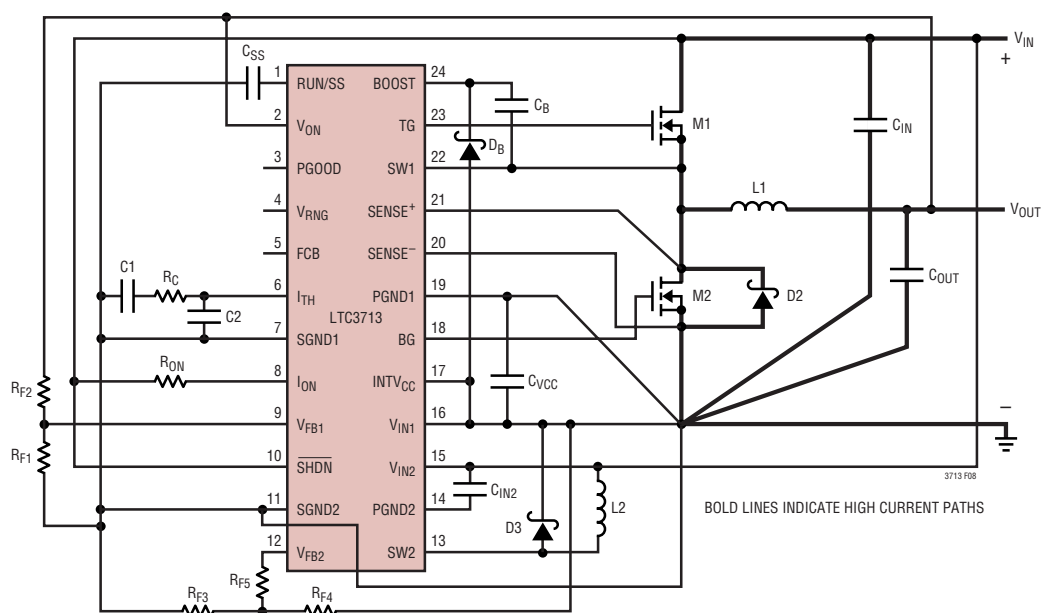
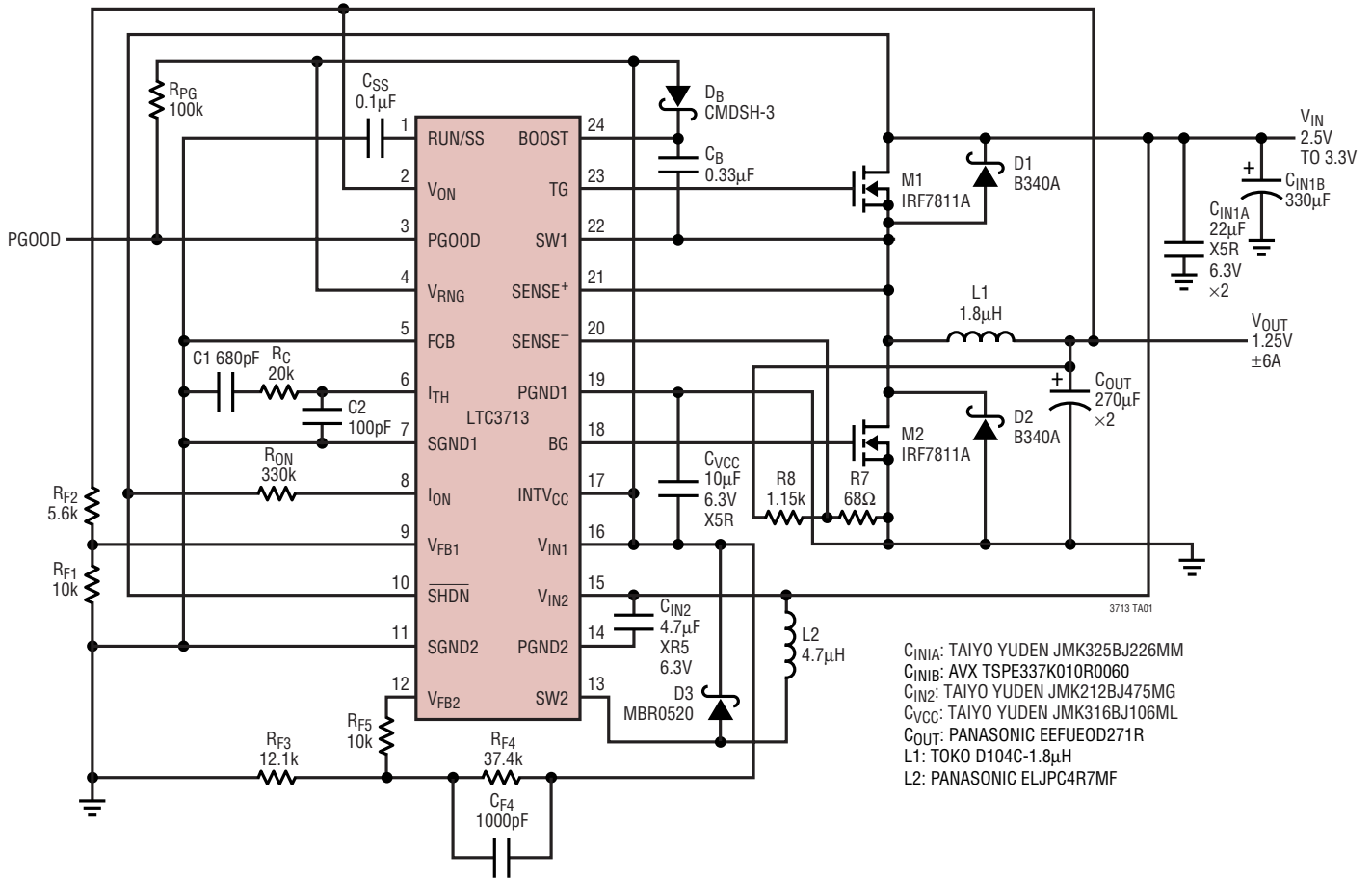

Figure 8. LTC3713 Layout Diagram

TYPICAL APPLICATIONS

1.25V/±6A Bus Terminator



TYPICAL APPLICATIONS

One-Half $V_{IN} \pm 6A$ Bus Terminator

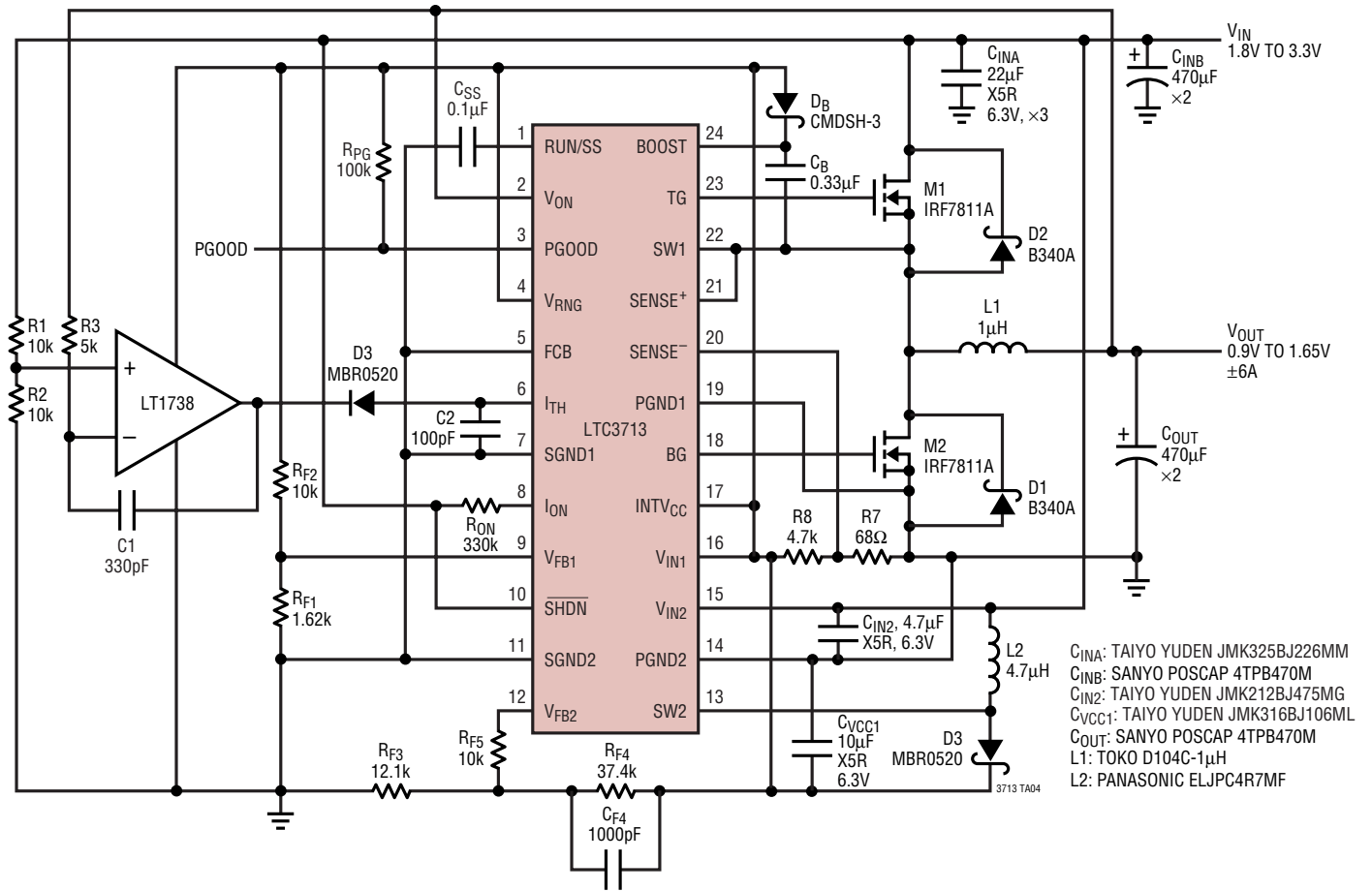

TYPICAL APPLICATIONS

Dual Output 1.25V/10A Buck Converter and 5V to 12V/130mA Boost Converter

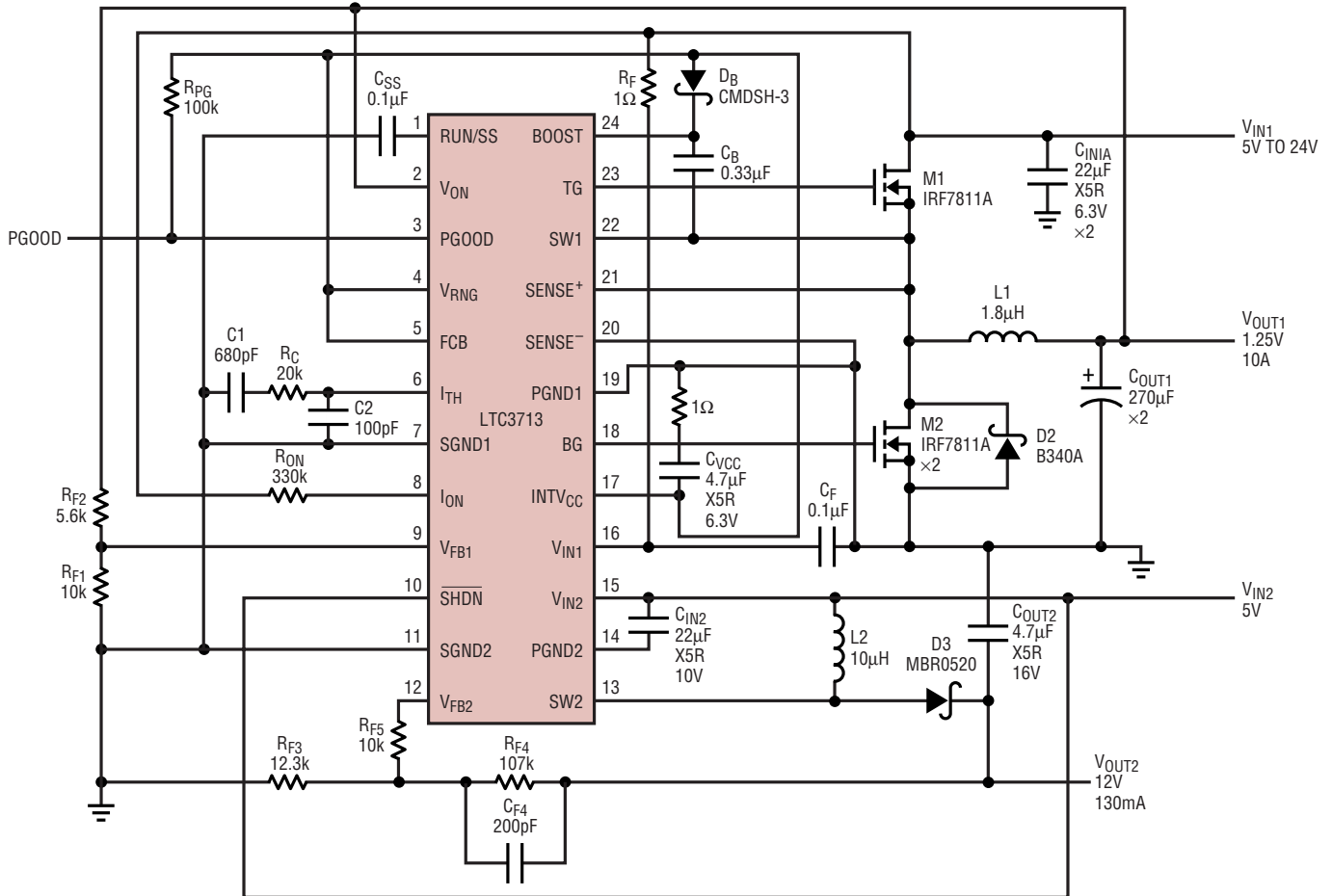

- CIN1A, CIN2: TAIYO YUDEN JMK325BJ226MM
- CINIB: AVX TSPE337K010R0060
- COUT1: PANASONIC EEFUEOD271R
- COUT2: TAIYO YUDEN EMK316BJ475ML
- CVCC: TAIYO YUDEN JMK212BJ475MG
- L1: TOKO D104C-1.8μH
- L2: PANASONIC ELJPC4R7MF

3713 TA02

PACKAGE DESCRIPTION

G Package
24-Lead Plastic SSOP (5.3mm)
 (Reference LTC DWG # 05-08-1640)

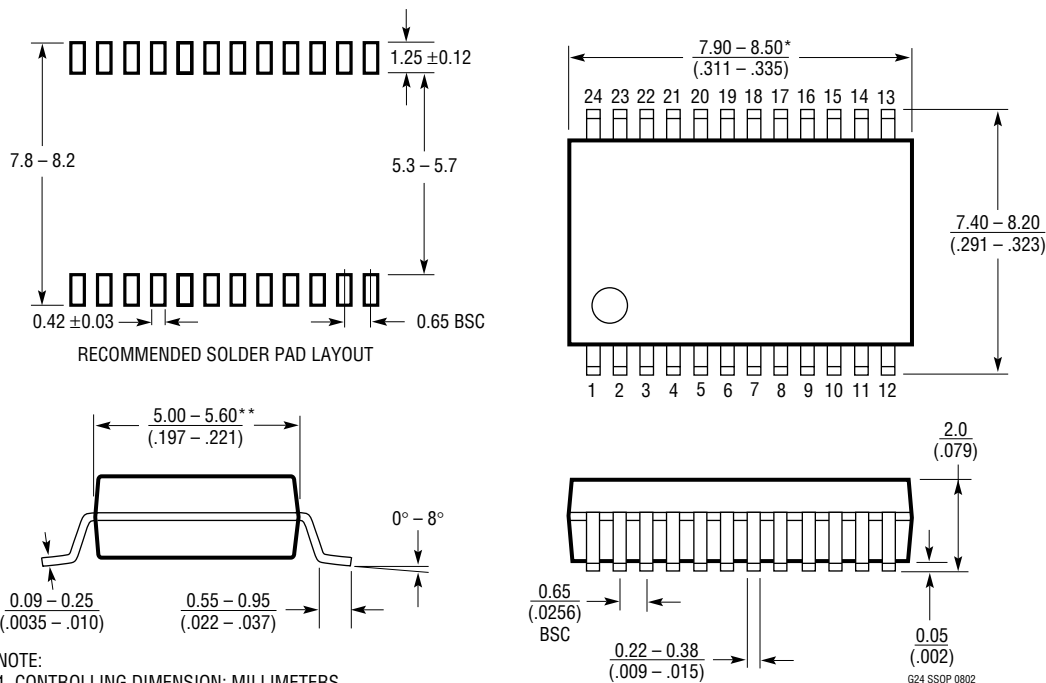

- NOTE:
1. CONTROLLING DIMENSION: MILLIMETERS
 2. DIMENSIONS ARE IN $\frac{\text{MILLIMETERS}}{\text{(INCHES)}}$
 3. DRAWING NOT TO SCALE
- *DIMENSIONS DO NOT INCLUDE MOLD FLASH. MOLD FLASH SHALL NOT EXCEED .152mm (.006") PER SIDE
- **DIMENSIONS DO NOT INCLUDE INTERLEAD FLASH. INTERLEAD FLASH SHALL NOT EXCEED .254mm (.010") PER SIDE

TYPICAL APPLICATION

3.3V to 5V Synchronous Boost Converter

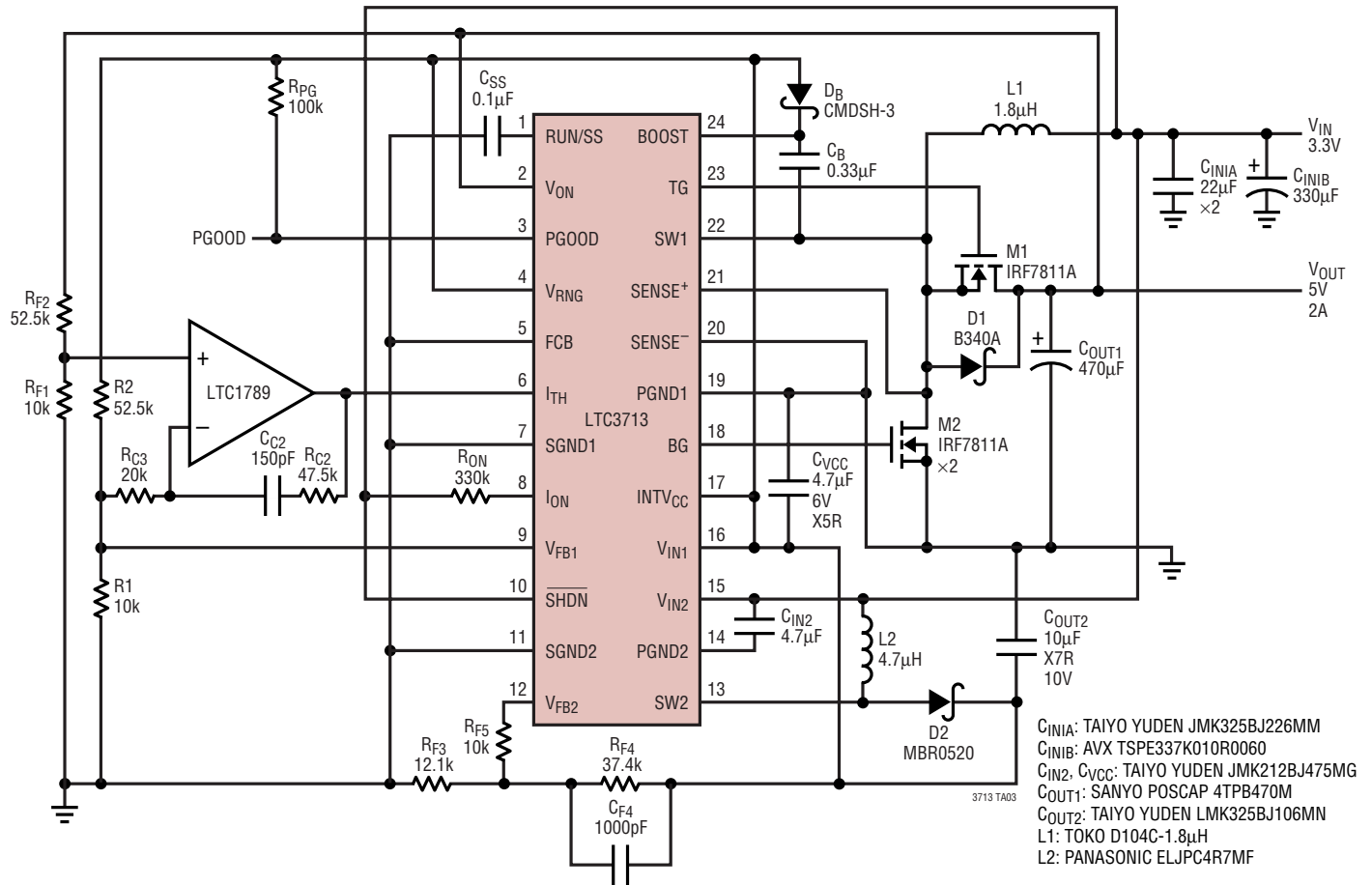

RELATED PARTS

PART NUMBER	DESCRIPTION	COMMENTS
LT [®] 1613	ThinSOT™ Step-Up DC/DC Converter	1.4MHz, 1.1V < V _{IN} < 10V
LTC1649	High Power Synchronous Step-Down Controller	3.3V Input, 1.265V ≤ V _{OUT} ≤ 2.xV, I _{OUT} Up to 20A
LTC1735	High Efficiency Synchronous Switching Regulator	4V ≤ V _{IN} ≤ 36V, 0.8V ≤ V _{OUT} ≤ 6V, SSOP-16
LTC1772	ThinSOT Current Mode Step-Down Controller	Small Solution, 2.5V ≤ V _{IN} ≤ 9.8V, 0.8V ≤ V _{OUT} ≤ V _{IN}
LTC1773	Synchronous Current Mode Step-Down Controller	2.65V ≤ V _{IN} ≤ 8.5V, 0.8V ≤ V _{OUT} ≤ V _{IN} , 550kHz Operation, >90% Efficiency
LTC1778	No R _{SENSE} Synchronous Step-Down Controller	No Sense Resistor Required, 4V ≤ V _{IN} ≤ 36V, 0.8V ≤ V _{OUT} ≤ V _{IN}
LTC1876	2-Phase, Dual Synchronous Step-Down Controller with Step-Up Regulator	2.6V ≤ V _{IN} ≤ 36V, Dual Output: 0.8V ≤ V _{OUT} ≤ (0.9)V _{IN}
LTC3711	5-Bit, Adjustable, No R _{SENSE} Synchronous Step-Down Controller	0.925V ≤ V _{OUT} ≤ 2V, 4V ≤ V _{IN} ≤ 36V
LTC3718	Low V _{IN} DDR Memory and SSTL Termination Power Supply	1.5V ≤ V _{IN} ≤ 3.3V, V _{OUT} = 1/2 V _{IN} , V _{OUT} Tracks V _{IN} 0.6V ≤ V _{OUT} (Termination Voltage)
LTC3778	No R _{SENSE} Synchronous Step-Down Controller	Optional Sense Resistor, 4V ≤ V _{IN} ≤ 36V, 0.6V ≤ V _{OUT} ≤ V _{IN}

ThinSOT is a trademark of Linear Technology Corporation.

3713fa