

LTC3589EUJ-1/LTC3589EUJ-2 8-Output Regulator with Sequencing and I²C

DESCRIPTION

Demonstration circuit 1808B-A/1808B-B is a multioutput power supply with a pushbutton controller and I²C, featuring the LTC[®]3589EUJ-1 (-A) or LTC3589EUJ-2 (-B). The LTC3589EUJ-x has three synchronous buck regulators, a buck-boost regulator, an always-on LDO and three LDO regulators. The input voltage range of the LTC3589EUJ-x is ideal for single-cell Li-Ion/Polymer battery applications.

The switching regulator settings, such as enables, feedback voltages, operating modes and other functions, can be controlled via I²C. All of the regulators, except the always-on LDO1, can also be enabled via external enable pins. After the first regulator is enabled, the remaining enable pins use a precision threshold to allow hardwired power-up sequences. All the regulators, except LDO1, can also be enabled via the I²C.

The LTC3589EUJ-x has two status registers, PGSTAT and IRQSTAT, that can be used to determine the current state of the device.

The two status registers, which can be read via I²C, indicate which regulators are in regulation and if a UV or OT event occurred. The command registers, which are used to control the switching regulators and program the special functions, can also be read back via I²C to assure the correct data was received.

Refer to the LTC3589EUJ data sheet for more details on the electrical and timing specifications and for an explanation of the different device options (LTC3589-1 and LTC3589-2). Also see Table 1 in this demo manual.

Design files for this circuit board are available at <http://www.linear.com/demo>

LT, LT, LTC, LTM, Linear Technology and the Linear Logo are registered trademarks and QuikEval is a trademark of Linear Technology Corporation. All other trademarks are the property of their respective owners.

PERFORMANCE SUMMARY Specifications are at T_A = 25°C

SYMBOL	PARAMETER	CONDITIONS	MIN	TYP	MAX	UNITS
V _{IN}	Input Voltage Range		2.7		5.5	V
V _{BUCK1}	Buck Regulator 1 Output Voltage	Buck 1 Enabled, I _{BUCK1} = 0 ~ 1.6A	0.62	1.206	1.38	V
V _{BUCK2}	Buck Regulator 2 Output Voltage	Buck 2 Enabled, I _{BUCK2} = 0 ~ 1.0A	0.937	1.819	2.08	V
V _{BUCK3}	Buck Regulator 3 Output Voltage	Buck 3 Enabled, I _{BUCK3} = 0 ~ 1.0A	0.648	1.259	1.44	V
V _{BUCK-BOOST}	Buck-Boost Regulator Output Voltage	Buck-Boost Enabled, I _{BUCK-BOOST} = 0 ~ 1.2A	3.17	3.30	3.43	V
V _{LDO1}	LDO1 Regulator Output Voltage	LDO1 Is Always On, I _{LDO1} = 0 ~ 25mA	1.13	1.20	1.27	V
V _{LDO2}	LDO2 Regulator Output Voltage	LDO2 Enabled, I _{LDO2} = 0 ~ 200mA	0.62	1.206	1.38	V
V _{LDO3}	LDO3 Regulator Output Voltage	LDO3 Enabled, I _{LDO3} = 0 ~ 200mA	1.756	1.80	1.854	V
V _{LDO4}	LDO4 Regulator Output Voltage	LDO4 Enabled, I _{LDO4} = 0 ~ 200mA	1.746	2.80	3.399	V

QUICK START PROCEDURE

1. Ensure that JP1 to JP3, and SW1 are in their default positions, as shown in Figure 1. Set PS1 to 5V and turn on. The RST0 LED should light until LDO1 comes on, and the PGOOD LED should come on and stay on

NOTE: The DV_{CC} voltage level may be selected on the DC590B. This is done by setting the V_{CCIO} jumper, JP6, on the DC590B board to one of the following settings: 3.3V, 5V, removed for 2.7V, or set to external if an external supply is used. Please set DV_{CC} to 5V.

2. Start the Linear Technology QuikEval™ program. This program should automatically detect the presence of the LTC3589EUJ-xdemo board (DC1808B-A/1808B-B) and activate the appropriate GUI, as seen in Figure 3. The GUI reads back the current voltages of the regulators. LDO1 should read 1.2V, and V_{IN} should read 5V; all others should be 0V.
3. Press the PB1 button on the DC1808B-A/1808B-B for more than 0.5s; all of the power supplies should come up and the displayed GUI page should match Figure 3. The sequencing for these supplies was set by Linear Technology, using resistor divider networks from the supply outputs to control the ENx lines.
4. Each of the supplies can be loaded to test the regulators, but be aware that LDO2~4 on the DC1558A are powered from V_{IN} , and the dissipation can be significant. If significant current is desired from these regulators, care with input voltage selection will be required.
5. Press and hold the PB1 button for more than 5s, and all of the regulators, except LDO1, will shut down. The GUI will show the voltages for all regulators, other than always-on LDO1, as 0V.
6. Refer to the Using the LTC3589EUJ Software section for more information on how to control the device using the LTC3589EUJ control window.
7. Refer to the LTC3589EUJ data sheet for more details on how the LTC3589EUJ operates.
8. When done, close the LTC3589EUJ GUI and turn off all loads and power supplies.

LTC3589, LTC3589-1, AND LTC3589-2 FUNCTIONAL COMPARISON

Table 1 summarizes the functional differences between the LTC3589, LTC3589-1, and LTC3589-2.

Table 1. LTC3589, LTC3589-1 and LTC3589-2 Functional Differences

	LTC3589	LTC3589-1	LTC3589-2
Power-On Inhibit Enable Delay	1 Second	<2ms	<2ms
Buck2 Current Output	1A	1.2A	1.2A
Buck3 Current Output	1A	1.2A	1.2A
PGOOD Fault Timeout	Enabled by Default. I ² C Disable.	Disabled by Default. I ² C Enable.	Disabled by Default. I ² C Enable.
PWR_ON to WAKE Delay	50ms	2ms	2ms
LDO3 V_{OUT}	1.8V	2.8V	2.8V
LDO4 V_{OUT} * Indicates Default V_{OUT}	1.8V, 2.5V, 2.8V*, 3.3V	1.2V*, 1.8V, 2.5V, 3.2V	1.2V*, 1.8V, 2.5V, 3.2V
Default LDO4 Enable	LDO34_EN Pin	I ² C	I ² C
Wait to Enable Until Output < 300mV	Yes, by Default. I ² C Select.	Yes, by Default. I ² C Select.	No, by Default. I ² C Select.
Insert 2k Discharge Resistor When Disabled	Yes, if Start-Up Is Wait to Enable Until Output < 300mV	Yes, if Start-Up Is Wait to Enable Until Output < 300mV	Always

QUICK START PROCEDURE

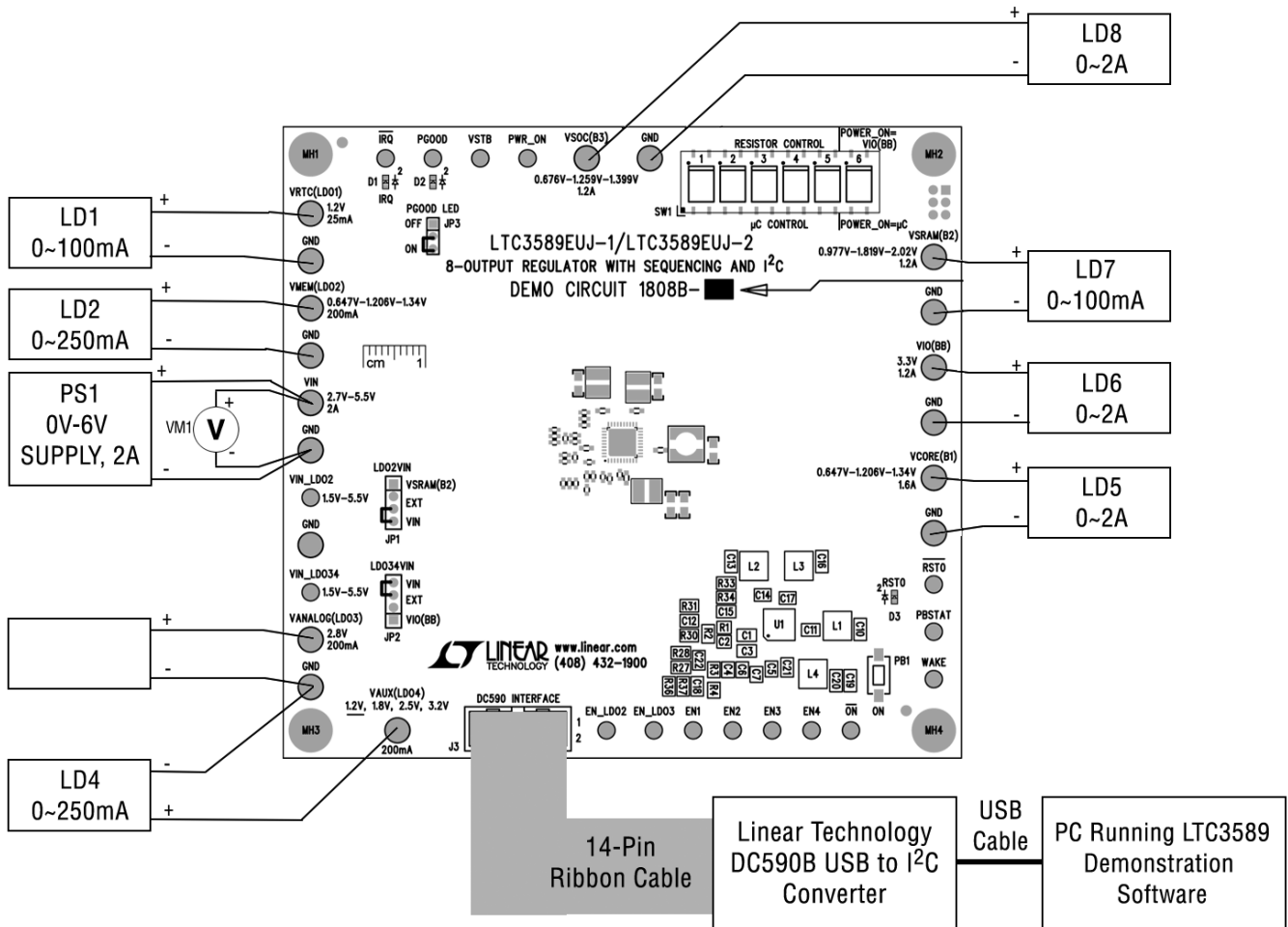

Note: All connections from equipment should be Kelvin connected directly to the board pins to which they are connected on this diagram. Any input or output leads should be twisted-pair.

Figure 1. Proper Measurement Equipment Setup

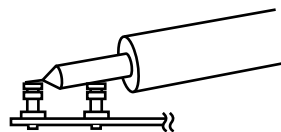

Figure 2. Measuring Input or Output Ripple

USING THE LTC3589EIJ SOFTWARE

Introduction

The LTC3589EIJ GUI provides control of most aspects of operation of the LTC3589EIJ. The LTC3589EIJ GUI also provides a means to manage the feedback divider resistors, turn the regulators on and off manually, and even to experiment with sequencing.

The LTC3589EIJ GUI is composed of four forms:

- The LTC3589-1 (DC1808B-A) or LTC3589-2 (DC1808B-B) form (Figure 3) is brought up by the QuikEval program.
- The Manage Resistors form (Figure 4) is brought up by pressing the Change Resistor Divider Networks button on the LTC3589 form.
- The Advanced Settings form (Figure 5) is brought up by pressing the Advanced Settings button on the LTC3589 form.
- The Sequencing form is brought up by pressing the Change LTC3589 Sequencing button.

The sequencing form, in turn, contains two tabs: Direct (Figure 6) and Table (Figure 7). These allow direct control and table based sequencing, respectively.

SW1, positions 1 to 5, sets the source of the ENx signals to the preselected resistor networks or to the on-board microcontroller. SW1, positions 1 to 5, should be set to Resistor Control for normal mode, and μ C Control for sequence modes (Direct and Table).

SW1, position 6, controls the source of PWR_ON. Resistor Control makes the source the buck-boost regulator output. μ C Control makes it controlled by the on-board microcontroller. This switch should be set to Resistor Control for normal mode and μ C Control for sequence modes.

View the LTC3589EIJ Product Page

This button opens your default Internet browser, and searches the Linear Technology Corporation website for information on the LTC3589EIJ when an Internet connection is available.

Buck1 ~ Buck3, Buck-Boost, and LDO2~LDO4 Sections

These sections control most aspects of the regulator operation. Some of the controls for the regulators are on the Advanced Settings form. Please consult the data sheet for operation of these bits.

In the Buck1~ Buck3 and LDO2 sections, there is a button labeled Go. Whenever the DAC sliders are changed or the regulator is switched between normal and standby, the appropriate control registers are changed. But, the LTC3589 will wait for the Go button to be pressed before going to the new voltage.

If the text box has a grey background, it cannot be directly edited. A good example of this is the command registers SCR1, OVEN, SCR2, etc., at the bottom of the LTC3589 form. These registers are changed by the various controls on the form.

The Auto Readback Enabled button determines if the IRQ-STAT and PGSTAT values are automatically read back. If automatic readback is disabled, the Readback button will do a one-time readback.

The Auto Update Enabled button determines if the command registers are automatically sent to the LTC3589 on change, and if the values of these registers are automatically read back. If automatic update is disabled, the Update All button will update all the command registers and read back the values.

For all the automatic update modes, an internal 100ms timer is used, so all values will be updated every 100ms, if enabled.

USING THE LTC3589EJ SOFTWARE

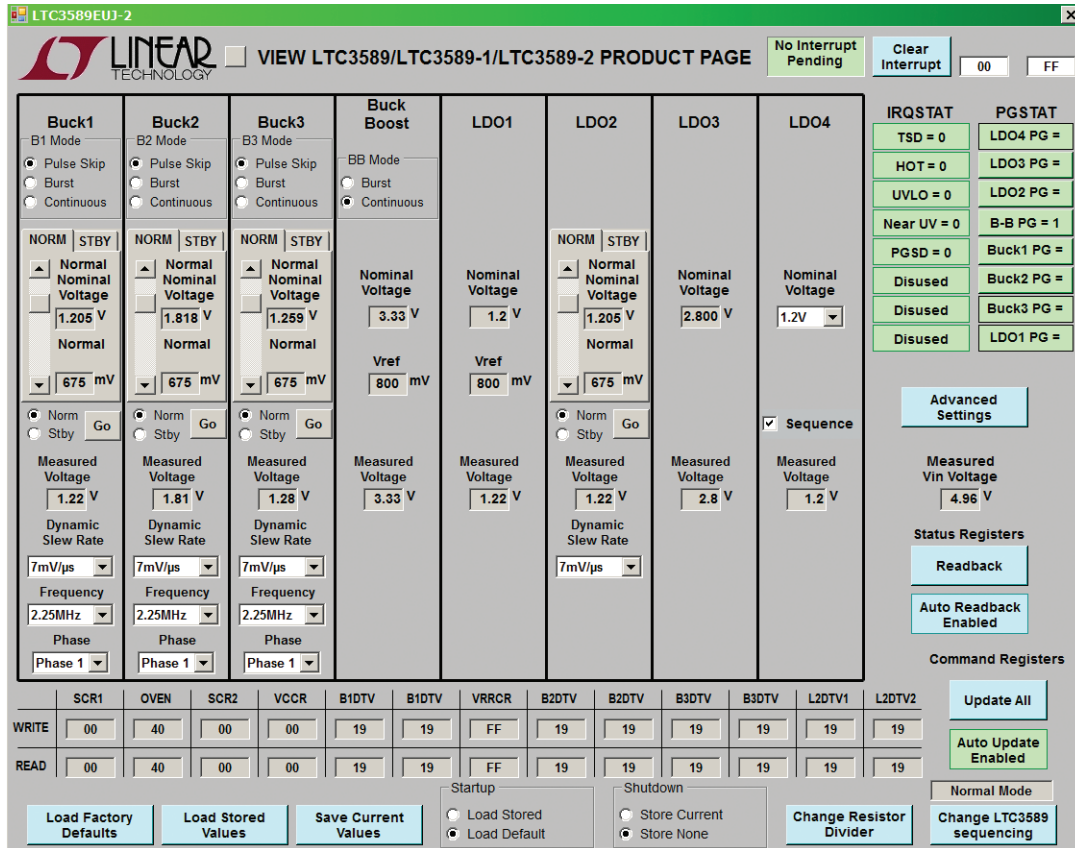

Figure 3. Main Form

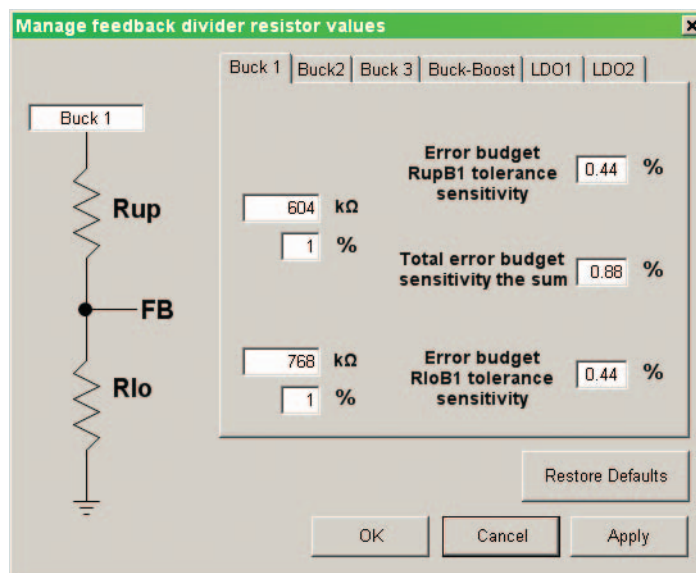

Figure 4. Manage Resistors Form

USING THE LTC3589EIJ SOFTWARE

Interrupts and Status

The current state of IRQSTAT and PGSTAT are displayed on the right. If an interrupt is pending, the IRQ LED (D1) on the DC1808B-A/1808B-B demo board will light. The interrupt box will change color to red, and indicate Interrupt Pending. To clear the interrupt, press the Clear Interrupt button.

Advanced Settings Button

This button brings up the Advanced Settings form (Figure 5), which allows the control of several less used bits. Any changes made in this form will immediately be reflected in the appropriate command registers on the LTC3589 form. However, if Auto Update Enabled is disabled, the value will not be sent to the LTC3589EIJ until auto update is re-enabled or Update All is pressed.

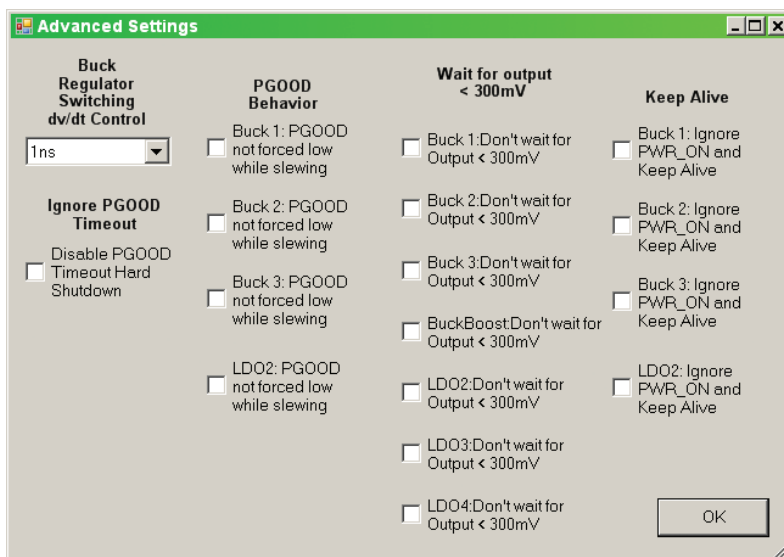

Figure 5. DC1808B-A (LTC3589EIJ-1) Advanced Settings Form

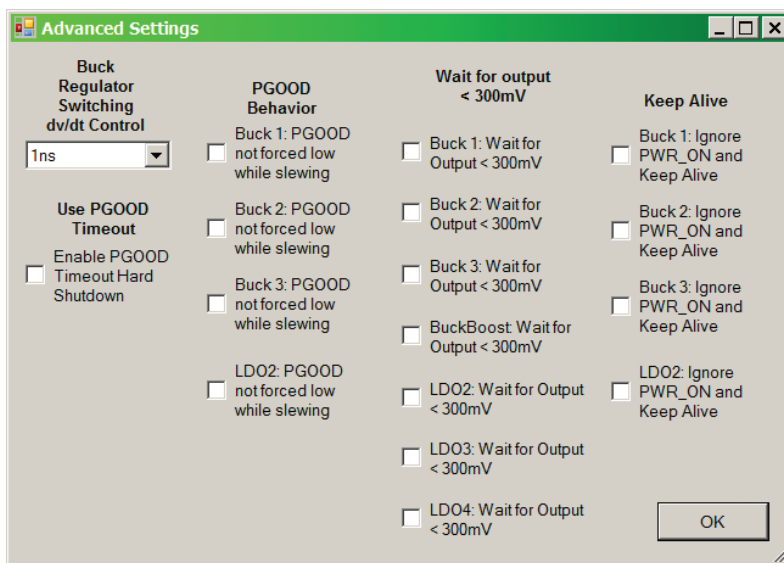

Figure 6. DC1808B-B (LTC3589EIJ-2) Advanced Settings Form

USING THE LTC3589EJ SOFTWARE

Mode Display

This box displays the current operating mode. The value of this box can be changed in the sequence form.

Load Factory Defaults

The factory default values for the command registers, regulator resistors and auto update states are immediately loaded.

Load Stored Values

The state of the command registers, regulator resistors and auto update states can be saved to a file and reused. This button causes the saved states to be loaded immediately.

Save Current Values

Immediately saves the state of the command registers, regulator resistors and auto update states to file.

Start-Up

The start-up section determines what the GUI will do at start-up, load default or stored command register, regulator resistors and auto update states.

Shutdown

The shutdown section determines what the GUI will do at shutdown, store the current command register, regulator resistor resistors and auto update values or not.

Change Resistor Divider Networks Button

This button brings up the Manage Feedback Divider Resistor Values form (Figure 4), which allows for different feedback divider resistor values. Any changes made in this form will immediately be reflected in the appropriate voltage value boxes on the LTC3589 form. It is the user's responsibility to ensure that the values in this form are the same as the values of the actual resistors on the demo board.



Figure 7. Sequence, Direct Form

USING THE LTC3589EJ SOFTWARE

Change LTC3589 Sequencing Button

This brings up the sequencing form which has two tabs Direct (Figure 6) and Table (Figure 7). These allow the direct control of the regulator on/off (Direct tab), or set up a sequence that will be downloaded to the on-board microcontroller to set the regulator sequencing (Table tab).

Both the direct and the table modes require that all positions of the SW1 dipswitch be in the μ C Control position.

Neither direct nor sequence mode can be enabled from the other mode. You must be in normal mode to enable direct or sequence mode.

Returning to normal mode explicitly, by using a button to disable direct or sequence modes, resets the regulator states to the default. However, if you return to normal mode by completing a downloaded sequence, the regulator states are not reset.

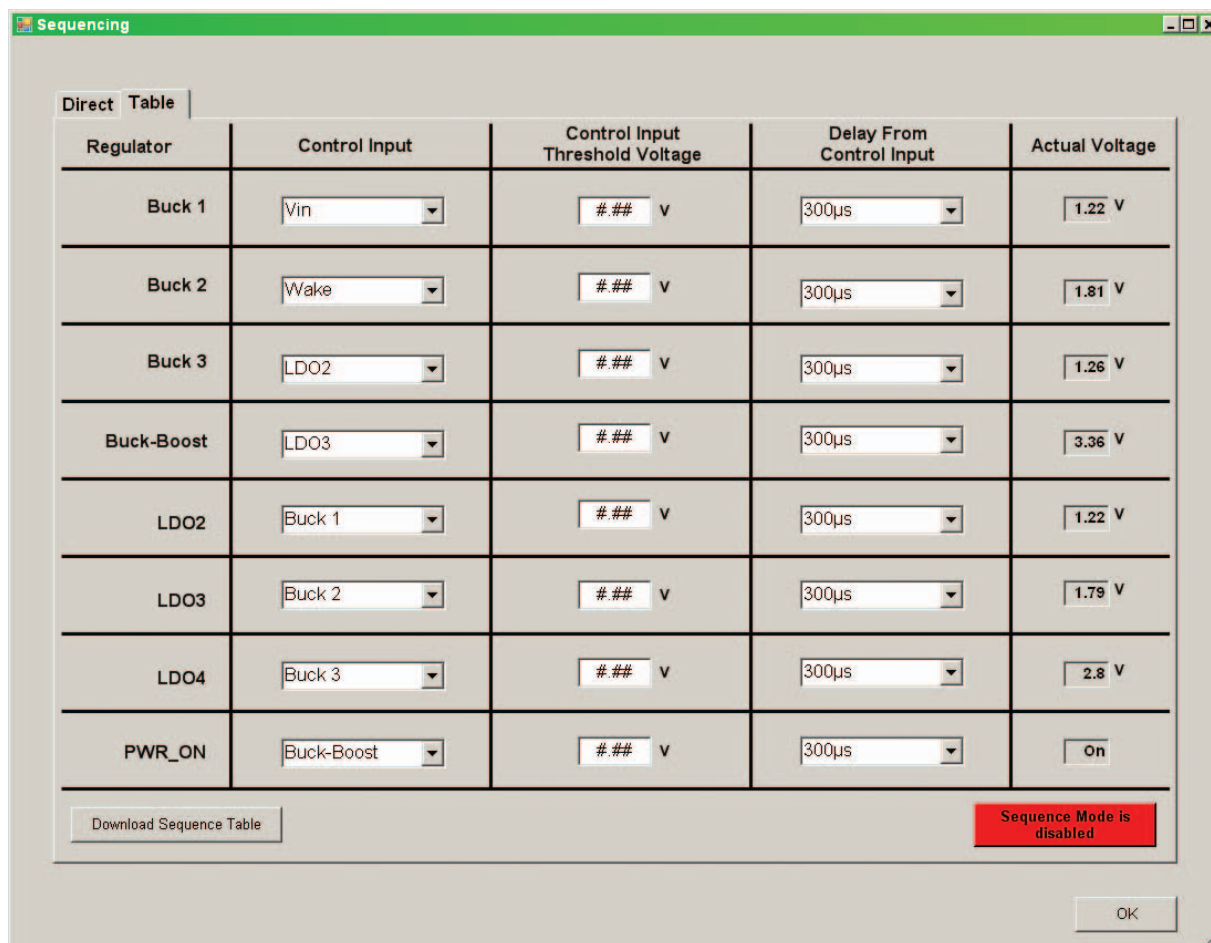

Figure 8. Sequence, Table Form

USING THE LTC3589EJ SOFTWARE

Direct

To directly control the on/off state of the regulators, choose the Direct tab, enable direct mode (the mode display on the LTC3589 form should change to direct). Ensure that the dipswitch positions are in the correct state and check the appropriate boxes. The regulators can now be turned on and off directly.

The Measured Voltage boxes are live and update on the 100ms update timer.

Table

To set up a sequence for the power supplies to power up, choose the Table tab. Do not enable sequence mode until a sequence table has been downloaded. Sequence tables can only be downloaded in normal mode.

Some error checking is done on the table before downloading, such as ensuring that at least one regulator is controlled by WAKE, but in general, the user must ensure that the sequence table is reasonable.

In particular, always ensure that one regulator is controlled by WAKE and that at least one regulator is used in the particular sequence controls PWR_ON. It is not necessary that you use all regulators, nor that only one regulator is

controlled at a time. For example, WAKE could start all regulators, or just one. If PWR_ON is not asserted in the sequence, the sequence will execute, but the regulators will shut down after 5s.

Once a sequence has been downloaded, and sequence mode has been set, press the PB1 button to start the sequence. In sequence mode it is not necessary press the PB1 button for 0.5s.

The level of the WAKE signal is the same as the level of the V_{IN} signal, that is, if V_{IN} is 3V, WAKE will assert at 3V. So, when choosing the threshold voltage for WAKE, make sure that you do not set it higher than the V_{IN} voltage. In fact, you should choose a voltage that is $\approx V_{IN}/2$.

When PWR_ON is asserted in the sequence, the on-board microcontroller determines that the sequence is done and sets the state to normal (without resetting the states of the regulators). The sequence / table form can now be closed. If you wish to rerun the sequence, hold down PB1 for more than 5s, until the regulators shut off. Go to the sequence / table form, and enable sequence mode. It is not necessary to download the sequence table again, as it is still in the on-board microcontroller's memory. Now, just press the PB1 button to restart the sequence.

DEMO MANUAL

DC1808B-A/DC1808B-B

PARTS LIST

ITEM	QTY	REFERENCE	PART DESCRIPTION	MANUFACTURER/PART NUMBER
Required Circuit Components				
1	5	C1, C11, C14, C17, C21	CAP, CHIP, X5R, 10 μ F, \pm 20%, 6.3V, 0603	TDK, C1608X5R0J106M
2	6	C2, C3, C4, C5, C6, C7	CAP, CHIP, X5R, 1 μ F, \pm 10%, 10V, 0402	MURATA, GRM155R61A105KE15D
3	5	C10, C13, C16, C19, C20	CAP, CHIP, X5R, 22 μ F, \pm 20%, 6.3V, 0805	TAIYO-YUDEN, JMK212ABJ226MG
4	3	C12, C15, C18	CAP, CHIP, COG, 10pF, \pm 0.5pF, 50V, 0402	TDK, C1005C0G1H100D
5	1	C22	CAP, CHIP, COG, 4.7pF, \pm 0.5pF, 50V, 0402	AVX, 04025A4R7DAT2A
6	1	L1	IND, SMT, 2.7 μ H, 47m Ω , \pm 30%, 2.20A, 4.8mm \times 4.8mm	WÜRTH, 7440420027
7	2	L2,L3	IND, SMT, 1.5 μ H, 36m Ω , \pm 20%, 5.8A, 4.2mm \times 4.2mm	COILCRAFT, XFL4020-152ME
8	1	L4	IND, SMT, 1.0 μ H, 29m Ω , \pm 20%, 6.5A, 4.2mm \times 4.2mm	COILCRAFT, XFL4020-102ME
9	2	R1, R55	RES, CHIP, 511k Ω , \pm 1%, 1/16W, 0402	VISHAY, CRCW0402511KFKED
10	1	R2	RES, CHIP, 1.02MEG Ω , \pm 1%, 1/16W, 0402	VISHAY, CRCW04021M02FKED
11	2	R3, R37	RES, CHIP, 604k Ω , \pm 1%, 1/16W, 0402	VISHAY, CRCW0402604KFKED
12	2	R4, R36	RES, CHIP, 768k Ω , \pm 1%, 1/16W, 0402	VISHAY, CRCW0402768KFKED
13	1	R27	RES, CHIP, 316k Ω , \pm 1%, 1/16W, 0402	VISHAY, CRCW0402316KFKED
14	1	R28	RES, CHIP, 1MEG Ω , \pm 1%, 1/16W, 0402	VISHAY, CRCW04021M00FKED
15	4	R29, R32, R35, R38	RES, CHIP, 20 Ω , \pm 5%, 1/16W, 0402	VISHAY, CRCW040220R0JNED
16	1	R30	RES, CHIP, 787k Ω , \pm 1%, 1/16W, 0402	VISHAY, CRCW0402787KFKED
17	1	R31	RES, CHIP, 681k Ω , \pm 1%, 1/16W, 0402	VISHAY, CRCW0402681KFKED
18	1	R33	RES, CHIP, 422k Ω , \pm 1%, 1/16W, 0402	VISHAY, CRCW0402422KFKED
19	1	R34	RES, CHIP, 715k Ω , \pm 1%, 1/16W, 0402	VISHAY, CRCW0402715KFKED
20	9	R43, R45, R47, R49, R50, R51, R53, R57, R58	RES, CHIP, 10k Ω , \pm 1%, 1/16W, 0402	VISHAY, CRCW040210K0FKED
21	3	R44, R46, R54	RES, CHIP, 18.2k Ω , \pm 1%, 1/16W, 0402	VISHAY, CRCW040218K2FKED
22	1	R48, R52	RES, CHIP, 9.09k Ω , \pm 1%, 1/10W, 0402	VISHAY, CRCW04029K09FKED
Additional Demo Board Circuit Components				
1	4	C8, C9, C25, C27	CAP, CHIP, X7R, 0.1 μ F, \pm 10%, 16V, 0402	MURATA, GRM155R71C104KA88S
2	2	C26, C28	CAP, CHIP, COG, 1000pF, \pm 5%, 50V, 0402	TDK, GRM1555C1H102J
3	2	C23, C24	CAP, CHIP, X5R, 2.2 μ F, \pm 20%, 6.3V, 0402	MURATA, GRM155R60J225ME95D
4	2	D1, D3	DIODE, LED, SUPER RED DIFF, 0603 SMD	LUMEX, SML-LX0603SRW-TR
5	1	D2	LED, AMBER HIGH BRIGHT ESS SMD, 0603	PANASONIC, LNJ436W82RA
6	1	D4	DIODE, SCHOTTKY, SMT, 20V, 0.5A, SOD123	ON SEMICONDUCTOR, MBR0520LG
7	1	D5	DIODE, Si SWITCHING, 100V, 80mA, SOD123	ON SEMICONDUCTOR, MMSD4148G
8	1	M1	MOSFET, 60V, 10 Ω , 115A, SOT-23	FAIRCHILD, 2N7002L
9	1	PB1	SWITCH TACTILE, SPST-NO, 0.05A, 12V	PANASONIC, EVQPNF04M
10	1	Q1	BITRANS., GP, SS, NPN, 40V, SOT-23	ON SEMICONDUCTOR, MMBT3904LG
11	4	R5, R10, R39, R56	RES, CHIP, 1k Ω , \pm 5%, 1/16W, 0402	VISHAY, CRCW04021K00JNED
12	5	R6, R7, R8, R9, R40	RES, CHIP, 100k Ω , \pm 5%, 1/16W, 0402	VISHAY, CRCW0402100KJNED
13	11	R11, R12, R13, R14, R15, R16, R17, R18, R19, R20, R21	RES, CHIP, 10k Ω , 5%, 1/16W, 0402	VISHAY, CRCW040210K0JNED

PARTS LIST

ITEM	QTY	REFERENCE	PART DESCRIPTION	MANUFACTURER/PART NUMBER
14	3	R22, R23, R25	RES, CHIP, 5.1k Ω , 5%, 1/16W, 0402	VISHAY, CRCW04025K10JNED
15	2	R24, R26	RES, CHIP, 4.7k Ω , \pm 5%, 1/16W, 0402	VISHAY, CRCW04024K70JNED
16	2	R41, R42	RES,CHIP, 100k Ω , \pm 1%, 1/16W, 0402	VISHAY, CRCW0402100KFKED
17	1	SW1	SWITCH, SMT, SPDT, 6 Pos. DIP, 37mm \times 8mm	CTS ELECTROCOMPONENTS, 204-126-LPST
18	1	U2	I ² C EEPROM	MICROCHIP, 24LC025-I/ST
19	1	U3	PIC MICROCONTROLLER, 6mm \times 6mm QFN16	MICROCHIP, PIC16F722-I/ML
20	1	U4	LOW NOISE REGULATED CHARGE PUMP IN 2mm \times 2mm DFN	LINEAR TECHNOLOGY, LTC3204BEDC-5

Hardware: For Demo Board Only

1	18	E1-E4, E6-E7, E9-E12, E27-E34	TURRET, 0.09, DIA	MILL-MAX, 2501-2-00-80-00-00-07-0
2	16	E5, E8, E13-E26	TURRET, 0.061, DIA	MILL-MAX, 2308-2-00-80-00-00-07-0
3	1	J2	HEADER, 2 \times 3, 0.079, DOUBLE ROW	SULLINS, NRPN032PAEN-RC
4	1	J3	CONN, HEADER, 14 POS, 2mm, VERT GOLD	MOLEX, 87831-1420
5	2	JP1, JP2	HEADER, 1 \times 4 PIN, 0.079, SINGLE ROW	SULLINS, NRPN041PAEN-RC
6	1	JP3	HEADER, 1 \times 3 PIN, 0.079, SINGLE ROW	SULLINS, NRPN031PAEN-RC
7	3	JP1-JP3	SHUNT, 0.079", CENTER	SAMTEC, 2SN-KB-G
8	4		STAND-OFF, NYLON, 0.375" TALL, (SNAP-ON)	KEYSTONE, 8832 (SNAP-ON)
9	1		FAB, PRINTED CIRCUIT BOARD	DEMO CIRCUIT 1808B-1

DC1808B-A Required Circuit Components

1	1	U1	8-OUTPUT REGULATOR WITH SEQUENCING AND I ² C	LINEAR TECHNOLOGY, LTC3589HUJ-1
---	---	----	---	---------------------------------

DC1808B-B Required Circuit Components

1	1	U1	8-OUTPUT REGULATOR WITH SEQUENCING AND I ² C	LINEAR TECHNOLOGY, LTC3589HUJ-2
---	---	----	---	---------------------------------

DEMO MANUAL

DC1808B-A/DC1808B-B

SCHEMATIC DIAGRAM

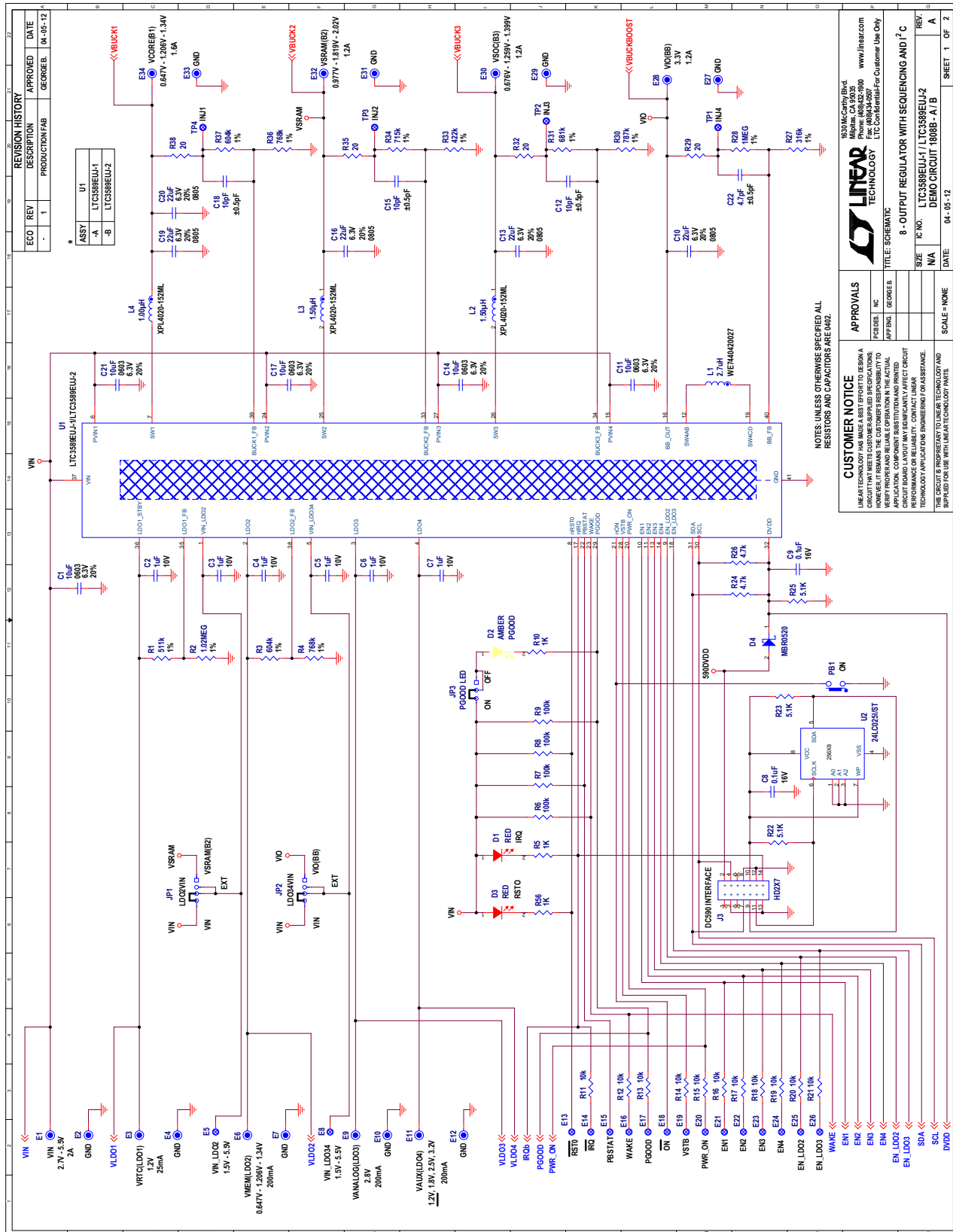
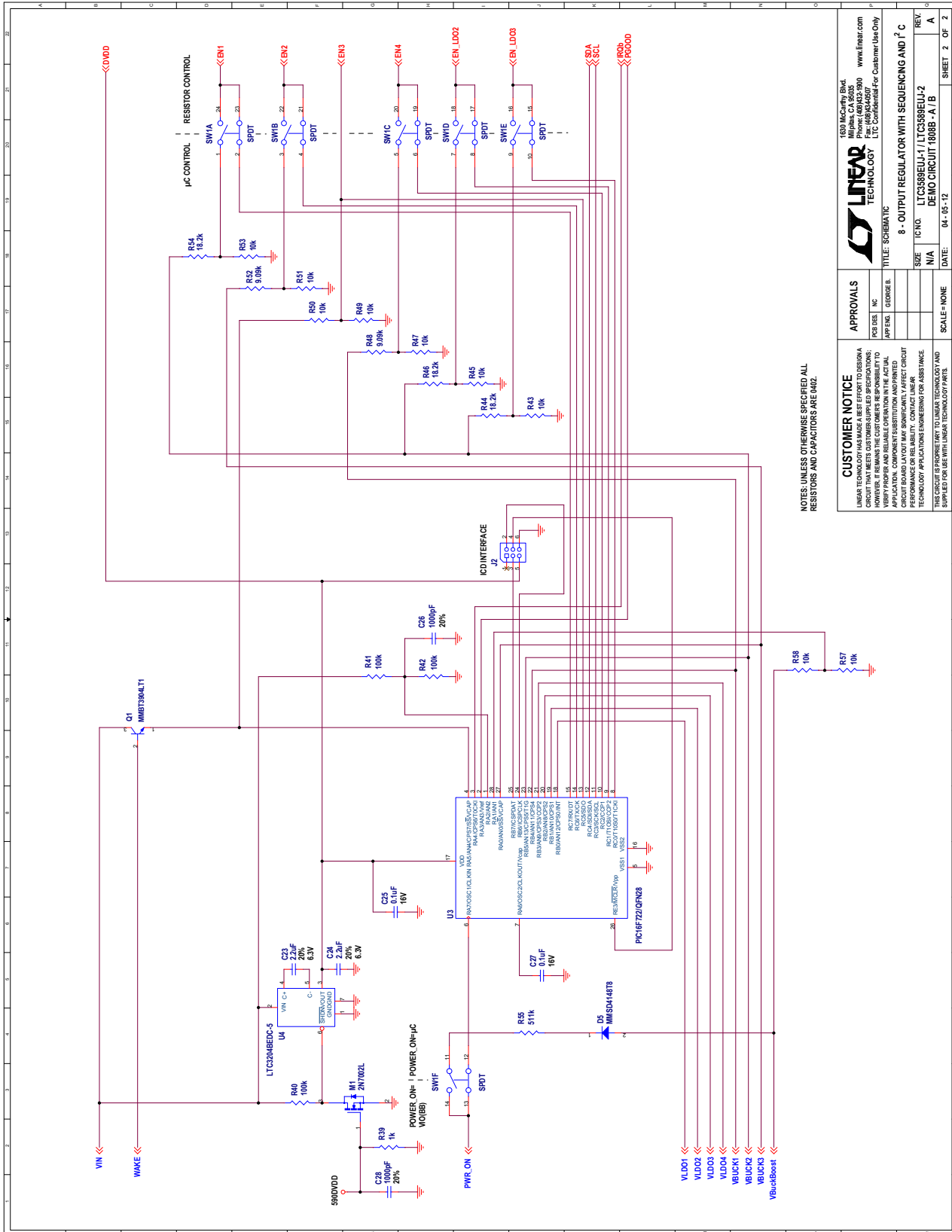

Figure 9. 8-Output Regulator with Sequencing and I²C

SCHEMATIC DIAGRAM



NOTES: UNLESS OTHERWISE SPECIFIED ALL RESISTORS AND CAPACITORS ARE 0402.

CUSTOMER NOTICE LINEAR TECHNOLOGY HAS MADE A BEST EFFORT TO DESIGN A CIRCUIT THAT MEETS CUSTOMER-SUPPLIED SPECIFICATIONS. LINEAR TECHNOLOGY DOES NOT WARRANT THE PERFORMANCE OF ANY APPLICATION. COMPONENT SUBSTITUTION AND PRINTED CIRCUIT BOARD LAYOUT MAY SIGNIFICANTLY AFFECT CIRCUIT PERFORMANCE. CUSTOMER APPLICATIONS ENGINEERING FOR ASSISTANCE SHOULD BE CONTACTED AT 978.328.2000. LINEAR TECHNOLOGY PARTS ARE SUPPLIED FOR USE WITH LINEAR TECHNOLOGY PARTS.	
APPROVALS PCB DES: _____ APP ENG: GEORGE B. _____ SCALE: NONE	
LINEAR TECHNOLOGY 160 McLean Blvd. Phone: (978)328-2900 Fax: (978)328-4500 www.linear.com LTC Confidential For Customer Use Only	
8-OUTPUT REGULATOR WITH SEQUENCING AND I²C I.C. NO: LT3380BDC-5 / LT3380BDC-5 DEMO CIRCUIT: 1808B-A / B DATE: 04-05-12 SHEET 2 OF 2	

Figure 10. 8-Output Regulator with Sequencing and I²C

DEMO MANUAL

DC1808B-A/DC1808B-B

DEMONSTRATION BOARD IMPORTANT NOTICE

Linear Technology Corporation (LTC) provides the enclosed product(s) under the following **AS IS** conditions:

This demonstration board (DEMO BOARD) kit being sold or provided by Linear Technology is intended for use for **ENGINEERING DEVELOPMENT OR EVALUATION PURPOSES ONLY** and is not provided by LTC for commercial use. As such, the DEMO BOARD herein may not be complete in terms of required design-, marketing-, and/or manufacturing-related protective considerations, including but not limited to product safety measures typically found in finished commercial goods. As a prototype, this product does not fall within the scope of the European Union directive on electromagnetic compatibility and therefore may or may not meet the technical requirements of the directive, or other regulations.

If this evaluation kit does not meet the specifications recited in the DEMO BOARD manual the kit may be returned within 30 days from the date of delivery for a full refund. **THE FOREGOING WARRANTY IS THE EXCLUSIVE WARRANTY MADE BY THE SELLER TO BUYER AND IS IN LIEU OF ALL OTHER WARRANTIES, EXPRESSED, IMPLIED, OR STATUTORY, INCLUDING ANY WARRANTY OF MERCHANTABILITY OR FITNESS FOR ANY PARTICULAR PURPOSE. EXCEPT TO THE EXTENT OF THIS INDEMNITY, NEITHER PARTY SHALL BE LIABLE TO THE OTHER FOR ANY INDIRECT, SPECIAL, INCIDENTAL, OR CONSEQUENTIAL DAMAGES.**

The user assumes all responsibility and liability for proper and safe handling of the goods. Further, the user releases LTC from all claims arising from the handling or use of the goods. Due to the open construction of the product, it is the user's responsibility to take any and all appropriate precautions with regard to electrostatic discharge. Also be aware that the products herein may not be regulatory compliant or agency certified (FCC, UL, CE, etc.).

No License is granted under any patent right or other intellectual property whatsoever. **LTC assumes no liability for applications assistance, customer product design, software performance, or infringement of patents or any other intellectual property rights of any kind.**

LTC currently services a variety of customers for products around the world, and therefore this transaction **is not exclusive**.

Please read the DEMO BOARD manual prior to handling the product. Persons handling this product must have electronics training and observe good laboratory practice standards. **Common sense is encouraged.**

This notice contains important safety information about temperatures and voltages. For further safety concerns, please contact a LTC application engineer.

Mailing Address:

Linear Technology
1630 McCarthy Blvd.
Milpitas, CA 95035

Copyright © 2004, Linear Technology Corporation