

# 500mA, 1.25MHz Synchronous Step-Up DC/DC Converter in 2mm × 2mm DFN Package

## FEATURES

- **High Efficiency: Up to 94%**
- **3.3V at 200mA from Two Alkaline Cells**
- **5V at 200mA from a Single Li-Ion Cell**
- **Inrush Current Limiting and Soft-Start**
- **Output Disconnect in Shutdown**
- 1.8V to 5V  $V_{IN}$  Range
- 1.8V to 5.25V  $V_{OUT}$  Range
- 1.25MHz Fixed Frequency, Low Noise PWM
- Internal Synchronous Rectifier
- Logic Controlled Shutdown ( $<1\mu A$ )
- Anti-Ringing Control Minimizes EMI
- Tiny External Components
- Short-Circuit Protection
- Low Profile (0.75mm × 2mm × 2mm) DFN Package

## APPLICATIONS

- Handheld Instruments
- Digital Cameras
- Wireless Handsets
- GPS Receivers
- Portable Medical Devices
- MP3 Players

## DESCRIPTION

The LTC<sup>®</sup>3427 is the industry's first high efficiency, fixed frequency, step-up DC/DC converter with true output disconnect in a 6-lead 2mm × 2mm DFN package. Requiring minimal external components, the LTC3427 operates from an input voltage as low as 1.8V. The LTC3427 contains an internal 0.525Ω N-channel MOSFET switch and a 0.575Ω P-channel MOSFET synchronous rectifier, which enables it to supply 200mA at 3.3V from a 2-cell alkaline battery input.

The LTC3427 limits inrush current during start-up and provides a soft-start of  $V_{OUT}$ . A switching frequency of 1.25MHz minimizes solution footprint by allowing the use of tiny, low profile inductors and ceramic capacitors and produces very low  $V_{OUT}$  ripple. The current mode PWM design is internally compensated, reducing external parts count. Anti-ringing control reduces EMI in discontinuous mode operation. The LTC3427 also features low shutdown current of under 1μA and thermal shutdown.

LT, LTC and LTM are registered trademarks of Linear Technology Corporation. All other trademarks are the property of their respective owners.

## TYPICAL APPLICATION

**2-Cell Alkaline to 3.3V Synchronous Boost Converter**

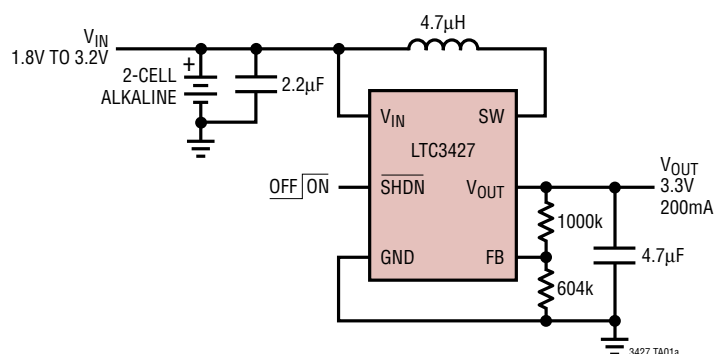

**2.4V to 3.3V Efficiency**

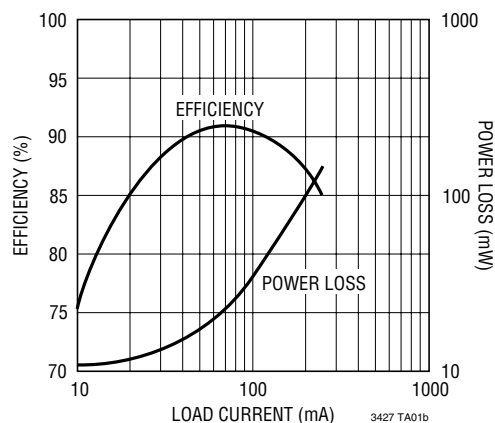

## ABSOLUTE MAXIMUM RATINGS

(Note 1)

$V_{IN}$ , $V_{OUT}$ Voltages .....	-0.3V to 6V
SHDN, FB Voltages .....	-0.3V to 6V
SW Voltage	
DC .....	-0.3V to 6V
Pulsed < 100ns .....	-0.3V to 7V
Operating Temperature Range	
(Notes 2, 5) .....	-40°C to 85°C
Storage Temperature Range .....	-65°C to 125°C

## PACKAGE/ORDER INFORMATION

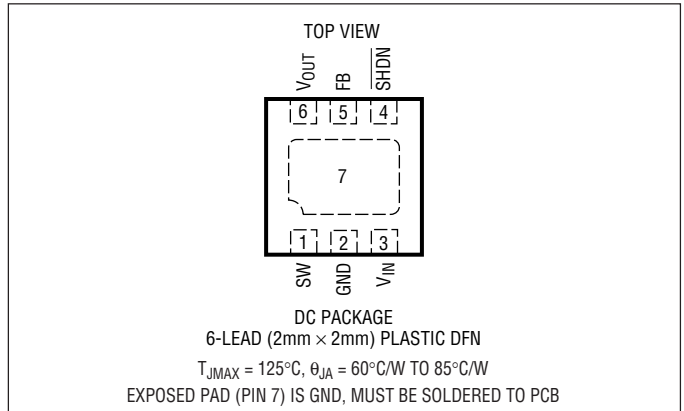

ORDER PART NUMBER	DC PART MARKING
LTC3427EDC	LBSY
<b>Order Options</b> Tape and Reel: Add #TR Lead Free: Add #PBF Lead Free Tape and Reel: Add #TRPBF Lead Free Part Marking: <a href="http://www.linear.com/leadfree/">http://www.linear.com/leadfree/</a>	

Consult LTC Marketing for parts specified with wider operating temperature ranges.

## ELECTRICAL CHARACTERISTICS

The ● denotes specifications which apply over the full operating temperature range, otherwise specifications are  $T_A = 25^{\circ}C$ .

$V_{IN} = 2.4V$ ,  $V_{OUT} = 3.3V$  unless otherwise specified.

PARAMETER	CONDITIONS		MIN	TYP	MAX	UNITS
Minimum Start-Up Voltage	$I_{LOAD} < 1mA$	●		1.6	1.8	V
Output Voltage Adjust Range		●	1.8		5.25	V
Feedback Voltage		●	1.215	1.24	1.265	V
Feedback Input Current	$V_{FB} = 1.24V$			1	50	nA
Quiescent Current—Shutdown	$V_{SHDN} = 0V$ , $V_{OUT} = 0V$			0.01	1	$\mu A$
Quiescent Current—Active	$V_{FB} = 1.5V$ (Note 3)			350	550	$\mu A$
NMOS Switch Leakage				0.1	5	$\mu A$
PMOS Switch Leakage				0.1	5	$\mu A$
NMOS Switch-On Resistance				0.525		$\Omega$
PMOS Switch-On Resistance				0.575		$\Omega$
NMOS Current Limit		●	500			mA
Current Limit Delay to Output	(Note 4)			40		ns
Maximum Duty Cycle	$V_{FB} = 1V$	●	80	87		%
Minimum Duty Cycle	$V_{FB} = 1.5V$	●			0	%
Frequency		●	0.9	1.25	1.5	MHz
SHDN Input High			1			V
SHDN Input Low					0.35	V
SHDN Input Current	$V_{SHDN} = 5.5V$			0.01	1	$\mu A$
Soft-Start Time				2		ms

## ELECTRICAL CHARACTERISTICS

**Note 1:** Stresses beyond those listed under Absolute Maximum Ratings may cause permanent damage to the device. Exposure to any Absolute Maximum Rating condition for extended periods may affect device reliability and lifetime.

**Note 2:** The LTC3427E is guaranteed to meet performance specifications from 0°C to 70°C. Specifications over the -40°C to 85°C operating temperature range are assured by design, characterization and correlation with statistical process controls.

**Note 3:** Current is measured into the  $V_{OUT}$  pin since the supply current is bootstrapped to the output. The current will reflect to the input supply by:  $(V_{OUT}/V_{IN}) \cdot \text{Efficiency}$ . The outputs are not switching.

**Note 4:** Specification is guaranteed by design and not 100% tested in production.

**Note 5:** The LTC3427 includes an overtemperature shutdown that is intended to protect the device during momentary overload conditions. Junction temperature will exceed 125°C when the overtemperature shutdown is active. Continuous operation above the specified maximum operating junction temperature may impair device reliability.

## TYPICAL PERFORMANCE CHARACTERISTICS $T_A = 25^\circ\text{C}$ unless otherwise specified.

2-Cell Alkaline to 3.3V Efficiency

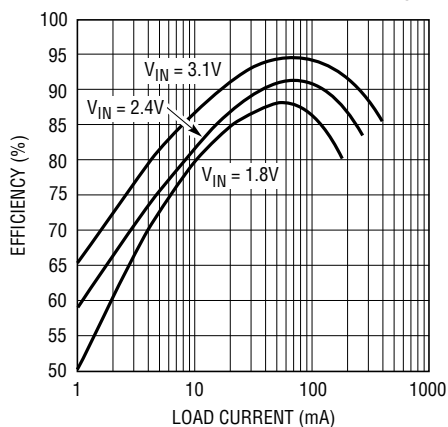

Li-Ion to 5V Efficiency

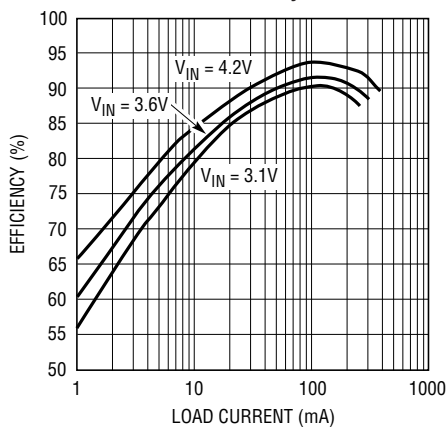

2-Cell Alkaline to 5V Efficiency

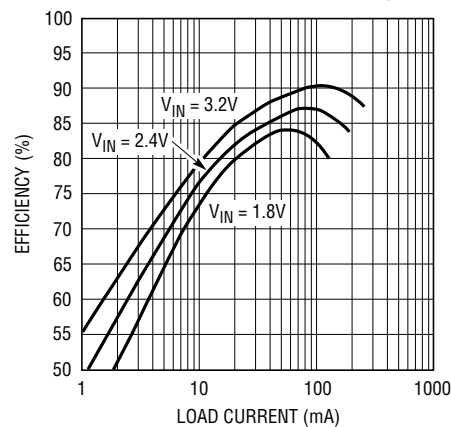

Inrush Current Control

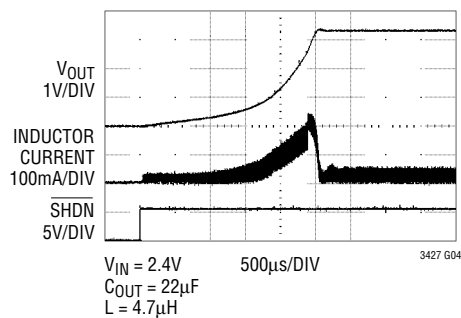

Load Transient Response

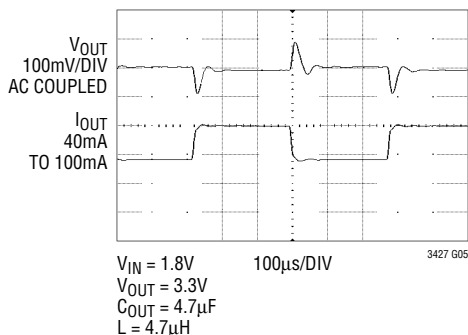

$V_{OUT}$  Ripple, AC Coupled

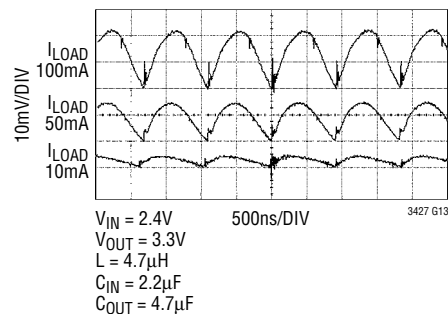

## TYPICAL PERFORMANCE CHARACTERISTICS T<sub>A</sub> = 25°C unless otherwise specified.

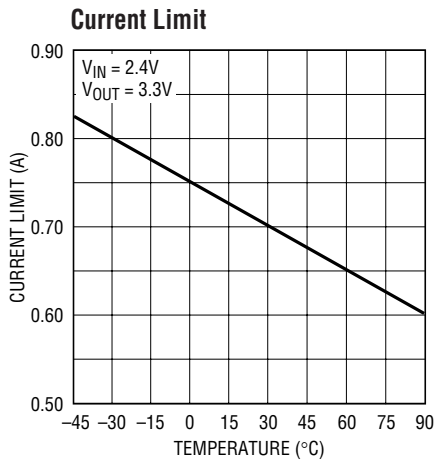

3427 G06

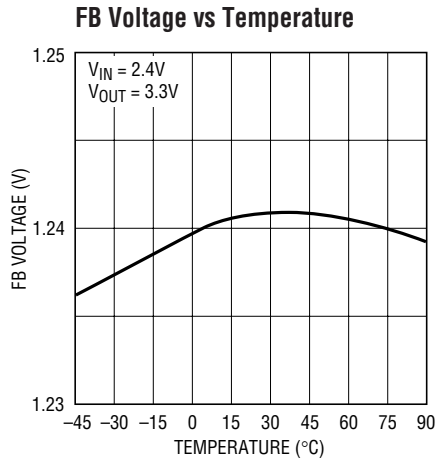

3427 G07

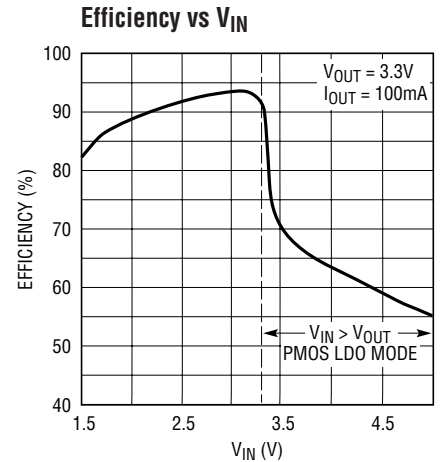

3427 G08

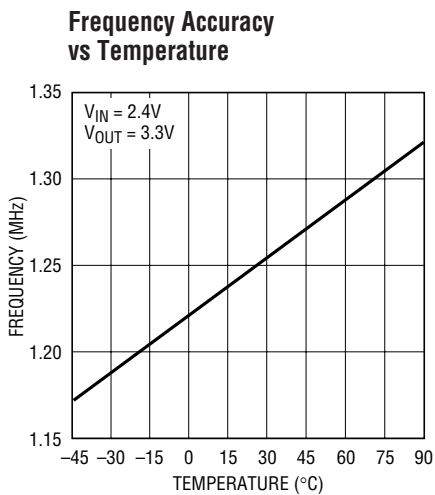

3427 G09

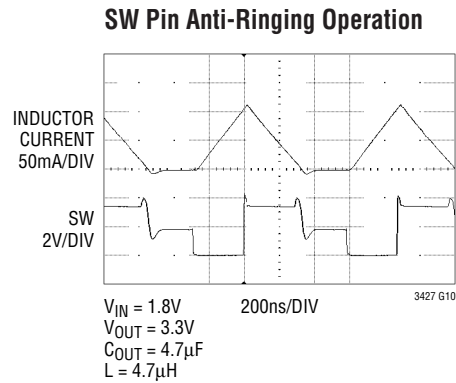

3427 G10

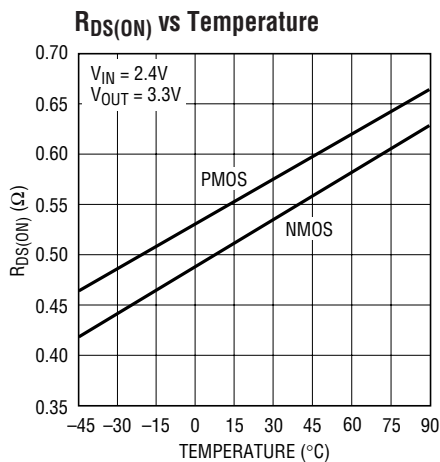

3427 G11

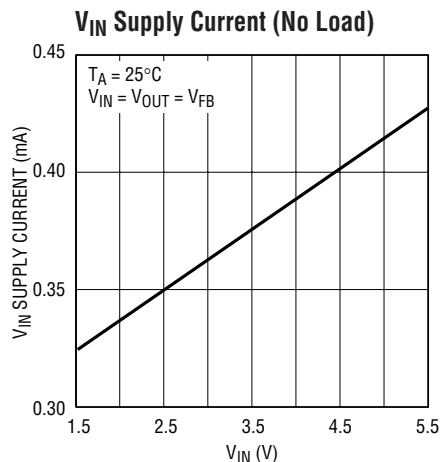

3427 G12

## PIN FUNCTIONS

**SW (Pin 1):** Switch Pin for the Inductor Connection. Minimize trace length between SW and the inductor. For discontinuous inductor current, an internal  $200\Omega$  impedance is connected from SW to  $V_{IN}$  to eliminate high frequency ringing, reducing EMI radiation.

**GND (Pin 2):** Signal and Power Ground. Provide a short, direct PCB path between GND and the (-) side of the input and output capacitor(s).

**$V_{IN}$  (Pin 3):** Input Supply Voltage. Connect  $V_{IN}$  to the input supply and decouple with a  $2.2\mu\text{F}$  or larger ceramic capacitor as close to  $V_{IN}$  as possible.

**SHDN (Pin 4):** Shutdown Input. Less than  $350\text{mV}$  on SHDN shuts down the LTC3427. Placing  $1\text{V}$  or more on SHDN enables the LTC3427.

**FB (Pin 5):** Feedback Input to the Error Amplifier. Connect resistor divider tap to this pin. Referring to the Block Diagram,  $V_{OUT}$  can be adjusted from  $1.8\text{V}$  to  $5.25\text{V}$  by:

$$V_{OUT} = 1.24\text{V} \cdot \left(1 + \frac{R1}{R2}\right)$$

**$V_{OUT}$  (Pin 6):** Output Voltage Sense Input and Drain of the Internal Synchronous Rectifier MOSFET. Driver bias is derived from  $V_{OUT}$ . PCB trace length from  $V_{OUT}$  to the output filter capacitor(s) should be as short and wide as possible.

**Exposed Pad (Pin 7):** Ground for the LTC3427. This pin must be soldered to the PCB ground plane for electrical connection and rated thermal performance.

## BLOCK DIAGRAM

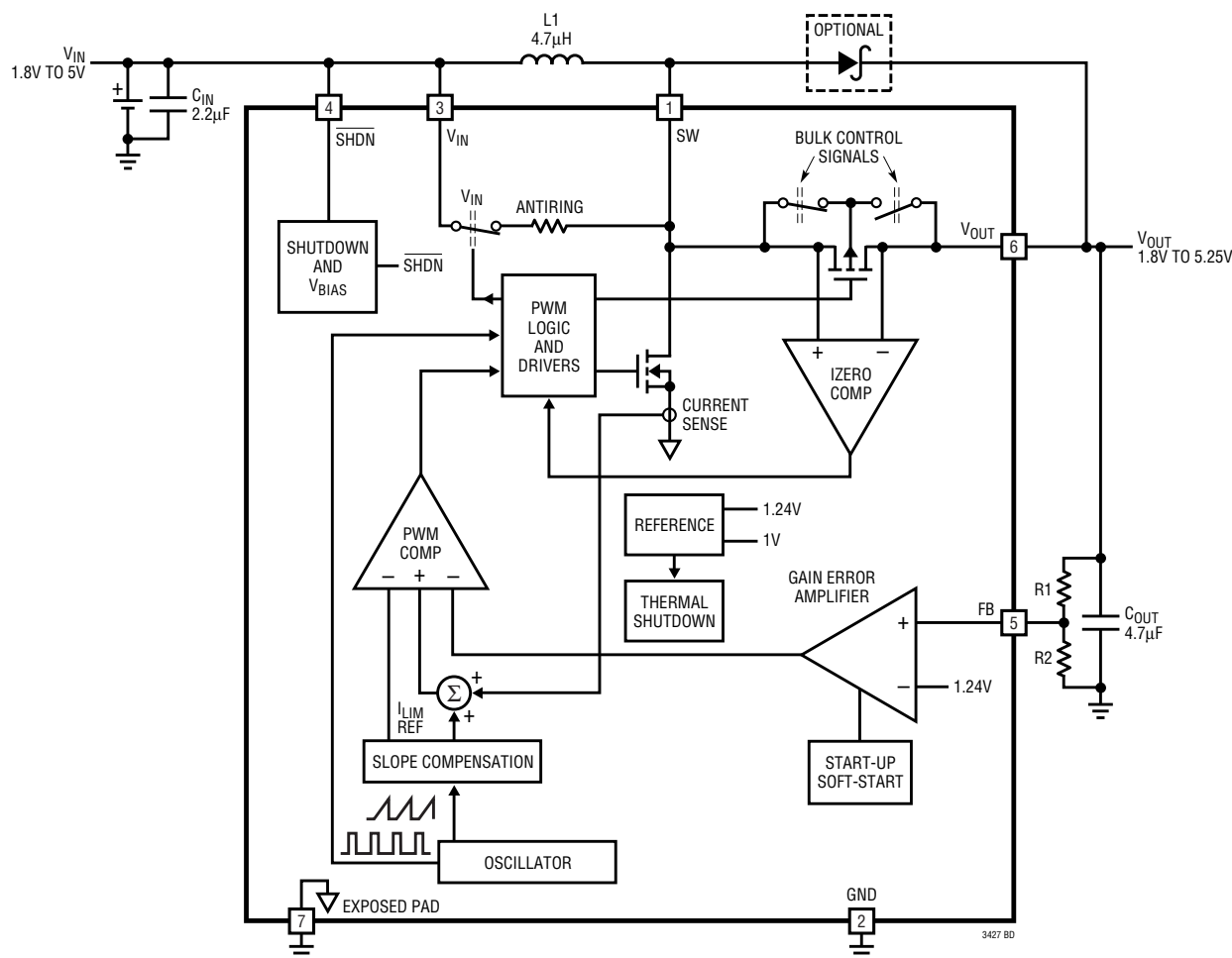

3427fa

## OPERATION (Refer to Block Diagram)

### LOW NOISE FIXED FREQUENCY OPERATION

#### Shutdown

The LTC3427 is shut down by pulling the  $\overline{\text{SHDN}}$  pin below 0.35V, and activated by pulling the  $\overline{\text{SHDN}}$  pin above 1V. Note that  $\overline{\text{SHDN}}$  can be driven above  $V_{\text{IN}}$  or  $V_{\text{OUT}}$  as long as it is limited to less than the absolute maximum rating.

#### Soft-Start

The LTC3427 provides soft-start by ramping the peak inductor current from zero to its peak value of 500mA. The soft-start time is typically 2ms. A soft-start cycle is re-initiated in the event of a commanded shutdown or a thermal shutdown.

#### Oscillator

The frequency of operation is set by an internal oscillator to 1.25MHz for the LTC3427.

#### Error Amplifier

The error amplifier is a transconductance type with its positive input internally connected to the 1.24V reference and the negative input connected to FB. Internal clamps limit the minimum and maximum error amplifier output voltage for improved large-signal transient response. Power converter control loop compensation is provided internally by the error amplifier. A voltage divider from  $V_{\text{OUT}}$  to ground programs the output voltage via FB from 1.8V to 5.25V.

$$V_{\text{OUT}} = 1.24\text{V} \cdot \left( 1 + \frac{R1}{R2} \right)$$

The error amplifier also provides a soft-start feature internal to the device.

#### Current Sensing

Lossless current sensing converts the peak current signal of the N-channel MOSFET switch into a voltage that is summed with the internal slope compensation. The summed signal is compared to the error amplifier output to provide a peak current control command for the PWM. Peak switch current is limited to 500mA minimum, independent

of input or output voltage. The current signal is blanked for approximately 25ns to enhance noise rejection.

#### Current Limit

The current limit circuitry shuts off the internal N-channel MOSFET switch when the current limit threshold is reached. The current limit comparator delay to output is typically 40ns.

#### Zero Current Comparator

The zero current comparator monitors the inductor current to the output and shuts off the synchronous rectifier once this current reduces to approximately 20mA.

#### Anti-Ringing Control

The anti-ringing control connects a resistor across the inductor to damp the ringing on the SW pin in discontinuous conduction mode. The  $LC_{\text{SW}}$  ringing ( $L$  = Inductor,  $C_{\text{SW}}$  = capacitance on the SW pin) is low energy, but can cause EMI radiation.

#### Output Disconnect and Inrush Limiting

The LTC3427 provides true output disconnect by eliminating body diode conduction of the internal P-channel MOSFET rectifier. This allows  $V_{\text{OUT}}$  to go to zero volts during shutdown without drawing any current from the input source. It also provides inrush current limiting at turn-on, minimizing surge currents seen by the input supply. Note that to obtain the advantages of output disconnect, there must not be any external Schottky diode connected between SW and  $V_{\text{OUT}}$ .

#### Thermal Shutdown

If the die temperature reaches approximately 145°C, the part will go into thermal shutdown. All switches will be turned off. The device will be enabled and initiate a soft-start sequence when the die temperature drops by approximately 10°C.

**Note:** Due to the high frequency operation of the LTC3427, board layout is extremely critical to minimize transients due to stray inductance. Keep the output filter capacitor as close as possible to the  $V_{\text{OUT}}$  pin and use very low ESR/ESL ceramic capacitors tied to a good ground plane.

## APPLICATIONS INFORMATION

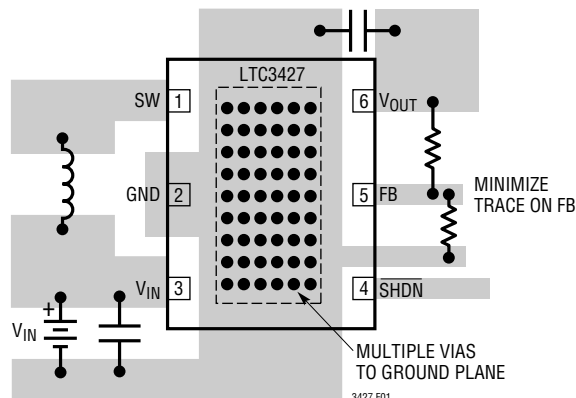

**Figure 1. Recommended Component Placement for a Single Layer Board. Traces Carrying High Current are Direct (GND, SW,  $V_{IN}$ ,  $V_{OUT}$ ). Trace Area at FB is Kept Low. Lead Length to Battery Should be Kept Short.  $V_{IN}$  and  $V_{OUT}$  Ceramic Capacitors Should be as Close to the LTC3427 as Possible. A Multilayer Board with a Separate Ground Plane is Ideal, but not Absolutely Necessary**

### COMPONENT SELECTION

#### Inductor Selection

The LTC3427 can utilize small surface mount and chip inductors due to its fast 1.25MHz switching frequency. A minimum inductance value of 3.3 $\mu$ H is necessary for 3.6V and lower voltage applications and a 4.7 $\mu$ H for output voltages greater than 3.6V. Larger values of inductance will allow greater output current capability by reducing the inductor ripple current. Increasing the inductance above 10 $\mu$ H will increase size while providing little improvement in output current capability.

The approximate output current capability of the LTC3427 vs Inductance value is given below in Equation 1 and illustrated graphically in Figure 2.

$$I_{OUT(MAX)} = n \cdot \left( I_P - \frac{V_{IN} \cdot D}{f \cdot L \cdot 2} \right) \cdot (1 - D) \quad (1)$$

where:

$n$  = estimated efficiency

$I_P$  = peak current limit value (0.5A min)

$V_{IN}$  = input (battery) voltage

$D$  = steady-state duty ratio =  $(V_{OUT} - V_{IN})/V_{OUT}$

$f$  = switching frequency (1.25MHz typical)

$L$  = inductance value

The inductor current ripple is typically set for 20% to 40% of the maximum inductor current ( $I_P$ ). High frequency ferrite core inductor materials reduce frequency dependent power losses compared to cheaper powdered iron types, improving efficiency. The inductor should have low ESR (series resistance of the windings) to reduce the  $I^2R$  power losses, and must be able to handle the peak inductor current without saturating. Molded chokes and some chip inductors usually do not have enough core to support the peak inductor currents of greater than 500mA seen on the LTC3427. To minimize radiated noise, use a toroid, pot core or shielded bobbin inductor. See Table 1 for suggested suppliers.

#### Output and Input Capacitor Selection

Low ESR (equivalent series resistance) capacitors should be used to minimize the output voltage ripple. Multilayer ceramic capacitors are an excellent choice as they have extremely low ESR and are available in small footprints. A 2.2 $\mu$ F to 10 $\mu$ F output capacitor is sufficient for most applications. Larger values up to 22 $\mu$ F may be used to obtain extremely low output voltage ripple and improve transient response. An additional phase lead capacitor may be required with output capacitors larger than 10 $\mu$ F to maintain acceptable phase margin. X5R and X7R dielectric materials are preferred for their ability to maintain capacitance over wide voltage and temperature ranges.



## APPLICATIONS INFORMATION

**Table 1. Inductor Vendor Information**

SUPPLIER	PHONE	FAX	WEBSITE
Murata	USA: (814) 237-1431 (800) 831-9172	USA: (814) 238-0490	www.murata.com
Sumida	USA: (847) 956-0666 Japan: 81-3-3607-5111	USA: (847) 956-0702 Japan: 81-3-3607-5144	www.sumida.com
Coilcraft	(847) 639-6400	(847) 639-1469	www.coilcraft.com
CoEv Magnetics	(800) 227-7040	(650) 361-2508	www.circuitprotection.com/magnetics.asp
TDK	(847) 803-6100	(847) 803-6296	www.component.tdk.com
TOKO	(847) 297-0070	(847) 669-7864	www.toko.com
Würth	(201) 785-8800	(201) 785-8810	www.we-online.com

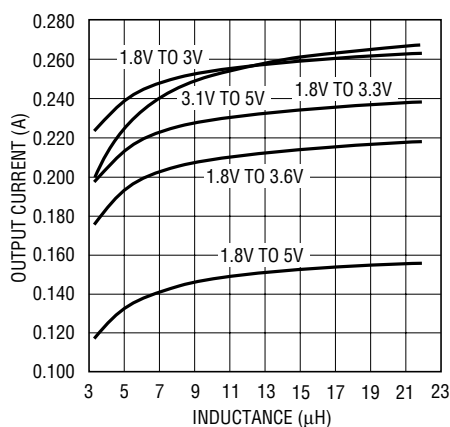

3427 F02

**Figure 2. Maximum Output Current vs Inductance Based on 90% Efficiency**

Low ESR input capacitors reduce input switching noise and reduce the peak current drawn from the battery. It follows that ceramic capacitors are also a good choice for input decoupling and should be located as close as possible to the device. A 2.2 $\mu$ F input capacitor is sufficient for virtually any application. Larger values may be used without limitations. Table 2 shows a list of several ceramic capacitor manufacturers. Consult the manufacturers directly for detailed information on their entire selection of ceramic capacitors.

**Table 2. Capacitor Vendor Information**

SUPPLIER	PHONE	FAX	WEBSITE
AVX	(803) 448-9411	(803) 448-1943	www.avxcorp.com
Sanyo	(619) 661-6322	(619) 661-1055	www.sanyovideo.com
TDK	(847) 803-6100	(847) 803-629	www.component.tdk.com
Murata	USA: (814) 237-1431 (800) 831-9172	USA: (814) 238-0490	www.murata.com
Taiyo Yuden	(408) 573-4150	(408) 573-4159	www.t-yuden.com

### Thermal Considerations

To deliver the power that the LTC3427 is capable of, it is imperative that a good thermal path be provided to dissipate the heat generated within the package. This can be accomplished by taking advantage of the large thermal pad on the underside of the LTC3427. It is recommended that multiple vias in the printed circuit board be used to conduct heat away from the LTC3427 and into the copper plane with as much area as possible. In the event that the junction temperature gets too high, the LTC3427 will go into thermal shutdown and all switching will stop until the internal temperature drops at which point a soft-start cycle will be initiated.



## APPLICATIONS INFORMATION

### $V_{IN} > V_{OUT}$ Operation

The LTC3427 will maintain voltage regulation when the input voltage is above the output voltage. This is achieved by terminating the switching of the synchronous P-channel MOSFET and applying  $V_{IN}$  statically on its gate. This will ensure the volt • seconds across the inductor reverse during the time current is flowing to the output. Since this mode will dissipate more power in the LTC3427, the maximum output current is limited in order to maintain an acceptable junction temperature and is given by:

$$I_{OUT(MAX)} = \frac{125 - T_A}{85 \cdot [(V_{IN} + 1.5) - V_{OUT}]}$$

where  $T_A$  = ambient temperature.

For example at  $V_{IN} = 4.5V$ ,  $V_{OUT} = 3.3V$ , and  $T_A = 85^\circ C$ , the maximum output current is 145mA.

### Short-Circuit Protection

The LTC3427 output disconnect feature allows output short circuit while maintaining a maximum internally set current limit. However, the LTC3427 also incorporates internal features such as current limit foldback and thermal shutdown for protection from an excessive overload or short circuit. During a prolonged short circuit the current limit folds back to a typical value of approximately 400mA should  $V_{OUT}$  drop below 950mV. This 400mA current limit remains in effect until  $V_{OUT}$  exceeds approximately 1V, at which time the nominally internally set current limit is restored.

TYPICAL APPLICATIONS

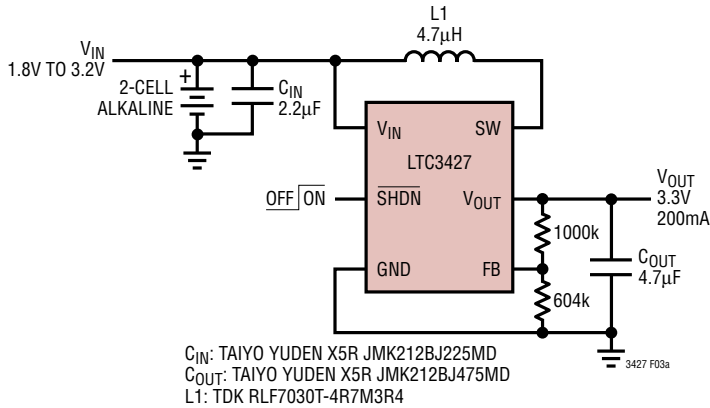

Figure 3. 2-Cell Alkaline to 3.3V Synchronous Boost Converter

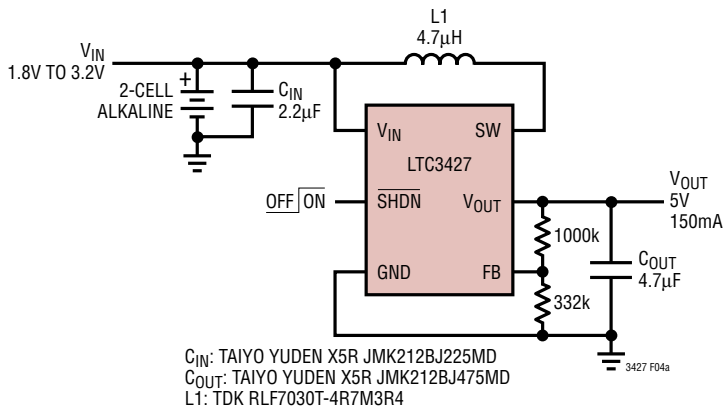
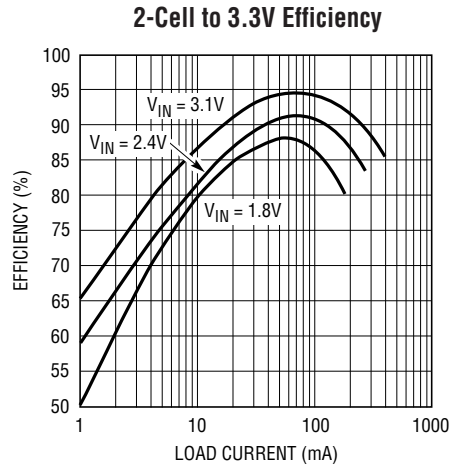
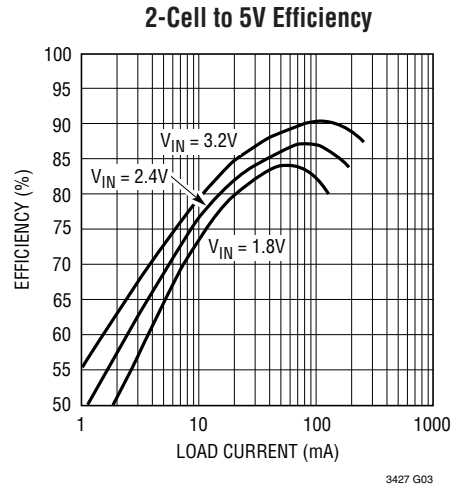
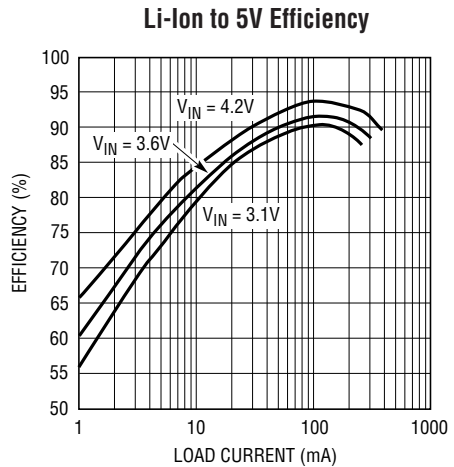
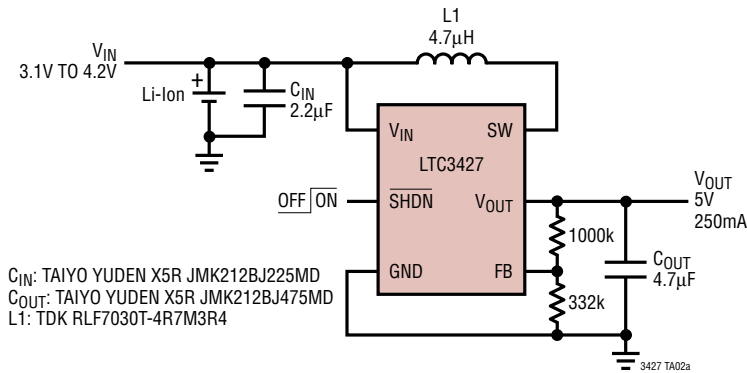

Figure 4. 2-Cell Alkaline to 5V Synchronous Boost Converter with Output Disconnect



Li-Ion to 5V Synchronous Boost Converter





## RELATED PARTS

PART NUMBER	DESCRIPTION	COMMENTS
LT <sup>®</sup> 1613	800mA I <sub>SW</sub> , 1.4MHz, Step-Up DC/DC Converter	V <sub>IN</sub> : 1.1V to 10V, V <sub>OUT(MAX)</sub> = 34V, I <sub>Q</sub> = 3mA, I <sub>SD</sub> < 1μA, 5-Lead SOT-23 Package
LT1615	350mA I <sub>SW</sub> , Micropower, Step-Up DC/DC Converter	V <sub>IN</sub> : 1.2V to 15V, V <sub>OUT(MAX)</sub> = 34V, I <sub>Q</sub> = 20μA, I <sub>SD</sub> < 1μA, ThinSOT™ Package
LT1618	1.5A I <sub>SW</sub> , 1.4MHz, Constant Current/Constant Voltage Step-Up DC/DC Converter	V <sub>IN</sub> : 1.6V to 18V, V <sub>OUT(MAX)</sub> = 35V, I <sub>Q</sub> = 1.8mA, I <sub>SD</sub> < 1μA, DFN, MSOP Packages
LT1930/LT1930A	1A I <sub>SW</sub> , 1.2MHz/2.2MHz, Step-Up DC/DC Converters	V <sub>IN</sub> : 2.6V to 16V, V <sub>OUT(MAX)</sub> = 34V, I <sub>Q</sub> = 4.2mA/5.5mA, I <sub>SD</sub> < 1μA, ThinSOT Package
LTC3400/LTC3400B	600mA I <sub>SW</sub> , 1.2MHz, Synchronous Step-Up DC/DC Converters	92% Efficiency V <sub>IN</sub> : 0.85V to 5V, V <sub>OUT(MAX)</sub> = 5V, I <sub>Q</sub> = 19μA/300μA, I <sub>SD</sub> < 1μA, ThinSOT Package
LTC3401	1A I <sub>SW</sub> , 3MHz, Synchronous Step-Up DC/DC Converter	97% Efficiency V <sub>IN</sub> : 0.5V to 5V, V <sub>OUT(MAX)</sub> = 6V, I <sub>Q</sub> = 38μA, I <sub>SD</sub> < 1μA, 10-Lead MS Package
LTC3402	2A I <sub>SW</sub> , 3MHz, Synchronous Step-Up DC/DC Converter	97% Efficiency V <sub>IN</sub> : 0.5V to 5V, V <sub>OUT(MAX)</sub> = 6V, I <sub>Q</sub> = 38μA, I <sub>SD</sub> < 1μA, 10-Lead MS Package
LTC3421	3A I <sub>SW</sub> , 3MHz, Synchronous Step-Up DC/DC Converter with Output Disconnect	95% Efficiency V <sub>IN</sub> : 0.5V to 4.5V, V <sub>OUT(MAX)</sub> = 5.25V, I <sub>Q</sub> = 12μA, I <sub>SD</sub> < 1μA, QFN24 Package
LTC3422	1.5A I <sub>SW</sub> , 3MHz Synchronous Step-Up DC/DC Converter with Output Disconnect	95% Efficiency V <sub>IN</sub> : 0.5V to 4.5V, V <sub>OUT(MAX)</sub> = 5.25V, I <sub>Q</sub> = 25μA, I <sub>SD</sub> < 1μA, 3mm × 3mm DFN Package
LTC3423/LTC3424	1A/2A I <sub>SW</sub> , 3MHz, Synchronous Step-Up DC/DC Converter	95% Efficiency V <sub>IN</sub> : 0.5V to 5.5V, V <sub>OUT(MAX)</sub> = 5.5V, I <sub>Q</sub> = 38μA, I <sub>SD</sub> < 1μA, 10-Lead MS Package
LTC3426	2A I <sub>SW</sub> , 1.2MHz, Step-Up DC/DC Converter	92% Efficiency V <sub>IN</sub> : 1.6V to 4.3V, V <sub>OUT(MAX)</sub> = 5V, I <sub>SD</sub> < 1μA, SOT-23 Package
LTC3428	500mA I <sub>SW</sub> , 1.25MHz/2.5MHz, Synchronous Step-Up DC/DC Converters with Output Disconnect	92% Efficiency V <sub>IN</sub> : 1.8V to 5V, V <sub>OUT(MAX)</sub> = 5.25V, I <sub>SD</sub> < 1μA, 2mm × 2mm DFN Package
LTC3429	600mA I <sub>SW</sub> , 500kHz, Synchronous Step-Up DC/DC Converter with Output Disconnect and Soft-Start	96% Efficiency V <sub>IN</sub> : 0.5V to 4.4V, V <sub>OUT(MAX)</sub> = 5V, I <sub>Q</sub> = 20μA/300μA, I <sub>SD</sub> < 1μA, ThinSOT Package
LTC3458	1.4A I <sub>SW</sub> , 1.5MHz, Synchronous Step-Up DC/DC Converter/Output Disconnect/Burst Mode Operation	93% Efficiency V <sub>IN</sub> : 1.5V to 6V, V <sub>OUT(MAX)</sub> = 7.5V, I <sub>Q</sub> = 15μA, I <sub>SD</sub> < 1μA, DFN12 Package
LTC3458L	1.7A I <sub>SW</sub> , 1.5MHz, Synchronous Step-Up DC/DC Converter with Output Disconnect, Automatic Burst Mode® Operation	94% Efficiency V <sub>OUT(MAX)</sub> = 6V, I <sub>Q</sub> = 12μA, DFN12 Package
LTC3459	70mA I <sub>SW</sub> , 10V Micropower Synchronous Boost Converter/Output Disconnect/Burst Mode Operation	V <sub>IN</sub> : 1.5V to 5.5V, V <sub>OUT(MAX)</sub> = 10V, I <sub>Q</sub> = 10μA, I <sub>SD</sub> < 1μA, ThinSOT Package
LTC3525-3.3 LTC3525-5	400mA Micropower Synchronous Step-Up DC/DC Converter with Output Disconnect	95% Efficiency V <sub>IN</sub> : 1V to 4.5V, V <sub>OUT(MAX)</sub> = 3.3V or 5V, I <sub>Q</sub> = 7μA, I <sub>SD</sub> < 1μA, SC-70 Package

ThinSOT is a trademark of Linear Technology Corporation. Burst Mode is a registered trademark of Linear Technology Corporation.