

# LTC3121EDE

## High Efficiency 15V 1.5A Synchronous Step-Up Converter

### DESCRIPTION

Demonstration circuit 2372A is a 5.5V input, 12V output at 400mA DC/DC power supply featuring the [LTC®3121](#). The IC includes internal high and low side 1.5A switches and features selectable PWM or Burst Mode® operation for high efficiency at low output current. The board operates from an input voltage as low as 1.8V and continues to operate down to 500mV once started. The output is fixed at 12V although other voltages between 2.2V and 15V can be selected by resistor changes.

The IC includes soft-start and input current limit, adjustable switching frequency with the ability to synchronize to an external clock, and output overvoltage protection with output disconnect.

Included on the board are jumpers for ON/OFF and operating MODE, PWM or BURST. Terminals are included for connecting  $V_{IN}$  and  $V_{OUT}$  as well as ON/OFF and SYNC.

The LTC3121 data sheet gives a complete description of the IC operation and application information. The data sheet must be read in conjunction with this quick start guide.

**Design files for this circuit board are available at <http://www.linear.com/demo/DC2372A>**

LT, LT, LTC, LTM, Linear Technology, the Linear logo and Burst Mode are registered trademarks of Linear Technology Corporation. All other trademarks are the property of their respective owners.

### PERFORMANCE SUMMARY Specifications are at $T_A = 25^\circ\text{C}$

PARAMETER	CONDITION	VALUE
Input Voltage Range		1.8V to 5.5V
Output Voltage	$V_{IN} = 5V, V_{OUT} \text{ Load} = 400\text{mA}$	12V $\pm 3\%$
Output Current	$V_{IN} = 5V, V_{OUT} = 12V$	400mA
Output Voltage Ripple (PWM Mode)	$V_{IN} = 5V, V_{OUT} = 12V, V_{OUT} \text{ Load} = 400\text{mA}$	40mV <sub>p-p</sub>
Output Voltage Ripple (Burst Mode Operation)	$V_{IN} = 5V, V_{OUT} = 12V, V_{OUT} \text{ Load} = 50\text{mA}$	200mV <sub>p-p</sub>
Switching Frequency		1MHz $\pm 15\%$

## QUICK START PROCEDURE

This Demonstration circuit 2372A can be evaluated using the setup shown in Figure 1.

1. Connect voltmeters to  $V_{IN}$  and  $V_{OUT}$ , select upper positions for jumper JP1 (ON) and JP2 (PWM).
2. With input power supply set for 0V, connect the supply to  $V_{IN}$  and GND terminals.
3. Slowly increase the input power supply to 1.8V. Observe output voltage and verify that it meets the specifications in the Performance Summary table.
4. Connect a suitable load resistor or active load to the output terminals and verify that it meets specifications in the Performance Summary table.
5. Use a scope to monitor the output voltage ripple in both PWM mode and Burst Mode operation by moving the mode jumper JP2 to the appropriate position. See Figure 4 for correct method for evaluating output ripple.
6. Note: If jumper JP2 is set for Burst Mode operation, maximum output current is limited to approximately 100mA at 5V<sub>IN</sub>.

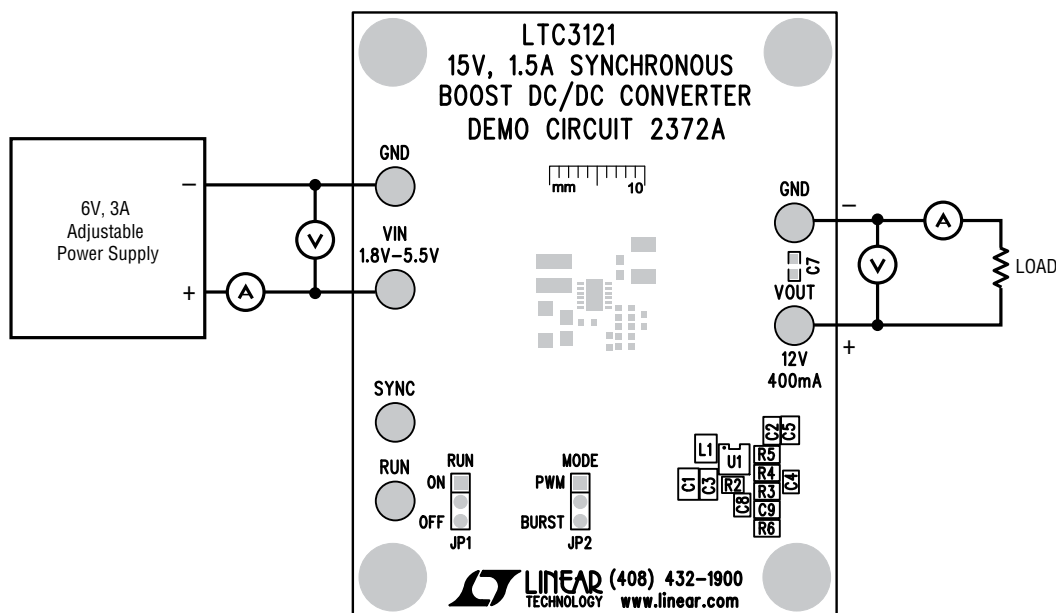
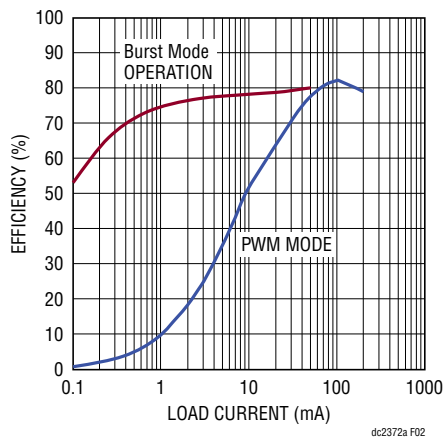
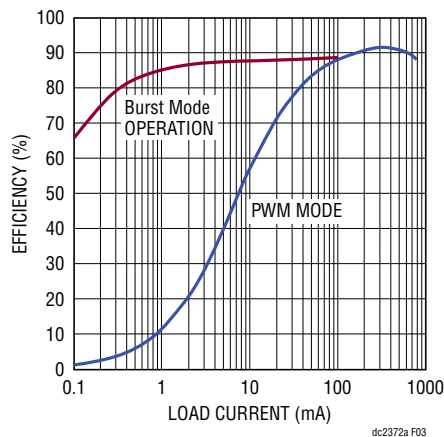

Figure 1. Proper Measurement Equipment Setup

**QUICK START PROCEDURE**



**Figure 2. Efficiency  $V_{IN} = 2V$**



**Figure 3. Efficiency  $V_{IN} = 5V$**

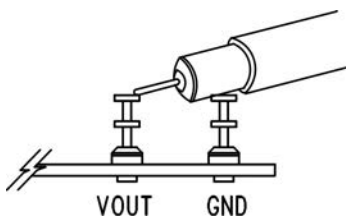

**Figure 4. Measuring Output Voltage Ripple**

# DEMO MANUAL DC2372A

## PARTS LIST

ITEM	QTY	REFERENCE	PART DESCRIPTION	MANUFACTURER/PART NUMBER
1	1	C1	CAP 10 $\mu$ F X5R 10V 10%1206	TDK, C3216X5R1A106K
2	1	C2	CAP 0.10 $\mu$ F X7R 50V 10% 0603	TDK, CGA3E2X7R1H104K080AA
3	1	C3	CAP 4.7 $\mu$ F X5R 25V 10% 0805	TDK,C2012X5R1E475K085AC
4	0	C4	CAP 0402 OPT	OPT
5	1	C5	CAP 22 $\mu$ F 25V X5R 10% 1210	MURATA, GRM32ER61E226KE15L
6	1	C7	CAP 1 $\mu$ F X7R 25V 10% 0603	TDK, CGA3E1X7R1E105K080AC
7	1	C8	CAP 1nF 50V X7R 10% 0402	AVX, 04025C102KAT2A
8	1	C9	CAP 10pF COG 25V 5% 0402	AVX, 04023A100JAT2A
9	6	E1-E6	TEST POINT, TURRET, 0.094 MTG. HOLE	MILL-MAX, 2501-2-00-80-00-00-07-0
10	2	JP2, JP1	CONN, HEADER, 1 $\times$ 3, 2mm	SAMTEC, TMM-103-02-L-S
11	2	XJP1, XJP2	SHUNT, 2mm	SAMTEC, 2SN-BK-G
12	1	L1	IND, PWR 6.8 $\mu$ H, 20%, XAL40xx Series	COILCRAFT, XAL4030-682ME
13	1	R1	RES, 1M $\Omega$ 1/10W 1% 0402	PANASONIC, ERJ2RKF1004X
14	1	R2	RES, 57.6k $\Omega$ 1/10W 1% 0402	PANASONIC, ERJ2RKF5762X
15	0	R3	RES,0402 OPT	OPT
16	1	R4	RES 1.02M $\Omega$ 1/10W 1% 0402	VISHAY, CRCW04021M02FKED
17	1	R5	RES, 113k $\Omega$ 1/10W 1% 0402	PANASONIC, ERJ2RKF1133X
18	1	R6	RES, 82.5k $\Omega$ 1/10W 1% 0402	PANASONIC, ERJ2RKF8252X
19	1	U1	IC, LTC3121EDE	LINEAR TECH, LTC3121EDE
20	4	STAND OFF	STAND-OFF, NYLON 0.500"	KEYSTONE, 8832 (SNAP ON)
21	1		FAB, PRINTED CIRCUIT BOARD	LINEAR TECH, DEMO CIRCUIT 2372A
22	2		STENCILS, TOP & BOTTOM	LINEAR TECH, DEMO CIRCUIT 2372A

**SCHEMATIC DIAGRAM**

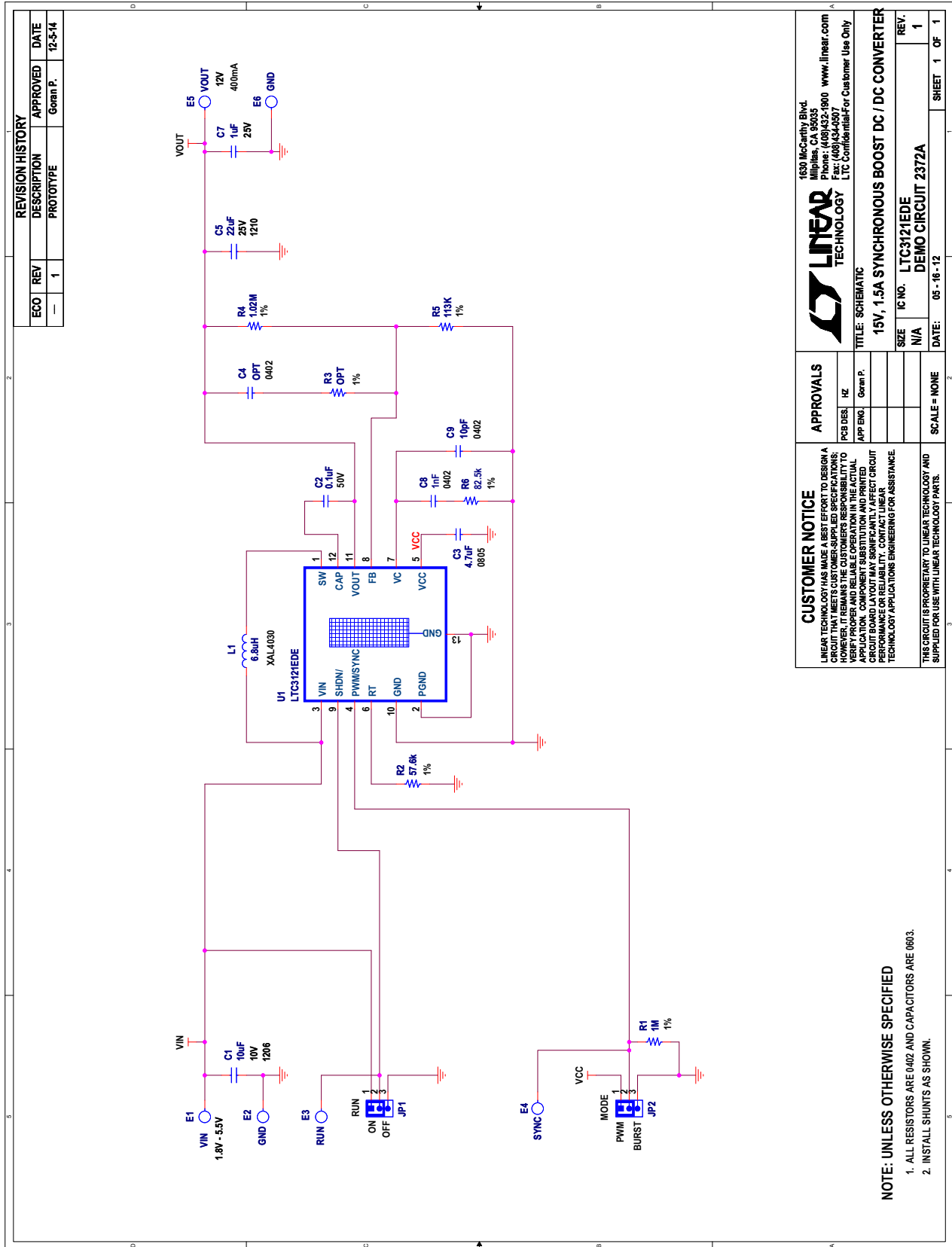

dc2372af

# DEMO MANUAL DC2372A

---

## DEMONSTRATION BOARD IMPORTANT NOTICE

Linear Technology Corporation (LTC) provides the enclosed product(s) under the following **AS IS** conditions:

This demonstration board (DEMO BOARD) kit being sold or provided by Linear Technology is intended for use for **ENGINEERING DEVELOPMENT OR EVALUATION PURPOSES ONLY** and is not provided by LTC for commercial use. As such, the DEMO BOARD herein may not be complete in terms of required design-, marketing-, and/or manufacturing-related protective considerations, including but not limited to product safety measures typically found in finished commercial goods. As a prototype, this product does not fall within the scope of the European Union directive on electromagnetic compatibility and therefore may or may not meet the technical requirements of the directive, or other regulations.

If this evaluation kit does not meet the specifications recited in the DEMO BOARD manual the kit may be returned within 30 days from the date of delivery for a full refund. **THE FOREGOING WARRANTY IS THE EXCLUSIVE WARRANTY MADE BY THE SELLER TO BUYER AND IS IN LIEU OF ALL OTHER WARRANTIES, EXPRESSED, IMPLIED, OR STATUTORY, INCLUDING ANY WARRANTY OF MERCHANTABILITY OR FITNESS FOR ANY PARTICULAR PURPOSE. EXCEPT TO THE EXTENT OF THIS INDEMNITY, NEITHER PARTY SHALL BE LIABLE TO THE OTHER FOR ANY INDIRECT, SPECIAL, INCIDENTAL, OR CONSEQUENTIAL DAMAGES.**

The user assumes all responsibility and liability for proper and safe handling of the goods. Further, the user releases LTC from all claims arising from the handling or use of the goods. Due to the open construction of the product, it is the user's responsibility to take any and all appropriate precautions with regard to electrostatic discharge. Also be aware that the products herein may not be regulatory compliant or agency certified (FCC, UL, CE, etc.).

No License is granted under any patent right or other intellectual property whatsoever. **LTC assumes no liability for applications assistance, customer product design, software performance, or infringement of patents or any other intellectual property rights of any kind.**

LTC currently services a variety of customers for products around the world, and therefore this transaction **is not exclusive**.

**Please read the DEMO BOARD manual prior to handling the product.** Persons handling this product must have electronics training and observe good laboratory practice standards. **Common sense is encouraged.**

This notice contains important safety information about temperatures and voltages. For further safety concerns, please contact a LTC application engineer.

Mailing Address:

Linear Technology  
1630 McCarthy Blvd.  
Milpitas, CA 95035

Copyright © 2004, Linear Technology Corporation