

Push Button On/Off Controller with μ P Interrupt

FEATURES

- Adjustable Power On/Off Timers
- Low Supply Current: 6 μ A
- Wide Operating Voltage Range: 2.7V to 26.4V
- Low Leakage EN Output (LTC2954-1) Allows DC/DC Converter Control
- High Voltage $\overline{\text{EN}}$ Output (LTC2954-2) Allows Circuit Breaker Control
- Simple Interface Allows Graceful μ P Shut Down
- High Input Voltage PB Pin with Internal Pull Up Resistor
- $\pm 10\text{kV}$ ESD HBM on $\overline{\text{PB}}$ Input
- Accurate 0.6V Threshold on KILL Comparator Input
- 8-Pin 3mm \times 2mm DFN and ThinSOT™ Packages

APPLICATIONS

- Push Button Power Path Control
- Portable Instrumentation Meters
- Blade Servers
- Portable Customer Service PDA
- Desktop and Notebook Computers

DESCRIPTION

The LTC[®]2954 is a push button On/Off controller that manages system power via a push button interface. An enable output toggles system power while an interrupt output provides debounced push button status. The interrupt output can be used in menu driven applications to request a system power down. A power kill input allows a microprocessor or system to reset the enable output, effectively powering down the system. Independently adjustable On and Off timers allow dependable push button control of the enable output and resistance to accidental toggling of system power.

The LTC2954 operates over a wide 2.7V to 26.4V input voltage range to accommodate a wide variety of input power supplies. Very low quiescent current (6 μ A typical) makes the LTC2954 ideally suited for battery powered applications. Two versions of the part are available to accommodate either positive or negative enable polarities.

LT, LT, LTC and LTM are registered trademarks of Linear Technology Corporation. ThinSOT is a trademark of Linear Technology Corporation. All other trademarks are the property of their respective owners.

TYPICAL APPLICATION

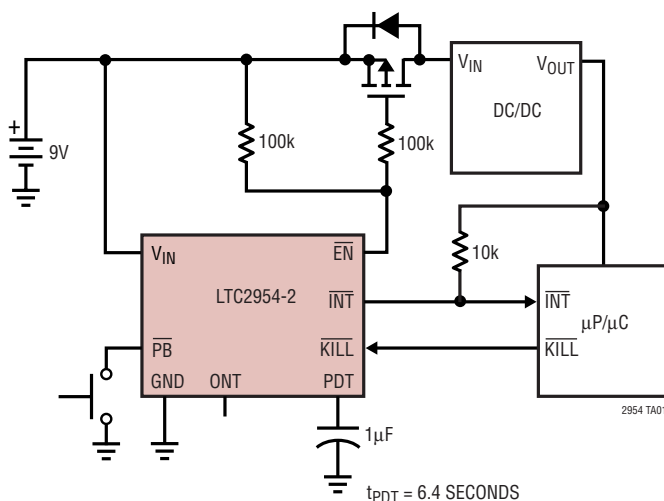

Push Button On/Off with Interrupt

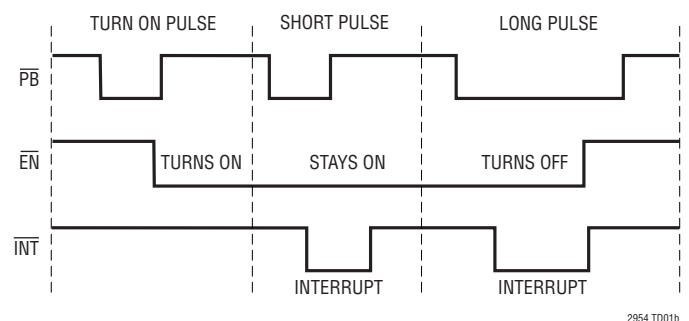

2954 TD01b

ABSOLUTE MAXIMUM RATINGS

(Note 1)

Supply Voltage (V_{IN})	-0.3V to 33V	Operating Temperature Range	
Input Voltages			LTC2954C-1 0°C to 70°C
\overline{PB}	-6V to 33V	LTC2954C-2 0°C to 70°C
ONT	-0.3V to 2.7V	LTC2954I-1 -40°C to 85°C
PDT	-0.3V to 2.7V	LTC2954I-2 -40°C to 85°C
KILL	-0.3V to 7V	Storage Temperature Range	
Output Voltages			DFN Package -65°C to 125°C
\overline{INT}	-0.3V to 10V	TSOT-23 -65°C to 150°C
$\overline{EN/\overline{EN}}$	-0.3V to 33V	Lead Temperature (Soldering, 10 sec) 300°C

PACKAGE/ORDER INFORMATION

<p>DDB PACKAGE 8-LEAD (3mm × 2mm) PLASTIC DFN $T_{JMAX} = 125^{\circ}C$, $\theta_{JA} = 165^{\circ}C/W$ EXPOSED PAD (PIN 9) UNCONNECTED</p>		<p>TS8 PACKAGE 8-LEAD PLASTIC TSOT-23 $T_{JMAX} = 125^{\circ}C$, $\theta_{JA} = 140^{\circ}C/W$</p>	
ORDER PART NUMBER	DDB PART MARKING*	ORDER PART NUMBER	TS8 PART MARKING*
LTC2954CDDDB-1	LCJG	LTC2954CTS8-1	LTCJH
LTC2954CDDDB-2	LCNJ	LTC2954CTS8-2	LTCNK
LTC2954IDDB-1	LCJG	LTC2954ITS8-1	LTCJH
LTC2954IDDB-2	LCNJ	LTC2954ITS8-2	LTCNK

Order Options Tape and Reel: Add #TR Lead Free: Add #PBF Lead Free Tape and Reel: Add #TRPBF
Lead Free Part Marking: <http://www.linear.com/leadfree/>

Consult LTC Marketing for parts specified with wider operating temperature ranges. *The temperature grade is identified by a label on the shipping container.

ELECTRICAL CHARACTERISTICS

The ● denotes the specifications which apply over the full operating temperature range, otherwise specifications are at $T_A = 25^{\circ}C$. $V_{IN} = 2.7V$ to $26.4V$, unless otherwise noted. (Note 2)

SYMBOL	PARAMETER	CONDITIONS	MIN	TYP	MAX	UNITS
V_{IN}	Supply Voltage Range	Steady State Operation	● 2.7		26.4	V
I_{IN}	V_{IN} Supply Current	System Power On, $V_{IN} = 2.7V$ to $24V$	●	6	12	μA
V_{UVL}	V_{IN} Undervoltage Lockout	V_{IN} Falling	● 2.2	2.3	2.5	V
$V_{UVL(HYST)}$	V_{IN} Undervoltage Lockout Hysteresis			50	400	700 mV
Push Button, Enable (\overline{PB}, $\overline{EN/\overline{EN}}$)						
$V_{\overline{PB}(MIN, MAX)}$	\overline{PB} Voltage Range	Single-Ended	● -1		26.4	V

ELECTRICAL CHARACTERISTICS

The ● denotes the specifications which apply over the full operating temperature range, otherwise specifications are at $T_A = 25^\circ\text{C}$. $V_{IN} = 2.7\text{V}$ to 26.4V , unless otherwise noted. (Note 2)

SYMBOL	PARAMETER	CONDITIONS	MIN	TYP	MAX	UNITS	
$I_{\overline{PB}}$	\overline{PB} Input Current	$2.5\text{V} < V_{\overline{PB}} < 26.4\text{V}$	●		± 1	μA	
		$V_{\overline{PB}} = 1\text{V}$	●	-1	-6	-12	μA
		$V_{\overline{PB}} = 0.6\text{V}$	●	-3	-9	-15	μA
$V_{\overline{PB}}(\text{VTH})$	\overline{PB} Input Threshold	\overline{PB} Falling	●	0.6	0.8	1	V
$V_{\overline{PB}}(\text{VOC})$	\overline{PB} Open Circuit Voltage	$I_{\overline{PB}} = -1\mu\text{A}$		1	1.6	2	V
$t_{\text{EN, Lock Out}}$	EN/ $\overline{\text{EN}}$ Lock Out Time (Note 5)	Enable Released \rightarrow Enable Asserted	●	200	256	325	ms
$I_{\text{EN}}(\text{LKG})$	EN/ $\overline{\text{EN}}$ Leakage Current	$V_{\text{EN}/\overline{\text{EN}}} = 1\text{V}$, Sink Current Off	●		± 0.1	μA	
		$V_{\text{EN}/\overline{\text{EN}}} = 26.4\text{V}$, Sink Current Off	●		± 1	μA	
$V_{\text{EN}}(\text{VOL})$	EN/ $\overline{\text{EN}}$ Voltage Output Low	$I_{\text{EN}/\overline{\text{EN}}} = 500\mu\text{A}$	●	0.11	0.4	V	

Power On Timing Pin (ONT)

$I_{\text{ONT}}(\text{PU})$	ONT Pull Up Current	$V_{\text{ONT}} = 0\text{V}$	●	-2.4	-3	-3.6	μA
$I_{\text{ONT}}(\text{PD})$	ONT Pull Down Current	$V_{\text{ONT}} = 1.3\text{V}$	●	2.4	3	3.6	μA
$t_{\text{DB, ON}}$	Internal Turn On Debounce Time	ONT Pin Float, \overline{PB} Falling \rightarrow Enable Asserted	●	26	32	41	ms
t_{ONT}	Additional Adjustable Turn On Time	$C_{\text{ONT}} = 1500\text{pF}$	●	9	11.5	13.5	ms

Power Down Timing Pin (PDT)

$I_{\text{PDT}}(\text{PU})$	PDT Pull Up Current	$V_{\text{PDT}} = 0\text{V}$	●	-2.4	-3	-3.6	μA
$I_{\text{PDT}}(\text{PD})$	PDT Pull Down Current	$V_{\text{PDT}} = 1.3\text{V}$	●	2.4	3	3.6	μA
$t_{\text{DB, OFF}}$	Turn Off Interrupt Debounce Time	\overline{PB} Falling \rightarrow $\overline{\text{INT}}$ Falling	●	26	32	41	ms
$t_{\text{PD, Min}}$	Internal \overline{PB} Power Down Debounce Time (Note 4)	PDT Pin Float, \overline{PB} Falling \rightarrow Enable Released	●	52	64	82	ms
t_{PDT}	Additional Adjustable \overline{PB} Power Down Debounce Time	$C_{\text{PDT}} = 1500\text{pF}$	●	9	11.5	13.5	ms
$t_{\overline{\text{INT}}, \text{Min}}$	Minimum $\overline{\text{INT}}$ Pulse Width	$\overline{\text{INT}}$ Asserted \rightarrow $\overline{\text{INT}}$ Released	●	26	32	41	ms
$t_{\overline{\text{INT}}, \text{Max}}$	Maximum $\overline{\text{INT}}$ Pulse Width	$C_{\text{PDT}} = 1500\text{pF}$, $\overline{\text{INT}}$ Asserted \rightarrow $\overline{\text{INT}}$ Released	●	35	43.5	54.5	ms

μP Handshake Pins ($\overline{\text{INT}}$, $\overline{\text{KILL}}$)

$I_{\overline{\text{INT}}}(\text{LKG})$	$\overline{\text{INT}}$ Leakage Current	$V_{\overline{\text{INT}}} = 3\text{V}$	●		± 1	μA	
$V_{\overline{\text{INT}}}(\text{VOL})$	$\overline{\text{INT}}$ Output Voltage Low	$I_{\overline{\text{INT}}} = 3\text{mA}$	●		0.11	0.4	V
$V_{\overline{\text{KILL}}}(\text{TH})$	$\overline{\text{KILL}}$ Input Threshold Voltage	$\overline{\text{KILL}}$ Falling	●	0.57	0.6	0.63	V
$V_{\overline{\text{KILL}}}(\text{HYST})$	$\overline{\text{KILL}}$ Input Threshold Hysteresis		●	10	30	50	mV
$I_{\overline{\text{KILL}}}(\text{LKG})$	$\overline{\text{KILL}}$ Leakage Current	$V_{\overline{\text{KILL}}} = 0.6\text{V}$	●		± 0.1	μA	
$t_{\overline{\text{KILL}}}(\text{PW})$	$\overline{\text{KILL}}$ Minimum Pulse Width		●	30			μs
$t_{\overline{\text{KILL}}}(\text{PD})$	$\overline{\text{KILL}}$ Propagation Delay	$\overline{\text{KILL}}$ Falling \rightarrow Enable Released	●			30	μs
$t_{\overline{\text{KILL}}, \text{On Blank}}$	$\overline{\text{KILL}}$ Turn On Blanking (Note 3)	$\overline{\text{KILL}} = \text{Low}$, Enable Asserted \rightarrow Enable Released	●	400	512	650	ms

Note 1: Stresses beyond those listed under Absolute Maximum Ratings may cause permanent damage to the device. Exposure to any Absolute Maximum Rating condition for extended periods may affect device reliability and lifetime.

Note 2: All currents into pins are positive; all voltages are referenced to GND unless otherwise noted.

Note 3: The $\overline{\text{KILL}}$ turn on blanking timer period is the waiting period immediately after the enable output is asserted. This blanking time allows sufficient time for the DC/DC converter and the μP to perform power up tasks. The $\overline{\text{KILL}}$ and \overline{PB} inputs are ignored during this period. If $\overline{\text{KILL}}$ remains

low at the end of this time period, the enable output is released, thus turning off system power. This time delay does not include $t_{\text{DB, ON}}$ or t_{ONT} .

Note 4: To manually force an immediate release of the EN/ $\overline{\text{EN}}$ pin, the push button input must be held low for at least $t_{\text{PD, Min}}$ (internal default power down timer) + t_{PDT} (adjustable by placing external capacitor at PDT pin).

Note 5: The enable lock out time is designed to allow an application to properly power down such that the next power up sequence starts from a consistent powered down configuration. \overline{PB} is ignored during this lock out time. This time delay does not include $t_{\text{DB, ON}}$ or t_{ONT} .

TYPICAL PERFORMANCE CHARACTERISTICS

Supply Current vs Temperature

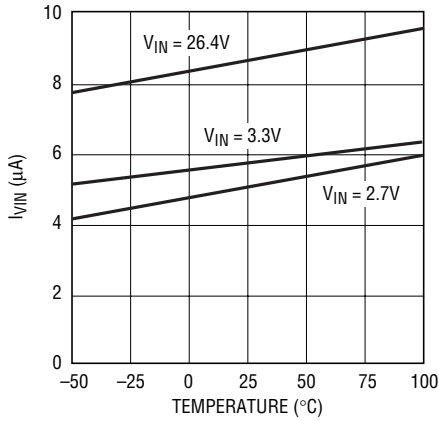

2954 G01

Supply Current vs Supply Voltage

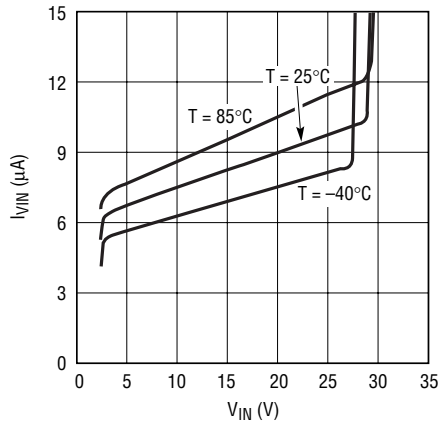

2954 G02

Internal Default Turn On Debounce Time ($t_{DB, ON}$) vs V_{IN}

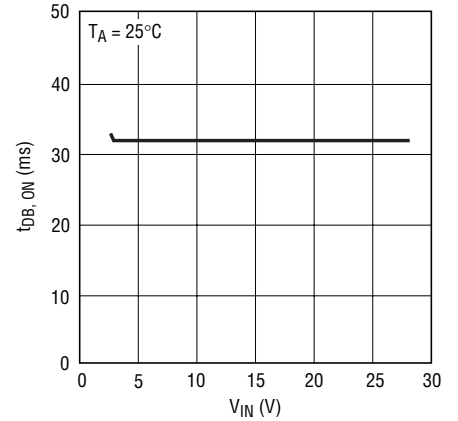

2954 G03

Turn On Debounce Time ($t_{DB, ON} + t_{ONT}$) vs ONT External Capacitance

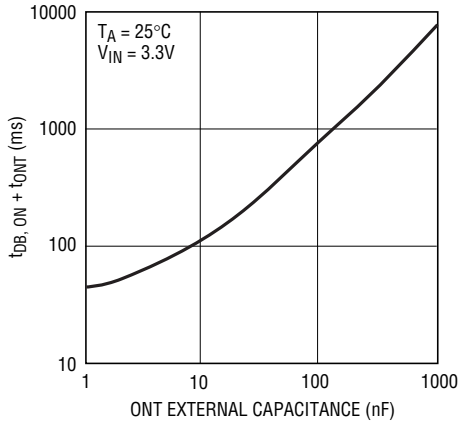

2954 G04

ONT Pull-Up Current vs Temperature

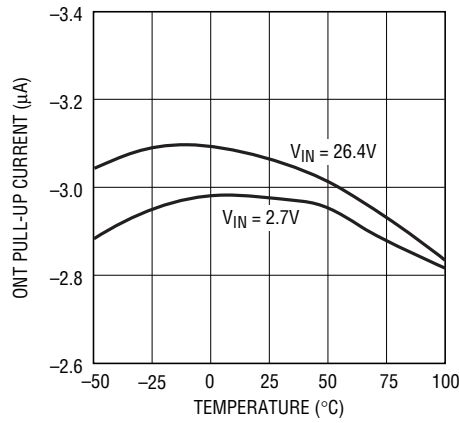

2954 G05

Turn Off Debounce Time ($t_{DB, OFF}$) vs V_{IN}

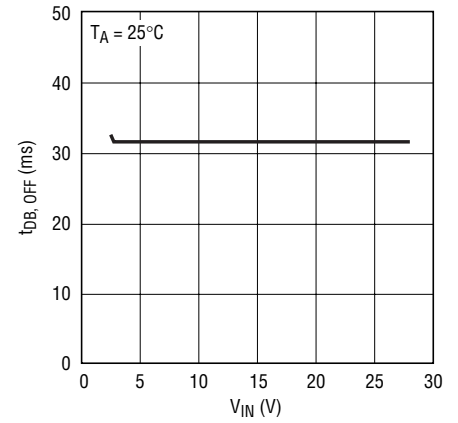

2954 G06

Internal Default \overline{PB} Power Down Debounce Time ($t_{PD, MIN}$) vs V_{IN}

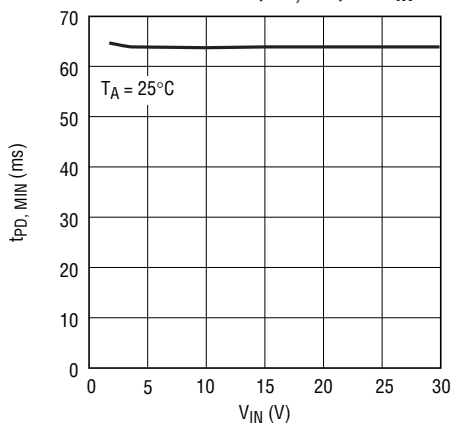

2954 G14

\overline{PB} Power Down Debounce Time ($t_{PD, MIN} + t_{PDT}$) vs PDT External Capacitance

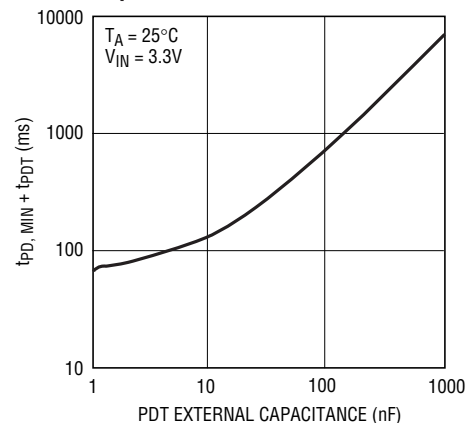

2954 G07

PDT Pull-Up Current vs Temperature

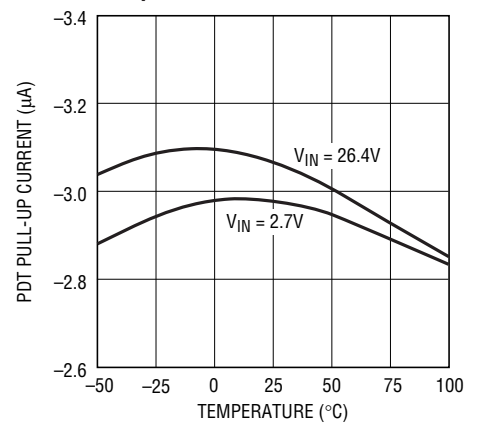

2954 G08

TYPICAL PERFORMANCE CHARACTERISTICS

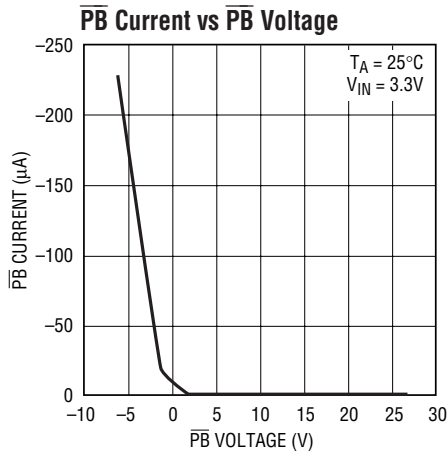

2954 G09

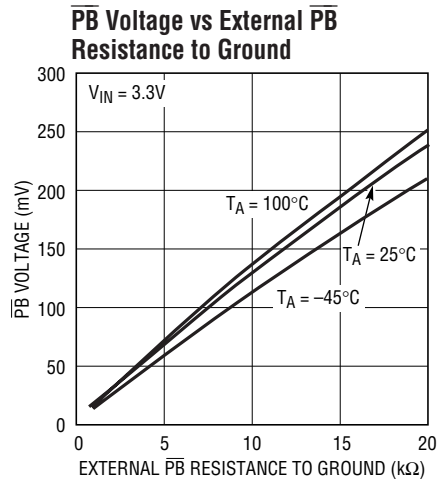

2954 G10

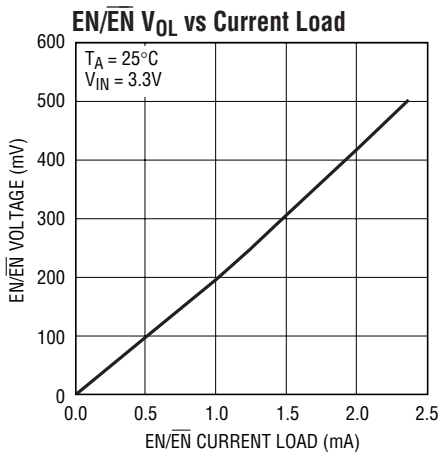

2954 G11

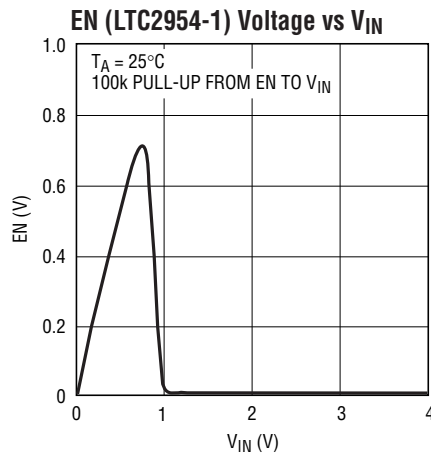

2954 G12

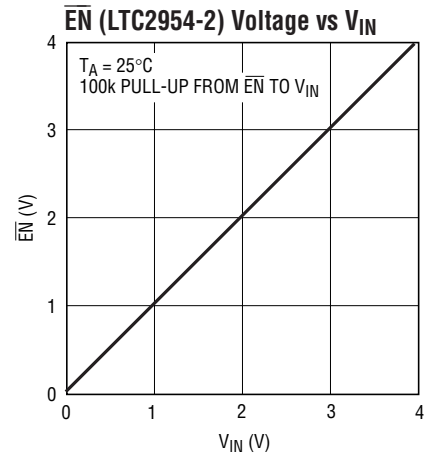

2954 G13

PIN FUNCTIONS (TSOT-23/DFN)

V_{IN} (Pin 1/Pin 4): Power Supply Input: 2.7V to 26.4V.

$\overline{\text{PB}}$ (Pin 2/Pin 3): Push Button Input. Connecting $\overline{\text{PB}}$ to ground through a momentary switch provides On/Off control via the EN/ $\overline{\text{EN}}$ and $\overline{\text{INT}}$ outputs. An internal 100k pull-up resistor connects to an internal 1.9V bias voltage. The rugged $\overline{\text{PB}}$ input withstands $\pm 10\text{kV}$ ESD HBM and can be pulled up to 26.4V externally without consuming extra current.

ONT (Pin 3/Pin 2): Turn On Time Input. Placing an external capacitor to ground determines the additional time (6.4 seconds/ μF) the $\overline{\text{PB}}$ pin must be held low before the enable output is asserted. Floating this pin results in a default turn on debounce time of 32ms.

GND (Pin 4/Pin 1): Device Ground.

$\overline{\text{INT}}$ (Pin 5/Pin 8): Open Drain Interrupt Output. After a push button turn off event is detected ($t_{\text{DB,OFF}}$), the LTC2954 interrupts the system (μP) by asserting the $\overline{\text{INT}}$ pin low. The μP would perform power down and housekeeping tasks and then assert the $\overline{\text{KILL}}$ pin low, thus releasing the enable output. The $\overline{\text{INT}}$ pulse width is a minimum of 32ms and stays low as long as $\overline{\text{PB}}$ is asserted. If $\overline{\text{PB}}$ is asserted for longer than $t_{\text{PD,Min}} + t_{\text{PDT}}$, the $\overline{\text{INT}}$ and EN/ $\overline{\text{EN}}$ outputs are immediately released.

EN (LTC2954-1, Pin 6/Pin 7): Open Drain Enable Output. This pin is intended to enable system power. EN is asserted high after a valid $\overline{\text{PB}}$ turn on event ($t_{\text{DB,ON}} + t_{\text{ONT}}$). EN is

released low if: a) $\overline{\text{KILL}}$ is not driven high (by μP) within 512ms of the initial valid $\overline{\text{PB}}$ power turn-on event, b) $\overline{\text{KILL}}$ is driven low during normal operation, c) $\overline{\text{PB}}$ is pressed and held low ($t_{\text{PD,Min}} + t_{\text{PDT}}$) during normal operation. The operating range for this low leakage pin is 0V to 26.4V.

$\overline{\text{EN}}$ (LTC2954-2, Pin 6/Pin 7): Open Drain Enable Bar Output. This pin is intended to enable system power. $\overline{\text{EN}}$ is asserted low after a valid $\overline{\text{PB}}$ turn-on event ($t_{\text{DB,ON}} + t_{\text{ONT}}$). $\overline{\text{EN}}$ releases high if: a) $\overline{\text{KILL}}$ is not driven high (by μP) within 512ms of the initial valid $\overline{\text{PB}}$ power turn-on event, b) $\overline{\text{KILL}}$ is driven low during normal operation, c) $\overline{\text{PB}}$ is pressed and held low ($t_{\text{PD,Min}} + t_{\text{PDT}}$) during normal operation. The operating range of this pin is 0V to 26.4V.

PDT (Pin 7/Pin 6): Power Down Time Input. A capacitor to ground determines the additional time (6.4 seconds/ μF) that the push button must be held low before immediately releasing the EN/ $\overline{\text{EN}}$ and $\overline{\text{INT}}$ outputs. Floating this pin results in a push button power down time of 64ms.

$\overline{\text{KILL}}$ (Pin 8/Pin 5): Kill Input. Forcing $\overline{\text{KILL}}$ low releases the enable output. During system turn on, this pin is blanked by a 512ms internal timer ($t_{\text{KILL,ON BLANK}}$) to allow the system to pull $\overline{\text{KILL}}$ high. This pin has an accurate 0.6V threshold and can be used as a voltage monitor input.

Exposed Pad (Pin 9 DFN Only): Exposed Pad may be left open or connected to device ground.

BLOCK DIAGRAM

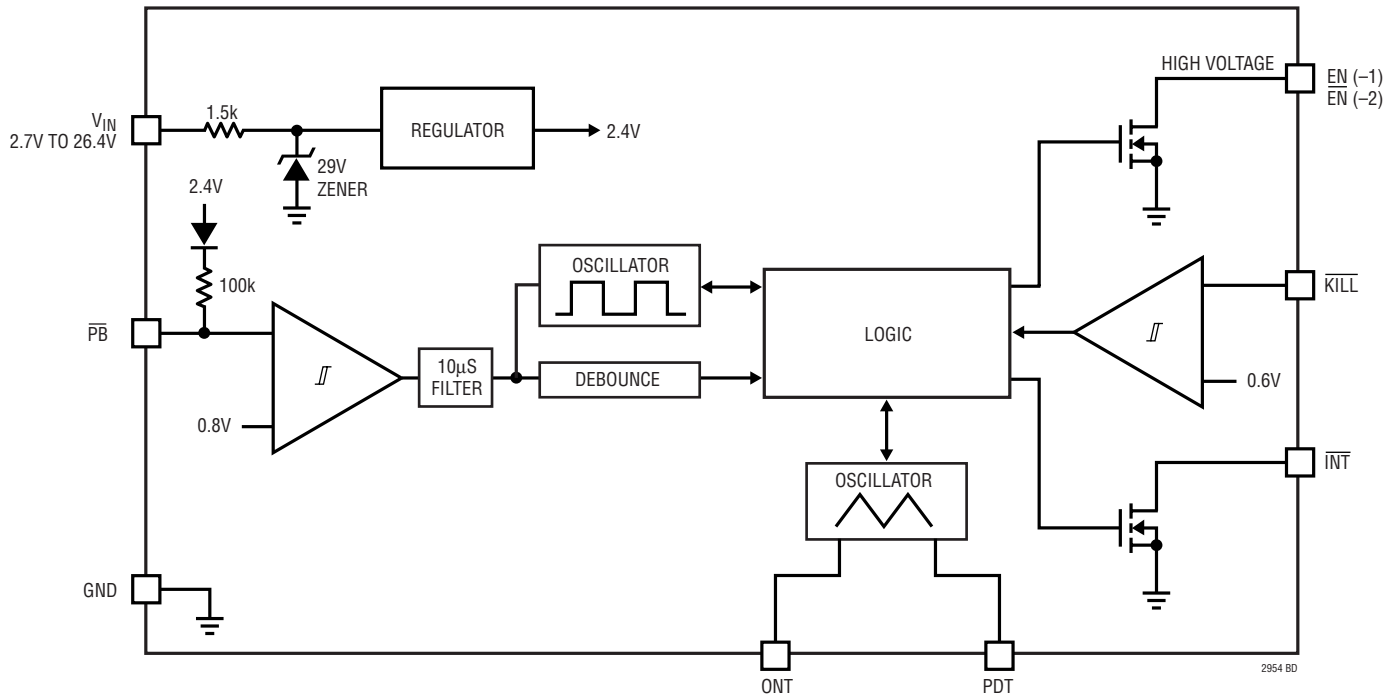

TIMING DIAGRAMS

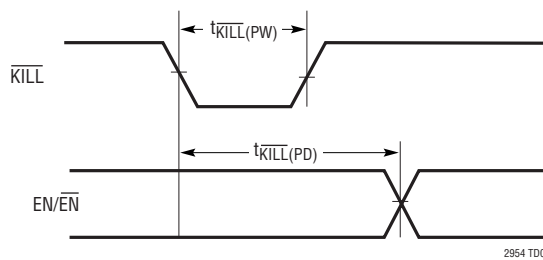

TIMING DIAGRAMS

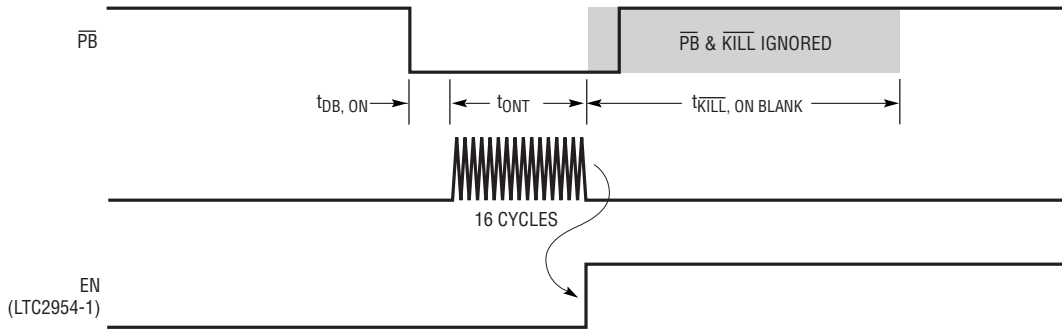

Power On Timing

2954 TD02

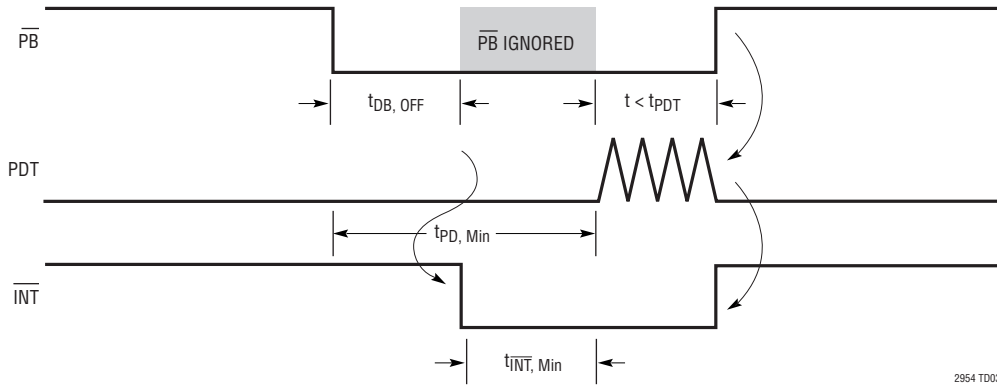

Off Interrupt Timing, \overline{PB} Pressed and Released, Enable Remains Active

2954 TD03

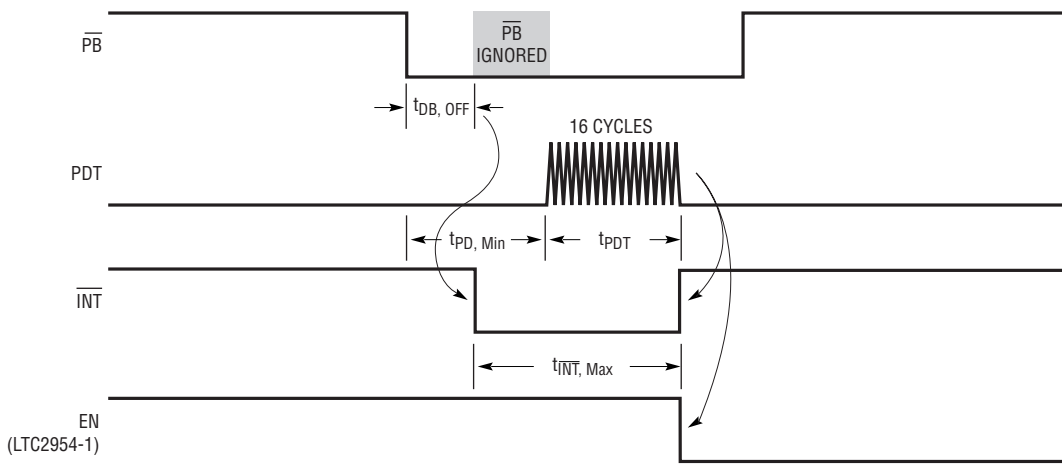

Forced Off, Power Down Timing, \overline{PB} Pressed and Held Low for $t > (t_{PD, Min} + t_{PDT})$

2954 TD04

APPLICATIONS INFORMATION

Description

The LTC2954 is a push button On/Off controller that provides control of system power via a push button interface. An enable output toggles system power while an interrupt output provides debounced push button status. The interrupt output can be used in menu driven applications to request a system power down. A power kill input allows a microprocessor or system to release the enable output, effectively powering down the system. Independently adjustable On and Off timers allow dependable push button control of the enable output and resistance to accidental toggling of system power.

The length of time the push button input (\overline{PB}) must be held low in order to toggle the enable (EN/\overline{EN}) output on and off is independently adjustable with external capacitors at the ONT/PDT pins, respectively. During normal operation, the interrupt output (\overline{INT}) is asserted 32ms after \overline{PB} goes low. \overline{INT} then tracks \overline{PB} until either \overline{PB} or EN/\overline{EN} is released. See Timing Diagrams on page 8.

The \overline{KILL} input is used to immediately release the enable output. During a normal power down sequence, \overline{INT} requests a system power down. The μP then performs its housekeeping tasks and then sets \overline{KILL} low. If the μP fails to set \overline{KILL} low, the user can force a system shutdown by pressing and holding the push button until the PDT timer expires.

Turn On

When power is first applied to the LTC2954, the part initializes the output pins. Any DC/DC converters connected to the EN/\overline{EN} pin will therefore be held off. To assert the enable output, \overline{PB} must be held low for a minimum of 32ms ($t_{DB, ON}$). The LTC2954 provides additional turn on debounce time (t_{ONT}) via an optional capacitor connected to the ONT pin. The following equation describes the additional time that \overline{PB} must be held low before asserting the enable output. C_{ONT} is the ONT external capacitor (μF):

$$C_{ONT} = 1.56 \times 10^{-4} [\mu F/ms] \cdot (t_{ONT} - 1ms)$$

Once the enable output is asserted, any DC/DC converters connected to this pin are turned on. The \overline{KILL} input from the μP is ignored during a succeeding 512ms blanking time ($t_{\overline{KILL}, ON BLANK}$). This blanking time represents the

maximum time required to power up the DC/DC converter and the μP . If \overline{KILL} is not brought high during this 512ms time window, the enable output is released. The assumption is that 512ms is sufficient time for the system to power up.

Turn Off

To initiate a power down sequence, assert the \overline{INT} output low by pressing the push button for a minimum of 32ms ($t_{DB, OFF}$). The interrupt signal serves as a power down request to the μP . The μP would then perform power down and housekeeping tasks and assert \overline{KILL} low when done. This in turn releases the enable output, thus shutting off system power.

Adjustable Power Down Timer

The LTC2954 provides a failsafe feature that allows the user to turn off system power (via \overline{PB}) under system fault conditions. For cases when the μP fails to respond to the interrupt signal, the user can force an immediate power down by pressing and holding down the push button. The length of time that \overline{PB} must be held low is given by a fixed internal 64ms delay ($t_{PD, Min}$) plus an adjustable power down timer delay (t_{PDT} , see timing diagram on page 8). The adjustable delay is set by placing an optional external capacitor on the PDT pin. Use the following equation to calculate the capacitance for the desired delay. C_{PDT} is the PDT external capacitor (μF):

$$C_{PDT} = 1.56 \times 10^{-4} [\mu F/ms] \cdot (t_{PDT} - 1ms)$$

Simplified Power On/Off Sequence

Figure 1 shows a simplified LTC2954-1 power on and power off sequence. A high to low transition on \overline{PB} (t_1) initiates the power on sequence. In order to assert the enable output, the \overline{PB} pin must stay low continuously (\overline{PB} high resets timers) for a time controlled by the default 32ms and the external ONT capacitor ($t_2 - t_1$). Once EN goes high (t_2), an internal 512ms blanking timer is started. This blanking timer is designed to give sufficient time for the DC/DC converter to reach its final voltage, and to allow the μP enough time to perform power on tasks.

The \overline{KILL} pin must be pulled high within 512ms of the EN pin going high. Failure to do so results in the EN pin going

APPLICATIONS INFORMATION

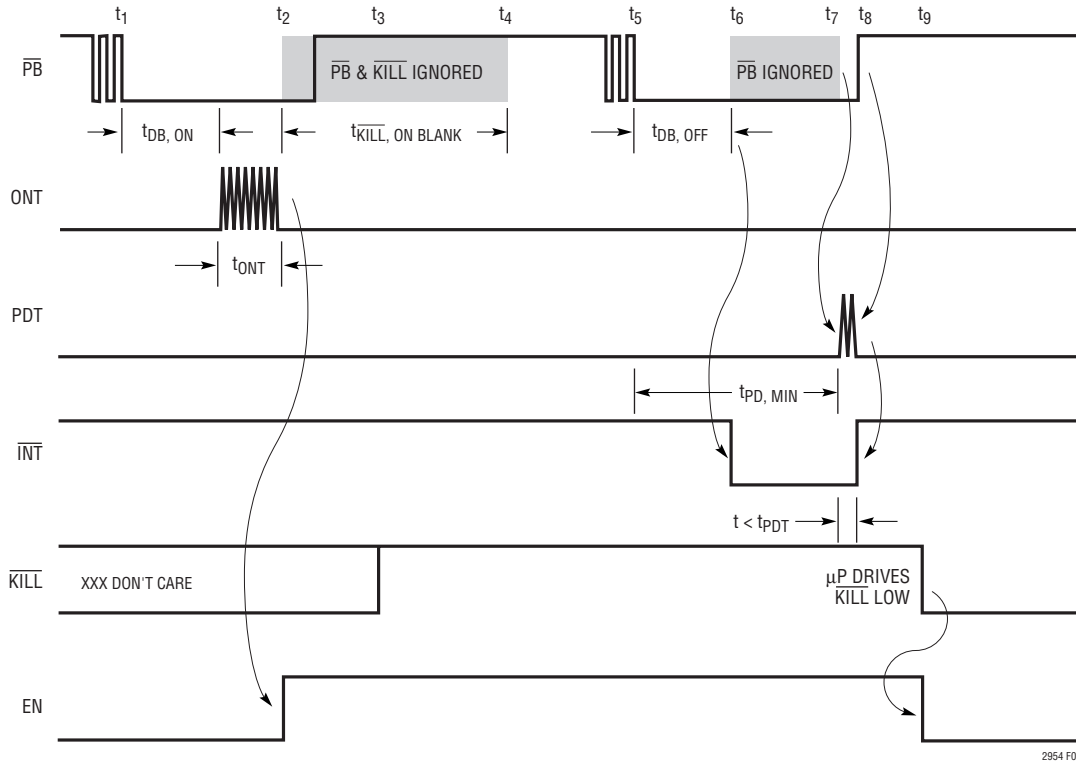

Figure 1. Simplified Power On/Off Sequence for LTC2954-1. μP Asserts \overline{KILL} after an Interrupt

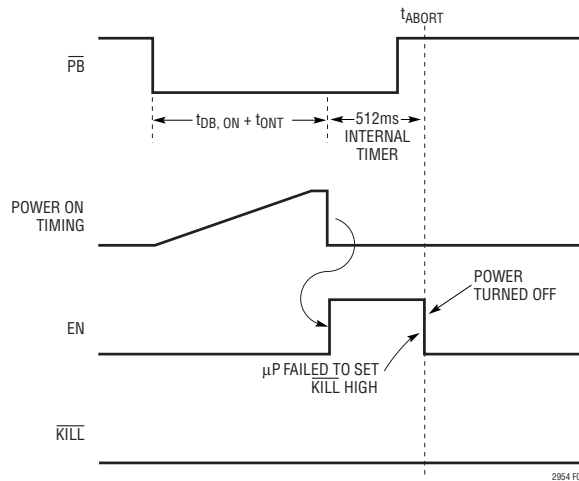

Figure 2. \overline{KILL} Remaining Low Aborts Power On Sequence for LTC2954-1

APPLICATIONS INFORMATION

low 512ms after it went high. Note that the LTC2954 does not sample $\overline{\text{KILL}}$ and $\overline{\text{PB}}$ until after the 512ms internal timer has expired. The reason $\overline{\text{PB}}$ is ignored is to ensure that the system is not forced off while powering on. Once the 512ms timer expires (t_4), the release of the $\overline{\text{PB}}$ pin is then debounced with an internal 32ms timer. The system has now properly powered on and the LTC2954 monitors $\overline{\text{PB}}$ and $\overline{\text{KILL}}$ for a turnoff command while consuming only 6 μA of supply current.

A high to low transition on $\overline{\text{PB}}$ (t_5) starts the power off sequence debounce timer. In order to assert the interrupt output ($\overline{\text{INT}}$), $\overline{\text{PB}}$ must stay low continuously ($\overline{\text{PB}}$ high resets debounce timer) for 32ms ($t_6 - t_5$). At the completion of the power down debounce timer (t_6), an internal interrupt timer keeps the interrupt output low for at least 32ms, even if $\overline{\text{PB}}$ is released between t_6 and t_7 . If $\overline{\text{PB}}$ is low at the end of this 32ms internal timer (t_7), the external adjustable power down timer is started. The capacitor placed at the PDT pin will determine the time period of this timer. If the push button is released prior to 16 cycles of the PDT pin, the interrupt output will go high (t_8). Note that the enable output is not directly changed by this interrupt pulse. The function of the interrupt signal is to initiate a software shutdown. At t_9 , the μP has performed its power down functions and asserted the $\overline{\text{KILL}}$ input low. This releases the enable output, which in turn shuts down system power. Note that if the push button is held long enough to count 16 cycles at the PDT pin, the enable pin would be released immediately after the 16th cycle. The

system is now in its reset state where the LTC2954 is in low power mode (6 μA) and $\overline{\text{PB}}$ is monitored for a high to low transition.

Aborted Power On Sequence

The power on sequence is aborted when the $\overline{\text{KILL}}$ remains low at the end of the 512ms blanking time. Figure 2 is a simplified version of an aborted power on sequence. At time t_{ABORT} , since $\overline{\text{KILL}}$ is still low, EN pulls low (thus turning off the DC/DC converter).

μP Turns Off Power During Normal Operation

Once the system has powered on and is operating normally, the μP can turn off power by setting $\overline{\text{KILL}}$ low, as shown in (Figure 3). At time $t_{\overline{\text{KILL}}}$, $\overline{\text{KILL}}$ is set low by the μP . This immediately pulls EN low, thus turning off the DC/DC converter.

DC/DC Turn Off Blanking

When the DC/DC converter is turned off, it can take a significant amount of time for its output to decay to ground. It is desirable to wait until the output of the DC/DC converter is near ground before allowing the user (via $\overline{\text{PB}}$) to restart the converter. This condition guarantees that the μP has always powered down completely before it is restarted.

Figure 4 shows the μP turning power off. After a low on $\overline{\text{KILL}}$ releases enable, the internal 256ms timer ignores the $\overline{\text{PB}}$ pin. This is shown as $t_{\text{EN}/\overline{\text{EN}}}$, LOCKOUT in (Figure 4).

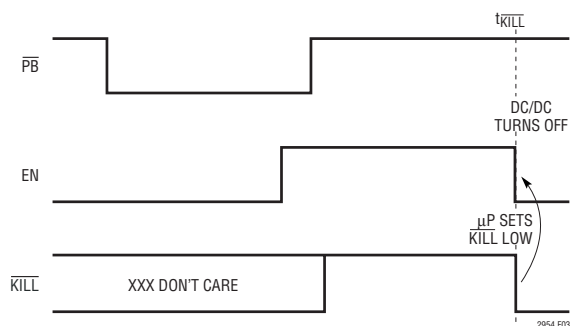

Figure 3. μP Turns Off Power (LTC2954-1)

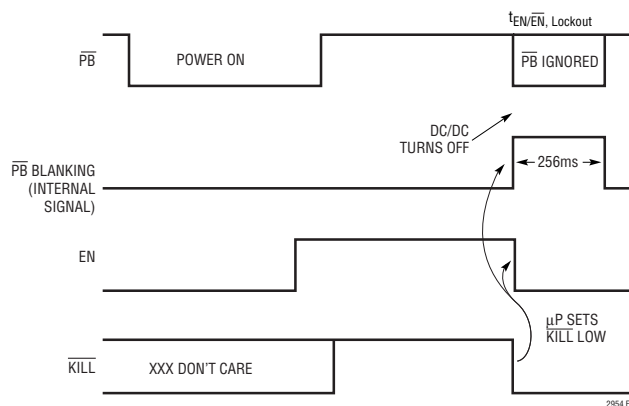

Figure 4. DC/DC Turn Off Blanking (LTC2954-1)

APPLICATIONS INFORMATION

LTC2954-1, LTC2954-2 Versions

The LTC2954-1 (high true EN) and LTC2954-2 (low true $\overline{\text{EN}}$) differ only by the polarity of the high voltage (33V ABS MAX), enable pin. The LTC2954-1 EN pin is a low leakage high true open drain output designed to drive the shutdown pin of DC/DC converters. The LTC2954-2 is a low leakage, low true open drain enable output designed to drive the gate of an external PFET. The LTC2954-2 provides a user manual power path control.

High Voltage Pins

The V_{IN} , $\overline{\text{PB}}$ and $\text{EN}/\overline{\text{EN}}$ pins can operate at voltages up to 26.4V. $\overline{\text{PB}}$ can, additionally, operate below ground (-6V)

without latching up the device. $\overline{\text{PB}}$ has an ESD HBM rating of $\pm 10\text{kV}$. If the push button switch connected to $\overline{\text{PB}}$ exhibits its high leakage current, then an external pull-up resistor to V_{IN} is recommended. Furthermore, if the push button switch is physically located far from the LTC2954 $\overline{\text{PB}}$ pin, parasitic capacitances may couple onto the high impedance $\overline{\text{PB}}$ input. Additionally, parasitic series inductance may cause unpredictable ringing at the $\overline{\text{PB}}$ pin. Placing a 5.1k resistor from the $\overline{\text{PB}}$ pin to the push button switch would mitigate parasitic inductance problems. Placing a $0.1\mu\text{F}$ capacitor on the $\overline{\text{PB}}$ pin would lessen the impact of parasitic capacitive coupling.

TYPICAL APPLICATIONS

Voltage Monitoring with $\overline{\text{KILL}}$ Input

The $\overline{\text{KILL}}$ pin can be used as a voltage monitor. Figure 5 shows an application where the $\overline{\text{KILL}}$ pin has a dual function. It is driven by a low leakage open drain output of the μP . It is also connected to a resistive divider that monitors battery voltage (V_{IN}). When the battery voltage falls below the set value, the voltage at the $\overline{\text{KILL}}$ pin falls below 0.6V and the EN pin is quickly pulled low. Note that the resistor values should be as large as possible, but small enough to keep leakage currents from tripping the 0.6V $\overline{\text{KILL}}$ comparator.

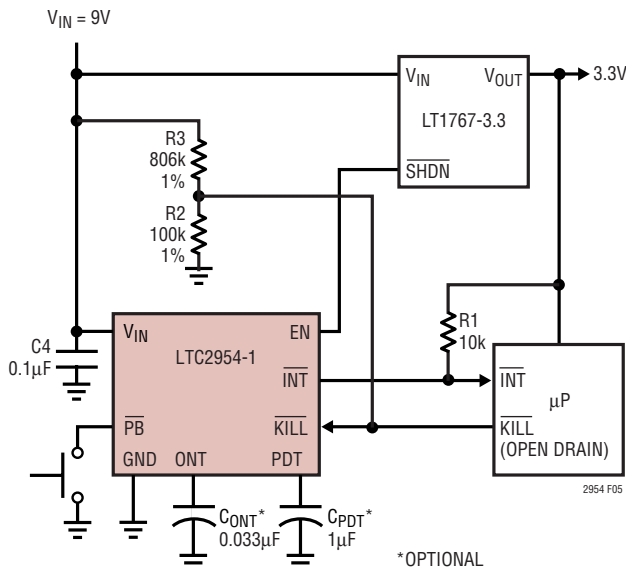

Figure 5. Input Voltage Monitoring with $\overline{\text{KILL}}$ Input

The DC/DC converter shown has an internal pull-up current on its $\overline{\text{SHDN}}$ pin. A pull-up resistor on EN is thus not needed.

Operation Without μP

Figure 6 shows how to connect the $\overline{\text{KILL}}$ pin when there is no circuitry available to drive it. The minimum pulse width detected is $30\mu\text{s}$. If there are glitches on the resistor pull-up voltage that are wider than $30\mu\text{s}$ and transition below 0.6V , then an appropriate bypass capacitor should be connected to the $\overline{\text{KILL}}$ pin. The optional C_{PDT} external

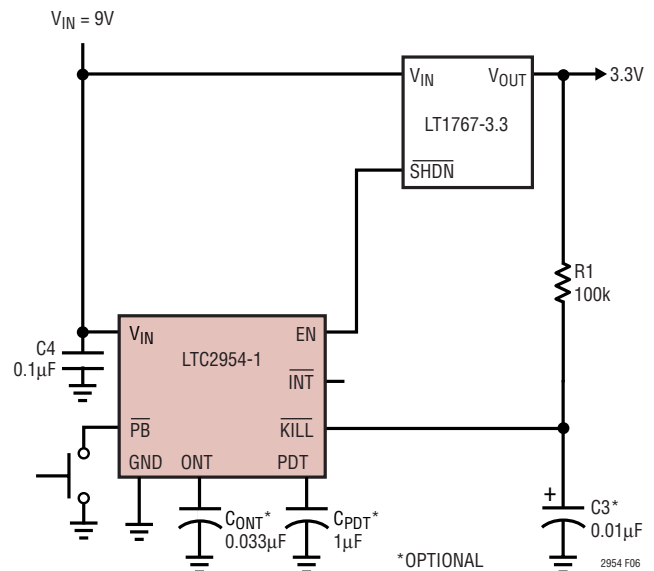

Figure 6. No μP Application

TYPICAL APPLICATIONS

capacitor extends the length of time (beyond 64ms) that the $\overline{\text{PB}}$ input must be held low before releasing the enable output.

High Voltage Power Path Switching

The high voltage $\overline{\text{EN}}$ open drain output of the LTC2954-2 is designed to switch on/off an external power PFET. This allows a user to connect/disconnect a power supply (or battery) to its load by toggling the $\overline{\text{PB}}$ pin. Figure 7 shows the LTC2954-2 controlling a two cell Li-Ion battery application. The $\overline{\text{KILL}}$ pin is connected to the output of the PFET through a resistive divider. The $\overline{\text{KILL}}$ pin serves as a voltage monitor. When V_{OUT} drops below 6V, causing a

$\overline{\text{KILL}}$ voltage below $V_{\overline{\text{KILL}}}(\text{TH})$, the $\overline{\text{EN}}$ pin becomes an open circuit 30 μs later. Since the PDT pin is open circuited, the power down debounce time defaults to 64ms.

$\overline{\text{PB}}$ Pin in a Noisy Environment

The rugged $\overline{\text{PB}}$ pin is designed to operate in noisy environments. Transients below ground ($> -6\text{V}$) and above V_{IN} ($< 33\text{V}$) will not damage the rugged $\overline{\text{PB}}$ pin. Additionally, the $\overline{\text{PB}}$ pin can withstand ESD HBM strikes up to $\pm 10\text{kV}$.

In order to keep external noise from coupling inside the LTC2954, place an R-C network close to the $\overline{\text{PB}}$ pin. A 5.1k resistor and a 0.1 μF capacitor should suffice for most noisy applications (see Figure 8).

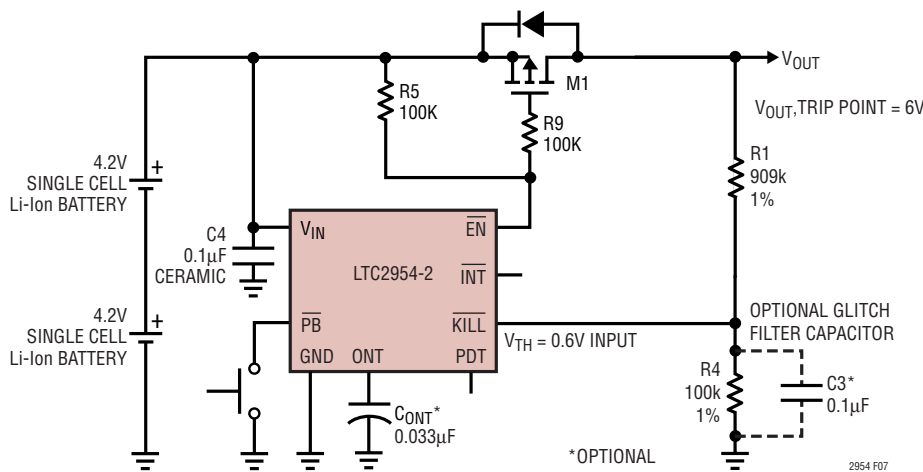

Figure 7. Power Path Control with 6V Under Voltage Detect

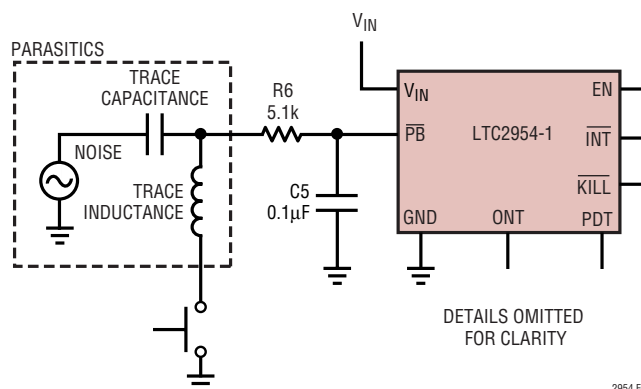

Figure 8. Noisy $\overline{\text{PB}}$ Trace

TYPICAL APPLICATIONS

External Pull-Up Resistor on \overline{PB}

An internal pull-up resistor on the \overline{PB} pin makes an external pull-up resistor unnecessary. Leakage current on the \overline{PB} board trace, however, will affect the open circuit voltage on the \overline{PB} pin. If the leakage is too large ($>2\mu\text{A}$), the \overline{PB} voltage may fall close to the threshold window. To mitigate the effect of the board leakage, a 10k resistor to V_{IN} is recommended (see Figure 9).

Reverse Battery Protection

To protect the LTC2954 from a reverse battery connection, place a 1k resistor in series with the V_{IN} pin (see Figure 10).

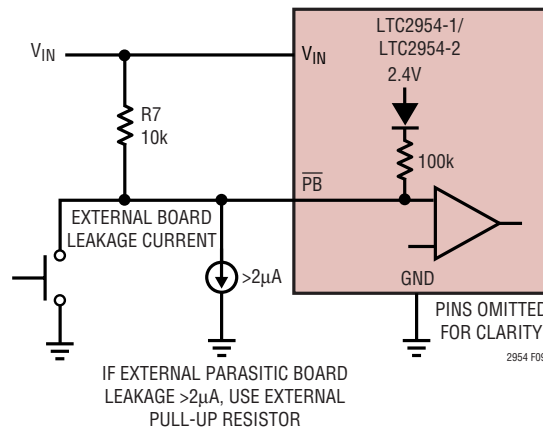
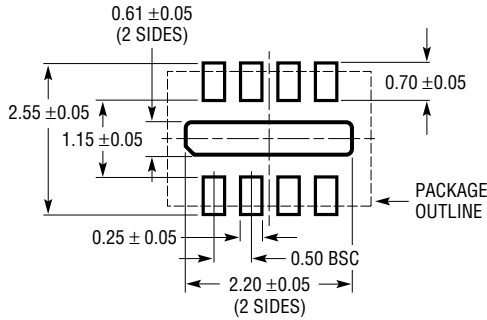

Figure 9. External Pull-Up Resistor on \overline{PB} Pin

PACKAGE DESCRIPTION

DDB Package 8-Lead Plastic DFN (3mm × 2mm) (Reference LTC DWG # 05-08-1702 Rev B)



RECOMMENDED SOLDER PAD PITCH AND DIMENSIONS

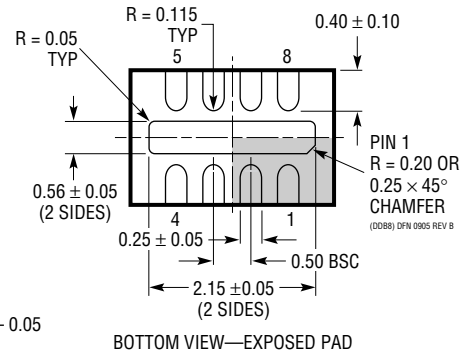
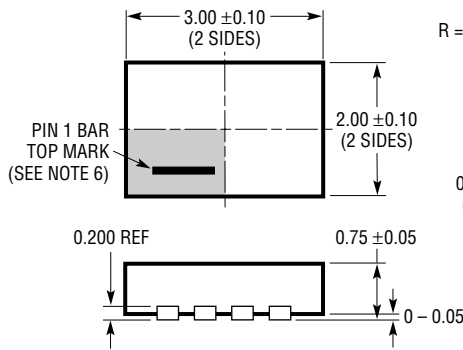

BOTTOM VIEW—EXPOSED PAD

NOTE:

1. DRAWING CONFORMS TO VERSION (WECD-1) IN JEDEC PACKAGE OUTLINE M0-229
2. DRAWING NOT TO SCALE
3. ALL DIMENSIONS ARE IN MILLIMETERS
4. DIMENSIONS OF EXPOSED PAD ON BOTTOM OF PACKAGE DO NOT INCLUDE MOLD FLASH. MOLD FLASH, IF PRESENT, SHALL NOT EXCEED 0.15mm ON ANY SIDE
5. EXPOSED PAD SHALL BE SOLDER PLATED
6. SHADED AREA IS ONLY A REFERENCE FOR PIN 1 LOCATION ON THE TOP AND BOTTOM OF PACKAGE

TS8 Package 8-Lead Plastic TSOT-23 (Reference LTC DWG # 05-08-1637)

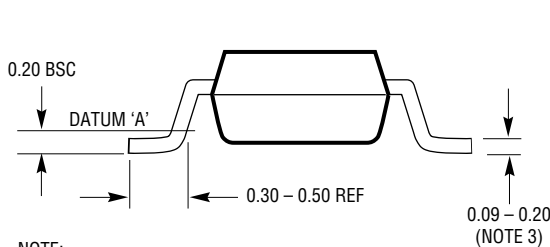
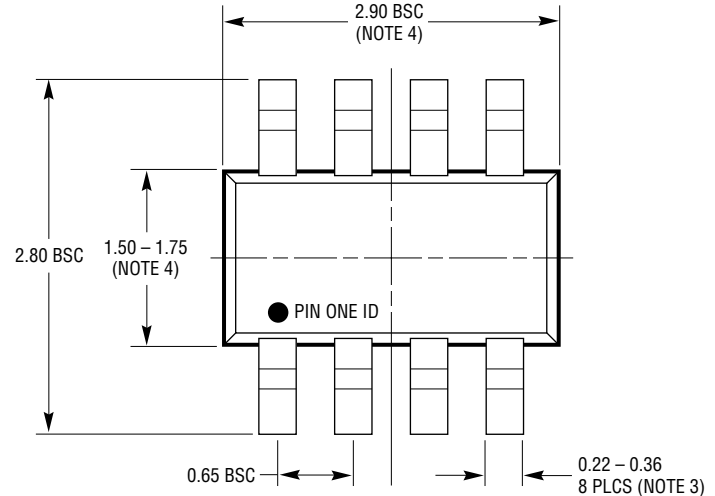
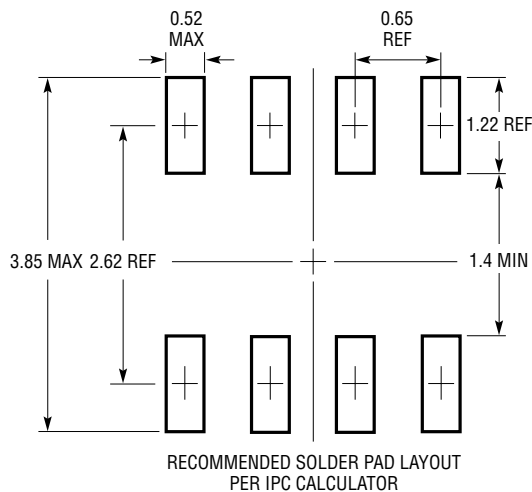

NOTE:

1. DIMENSIONS ARE IN MILLIMETERS
2. DRAWING NOT TO SCALE
3. DIMENSIONS ARE INCLUSIVE OF PLATING
4. DIMENSIONS ARE EXCLUSIVE OF MOLD FLASH AND METAL BURR
5. MOLD FLASH SHALL NOT EXCEED 0.254mm
6. JEDEC PACKAGE REFERENCE IS M0-193

TS8 TSOT-23 0802

TYPICAL APPLICATION

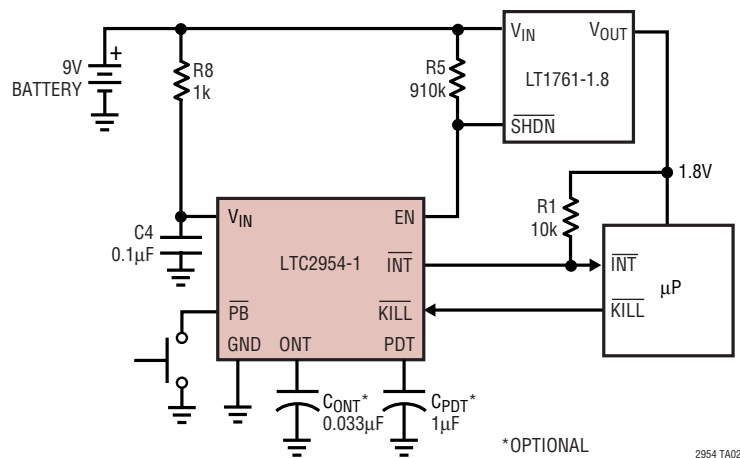

Figure 10. Reverse Battery Protection

RELATED PARTS

PART NUMBER	DESCRIPTION	COMMENTS
LTC2900	Programmable Quad Supply Monitor	Adjustable $\overline{\text{RESET}}$, 10-Lead MSOP and 3mm x 3mm DFN Packages
LLTC2904/LTC2905	Pin-Programmable Dual Supply Monitors	Adjustable $\overline{\text{RESET}}$ and Tolerance, 8-Lead SOT-23 and 3mm x 2mm DFN Packages
TC2909	Precision Triple/Dual Input UV, OV and Negative Voltage Monitor	6.5V Shunt Regulator for High Voltage Operation
LTC2910	Octal Positive/Negative Voltage Monitor	Eight Adjustable Inputs (0.5V)
LTC2914	Quad UV/OV Positive/Negative Voltage Monitor	Adjustable UV and OV Trip Values
LTC2950/LTC2951	Push Button On/Off Controllers	High Voltage, Low Power Push Button Controller with Power Down Fault Detect KILL Timer
LTC4411	2.6A Low Loss Ideal Diode in ThinSOT	No External MOSFET, Automatic Switching Between DC Sources
LTC4412HV	Power Path Controller in ThinSOT	Efficient Diode-ORing, Automatic Switching Between DC Sources, 3V to 36V
LTC4055	USB Power Controller and Li-Ion Charger	Automatic Switchover, Charges 1-Cell Li-Ion Batteries
LT4351	MOSFET Diode-OR Controller	Wide Input Range: 1.2V to 18V