

## FEATURES

- Dual Band RF Power Amplifier Control (LTC1957-2)
- Internal Schottky Diode Detector with Improved Dynamic Range vs the LTC1757A
- Wide Input Frequency Range: 850MHz to 2GHz
- Autozero Loop Cancels Offset Errors and Temperature Dependent Offsets
- Wide  $V_{IN}$  Range: 2.7V to 6V
- Allows Direct Connection to Battery
- RF Output Power Set by External DAC
- Fast Acquire After Transmit Enable
- Internal Frequency Compensation
- Rail-to-Rail Power Control Outputs
- Power Control Signal Overvoltage Protection
- Low Operating Current: 1mA
- Very Low Shutdown Current:  $< 1\mu A$
- Available in a 8-Pin MSOP Package (LTC1957-1) and 10-Pin MSOP (LTC1957-2)
- Pin Compatible with the LTC1757A-X
- Improved Start Voltage Accuracy and Range
- Improved PCTL Input Filtering

## APPLICATIONS

- Single and Dual Band GSM/GPRS Cellular Telephones
- PCS Devices
- Wireless Data Modems
- U.S. TDMA Cellular Phones

## DESCRIPTION

The LTC<sup>®</sup>1957-2 is a dual band RF power controller for power amplifiers operating in the 850MHz to 2GHz range. The input voltage range is optimized for operation from a single lithium-ion cell or  $3\times$  NiMH. Several functions required for RF power control and protection are integrated in one small 10-pin MSOP package, thereby minimizing PCB area.

The LTC1957-1 is a single output RF power controller that is identical in performance to the LTC1957-2 except that one output ( $V_{PCA}$ ) is provided. The LTC1957-1 can be used to drive a single RF or dual channel module with integral multiplexer. This part is available in an 8-pin MSOP package.

RF power is controlled by driving the RF amplifier power control pins and sensing the resultant RF output power via a directional coupler. The RF sense voltage is peak detected using an on-chip Schottky diode. This detected voltage is compared to the DAC voltage at the PCTL pin to control the output power. The RF power amplifier is protected against high supply current and high power control pin voltages.

Internal and external offsets are cancelled over temperature by an autozero control loop, allowing accurate low power programming. The shutdown feature disables the part and reduces the supply current to  $< 1\mu A$ .

 LTC and LT are registered trademarks of Linear Technology Corporation.

## TYPICAL APPLICATION

LTC1957-2 Dual Band Cellular Telephone Transmitter

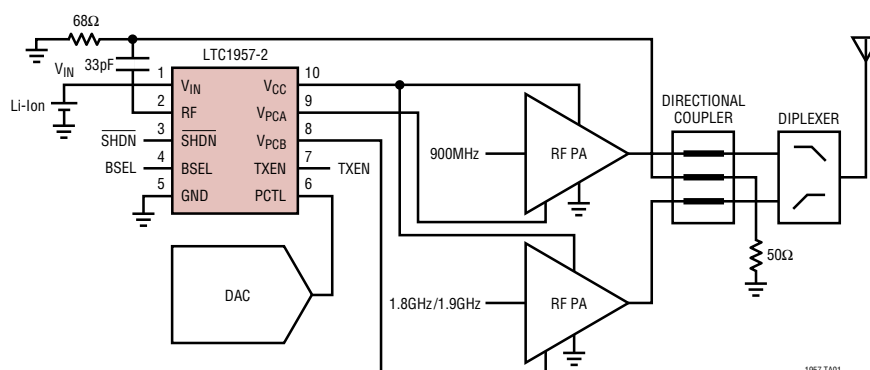

# LTC1957-1/LTC1957-2

## ABSOLUTE MAXIMUM RATINGS (Note 1)

$V_{IN}$ to GND .....	-0.3V to 6.5V	$I_{V_{PCA/B}}$ , 25% Duty Cycle .....	20mA
$V_{PCA}$ , $V_{PCB}$ Voltage .....	-0.3V to 3V	Operating Temperature Range (Note 2) .	-30°C to 85°C
PCTL Voltage .....	-0.3V to ( $V_{IN} + 0.3V$ )	Storage Temperature Range .....	-65°C to 150°C
RF Voltage .....	( $V_{IN} - 2.2V$ ) to 7V	Maximum Junction Temperature .....	125°C
$I_{V_{CC}}$ , Continuous .....	1A	Lead Temperature (Soldering, 10 sec).....	300°C
$I_{V_{CC}}$ , 12.5% Duty Cycle .....	2.5A		
SHDN, TXEN, BSEL			
Voltage to GND .....	-0.3V to ( $V_{IN} + 0.3V$ )		

## PACKAGE/ORDER INFORMATION

<p>MS8 PACKAGE 8-LEAD PLASTIC MSOP <math>T_{JMAX} = 125^{\circ}C</math>, <math>\theta_{JA} = 160^{\circ}C/W</math></p>	ORDER PART NUMBER	<p>MS10 PACKAGE 10-LEAD PLASTIC MSOP <math>T_{JMAX} = 125^{\circ}C</math>, <math>\theta_{JA} = 160^{\circ}C/W</math></p>	ORDER PART NUMBER
	LTC1957-1EMS8		LTC1957-2EMS
	MS8 PART MARKING		MS10 PART MARKING
	LTRH		LTRJ

Consult LTC Marketing for parts specified with wider operating temperature ranges.

## ELECTRICAL CHARACTERISTICS

The ● denotes specifications which apply over the full operating temperature range, otherwise specifications are at  $T_A = 25^{\circ}C$ .  $V_{IN} = 3.6V$ , SHDN = TXEN = HI, unless otherwise noted.

PARAMETER	CONDITIONS	MIN	TYP	MAX	UNITS	
$V_{IN}$ Operating Voltage		● 2.7		6	V	
$I_{VIN}$ Shutdown Current	SHDN = LO, TXEN = LO, BSEL = LO	●		1	$\mu A$	
$I_{VIN}$ Autozero Current	SHDN = HI, TXEN = LO	●	1	1.6	mA	
$I_{VIN}$ Operating Current	SHDN = HI, TXEN = HI, $I_{V_{PCA}} = I_{V_{PCB}} = 0mA$ , $V_{PCA/B} = HI$		1.1	1.7	mA	
$I_{V_{CC}}$ Current Limit			2.2		A	
$V_{IN}$ to $V_{CC}$ Resistance	SHDN = LO, TXEN = LO		90	150	$m\Omega$	
$V_{PCA/B} V_{OL}$	TXEN = HI, Open Loop, PCTL = -100mV	●	0	0.1	V	
$V_{PCA/B}$ Dropout Voltage	$I_{LOAD} = 5.5mA$ , $V_{IN} = 2.7V$	●		$V_{IN} - 0.28$	V	
$V_{PCA/B}$ Voltage Clamp	$R_{LOAD} = 400\Omega$ , PCTL = 2V, External Gain = 0.417	●	2.7	2.85	3.0	V
$V_{PCA/B}$ Output Current	$V_{PCA/B} = 2.4V$ , $V_{IN} = 2.7V$	●	5.5	9	mA	
	$V_{PCA/B} = 2.6V$ , $V_{IN} = 3V$	●	6.0	10	mA	
$V_{PCA/B}$ Enable Time	$V_{PCTL} = 2V$ Step, $C_{LOAD} = 100pF$ (Note 5)	●		440	650	ns
$V_{PCA/B}$ Bandwidth	$C_{LOAD} = 100pF$ , $R_{LOAD} = 400\Omega$ (Note 8)	●	280	370	500	kHz
$V_{PCA/B}$ Load Capacitance	(Note 6)			100	pF	
$V_{PCA/B}$ Slew Rate	$V_{PCTL} = 2V$ Step, $C_{LOAD} = 100pF$ (Note 3)	●	1.2	2.2	V/ $\mu s$	
$V_{PCA/B}$ Droop	$V_{IN} = 2.7V$ , $V_{PCTL} = 2V$ Step		$\pm 1$		$\mu V/ms$	
$V_{PCA/B}$ TXEN Start Voltage	Open Loop, TXEN Low to High, $C_{LOAD} = 100pF$ (Note 9)		500	600	700	mV

## ELECTRICAL CHARACTERISTICS

The ● denotes specifications which apply over the full operating temperature range, otherwise specifications are at  $T_A = 25^\circ\text{C}$ .  $V_{IN} = 3.6\text{V}$ ,  $\overline{\text{SHDN}} = \text{TXEN} = V_{IN}$ , unless otherwise noted.

PARAMETER	CONDITIONS		MIN	TYP	MAX	UNITS
SHDN Input Threshold	$V_{IN} = 2.7\text{V}$ to $6\text{V}$ , $\text{TXEN} = \text{LO}$	●	0.35		1.4	V
TXEN, BSEL Input Threshold	$V_{IN} = 2.7\text{V}$ to $6\text{V}$	●	0.35		1.4	V
$\overline{\text{SHDN}}$ , TXEN, BSEL Input Current	$\overline{\text{SHDN}}$ , TXEN or BSEL = $3.6\text{V}$	●	10	25	50	$\mu\text{A}$
PCTL Input Voltage Control Range	$V_{IN} = 3\text{V}$ to $6\text{V}$ , $R_{\text{LOAD}} = 400\Omega$	●	0		2	V
PCTL Input Voltage Range	$V_{IN} = 3\text{V}$ , $R_{\text{LOAD}} = 400\Omega$ (Note 7)	●			2.4	V
PCTL Input Resistance	$\overline{\text{SHDN}} = \text{LO}$ , $\text{TXEN} = \text{LO}$	●	50	90	140	$\text{k}\Omega$
PCTL Input Filter				350		$\text{kHz}$
Autozero Range	$V_{IN} = 2.7\text{V}$ , $R_{\text{LOAD}} = 400\Omega$ (Note 4)	●			400	mV
Autozero Settling Time ( $t_S$ )	$t_S$ , Shutdown to Enable (Autozero), $V_{IN} = 2.7\text{V}$ (Note 10)	●			50	$\mu\text{s}$
RF Input Frequency Range	(Note 6)	●	850		2000	MHz
RF Input Power Range	900MHz (Note 6) 1800MHz (Note 6)		-26 -24		16 16	$\text{dBm}$ $\text{dBm}$
RF Input Impedance	Referenced to $V_{IN}$ , $\overline{\text{SHDN}} = \text{LO}$ , $\text{TXEN} = \text{LO}$	●	100	200	350	$\Omega$
BSEL Timing	$t_1$ , Setup Time Prior to TXEN Asserted High $t_2$ , Hold Time After TXEN is Asserted Low			200 200		ns ns

**Note 1:** Absolute Maximum Ratings are those values beyond which the life of a device may be impaired.

**Note 2:** The LTC1957-1 and LTC1957-2 are guaranteed to meet performance specifications from  $0^\circ\text{C}$  to  $70^\circ\text{C}$ . Specifications over the  $-30^\circ\text{C}$  to  $85^\circ\text{C}$  operating temperature range are assured by design, characterization and correlation with statistical process controls.

**Note 3:** Slew rate is measured open loop. The slew time at  $V_{\text{PCA}}$  or  $V_{\text{PCB}}$  is measured between 1V and 2V.

**Note 4:** Maximum DAC zero-scale offset voltage that can be applied to PCTL.

**Note 5:** This is the time from TXEN rising edge 50% switch point to  $V_{\text{PCA/B}} = 1\text{V}$ .

**Note 6:** Guaranteed by design. This parameter is not production tested.

**Note 7:** Includes maximum DAC offset voltage and maximum control voltage.

**Note 8:** Bandwidth is calculated using the 10% to 90% rise time:

$$\text{BW} = 0.35/\text{rise time}$$

**Note 9:** Measured  $1\mu\text{s}$  after  $\text{TXEN} = \text{HI}$ .

**Note 10:** 50% switch point,  $\overline{\text{SHDN}} \text{ HI} = V_{IN}$ ,  $\text{TXEN HI} = V_{IN}$ .

## TYPICAL PERFORMANCE CHARACTERISTICS

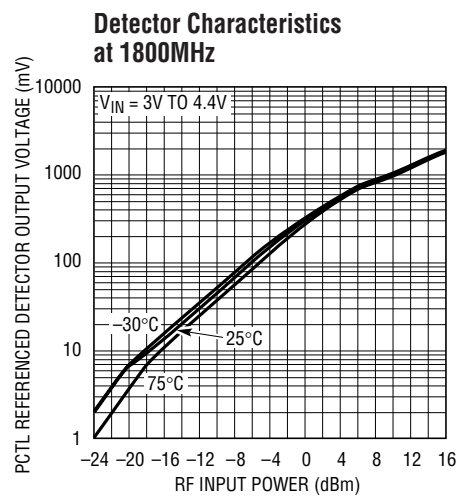
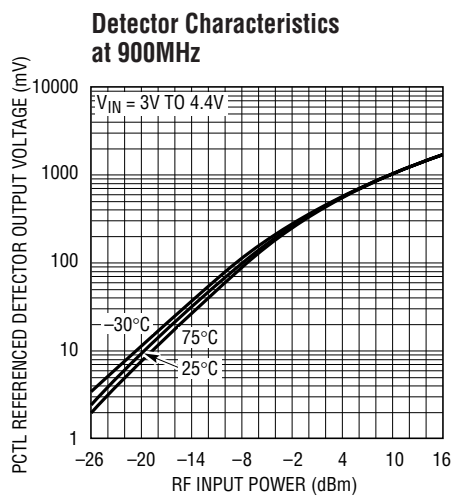

## PIN FUNCTIONS (LTC1957-2/LTC1957-1)

**$V_{IN}$  (Pin 1):** Input Supply Voltage, 2.7V to 6V.  $V_{IN}$  should be bypassed with 0.1 $\mu$ F and 100pF ceramic capacitors. Used as return for RF 200 $\Omega$  termination.

**RF (Pin 2):** RF Feedback Voltage from the Directional Coupler. Referenced to  $V_{IN}$ . A coupling capacitor of 33pF must be used to connect to the ground referenced directional coupler. The frequency range is 850MHz to 2000MHz. This pin has an internal 200 $\Omega$  termination, an internal Schottky diode detector and peak detector capacitor.

**SHDN (Pin 3):** Shutdown Input. A logic low on the SHDN pin places the part in shutdown mode. A logic high places the part in autozero when TXEN is low. SHDN has an internal 150k pull-down resistor to ensure that the part is in shutdown when the drivers are in a three-state condition.

**BSEL (Pin 4): (LTC1957-2 Only)** Selects  $V_{PCA}$  when low and  $V_{PCB}$  when high. This input has an internal 150k resistor to ground.

**GND (Pin 5/Pin 4):** System Ground.

**PCTL (Pin 6/Pin 5):** Analog Input. The external power control DAC drives this input. The amplifier serves the RF

power until the RF detected signal equals the DAC signal. The input impedance is typically 90k $\Omega$ .

**TXEN (Pin 7/Pin 6):** Transmit Enable Input. A logic high enables the control amplifier. When TXEN is low and SHDN is high the part is in the autozero mode. This input has an internal 150k resistor to ground.

**$V_{PCB}$  (Pin 8): (LTC1957-2 Only)** Power Control Voltage Output. This pin drives an external RF power amplifier power control pin. The maximum load capacitance is 100pF. The output is capable of rail-to-rail swings at low load currents. Selected when BSEL is high.

**$V_{PCA}$  (Pin 9/Pin 7):** Power Control Voltage Output. This pin drives an external RF power amplifier power control pin. The maximum load capacitance is 100pF. The output is capable of rail-to-rail swings at low load currents. Selected when BSEL is low (LTC1957-2 only).

**$V_{CC}$  (Pin 10/Pin 8):** RF Power Amplifier Supply. This pin has an internal 0.050 $\Omega$  sense resistor between  $V_{IN}$  and  $V_{CC}$  that senses the RF power amplifier supply current to detect overcurrent conditions.

**BLOCK DIAGRAM** (LTC1957-2)

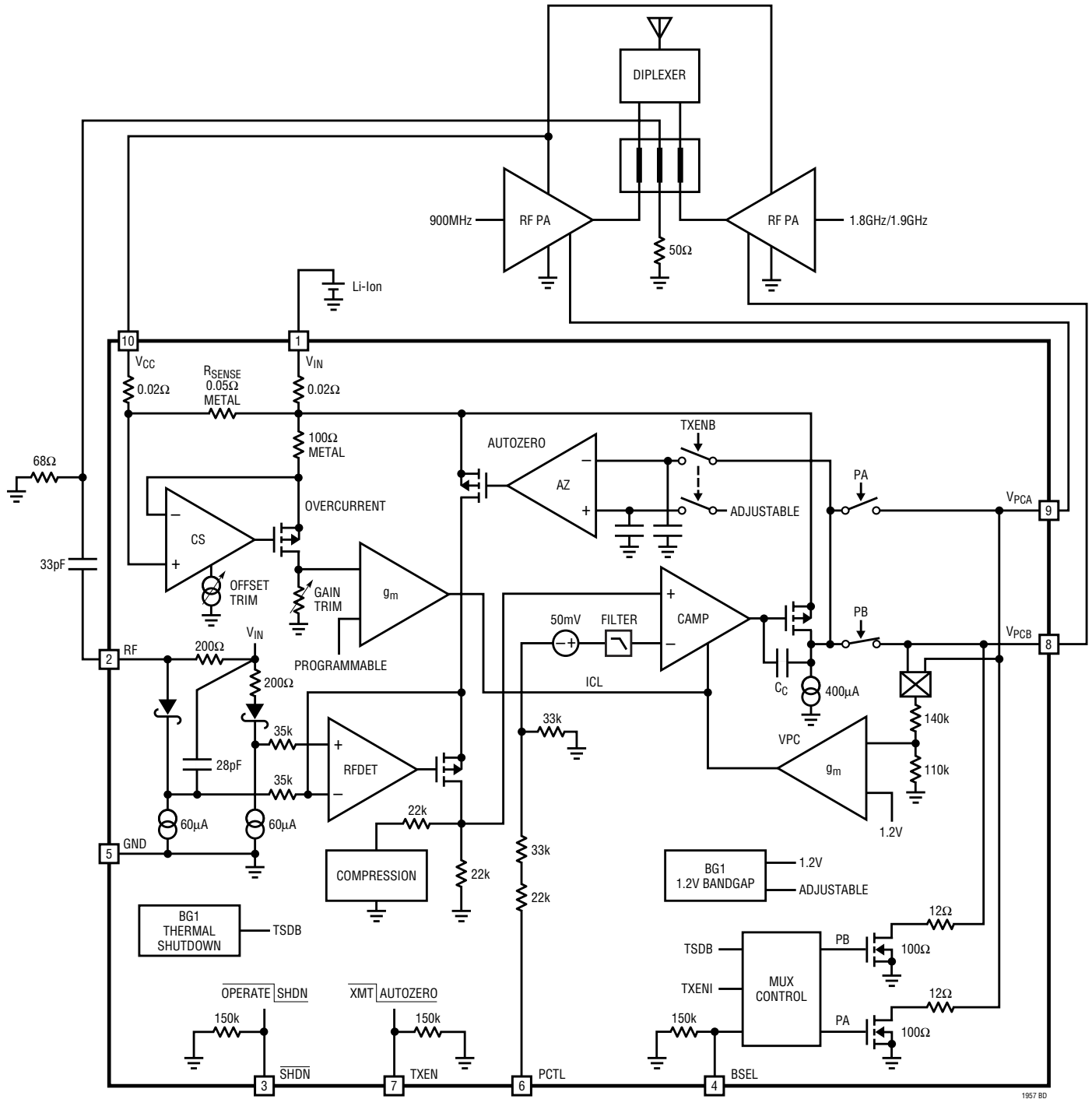

## APPLICATIONS INFORMATION

### Forward

The LTC1957 is an improved version of the LTC1757A. The Schottky diode detector dynamic range has been extended to over 40dB. The start voltage accuracy has been improved to  $\pm 17\%$ . The autozero hold time has been increased for applications requiring transmit times of several hundred milliseconds. The PCTL input filter bandwidth has been reduced to 350kHz for improved rejection of DAC noise as well as smoother ramp shaping.

### Operation

The LTC1957-2 dual band RF power control amplifier integrates several functions to provide RF power control over frequencies ranging from 850MHz to 2GHz. The device also prevents damage to the RF power amplifier due to overvoltage or overcurrent conditions. These functions include an internally compensated power control amplifier to control the RF output power, an autozero section to cancel internal and external voltage offsets, a sense amplifier with an internal sense resistor to limit the maximum RF power amplifier current, an RF Schottky diode peak detector and amplifier to convert the RF feedback signal to DC, a  $V_{PCA/B}$  overvoltage clamp, compression, a bandgap reference, a thermal shutdown circuit and a multiplexer to switch the control amplifier output to either  $V_{PCA}$  or  $V_{PCB}$ .

### Band Selection

The LTC1957-2 is designed for dual band operation. The BSEL pin will select output  $V_{PCA}$  when low and output  $V_{PCB}$  when high. For example,  $V_{PCA}$  could be used to drive a 900MHz channel and  $V_{PCB}$  a 1.8GHz/1.9GHz channel. BSEL must be established before the part is enabled. The LTC1957-1 can be used to drive a single RF channel or dual channel with integral multiplexer.

### Control Amplifier

The control amplifier supplies the power control voltage to the RF power amplifier. A portion (typically  $-19\text{dB}$  for low frequencies and  $-14\text{dB}$  for high frequencies) of the RF output voltage is sampled, via a directional coupler, to close the gain control loop. When a DAC voltage is applied to PCTL, the amplifier quickly servos  $V_{PCA}$  or  $V_{PCB}$  positive until the detected feedback voltage applied to the RF pin matches the voltage at PCTL. This feedback loop provides accurate RF power control.  $V_{PCA}$  or  $V_{PCB}$  are capable of driving a 5.5mA load current and 100pF load capacitor.

### RF Detector

The internal RF Schottky diode peak detector and amplifier converts the RF feedback voltage from the directional coupler to a low frequency voltage. This voltage is compared to the DAC voltage at the PCTL pin by the control amplifier to close the RF power control loop. The RF pin input resistance is typically  $200\Omega$  and the frequency range of this pin is 850MHz to 2000MHz. The detector demonstrates excellent efficiency and linearity over a wide range of input power. The Schottky detector is biased at about  $60\mu\text{A}$  and drives an on-chip peak detector capacitor of 28pF.

### Autozero

An autozero system is included to improve power programming accuracy over temperature. This section cancels internal offsets associated with the Schottky diode detector and control amplifier. External offsets associated with the DAC driving the PCTL pin are also cancelled. Offset drift due to temperature is cancelled between each burst. The maximum offset allowed at the DAC output is limited to 400mV. Autozeroing is performed when the part is in autozero mode ( $\overline{\text{SHDN}} = \text{high}$ ,  $\text{TXEN} = \text{low}$ ). When the part is enabled ( $\text{TXEN} = \text{high}$ ,  $\text{SHDN} = \text{high}$ ) the autozero capacitors are held and the  $V_{PCA}$  or  $V_{PCB}$  pin is connected to the control amplifier output. The hold droop voltage of typically  $< 1\mu\text{V}/\text{ms}$  provides for accurate offset

## APPLICATIONS INFORMATION

cancellation over the normal 1/8 duty cycle associated with the GSM protocol as well as multislot protocols. The part must be in the autozero mode for at least 50 $\mu$ s for autozero to settle to the correct value.

### Filter

There is a 350kHz filter included in the PCTL path.

### Protection Features

The RF power amplifier is overcurrent protected by an internal sense amplifier. The sense amplifier measures the voltage across an internal 0.050 $\Omega$  resistor to determine the RF power amplifier current.  $V_{PCA}$  or  $V_{PCB}$  is lowered as this supply current exceeds 2.2A, thereby regulating the current to about 2.25A. The regulated current limit is temperature compensated. The 0.050 $\Omega$  resistor and the current limit feature can be removed by connecting the PA directly to  $V_{IN}$ .

The RF power amplifier control voltage pins are overvoltage protected. The  $V_{PC}$  overvoltage clamp regulates  $V_{PCA}$  or  $V_{PCB}$  to 2.85V when the gain and PCTL input combination attempts to exceed this voltage.

The internal thermal shutdown circuit will disable the LTC1957-2 if the junction temperature exceeds approximately 150 $^{\circ}$ C. The part will be enabled when the temperature falls below 140 $^{\circ}$ C.

### Modes of Operation

The LTC1957-2 supports three operating modes: shutdown, autozero and enable.

In shutdown mode ( $\overline{\text{SHDN}}$  = Low) the part is disabled and supply currents will be reduced to <1 $\mu$ A.  $V_{PCA}$  and  $V_{PCB}$  will be connected to ground via 100 $\Omega$  switches.

In autozero mode ( $\overline{\text{SHDN}}$  = High, TXEN = Low)  $V_{PCA}$  and  $V_{PCB}$  will remain connected to ground and the part will be in the autozero mode. The part must remain in autozero for at least 50 $\mu$ s to allow for the autozero circuit to settle.

In enable mode ( $\overline{\text{SHDN}}$  = High, TXEN = High) the control loop and protection functions will be operational. When TXEN is switched high, acquisition will begin. The control amplifier will start to ramp the control voltage to the RF power amplifier. The RF amplifier will then start to turn on. The feedback signal from the directional coupler and the output power will be detected by the LTC1957-2 at the RF pin. The loop closes and the amplifier output tracks the DAC voltage ramping at PCTL. The RF power output will then follow the programmed power profile from the DAC.

MODE	SHDN	TXEN	OPERATION
Shutdown	Low	Low	Disabled
Autozero	High	Low	Autozero
Enable	High	High	Power Control

LTC1957-2 Timing Diagram

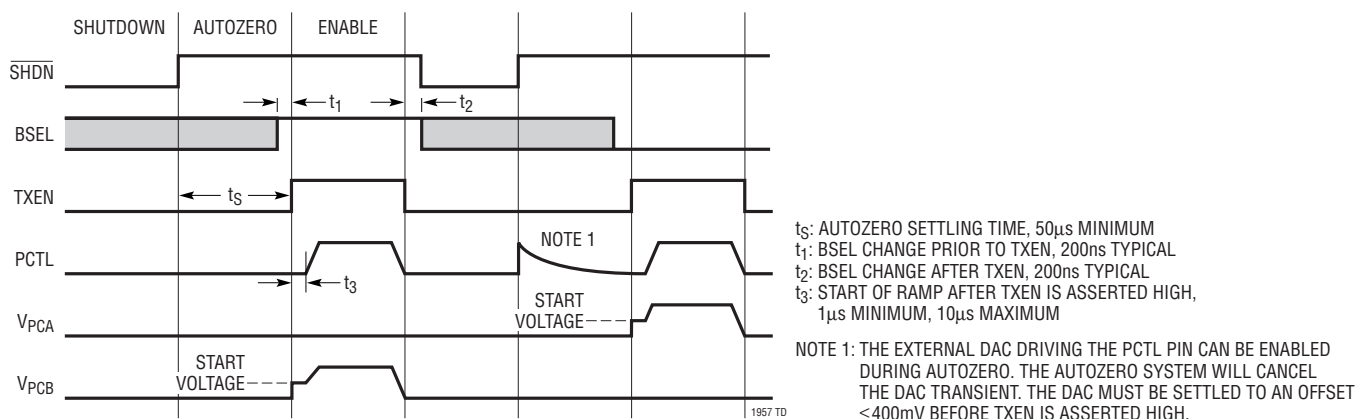

## APPLICATIONS INFORMATION

### LTC1957-1 Description

The LTC1957-1 is identical in performance to the LTC1957-2 except that only one control output ( $V_{PCA}$ ) is available. The LTC1957-1 can drive a single band (880MHz to 2000MHz) or a dual RF channel module with an internal multiplexer. Several manufacturers offer dual RF channel modules with an internal multiplexer.

### General Layout Considerations

The LTC1957-1/LTC1957-2 should be placed near the directional coupler. The feedback signal line to the RF pin should be a 50 $\Omega$  transmission line with optional termination or a short line. If short-circuit protection is used, bypass capacitors are required at  $V_{CC}$ .

### External Termination

The LTC1957 has an internal 200 $\Omega$  termination resistor at the RF pin. If a directional coupler is used, it is recommended that an external 68 $\Omega$  termination resistor be connected between the RF coupling capacitor (33pF), and ground at the side connected to the directional coupler. If the termination is placed at the LTC1957 RF pin, then the 68 $\Omega$  resistor must be connected to  $V_{IN}$  since the detector is referenced to  $V_{IN}$ . Termination components should be placed adjacent to the LTC1957.

### Power Ramp Profiles

The external voltage gain associated with the RF channel can vary significantly between RF power amplifier types. The LTC1957 frequency compensation has been optimized to be stable with several different power amplifiers and manufacturers. This frequency compensation generally defines the loop dynamics that impact the power/time response and possibly (slow loops) the power ramp sidebands. The LTC1957 operates open loop until an RF voltage appears at the RF pin, at which time the loop closes and the output power follows the DAC profile. The RF power amplifier will require a certain control voltage level (threshold) before an RF output signal is produced. The LTC1957  $V_{PCA/B}$  outputs must quickly rise to this threshold voltage in order to meet the power/time profile. To reduce this time, the LTC1957 starts at 600mV. However, at very low power levels the PCTL input signal is small, and

the  $V_{PCA/B}$  outputs may take several microseconds to reach the RF power amplifier threshold voltage. To reduce this time, it may be necessary to apply a positive pulse at the start of the ramp to quickly bring the  $V_{PCA/B}$  outputs to the threshold voltage. This can generally be achieved with DAC programming. The magnitude of the pulse is dependent on the RF amplifier characteristics.

Power ramp sidebands and power/time are also a factor when ramping to zero power. For RF amplifiers requiring high control voltages, it may be necessary to further adjust the DAC ramp profile. When the power is ramped down the loop will eventually open at power levels below the LTC1957 detector threshold. The LTC1957 will then go open loop and the output voltage at  $V_{PCA}$  or  $V_{PCB}$  will stop falling. If this voltage is high enough to produce RF output power, the power/time or power ramp sidebands may not meet specification. This problem can be avoided by starting the DAC ramp from 100mV (Figure 1). At the end of the cycle, the DAC can be ramped down to 0mV. This applies a negative signal to the LTC1957 thereby ensuring that the  $V_{PCA/B}$  outputs will ramp to 0V. The 100mV ramp step

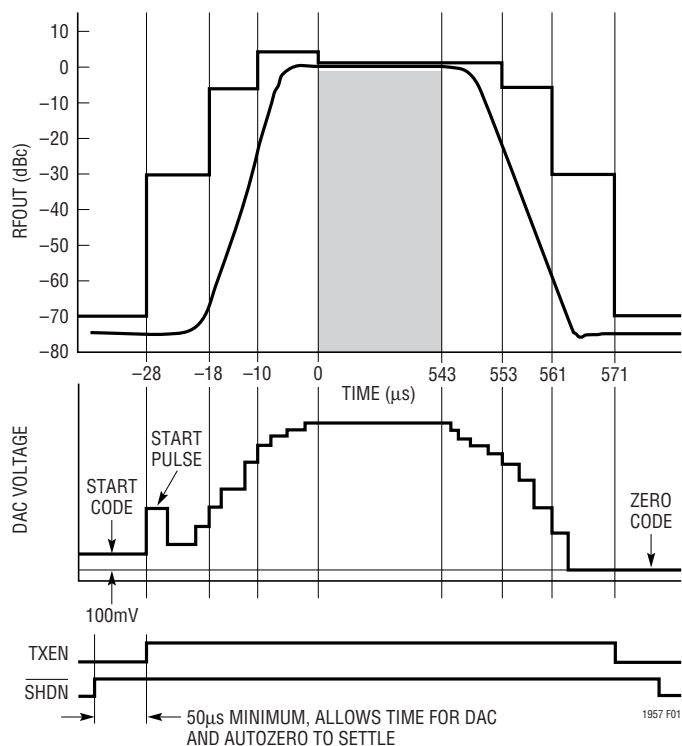

Figure 1. LTC1957 Ramp Timing



## APPLICATIONS INFORMATION

must be applied at least  $4\mu\text{s}$  before TXEN is asserted high to allow the autozero to cancel the step. Slow DAC rise times will extend this time by the additional RC time constants.

Another factor that affects power ramp sidebands is the DAC signal to PCTL. The bandwidth of the LTC1957 may not be low enough to adequately filter out steps associated with the DAC. If the baseband chip does not have an internal filter, it is recommended that a 1-stage external filter be placed between the DAC output and the PCTL pin. Resistor values should be kept below 2k since the PCTL input resistance is 90k. A typical filter scheme is shown in Figure 2.

The power control ramp should be started in the range of  $1\mu\text{s}$  to  $10\mu\text{s}$  after TXEN is asserted high.

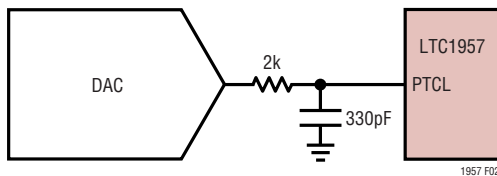

Figure 2

### Demo Board

The LTC1957 demo board is available upon request. The demo board has a 900MHz and an 1800MHz RF channel controlled by the LTC1957. Timing signals for TXEN are generated on the board using a 13MHz crystal reference. The PCTL power control pin is driven by a 10-bit DAC and the DAC profile can be loaded via a serial port. The serial port data is stored in a flash memory which is capable of storing eight ramp profiles. The board is supplied preloaded with four GSM power profiles and four DCS power profiles covering the entire power range. External timing signals can be used in place of the internal crystal controlled timing. A variety of RF power amplifiers are available.

### LTC1957 Control Loop Stability

The LTC1957 provides a stable control loop for several RF power amplifier models from different manufacturers over a wide range of frequencies, output power levels and  $V_{\text{SWR}}$  conditions. However, there are several factors that can improve or degrade loop frequency stability.

1) The additional voltage gain supplied by the RF power amplifier increases the loop gain raising poles normally below the 0dB axis. The extra voltage gain can vary significantly over input/output power ranges, frequency, power supply, temperature and manufacturer. RF power amplifier gain control transfer functions are often not available and must be generated by the user. Loop oscillations are most likely to occur in the midpower range where the external voltage gain associated with the RF power amplifier typically peaks. It is useful to measure the oscillation or ringing frequency to determine whether it corresponds to the expected loop bandwidth and thus is due to high gain bandwidth.

2) Loop voltage losses supplied by the directional coupler will improve phase margin. The larger the directional coupler loss the more stable the loop will become. However, larger losses reduce the RF signal to the LTC1957 and detector performance may be degraded at low power levels. (See RF Detector Characteristics.)

3) Additional poles within the loop due to filtering or the turn-on response of the RF power amplifier can degrade the phase margin if these pole frequencies are near the effective loop bandwidth frequency. Generally loops using RF power amplifiers with fast turn-on times have more phase margin. Extra filtering below 16MHz should never be placed within the control loop, as this will only degrade phase margin.

4) Control loop instability can also be due to open loop issues. RF power amplifiers should first be characterized in an open loop configuration to ensure self oscillation is not present. Self-oscillation is often related to poor power supply decoupling, ground loops, coupling due to poor layout and extreme  $V_{\text{SWR}}$  conditions. The oscillation frequency is generally in the 100kHz to 10MHz range. Power supply related oscillation suppression requires large value ceramic decoupling capacitors placed close to the RF power amp supply pins. The range of decoupling capacitor values is typically 1nF to  $3.3\mu\text{F}$ .

5) Poor layout techniques associated with the directional coupler area may result in high frequency signals bypassing the coupler. This could result in stability problems due to the reduction in the coupler loss.

## APPLICATIONS INFORMATION

### Determining External Loop Gain and Bandwidth

The external loop voltage gain contributed by the RF channel and directional coupler network should be measured in a closed loop configuration. A voltage step is applied to PCTL and the change in  $V_{PCA}$  (or  $V_{PCB}$ ) is measured. The detected voltage is  $0.6 \cdot PCTL$  and the external voltage gain contributed by the RF power amplifier and directional coupler network is  $0.6 \cdot \Delta V_{PCTL} / \Delta V_{PCA}$ . Measuring voltage gain in the closed loop configuration accounts for the nonlinear detector gain that is dependent on RF input voltage and frequency.

The LTC1957 unity gain bandwidth specified in the data sheet assumes that the net voltage gain contributed by the RF power amplifier and directional coupler is unity. The bandwidth is calculated by measuring the rise time between 10% and 90% of the voltage change at  $V_{PCA}$  or  $V_{PCB}$  for a small step in voltage applied to PCTL.

$$BW1 = 0.35 / \text{rise time}$$

The LTC1957 control amplifier unity gain bandwidth (BW1) is typically 370kHz. The phase margin of the control amplifier is typically 86°.

For PCTL voltages <650mV, the RF detected voltage is  $0.6PCTL$ . For PCTL voltages >650mV, RF detected voltage is  $1.18PCTL - 0.38$ . This change in gain is due to an internal compression circuit designed to extend the detector range.

For example, to determine the external RF channel loop voltage gain with the loop closed, apply a 100mV step to PCTL from 300mV to 400mV.  $V_{PCA}$  (or  $V_{PCB}$ ) will increase to supply enough feedback voltage to the RF pin to cancel this 100mV step which would be the required detected voltage of 60mV.  $V_{PCA}$  changed from 1.498V to 1.528V to create the RF output power change required. The net external voltage gain contributed by the RF power amplifier and directional coupler network can be calculated by dividing the 60mV change at the RF pin by the 30mV change at the  $V_{PCA}$  pin. The net external voltage gain would then be approximately 2. The loop bandwidth extends to  $2 \cdot BW1$ . If BW1 is 370kHz, the loop bandwidth increases to approximately 740kHz. The phase margin can be determined from Figures 3 and 4. Repeat the above voltage gain measurement over the full power and frequency range.

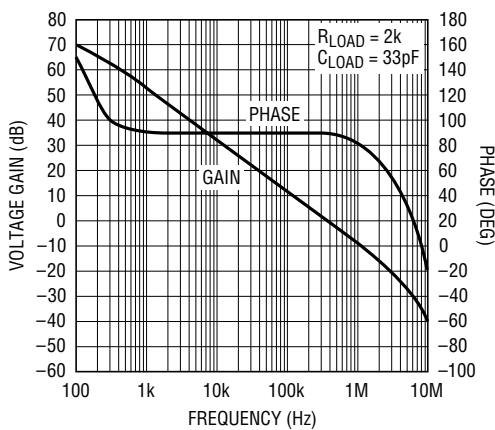

1957 F03

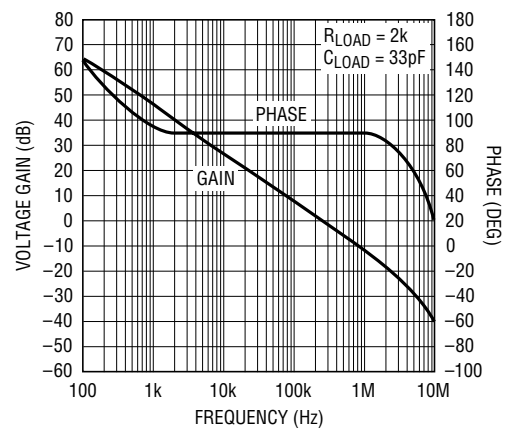

1957 F04

Figure 3. Measured Open Loop Gain and Phase, PCTL < 640mV

Figure 4. Measured Open Loop Gain and Phase, PCTL > 640mV

## APPLICATIONS INFORMATION



Figure 5. Closed Loop Block Diagram

External pole frequencies within the loop will further reduce phase margin. The phase margin degradation, due to external and internal pole combinations, is difficult to determine since complex poles are present. Gain peaking may occur, resulting in higher bandwidth and lower phase margin than predicted from the open loop Bode plot. A low frequency AC SPICE model of the LTC1957 power controller is included to better determine pole and zero interactions. The user can apply external gains and poles to determine bandwidth and phase margin. DC, transient and RF information cannot be extracted from the present model. The model is suitable for external gain evaluations up to  $6\times$ . The 350kHz PCTL input filter limits the bandwidth, therefore, use the RF input as demonstrated in the model.

This model (Figure 7) is being supplied to LTC users as an aid to circuit designs. While the model reflects reasonably close similarity to corresponding devices in low frequency AC performance terms, its use is not suggested as a replacement for breadboarding. Simulation should be used as a forerunner or a supplement to traditional lab testing.

Users should note very carefully the following factors regarding this model: Model performance in general will reflect typical baseline specs for a given device, and certain aspects of performance may not be modeled fully. While reasonable care has been taken in the preparation, we cannot be responsible for correct application on any and all computer systems. Model users are hereby notified that these models are supplied “as is”, with no direct or implied responsibility on the part of LTC for their operation

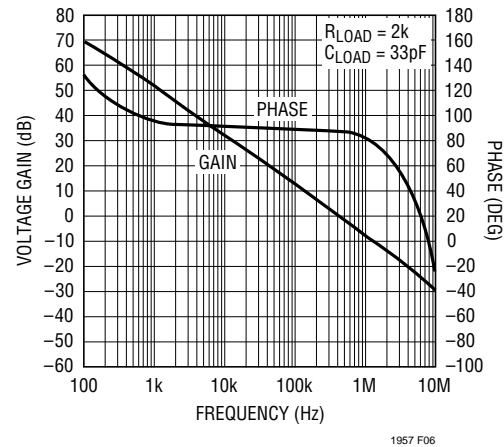

Figure 6. SPICE Model Open Loop Gain and Phase Characteristics from RF to  $V_{PCA}$ ,  $PCTL < 640mV$

within a customer circuit or system. Further, Linear Technology Corporation reserves the right to change these models without prior notice.

In all cases, the current data sheet information is your final design guideline, and is the only performance guarantee. For further technical information, refer to individual device data sheets. Your feedback and suggestions on this model is appreciated.

Linear Technology Corporation hereby grants the users of this model a nonexclusive, nontransferable license to use this model under the following conditions:

The user agrees that this model is licensed from Linear Technology and agrees that the model may be used, loaned, given away or included in other model libraries as long as this notice and the model in its entirety and unchanged is included. No right to make derivative works or modifications to the model is granted hereby. All such rights are reserved.

This model is provided as is. Linear Technology makes no warranty, either expressed or implied about the suitability or fitness of this model for any particular purpose. In no event will Linear Technology be liable for special, collateral, incidental or consequential damages in connection with or arising out of the use of this model. It should be remembered that models are a simplification of the actual circuit.

## APPLICATIONS INFORMATION

\*LTC1957 Low Frequency AC Spice Model\*

GIN1 ND2 0 ND1A IFB 100E-6

GX3 ND6 0 0 ND4 1E-6

GX4 ND7 0 0 ND6 1E-6

GX1 ND3 0 0 ND2 1E-6

GX2 ND4 0 0 ND3 1E-6

GX5 ND10 0 0 ND9 1E-6

GX8 ND14 0 0 ND12 1E-6

GX7 ND12 0 0 ND11 1E-6

GX6 ND11 0 0 ND10 1E-6

GXFB IFB 0 0 ND14 28.8E-6

EX1 ND8 0 0 ND7 1

RPCTL2 ND1 0 33E3

RFILT ND1 ND1A 50E3

RO1 ND2 0 70E6

RX3 ND6 0 1E6

RX4 ND7 0 1E6

RPCTL1 PCTL ND1 53E3

RX1 ND3 0 1E6

RX2 ND4 ND5 1E6

RSD RF ND9 500

RX5 ND10 0 1E6

RT RF 0 250

RX8 ND14 0 1E6

RX7 ND12 ND13 1E6

RX6 ND11 0 1E6

R9 ND8 ND8A 100

R9A ND8A VPCA 20

RLOAD VPCA 0 2E3

RFB1 IFB 0 22E3

CPCTL1 ND1A 0 7E-12

CX3 ND6 0 8E-15

CX4 ND7 0 12E-15

CC1 ND2 0 24E-12

CX1 ND3 0 2E-15

CX5 ND10 0 10E-15

CX6 ND11 0 1.2E-15

CLOAD VPCA 0 33E-12

CLINT ND8A 0 37E-12

CLINTA VPCA 0 18E-12

CFB1 IFB 0 300E-15

CP ND9 0 28E-12

LX2 ND5 0 34E-3

LX7 ND13 0 7E-3

\*\*Closed loop connections, comment-out VPCTLO, VRF, Adjust EFB gain to reflect external gain, currently set at 3X\*\*

\*EFB RF 0 VPCA VIN 3

VIN VIN 0 DC 0 AC 1

\*VPCTLO PCTL 0 DC 0

\*\*Open loop connections, comment-out EFB, VIN and VPCTLO\*\*

VPCTLO PCTL 0 DC 0

VRF RF 0 DC 0 AC 1

\*\*Add AC statement and print statement as required\*\*

.AC DEC 50 100 1E7

.END

Figure 7. LTC1957 Low Frequency AC SPICE Model

APPLICATIONS INFORMATION

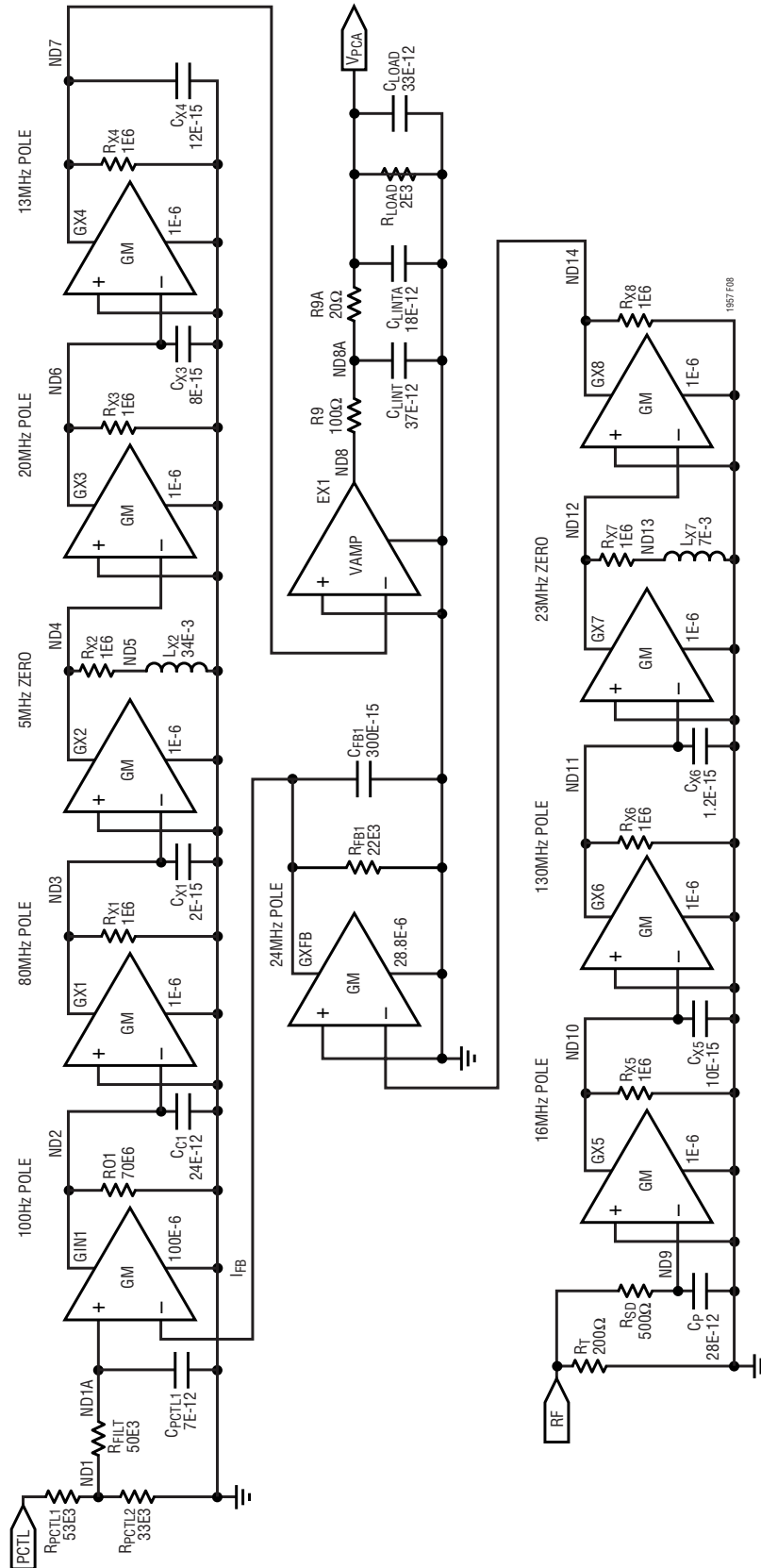
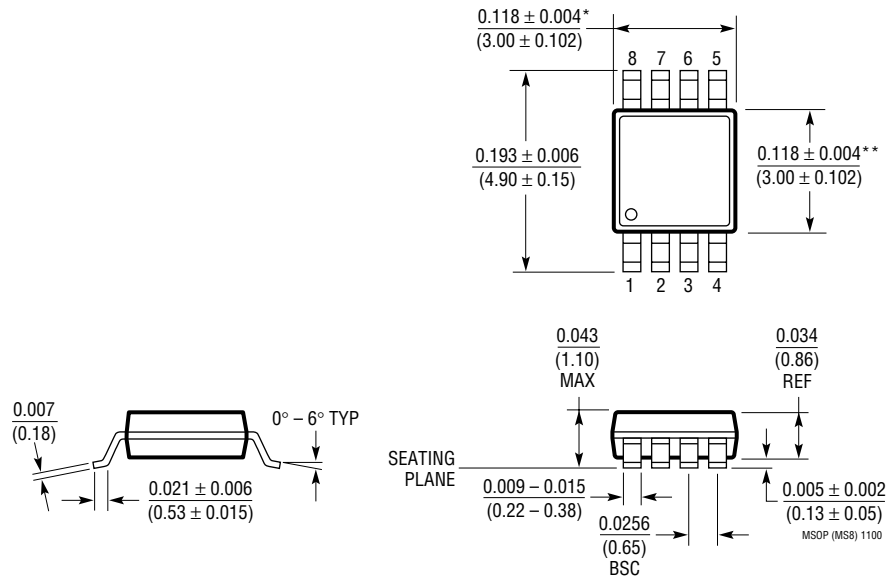

Figure 8. LTC1957 Low Frequency AC Model

**PACKAGE DESCRIPTION**

**MS8 Package**  
**8-Lead Plastic MSOP**  
 (Reference LTC DWG # 05-08-1660)



\* DIMENSION DOES NOT INCLUDE MOLD FLASH, PROTRUSIONS OR GATE BURRS. MOLD FLASH, PROTRUSIONS OR GATE BURRS SHALL NOT EXCEED 0.006" (0.152mm) PER SIDE

\*\* DIMENSION DOES NOT INCLUDE INTERLEAD FLASH OR PROTRUSIONS. INTERLEAD FLASH OR PROTRUSIONS SHALL NOT EXCEED 0.006" (0.152mm) PER SIDE

# PACKAGE DESCRIPTION

**MS10 Package**  
**10-Lead Plastic MSOP**  
 (Reference LTC DWG # 05-08-1661)

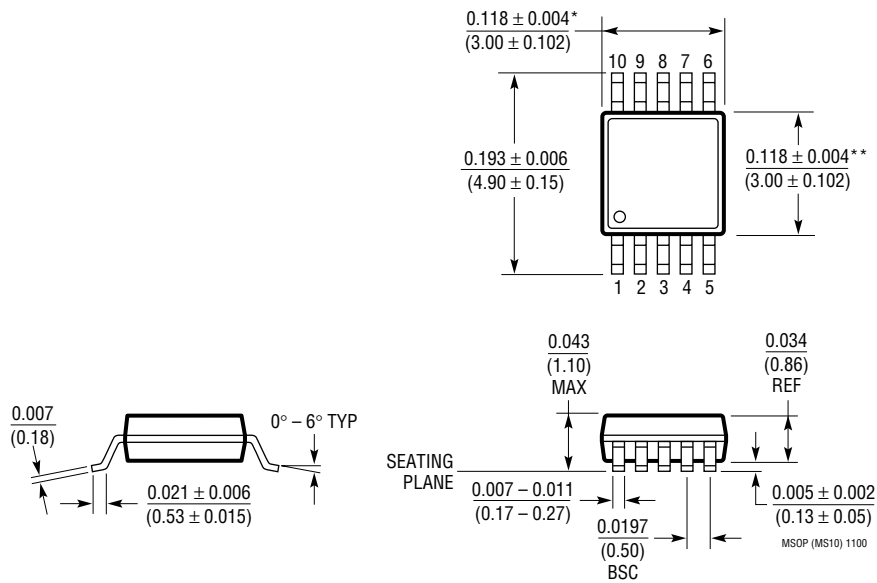

- \* DIMENSION DOES NOT INCLUDE MOLD FLASH, PROTRUSIONS OR GATE BURRS. MOLD FLASH, PROTRUSIONS OR GATE BURRS SHALL NOT EXCEED 0.006" (0.152mm) PER SIDE
- \*\* DIMENSION DOES NOT INCLUDE INTERLEAD FLASH OR PROTRUSIONS. INTERLEAD FLASH OR PROTRUSIONS SHALL NOT EXCEED 0.006" (0.152mm) PER SIDE

## TYPICAL APPLICATION

### Single Band Cellular Telephone Transmitter

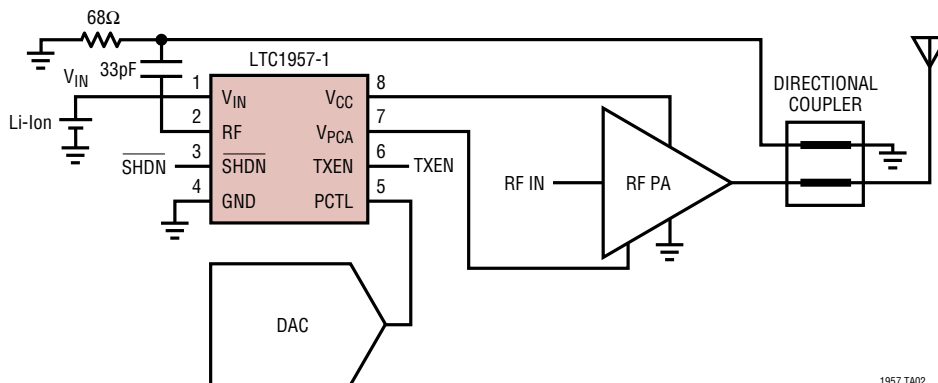

1957 TA02

### Dual Band Cellular Telephone Transmitter Without Current Limiting

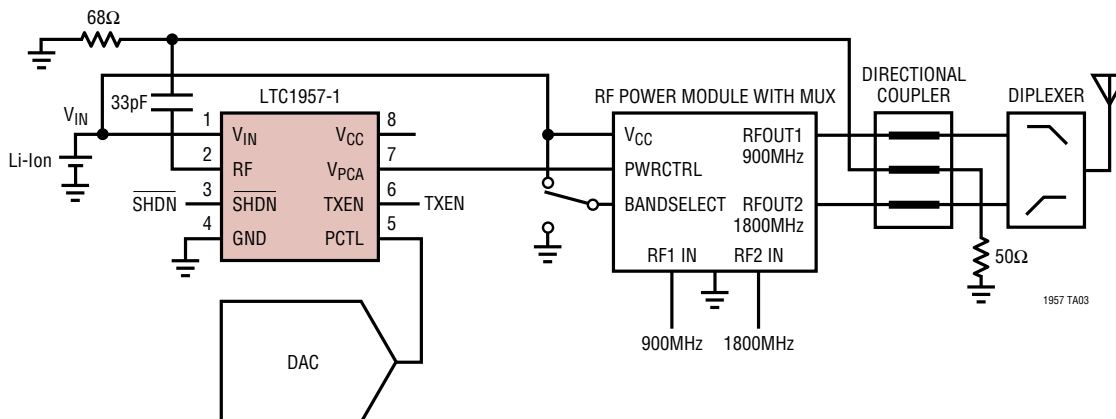

1957 TA03

## RELATED PARTS

PART NUMBER	DESCRIPTION	COMMENTS
LTC1261	Regulated Inductorless Voltage Inverter	Regulated -5V from 3V, REG Pin Indicates Regulation, Up to 15mA, Micropower
LTC1550/LTC1551	Low Noise Inductorless Voltage Inverter	Regulated Output, <1mV <sub>P-P</sub> Ripple, 900kHz
LTC1730	Li-Ion Pulse Charger	Complete Pulse Charger for 1-Cell Li-Ion Battery
LTC1732	Li-Ion Linear Charger	Complete Linear Charger for 1- and 2-Cell Li-Ion Battery
LTC1734	ThinSOT™ Li-Ion Linear Charger	Only Two External Components, Allows Charge Current Monitoring for Termination
LTC1758-1/LTC1758-2	RF Power Controllers	Single/Dual Channel RF Power Controllers (Lower Bandwidth Version of LTC1957-1/LTC1957-2)
LT®1761	ThinSOT LDO	I <sub>OUT</sub> = 100mA, Low Noise: 20μV <sub>RMS</sub>
LTC3200/LTC3200-5	Low Noise, Regulated Charge Pump	2MHz Constant Frequency, I <sub>OUT</sub> = 100mA, 2.7V ≤ V <sub>IN</sub> ≤ 4.5V, ThinSOT and MSOP Packages

ThinSOT is a trademark of Linear Technology Corporation.