

## FEATURES

- Independently Monitors Two -48V Supplies for
  - Undervoltage Faults:  $-38.5V \pm 1V_{MAX}$
  - Overvoltage Faults:  $-70V \pm 1.5V_{MAX}$
- Accurately Detects Undervoltage Fault Recovery:  $-43V \pm 0.5V_{MAX}$
- Monitors Two External Fuses
- Operates from -10V to -80V
- Tolerates DC Faults to -100V
- Tolerates Accidental Supply Reversal to 100V
- Withstands Transient Voltages Up to 200V/-200V
- Small Footprint: 8-Lead MSOP Package
- Requires No Precision External Components
- Specified from -40°C to 85°C

## APPLICATIONS

- Telecom Backplanes or Switch Cards
- Networking Backplanes or Switch Cards
- High Voltage Fuse Monitoring

## DESCRIPTION

The LTC<sup>®</sup>1921 monitors two independent -48V supplies, including their fuses, and drives up to three optoisolators to indicate status, in accordance with standard backplane specifications. Requiring only three noncritical resistors and optoisolators, the LTC1921 replaces multiple voltage comparators, a voltage reference and several precision resistors.

The monitor features dual supply overvoltage and undervoltage detection circuits. The preset trip thresholds include overvoltage, undervoltage and undervoltage recovery that are guaranteed over temperature and meet or exceed common backplane specifications. Additional built-in circuitry detects the condition of supply fuses. Overvoltage and undervoltage detectors ignore fast supply transients, eliminating false detection. The LTC1921 operates from -10V to -80V with a typical power dissipation of less than 10mW.

The LTC1921 is available in an 8-pin MSOP package.

 LTC and LT are registered trademarks of Linear Technology Corporation.

## TYPICAL APPLICATION

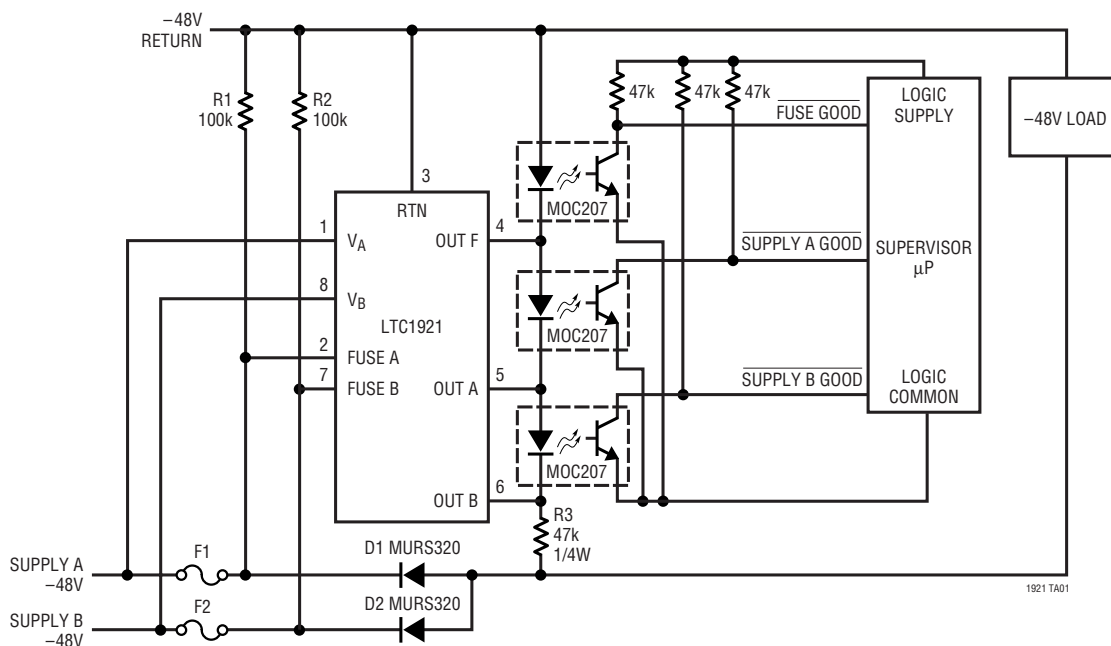

## ABSOLUTE MAXIMUM RATINGS

(Note 1) All voltages referred to RTN

Supply Voltage

( $V_A$ ,  $V_B$ , FUSE A, FUSE B) ..... 100V to -100V

Transient Voltage ( $V_A$ ,  $V_B$ , FUSE A, FUSE B)

(Note 2) ..... 0V to 200V

Transient Voltage ( $V_A$ ,  $V_B$ , FUSE A, FUSE B)

(Note 2) ..... 0V to -200V

OUT A, OUT B, OUT F Pins ..... 0.3V to -8V

Maximum Junction Temperature ..... 150°C

Operating Temperature Range

LTC1921CMS8 ..... 0°C to 70°C

LTC1921IMS8 ..... -40°C to 85°C

Storage Temperature Range ..... -65°C to 150°C

Lead Temperature (Soldering, 10 sec) ..... 300°C

## PACKAGE/ORDER INFORMATION

	ORDER PART NUMBER
	LTC1921CMS8 LTC1921IMS8
	MS8 PART MARKING
	LTZV LTZU

Consult LTC Marketing for parts specified with wider operating temperature ranges.

## ELECTRICAL CHARACTERISTICS

The ● denotes specifications which apply over the full operating temperature range, otherwise specifications are at  $T_A = 25^\circ\text{C}$ . (Note 3)  $\text{RTN} = 0\text{V}$ ,  $V_A = -48\text{V}$ ,  $V_B = -48\text{V}$ , FUSE A = -48V, FUSE B = -48V, unless otherwise noted.

PARAMETER	CONDITIONS	MIN	TYP	MAX	UNITS
<b>Power Supply</b>					
Supply Voltage Range ( $\text{RTN} - V_A$ , $\text{RTN} - V_B$ )		● 10		80	V
Supply Current ( $I_A + I_B$ )				-160	$\mu\text{A}$
		●		-250	$\mu\text{A}$
				-300	$\mu\text{A}$
<b>Supply Monitor</b>					
Undervoltage Threshold		● -39.5		-37.5	V
Undervoltage Recovery Threshold		● -43.5		-42.5	V
Overshoot Threshold		● -71.5		-68.5	V
Overshoot Threshold Hysteresis		● 1		1.6	V
<b>Fuse Monitor</b>					
Input Resistance, FUSE A, FUSE B				11	$\text{M}\Omega$
Fuse Comparison Threshold $ V_{\text{FUSEA}} - V_A $ , $ V_{\text{FUSEB}} - V_B $				2.5	V
	LTC1921C	● 0.9		4.5	V
	LTC1921I	● 0.5		4.5	V
<b>Output</b>					
Propagation Delay	$C_{\text{OUT}} = 100\text{pF}$ , Overdrive = 1V			220	$\mu\text{s}$
Output Switch Resistance, OUT F, OUT A, OUT B	$V_A = V_B = -35\text{V}$ , $V_{\text{FUSEA}} = V_{\text{FUSEB}} = 0\text{V}$ $I_{\text{OUT}} = 10\text{mA}$	●		25	$\Omega$
				50	$\Omega$
Output Switch Off Leakage				500	$\text{pA}$
Output Switch Resistance in Undervoltage Lockout, OUT F, OUT A, OUT B	$V_A = V_B = -10\text{V}$ , $I_{\text{OUT}} = 10\text{mA}$ $V_A = -10\text{V}$ , $V_B = 0\text{V}$ , $I_{\text{OUT}} = 10\text{mA}$ $V_A = 0\text{V}$ , $V_B = -10\text{V}$ , $I_{\text{OUT}} = 10\text{mA}$	●		60	$\Omega$
		●		80	$\Omega$
		●		80	$\Omega$

**Note 1:** Absolute Maximum Ratings are those values beyond which the life of a device may be impaired.

**Note 2:** Transient voltage for less than 10 $\mu\text{s}$ . This parameter is not 100% tested. Voltage should not exceed 200V between any two pins.

**Note 3:** All currents into device pins are positive; all currents out of device pins are negative. All voltages are referenced to RTN unless otherwise specified.

# TYPICAL PERFORMANCE CHARACTERISTICS

Supply Current vs Supply Voltage

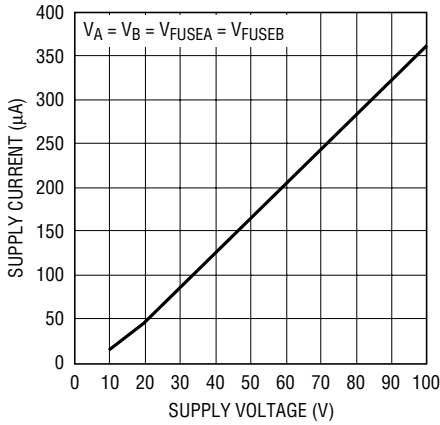

1921 G01

Supply Current vs Temperature

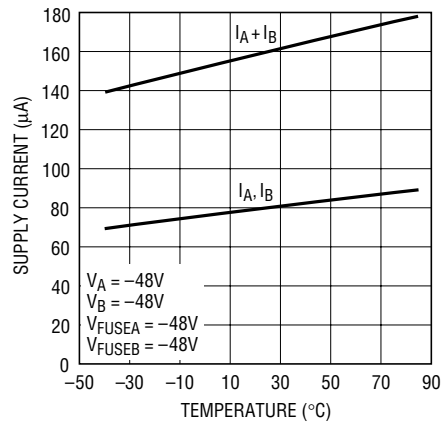

1921 G02

Undervoltage Threshold vs Temperature

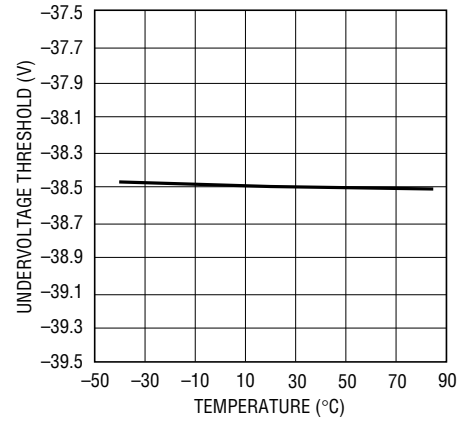

1921 G04

Undervoltage Recovery Threshold vs Temperature

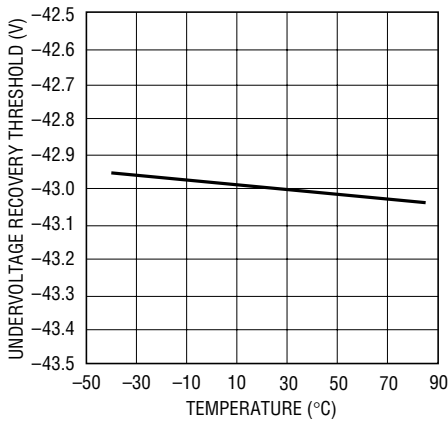

1921 G05

Overvoltage Threshold vs Temperature

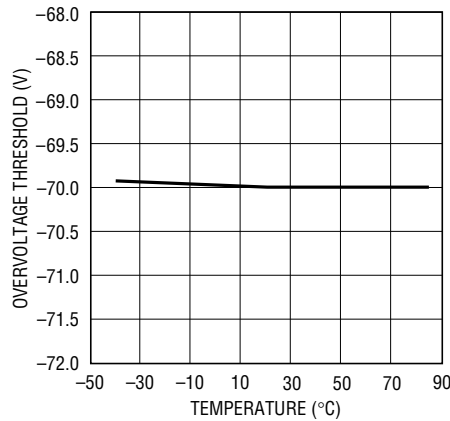

1921 G06

Overvoltage Hysteresis vs Temperature

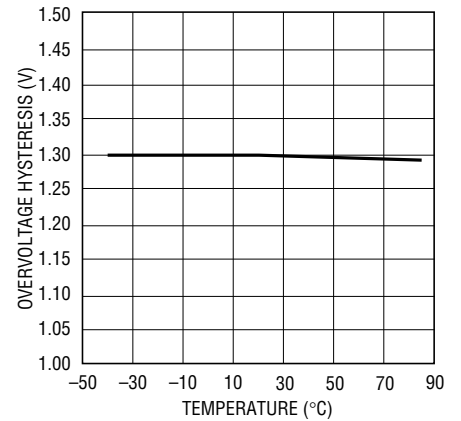

1921 G07

Fuse Window Positive Threshold vs Temperature

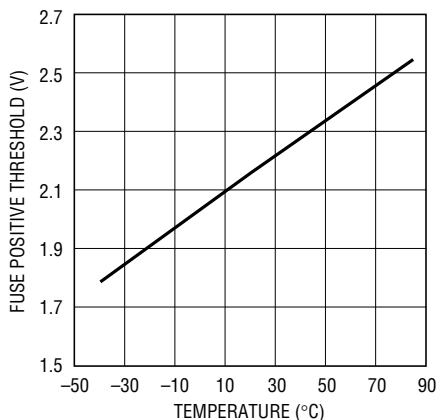

1921 G08

Fuse Window Negative Threshold vs Temperature

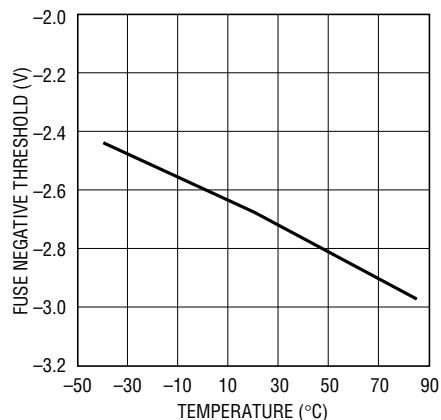

1921 G09

Output  $R_{DS(ON)}$  vs Temperature

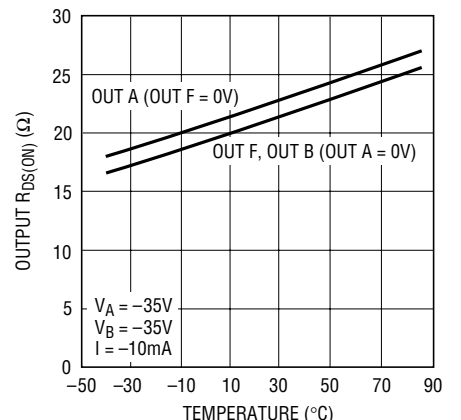

1921 G03

## TYPICAL PERFORMANCE CHARACTERISTICS

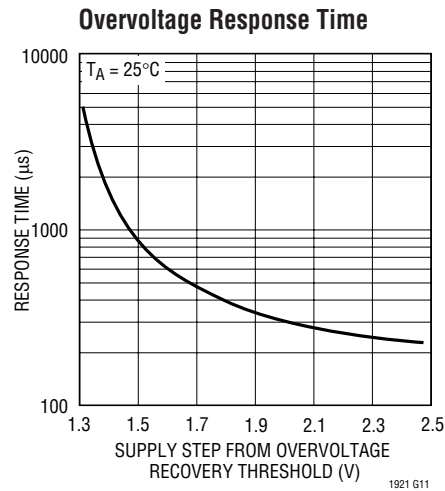
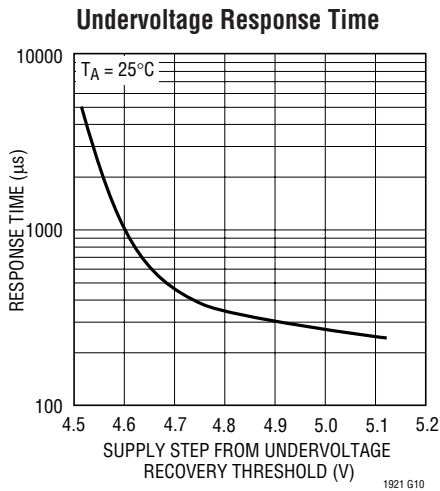

## PIN FUNCTIONS

**V<sub>A</sub> (Pin 1):** Supply to be Monitored. The voltage at this pin is compared to the valid supply voltage window and the result is output at OUT A (Pin 5). Supply current is drawn from this pin as well as from V<sub>B</sub> (Pin 8).

**FUSE A (Pin 2):** This pin monitors the state of a fuse by comparing the voltage at this pin to the voltage at V<sub>A</sub> (Pin 1). The result is output at OUT F (Pin 4).

**RTN (Pin 3):** Supply Return Reference. This pin must be at an equal or higher potential than the other pins and should be wired to the –48V return.

**OUT F (Pin 4):** This pin indicates the state of the external fuses by ORing the comparisons made to the FUSE A and FUSE B pins. If  $V_{\text{FUSEA}} \cong V_A$  ( $V_{\text{FUSEA}}$  is within the specified window around  $V_A$ ) and  $V_{\text{FUSEB}} \cong V_B$ , then OUT F will exhibit a high internal impedance to the RTN pin. If  $V_{\text{FUSEA}} \neq V_A$  or  $V_{\text{FUSEB}} \neq V_B$ , then OUT F is shorted internally to the RTN pin and can shunt enough current to turn off an optocoupler or LED wired between these pins. OUT F should be clamped externally so that it cannot be driven more than 8V below RTN. This is done automatically by the optocoupler or LED diodes shown in the application circuits.

**OUT A (Pin 5):** Indicates the State of V<sub>A</sub>. If V<sub>A</sub> is within the specified voltage window (neither undervoltage nor overvoltage), OUT A will exhibit a high internal impedance to the

OUT F pin. If V<sub>A</sub> is outside the specified overvoltage or undervoltage limits, then OUT A is shorted internally to the OUT F pin and can shunt enough current to turn off an optocoupler or LED wired between these pins. OUT A should be clamped externally so that it cannot be driven more than 8V below RTN. This is done automatically by the optocoupler or LED diodes shown in the application circuits.

**OUT B (Pin 6):** Indicates the State of V<sub>B</sub>. If V<sub>B</sub> is within the specified voltage window (neither undervoltage nor overvoltage), OUT B will exhibit a high internal impedance to the OUT A pin. If V<sub>B</sub> is outside the specified overvoltage or undervoltage limits, then OUT B is shorted internally to the OUT A pin and can shunt enough current to turn off an optocoupler or LED wired between these pins. OUT B should be clamped externally so that it cannot be driven more than 8V below RTN. This is done automatically by the optocoupler or LED diodes shown in the application circuits.

**FUSE B (Pin 7):** This pin monitors the state of a fuse by comparing the voltage at this pin to the voltage at V<sub>B</sub> (Pin 8). The result is output at OUT F (Pin 4).

**V<sub>B</sub> (Pin 8):** Supply to be Monitored. The voltage at this pin is compared to the valid supply voltage window and the result is output at OUT B (Pin 6). Supply current is drawn from this pin as well as from V<sub>A</sub> (Pin 1).

**BLOCK DIAGRAM**

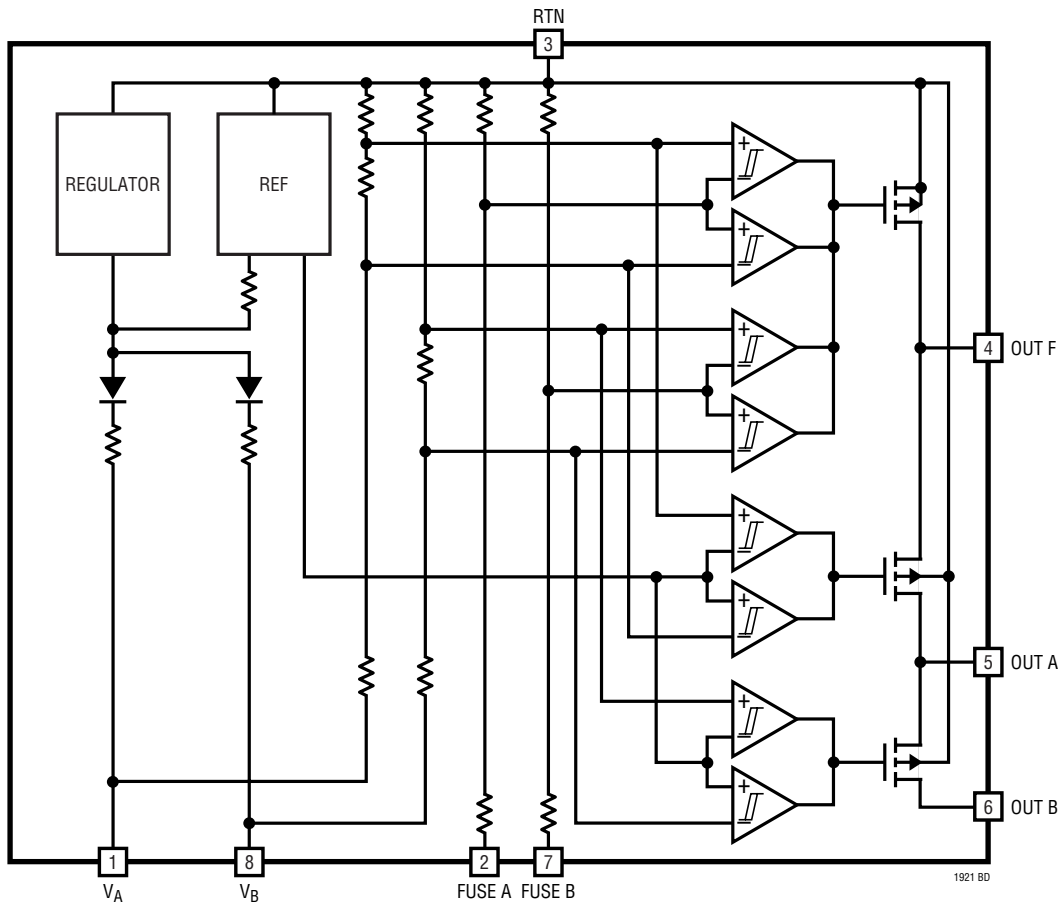

## APPLICATIONS INFORMATION

### Supply Monitoring

The LTC1921 is designed to monitor dual  $-48\text{V}$  power supplies. This is accomplished with precision window comparators and an accurate bandgap reference, as well as internal level shifting circuitry. The comparators are preset to standard voltage thresholds in order to accurately verify the status of each supply. These comparators also include precision hysteresis which allows accurate determination of voltage recovery. Status of the two supplies are indicated by the OUT A and OUT B pins.

The supply window comparison works in a straightforward way (Figure 1). As long as each supply magnitude remains in the valid supply window ( $38.5\text{V}$  to  $70\text{V}$ ), the outputs will indicate a valid supply condition by exhibiting a high internal impedance. If a supply magnitude falls below the undervoltage threshold ( $38.5\text{V}$ ), then its respective output will short internally (OUT A to OUT F or OUT B to OUT A) until that supply reaches the undervoltage recovery threshold, which is preset to  $-43\text{V}$ . At this time, the output will return to a high impedance state. If a supply magnitude rises above the overvoltage threshold ( $70\text{V}$ ), then its respective output will short internally, just as with an undervoltage condition. The output will return to its nominal state when the supply overcomes the overvoltage hysteresis.

Monitoring for each supply,  $V_A$  and  $V_B$ , is independent of the condition of the other supply. The LTC1921 can be powered equally from either  $V_A$ ,  $V_B$  or both supplies. This allows the LTC1921 to provide correct information at its outputs as long as at least one supply is functional, whether or not the fuses are intact (see Figure 2).

### Undervoltage Lockout

If both supplies are active and their magnitude falls below  $13\text{V}$ , or if only one supply is active and its magnitude falls below  $19\text{V}$ , the LTC1921 will lock all outputs into a fault condition by closing all three output switches. This state will be held until one supply magnitude is driven above  $19\text{V}$  or both are driven above  $13\text{V}$ .

### Fuse Monitoring

In addition to monitoring two supplies, the LTC1921 can monitor the condition of two supply fuses via the FUSE A (Pin 2) and FUSE B (Pin 7) inputs. Fuse monitoring is accomplished by comparing the potential at FUSE A to the potential at supply  $V_A$  and comparing the potential at FUSE B to the potential at supply  $V_B$ . If  $V_{\text{FUSEA}}$  is within the specified voltage window around  $V_A$  and  $V_{\text{FUSEB}}$  is within the specified voltage window around  $V_B$ , the OUT F pin will indicate that the fuses are intact by exhibiting a high

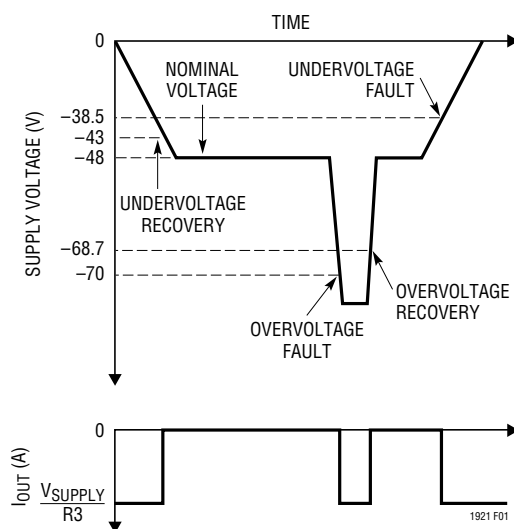

Figure 1. Supply Comparison

## APPLICATIONS INFORMATION

internal impedance to the return (RTN) pin. The application must be designed so that an open fuse condition will force the fuse input (FUSE A or FUSE B) to be outside the specified window around the supply pins, such as with a weak pull-up resistor to RTN, so that the LTC1921 can properly indicate a fault at OUT F. If supply diodes that exhibit high reverse leakage, such as Schottky diodes, are used, then the values of the pull-up resistors must be reduced accordingly.

The FUSE A and FUSE B pins may also be used in conjunction with  $V_A$  and  $V_B$  for simple window comparison, provided that one of the circuit nodes to be compared can provide the small amount of supply current required to bias the IC. The LTC1921 is ideally suited for comparison functions in a circuit where only high supply voltages are available.

### Output Pins

The output pins in the LTC1921 are designed to shunt external optocoupler diodes or LEDs during a supply or fuse fault condition. Up to three diodes may be used in

series, one for each output. In this configuration (Figure 2), a diode connected between OUT F and RTN will indicate the condition of both fuses. A diode connected between OUT A and OUT F will indicate the condition of supply A ( $V_A$ ) and a diode connected between OUT B and OUT A will indicate the condition of supply B ( $V_B$ ). A resistor connected from OUT B to the negative supply is required to bias the diodes. The LTC1921 is designed to allow the current from this resistor to flow through the diodes during normal supply conditions and intact fuses, and will shunt this current away from the proper diodes during a fault condition. These diodes will further clamp the output pin potentials to RTN in order to keep the outputs within rated voltages. If LEDs are used instead of optocouplers, they should be green since they will be lit when the supplies are within the proper voltage range.

The LTC1921 may be connected in such a way as to OR various outputs to allow the use of fewer optocouplers or LEDs (Figures 3a and 3b). One and two diode circuits are shown.

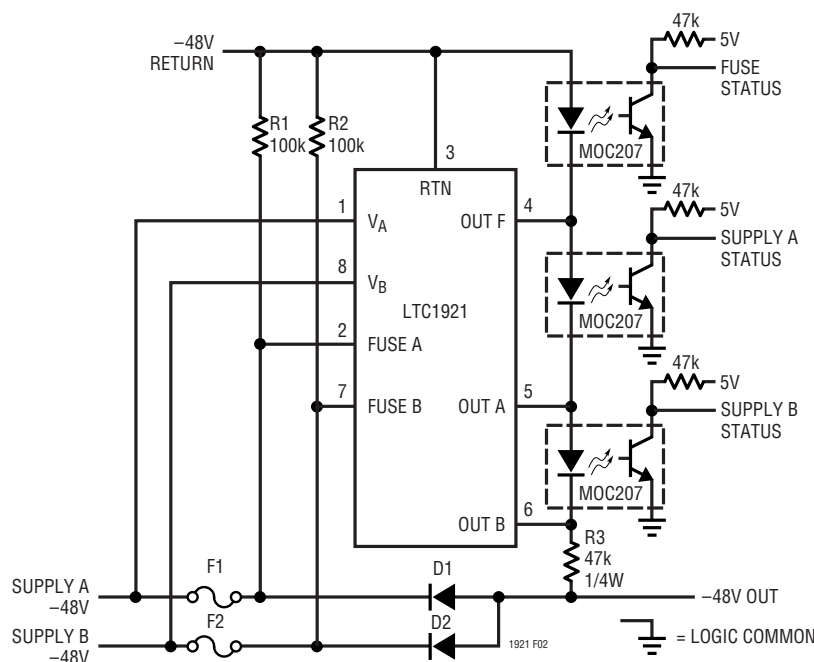

$V_A$	$V_B$	SUPPLY A STATUS	SUPPLY B STATUS
OK	OK	0	0
OK	UV OR OV	0	1
UV OR OV	OK	1	0
UV OR OV	UV OR OV	1	1

OK: WITHIN SPECIFICATION  
 OV: OVERVOLTAGE  
 UV: UNDERVOLTAGE

FUSE A	FUSE B	FUSE STATUS
$= V_A$	$= V_B$	0
$= V_A$	$\neq V_B$	1
$\neq V_A$	$= V_B$	1
$\neq V_A$	$\neq V_B$	1*

0: LED/PHOTODIODE ON  
 1: LED/PHOTODIODE OFF  
 \*IF BOTH FUSES (F1 AND F2) ARE OPEN,  
 ALL STATUS OUTPUTS WILL BE HIGH  
 SINCE R3 WILL NOT BE POWERED

Figure 2

## APPLICATIONS INFORMATION

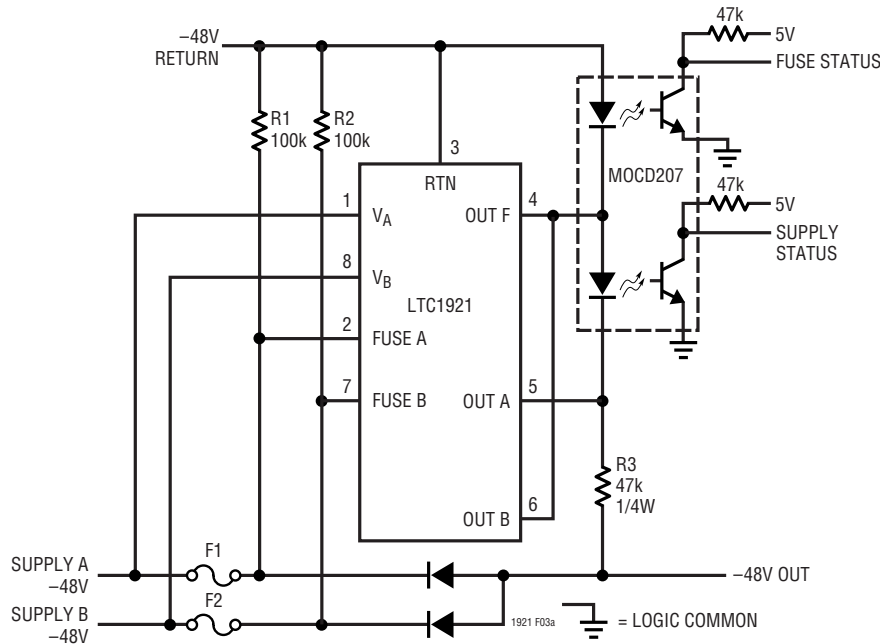

V <sub>A</sub>	V <sub>B</sub>	SUPPLY STATUS
OK	OK	0
OK	UV OR OV	1
UV OR OV	OK	1
UV OR OV	UV OR OV	1

OK: WITHIN SPECIFICATION  
 OV: OVERVOLTAGE  
 UV: UNDERVOLTAGE

FUSE A	FUSE B	FUSE STATUS
= V <sub>A</sub>	= V <sub>B</sub>	0
= V <sub>A</sub>	≠ V <sub>B</sub>	1
≠ V <sub>A</sub>	= V <sub>B</sub>	1
≠ V <sub>A</sub>	≠ V <sub>B</sub>	1*

0: LED/PHOTODIODE ON  
 1: LED/PHOTODIODE OFF  
 \*IF BOTH FUSES (F1 AND F2) ARE OPEN,  
 ALL STATUS OUTPUTS WILL BE HIGH  
 SINCE R3 WILL NOT BE POWERED

Figure 3a. Combined Supply Status

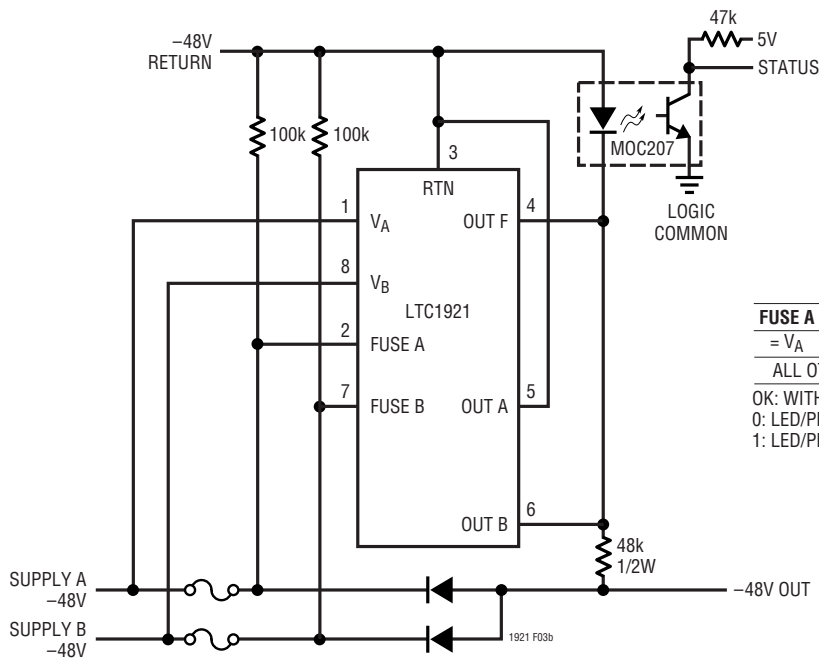

FUSE A	FUSE B	V <sub>A</sub>	V <sub>B</sub>	STATUS
= V <sub>A</sub>	= V <sub>B</sub>	OK	OK	0
ALL OTHER CONDITIONS				1

OK: WITHIN SPECIFICATION  
 0: LED/PHOTODIODE ON  
 1: LED/PHOTODIODE OFF

Figure 3b. All Outputs Combined



TYPICAL APPLICATIONS

Complete -48V Telecom Supply Monitor and Hot Swap™ Controller

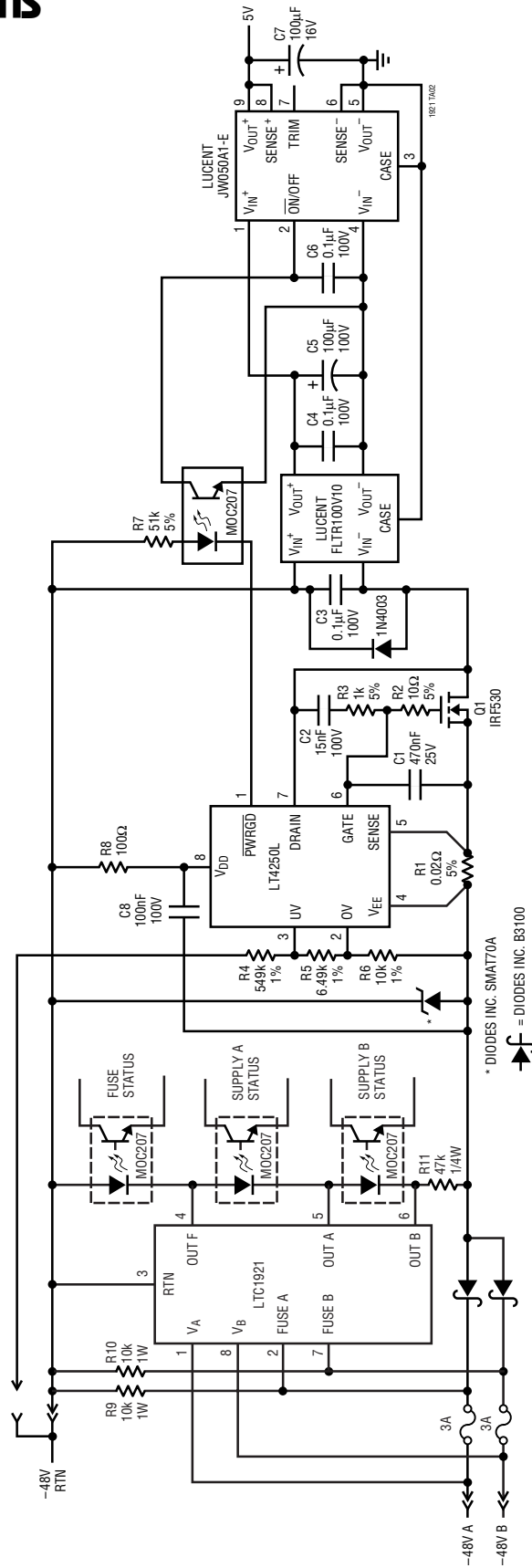

\* DIODES INC. SMAT70A  
 = DIODES INC. B3100

**TYPICAL APPLICATIONS**

**Single 48V Supply Monitor**

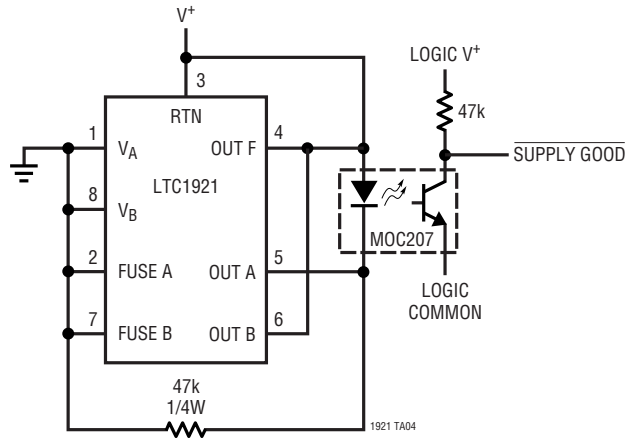

**Single -48V Supply Monitor**

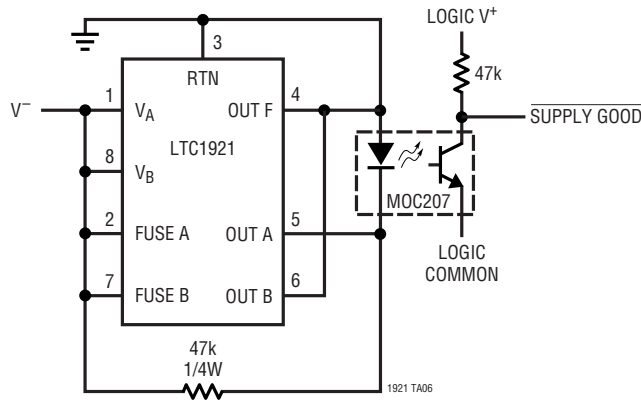

# PACKAGE DESCRIPTION

**MS8 Package**  
**8-Lead Plastic MSOP**  
 (Reference LTC DWG # 05-08-1660)

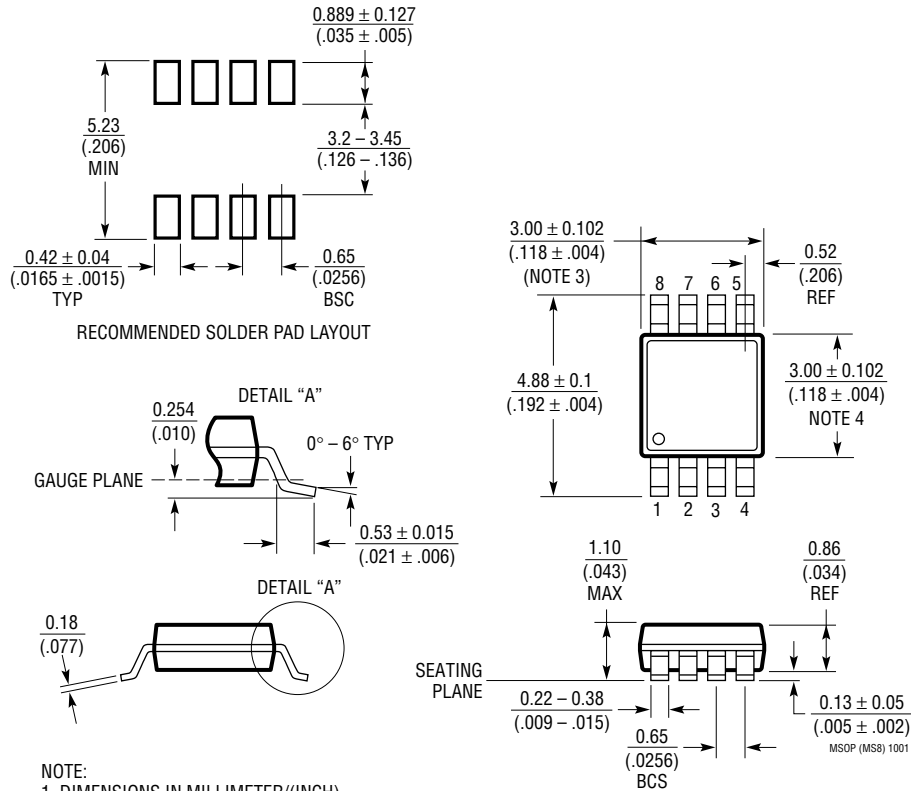

- NOTE:
1. DIMENSIONS IN MILLIMETER/(INCH)
  2. DRAWING NOT TO SCALE
  3. DIMENSION DOES NOT INCLUDE MOLD FLASH, PROTRUSIONS OR GATE BURRS.  
MOLD FLASH, PROTRUSIONS OR GATE BURRS SHALL NOT EXCEED 0.152mm (.006") PER SIDE
  4. DIMENSION DOES NOT INCLUDE INTERLEAD FLASH OR PROTRUSIONS.  
INTERLEAD FLASH OR PROTRUSIONS SHALL NOT EXCEED 0.152mm (.006") PER SIDE
  5. LEAD COPLANARITY (BOTTOM OF LEADS AFTER FORMING) SHALL BE 0.102mm (.004") MAX

## TYPICAL APPLICATION

Voltage and Fuse Monitor with LED Outputs

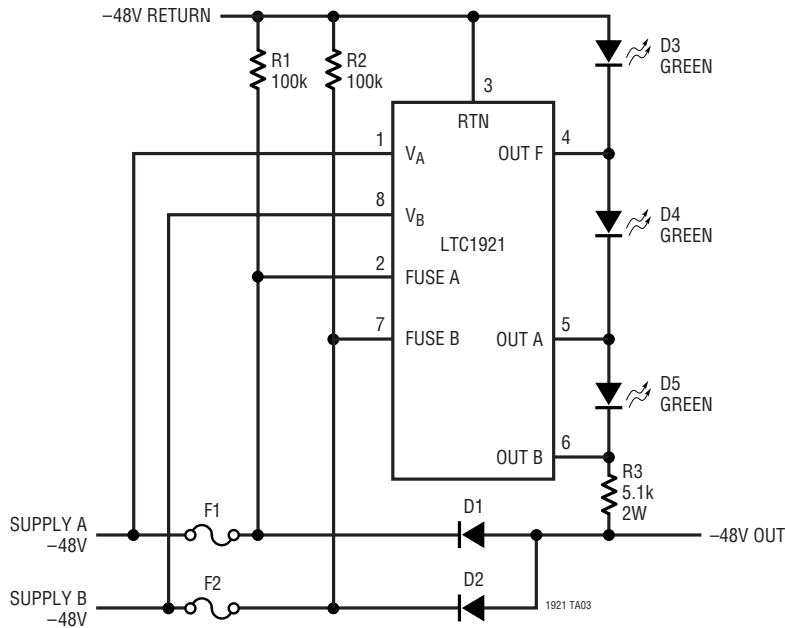

## RELATED PARTS

PART NUMBER	DESCRIPTION	COMMENTS
LT4250	-48V Hot Swap Controller in SO-8 Package	Active Current Limiting, Supplies from -20V to -80V
LTC4251	-48V Hot Swap Controller in SOT-23 Package	Fast Active Current Limiting, Supplies from -15V (Floating)
LTC4252	-48V Hot Swap Controller in MSOP Package	Fast Active Current Limiting, Floating Supply, PWRGD Output
LTC4253	-48V Hot Swap Controller with Sequencer	Similar to LTC4252, Sequences Three DC/DC Converters