

Constant Frequency Current Mode Step-Down DC/DC Controller in SOT-23

FEATURES

- Burst Mode® Operation Disabled for Lower Output Ripple at Light Loads
- High Efficiency: Up to 94%
- High Output Currents Easily Achieved
- Wide V_{IN} Range: 2.5V to 9.8V
- Constant Frequency 550kHz Operation
- Low Dropout: 100% Duty Cycle
- Output Voltage Down to 0.8V
- Current Mode Operation for Excellent Line and Load Transient Response
- Shutdown Mode Draws Only 8 μ A Supply Current
- Tiny 6-Lead TSOT-23 Package

APPLICATIONS

- One or Two Lithium-Ion-Powered Applications
- Cellular Telephones
- Wireless Devices
- Portable Computers
- Distributed 3.3V, 2.5V or 1.8V Power Systems

DESCRIPTION

The LTC®1772B is a constant frequency current mode step-down DC/DC controller providing excellent AC and DC load and line regulation. The device incorporates an accurate undervoltage lockout feature that shuts down the LTC1772B when the input voltage falls below 2.0V.

The LTC1772B provides a $\pm 2.5\%$ output voltage accuracy and consumes only 270 μ A of quiescent current. In shutdown, the device draws a mere 8 μ A.

To further maximize the life of a battery source, the external P-channel MOSFET is turned on continuously in dropout (100% duty cycle). High constant operating frequency of 550kHz allows the use of a small external inductor.

The LTC1772B is available in a small footprint 6-lead TSOT-23.

For a Burst Mode operation enabled version of the LTC1772B, please refer to the LTC1772 data sheet.

LT, LT, LTC, LTM and Burst Mode are registered trademarks of Linear Technology Corporation. All other trademarks are the property of their respective owners.

TYPICAL APPLICATION

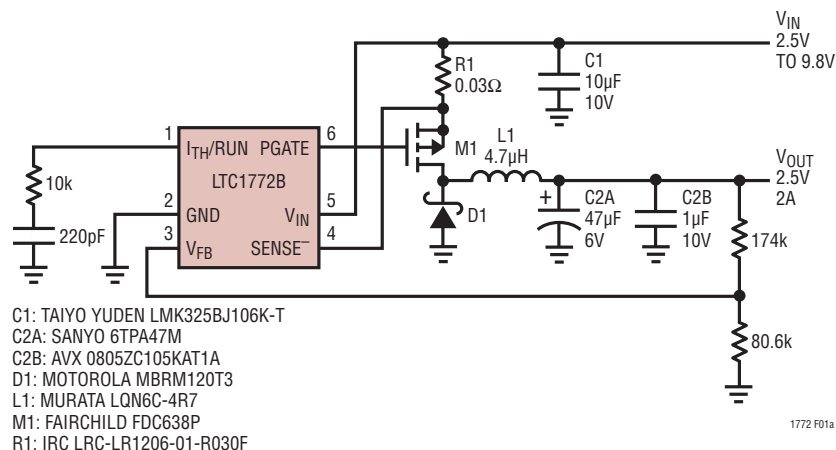
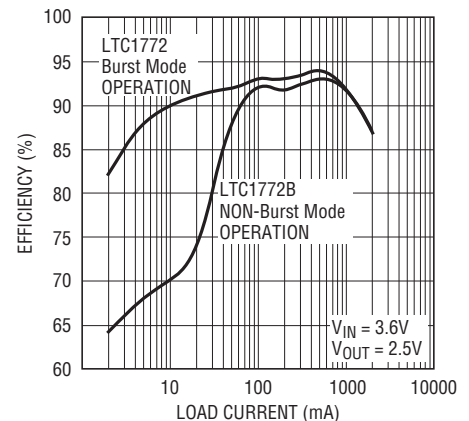

Figure 1. High Efficiency, High Output Current 2.5V/2A Regulator

Efficiency vs Load Current*



*OUTPUT RIPPLE WAVEFORMS FOR THE CIRCUIT OF FIGURE 1 APPEAR IN FIGURE 2.

1772 F01b

LTC1772B

ABSOLUTE MAXIMUM RATINGS

(Note 1)

Input Supply Voltage (V_{IN})	-0.3V to 10V
SENSE ⁻ , PGATE Voltages	-0.3V to ($V_{IN} + 0.3V$)
V_{FB} , I_{TH}/RUN Voltages	-0.3V to 2.4V
PGATE Peak Output Current (< 10 μ s)	1A
Storage Ambient Temperature Range	-65°C to 150°C
Operating Temperature Range (Note 2)	-40°C to 85°C
Junction Temperature (Note 3)	150°C
Lead Temperature (Soldering, 10 sec)	300°C

PIN CONFIGURATION

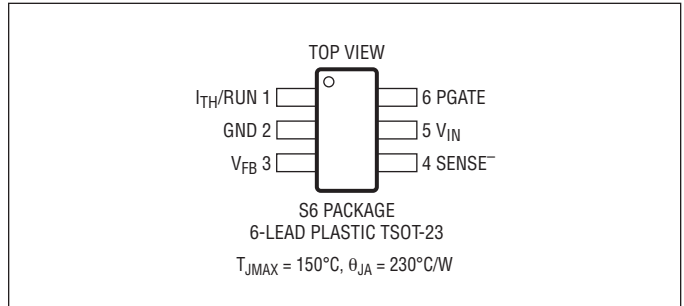

ORDER INFORMATION

LEAD FREE FINISH	TAPE AND REEL	PART MARKING*	PACKAGE DESCRIPTION	TEMPERATURE RANGE
LTC1772BES6#PBF	LTC1772BES6#TRPBF	LTVU	6-Lead Plastic TSOT Package	-40°C to 85°C
LTC1772BIS6#PBF	LTC1772BIS6#TRPBF	LTVU	6-Lead Plastic TSOT Package	-40°C to 85°C
LEAD BASED FINISH	TAPE AND REEL	PART MARKING*	PACKAGE DESCRIPTION	TEMPERATURE RANGE
LTC1772BES6	LTC1772BES6#TR	LTVU	6-Lead Plastic TSOT Package	-40°C to 85°C
LTC1772BIS6	LTC1772BIS6#TR	LTVU	6-Lead Plastic TSOT Package	-40°C to 85°C

Consult LTC Marketing for parts specified with wider operating temperature ranges. *The temperature grade is identified by a label on the shipping container.

For more information on lead free part marking, go to: <http://www.linear.com/leadfree/>

For more information on tape and reel specifications, go to: <http://www.linear.com/tapeandreeel/>

ELECTRICAL CHARACTERISTICS

The ● denotes the specifications which apply over the full operating temperature range, otherwise specifications are at $T_A = 25^{\circ}C$. $V_{IN} = 4.2V$ unless otherwise specified. (Note 2)

PARAMETER	CONDITIONS	MIN	TYP	MAX	UNITS	
Input DC Supply Current	Typicals at $V_{IN} = 4.2V$ (Note 4) $2.4V \leq V_{IN} \leq 9.8V$, PGATE Logic High		270	420	μA	
		Normal Operation		8	22	μA
		Shutdown		6	10	μA
UVLO	$V_{IN} < UVLO$ Threshold					
Undervoltage Lockout Threshold	V_{IN} Falling	● 1.55	2.00	2.35	V	
	V_{IN} Rising	1.85	2.10	2.40	V	
Shutdown Threshold (at I_{TH}/RUN)		● 0.15	0.35	0.55	V	
Start-Up Current Source	$V_{ITH}/RUN = 0V$		0.25	0.5	μA	
Regulated Feedback Voltage	0°C to 70°C (Note 5) -40°C to 85°C (Note 5)	● 0.780	0.800	0.820	V	
		● 0.770	0.800	0.830	V	
Output Voltage Line Regulation	$2.4V \leq V_{IN} \leq 9.8V$ (Note 5)		0.05		mV/V	
Output Voltage Load Regulation	I_{TH}/RUN Sinking 5 μA (Note 5) I_{TH}/RUN Sourcing 5 μA (Note 5)		2.5		mV/ μA	
			2.5		mV/ μA	

1772bfa

ELECTRICAL CHARACTERISTICS

The ● denotes the specifications which apply over the full operating temperature range, otherwise specifications are at $T_A = 25^\circ\text{C}$. $V_{IN} = 4.2\text{V}$ unless otherwise specified. (Note 2)

PARAMETER	CONDITIONS	MIN	TYP	MAX	UNITS
V_{FB} Input Current	(Note 5)		10	50	nA
Overshoot Protect Threshold	Measured at V_{FB}	0.820	0.860	0.895	V
Overshoot Protect Hysteresis			20		mV
Oscillator Frequency	$V_{FB} = 0.8\text{V}$ $V_{FB} = 0\text{V}$	500	550 120	650	kHz kHz
Gate Drive Rise Time	$C_{LOAD} = 3000\text{pF}$		40		ns
Gate Drive Fall Time	$C_{LOAD} = 3000\text{pF}$		40		ns
Peak Current Sense Voltage	(Note 6)		105		mV

Note 1: Stresses beyond those listed under Absolute Maximum Ratings may cause permanent damage to the device. Exposure to any Absolute Maximum Rating condition for extended periods may affect device reliability and lifetime.

Note 2: The LTC1772BE is guaranteed to meet specifications from 0°C to 85°C . Specifications over the -40°C to 85°C operating temperature range are assured by design, characterization and correlation with statistical process controls. The LTC1772BI is guaranteed to meet specifications over the full -40°C to 85°C operating temperature range.

Note 3: T_J is calculated from the ambient temperature T_A and power dissipation P_D according to the following formula:

$$T_J = T_A + (P_D \cdot \theta_{JA}^\circ\text{C/W})$$

Note 4: Dynamic supply current is higher due to the gate charge being delivered at the switching frequency.

Note 5: The LTC1772B is tested in a feedback loop that servos V_{FB} to the output of the error amplifier.

Note 6: Peak current sense voltage is reduced dependent on duty cycle to a percentage of value as given in Figure 2.

TYPICAL PERFORMANCE CHARACTERISTICS

Reference Voltage vs Temperature

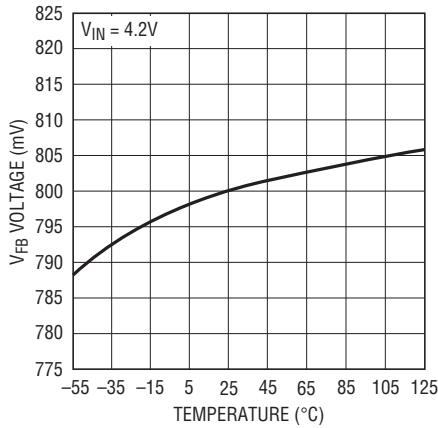

1772 G01

Normalized Oscillator Frequency vs Temperature

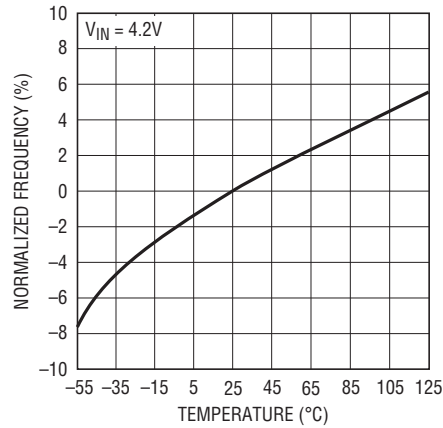

1772 G02

Undervoltage Lockout Trip Voltage vs Temperature

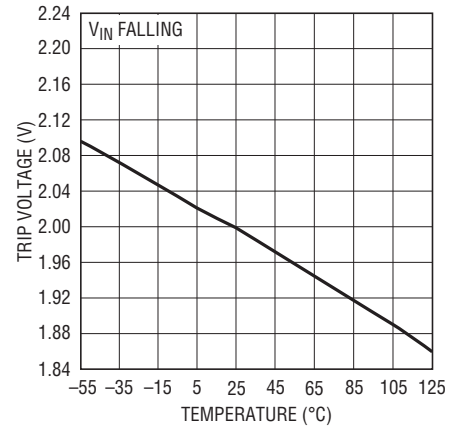

1772 G03

Maximum (V_{IN} - SENSE⁻) Voltage vs Duty Cycle

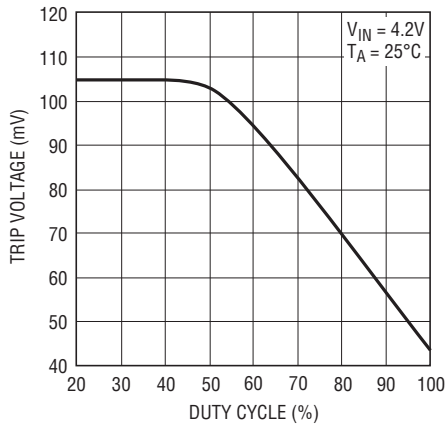

1772 G04

Shutdown Threshold vs Temperature

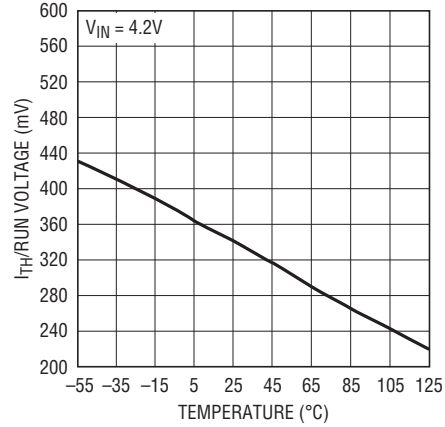

1772 G05

PIN FUNCTIONS

I_{TH}/RUN (Pin 1): This pin performs two functions. It serves as the error amplifier compensation point as well as the run control input. Nominal voltage range for this pin is 0.85V to 1.9V. Forcing this pin below 0.35V causes the device to be shut down. In shutdown all functions are disabled and the PGATE pin is held high.

GND (Pin 2): Ground Pin.

V_{FB} (Pin 3): Receives the feedback voltage from an external resistive divider across the output.

SENSE⁻ (Pin 4): The Negative Input to the Current Comparator.

V_{IN} (Pin 5): Supply Pin. Must be closely decoupled to GND Pin 2.

PGATE (Pin 6): Gate Drive for the External P-channel MOSFET. This pin swings from 0V to V_{IN} .

FUNCTIONAL DIAGRAM

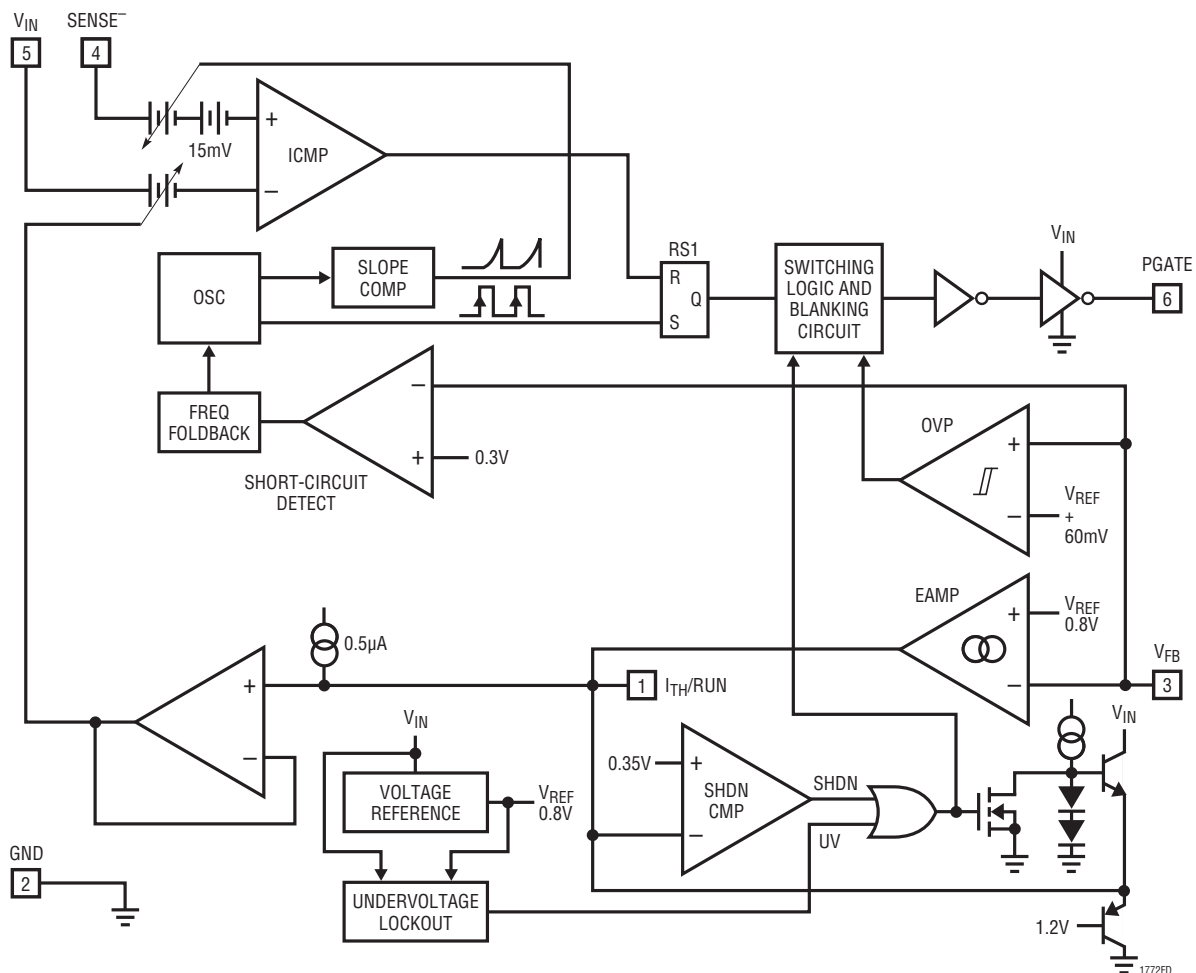

OPERATION (Refer to Functional Diagram)

Main Control Loop

The LTC1772B is a constant frequency current mode switching regulator. During normal operation, the external P-channel power MOSFET is turned on each cycle when the oscillator sets the RS latch (RS1) and turned off when the current comparator (ICMP) resets the latch. The peak inductor current at which ICMP resets the RS latch is controlled by the voltage on the I_{TH}/RUN pin, which is the output of the error amplifier EAMP. An external resistive divider connected between V_{OUT} and ground allows the EAMP to receive an output feedback voltage V_{FB}. When the load current increases, it causes a slight decrease in V_{FB} relative to the 0.8V reference, which in turn causes the I_{TH}/RUN voltage to increase until the average inductor current matches the new load current.

The main control loop is shut down by pulling the I_{TH}/RUN pin low. Releasing I_{TH}/RUN allows an internal 0.5μA current source to charge up the external compensation network. When the I_{TH}/RUN pin reaches 0.35V, the main control loop is enabled with the I_{TH}/RUN voltage then pulled up to its zero current level of approximately 0.85V. As the external compensation network continues to charge up, the corresponding output current trip level follows, allowing normal operation.

Comparator OVP guards against transient overshoots >7.5% by turning off the external P-channel power MOSFET and keeping it off until the fault is removed.

Low Load Current Operation

Under very light load current conditions, the I_{TH}/RUN pin voltage will be very close to the zero current level of 0.85V. As the load current decreases further, an internal offset at the current comparator input will assure that the current comparator remains tripped (even at zero load current) and the regulator will start to skip cycles, as it must, in order to maintain regulation. This behavior allows the regulator to maintain constant frequency down to very light loads, resulting in less low frequency noise generation over a wide load current range.

Figure 2 illustrates this result for the circuit of Figure 1 using both an LTC1772 in Burst Mode operation and an LTC1772B (non-Burst Mode operation). At an output current of 100mA, the Burst Mode operation part exhibits an output ripple of approximately 60mV_{P-P}, whereas the non-Burst Mode operation part has an output ripple of only 20mV_{P-P}. At lower output current levels, the improvement is even greater. This comes at a tradeoff of lower efficiency for the non-Burst Mode operation part (see Figure 1). Also notice the constant frequency operation of the LTC1772B, even at 5% of maximum output current.

Dropout Operation

When the input supply voltage decreases towards the output voltage, the rate of change of inductor current during the ON cycle decreases. This reduction means

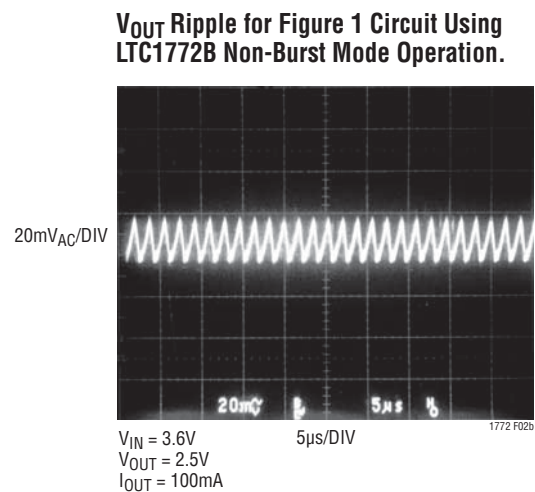
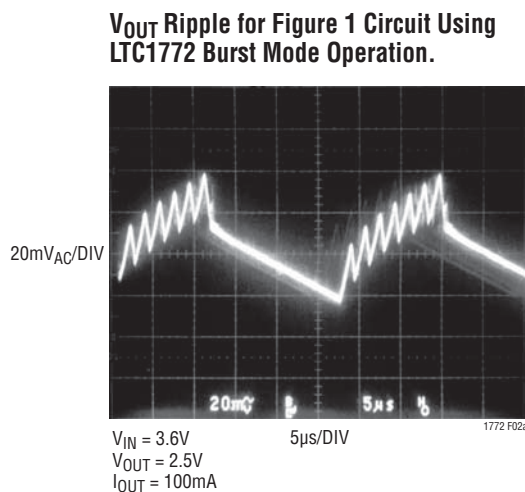

Figure 2. Output Ripple Waveforms for the Circuit of Figure 1.

OPERATION (Refer to Functional Diagram)

that the external P-channel MOSFET will remain on for more than one oscillator cycle since the inductor current has not ramped up to the threshold set by EAMP. Further reduction in input supply voltage will eventually cause the P-channel MOSFET to be turned on 100%, i.e., DC. The output voltage will then be determined by the input voltage minus the voltage drop across the MOSFET, the sense resistor and the inductor.

Undervoltage Lockout

To prevent operation of the P-channel MOSFET below safe input voltage levels, an undervoltage lockout is incorporated into the LTC1772B. When the input supply voltage drops below approximately 2.0V, the P-channel MOSFET and all circuitry is turned off except the undervoltage block, which draws only several microamperes.

Short-Circuit Protection

When the output is shorted to ground, the frequency of the oscillator will be reduced to about 120kHz. This lower frequency allows the inductor current to safely discharge, thereby preventing current runaway. The oscillator's fre-

quency will gradually increase to its designed rate when the feedback voltage again approaches 0.8V.

Overvoltage Protection

As a further protection, the overvoltage comparator in the LTC1772B will turn the external MOSFET off when the feedback voltage has risen 7.5% above the reference voltage of 0.8V. This comparator has a typical hysteresis of 20mV.

Slope Compensation and Inductor's Peak Current

The inductor's peak current is determined by:

$$I_{PK} = \frac{V_{ITH} - 0.85}{10(R_{SENSE})}$$

when the LTC1772B is operating below 40% duty cycle. However, once the duty cycle exceeds 40%, slope compensation begins and effectively reduces the peak inductor current. The amount of reduction is given by the curves in Figure 3.

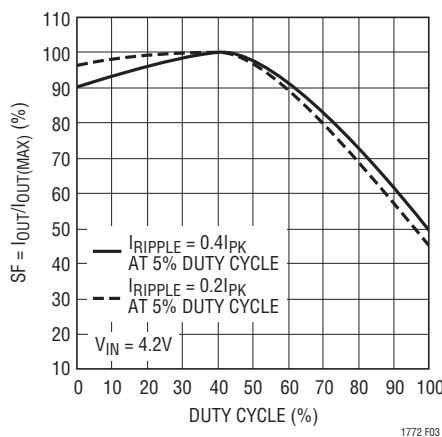

Figure 3. Maximum Output Current vs Duty Cycle

APPLICATIONS INFORMATION

The basic LTC1772B application circuit is shown in Figure 1. External component selection is driven by the load requirement and begins with the selection of L1 and R_{SENSE} (= R1). Next, the power MOSFET, M1 and the output diode D1 is selected followed by C_{IN} (= C1) and C_{OUT} (= C2).

R_{SENSE} Selection for Output Current

R_{SENSE} is chosen based on the required output current. With the current comparator monitoring the voltage developed across R_{SENSE} , the threshold of the comparator determines the inductor's peak current. The output current the LTC1772B can provide is given by:

$$I_{OUT} = \frac{0.105}{R_{SENSE}} - \frac{I_{RIPPLE}}{2}$$

where I_{RIPPLE} is the inductor peak-to-peak ripple current (see Inductor Value Calculation section).

A reasonable starting point for setting ripple current is $I_{RIPPLE} = (0.4)(I_{OUT})$. Rearranging the above equation, it becomes:

$$R_{SENSE} = \frac{0.0875}{I_{OUT}} \text{ for Duty Cycle} < 40\%$$

However, for operation that is above 40% duty cycle, slope compensation effect has to be taken into consideration to select the appropriate value to provide the required amount of current. Using Figure 3, the value of R_{SENSE} is:

$$R_{SENSE} = \frac{(0.0875)SF}{I_{OUT}(100)}$$

Inductor Value Calculation

The operating frequency and inductor selection are inter-related in that higher operating frequencies permit the use of a smaller inductor for the same amount of inductor ripple current. However, this is at the expense of efficiency due to an increase in MOSFET gate charge losses.

The inductance value also has a direct effect on ripple current. The ripple current, I_{RIPPLE} , decreases with higher inductance or frequency and increases with higher V_{IN} or V_{OUT} . The inductor's peak-to-peak ripple current is given by:

$$I_{RIPPLE} = \frac{V_{IN} - V_{OUT}}{f(L)} \left(\frac{V_{OUT} + V_D}{V_{IN} + V_D} \right)$$

where f is the operating frequency. Accepting larger values of I_{RIPPLE} allows the use of low inductances, but results in higher output voltage ripple and greater core losses. A reasonable starting point for setting ripple current is $I_{RIPPLE} = 0.4(I_{OUT(MAX)})$. Remember, the maximum I_{RIPPLE} occurs at the maximum input voltage.

The ripple current is normally set such that the inductor current is continuous down to approximately 1/4 of maximum load current. This results in:

$$I_{RIPPLE} \leq \frac{0.03}{R_{SENSE}}$$

This implies a minimum inductance of:

$$L_{MIN} = \frac{V_{IN} - V_{OUT}}{f \left(\frac{0.03}{R_{SENSE}} \right)} \left(\frac{V_{OUT} + V_D}{V_{IN} + V_D} \right)$$

(Use $V_{IN(MAX)} = V_{IN}$)

A smaller value than L_{MIN} could be used in the circuit; however, the inductor current transitioning from continuous to discontinuous will occur at a higher load current.

Power MOSFET Selection

An external P-channel power MOSFET must be selected for use with the LTC1772B. The main selection criteria for the power MOSFET are the threshold voltage $V_{GS(TH)}$ and the "on" resistance $R_{DS(ON)}$, reverse transfer capacitance C_{RSS} and total gate charge.

APPLICATIONS INFORMATION

Since the LTC1772B is designed for operation down to low input voltages, a logic level threshold MOSFET ($R_{DS(ON)}$ guaranteed at $V_{GS} = 2.5V$) is required for applications that work close to this voltage. When these MOSFETs are used, make sure that the input supply to the LTC1772B is less than the absolute maximum V_{GS} rating, typically 8V.

The required minimum $R_{DS(ON)}$ of the MOSFET is governed by its allowable power dissipation. For applications that may operate the LTC1772B in dropout, i.e., 100% duty cycle, at its worst case the required $R_{DS(ON)}$ is given by:

$$R_{DS(ON)}_{DC=100\%} = \frac{P_P}{(I_{OUT(MAX)})^2 (1 + \delta p)}$$

where P_P is the allowable power dissipation and δp is the temperature dependency of $R_{DS(ON)}$. $(1 + \delta p)$ is generally given for a MOSFET in the form of a normalized $R_{DS(ON)}$ vs temperature curve, but $\delta p = 0.005/^\circ C$ can be used as an approximation for low voltage MOSFETs.

In applications where the maximum duty cycle is less than 100% and the LTC1772B is in continuous mode, the $R_{DS(ON)}$ is governed by:

$$R_{DS(ON)} \approx \frac{P_P}{(DC) I_{OUT}^2 (1 + \delta p)}$$

where DC is the maximum operating duty cycle of the LTC1772B.

Output Diode Selection

The catch diode carries load current during the off-time. The average diode current is therefore dependent on the P-channel switch duty cycle. At high input voltages the diode conducts most of the time. As V_{IN} approaches V_{OUT} the diode conducts only a small fraction of the time. The most stressful condition for the diode is when the output is short-circuited. Under this condition the diode must safely handle I_{PEAK} at close to 100% duty cycle. Therefore, it is important to adequately specify the diode peak current and average power dissipation so as not to exceed the diode ratings.

Under normal load conditions, the average current conducted by the diode is:

$$I_D = \left(\frac{V_{IN} - V_{OUT}}{V_{IN} + V_D} \right) I_{OUT}$$

The allowable forward voltage drop in the diode is calculated from the maximum short-circuit current as:

$$V_F \approx \frac{P_D}{I_{SC(MAX)}}$$

where P_D is the allowable power dissipation and will be determined by efficiency and/or thermal requirements.

A fast switching diode must also be used to optimize efficiency. Schottky diodes are a good choice for low forward drop and fast switching times. Remember to keep lead length short and observe proper grounding (see Board Layout Checklist) to avoid ringing and increased dissipation.

C_{IN} and C_{OUT} Selection

In continuous mode, the source current of the P-channel MOSFET is a square wave of duty cycle $(V_{OUT} + V_D)/(V_{IN} + V_D)$. To prevent large voltage transients, a low ESR input capacitor sized for the maximum RMS current must be used. The maximum RMS capacitor current is given by:

$$C_{IN} \text{ Required } I_{RMS} \approx I_{MAX} \frac{[V_{OUT}(V_{IN} - V_{OUT})]^{1/2}}{V_{IN}}$$

This formula has a maximum value at $V_{IN} = 2V_{OUT}$, where $I_{RMS} = I_{OUT}/2$. This simple worst-case condition is commonly used for design because even significant deviations do not offer much relief. Note that capacitor manufacturer's ripple current ratings are often based on 2000 hours of life. This makes it advisable to further derate the capacitor, or to choose a capacitor rated at a higher temperature than required. Several capacitors may be paralleled to meet the

APPLICATIONS INFORMATION

size or height requirements in the design. Due to the high operating frequency of the LTC1772B, ceramic capacitors can also be used for C_{IN} . Always consult the manufacturer if there is any question.

The selection of C_{OUT} is driven by the required effective series resistance (ESR). Typically, once the ESR requirement is satisfied, the capacitance is adequate for filtering. The output ripple (ΔV_{OUT}) is approximated by:

$$\Delta V_{OUT} \approx I_{RIPPLE} \left(ESR + \frac{1}{4fC_{OUT}} \right)$$

where f is the operating frequency, C_{OUT} is the output capacitance and I_{RIPPLE} is the ripple current in the inductor. The output ripple is highest at maximum input voltage since ΔI_L increases with input voltage.

Manufacturers such as Nichicon, United Chemicon and Sanyo should be considered for high performance through-hole capacitors. The OS-CON semiconductor dielectric capacitor available from Sanyo has the lowest ESR (size) product of any aluminum electrolytic at a somewhat higher price. Once the ESR requirement for C_{OUT} has been met, the RMS current rating generally far exceeds the $I_{RIPPLE(P-P)}$ requirement.

Low Supply Operation

Although the LTC1772B can function down to approximately 2.0V, the maximum allowable output current is reduced when V_{IN} decreases below 3V. Figure 4 shows the amount of change as the supply is reduced down to 2V. Also shown in Figure 4 is the effect of V_{IN} on V_{REF} as V_{IN} goes below 2.3V.

Setting Output Voltage

The regulated output voltage is determined by:

$$V_{OUT} = 0.8 \left(1 + \frac{R2}{R1} \right)$$

For most applications, an 80k resistor is suggested for $R1$. To prevent stray pickup, locate resistors $R1$ and $R2$ close to LTC1772B.

Efficiency Considerations

The efficiency of a switching regulator is equal to the output power divided by the input power times 100%. It is often useful to analyze individual losses to determine what is limiting the efficiency and which change would produce the most improvement. Efficiency can be expressed as:

$$\text{Efficiency} = 100\% - (\eta_1 + \eta_2 + \eta_3 + \dots)$$

where η_1, η_2 , etc. are the individual losses as a percentage of input power.

Although all dissipative elements in the circuit produce losses, four main sources usually account for most of the losses in LTC1772B circuits: 1) LTC1772B DC bias

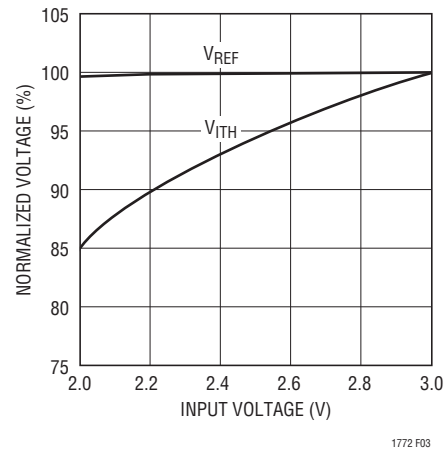

Figure 4. Line Regulation of V_{REF} and V_{ITH}

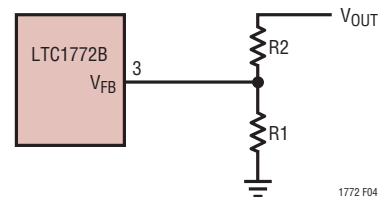

Figure 5. Setting Output Voltage

APPLICATIONS INFORMATION

current, 2) MOSFET gate charge current, 3) I^2R losses and 4) voltage drop of the output diode.

1. The V_{IN} current is the DC supply current, given in the electrical characteristics, that excludes MOSFET driver and control currents. V_{IN} current results in a small loss which increases with V_{IN} .
2. MOSFET gate charge current results from switching the gate capacitance of the power MOSFET. Each time a MOSFET gate is switched from low to high to low again, a packet of charge dQ moves from V_{IN} to ground. The resulting dQ/dt is a current out of V_{IN} which is typically much larger than the DC supply current. In continuous mode, $I_{GATECHG} = f(Qp)$.
3. I^2R losses are predicted from the DC resistances of the MOSFET, inductor and current shunt. In continuous mode the average output current flows through L but is “chopped” between the P-channel MOSFET (in series with R_{SENSE}) and the output diode. The MOSFET $R_{DS(ON)}$ plus R_{SENSE} multiplied by duty cycle can be summed with the resistances of L and R_{SENSE} to obtain I^2R losses.
4. The output diode is a major source of power loss at high currents and gets worse at high input voltages. The diode loss is calculated by multiplying the forward voltage times the diode duty cycle multiplied by the

load current. For example, assuming a duty cycle of 50% with a Schottky diode forward voltage drop of 0.4V, the loss increases from 0.5% to 8% as the load current increases from 0.5A to 2A.

5. Transition losses apply to the external MOSFET and increase at higher operating frequencies and input voltages. Transition losses can be estimated from:

$$\text{Transition Loss} = 2(V_{IN})^2 I_{O(MAX)} C_{RSS}(f)$$

Other losses including C_{IN} and C_{OUT} ESR dissipative losses, and inductor core losses, generally account for less than 2% total additional loss.

Foldback Current Limiting

As described in the Output Diode Selection, the worst-case dissipation occurs with a short-circuited output when the diode conducts the current limit value almost continuously. To prevent excessive heating in the diode, foldback current limiting can be added to reduce the current in proportion to the severity of the fault.

Foldback current limiting is implemented by adding diodes D_{FB1} and D_{FB2} between the output and the I_{TH}/RUN pin as shown in Figure 6. In a hard short ($V_{OUT} = 0V$), the current will be reduced to approximately 50% of the maximum output current.

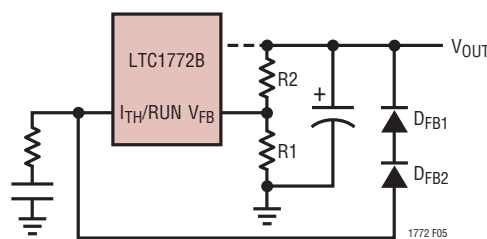

Figure 6. Foldback Current Limiting

APPLICATIONS INFORMATION

PC Board Layout Checklist

When laying out the printed circuit board, the following checklist should be used to ensure proper operation of the LTC1772B. These items are illustrated graphically in the layout diagram in Figure 7. Check the following in your layout:

1. Is the Schottky diode closely connected between ground (Pin 2) and drain of the external MOSFET?
2. Does the (+) plate of C_{IN} connect to the sense resistor as closely as possible? This capacitor provides AC current to the MOSFET.
3. Is the input decoupling capacitor ($0.1\mu\text{F}$) connected closely between V_{IN} (Pin 5) and ground (Pin 2)?
4. Connect the end of R_{SENSE} as close to V_{IN} (Pin 5) as possible. The V_{IN} pin is the SENSE^+ of the current comparator.
5. Is the trace from SENSE^- (Pin 4) to the Sense resistor kept short? Does the trace connect close to R_{SENSE} ?
6. Keep the switching node PGATE away from sensitive small signal nodes.
7. Does the V_{FB} pin connect directly to the feedback resistors? The resistive divider $R1$ and $R2$ must be connected between the (+) plate of C_{OUT} and signal ground.

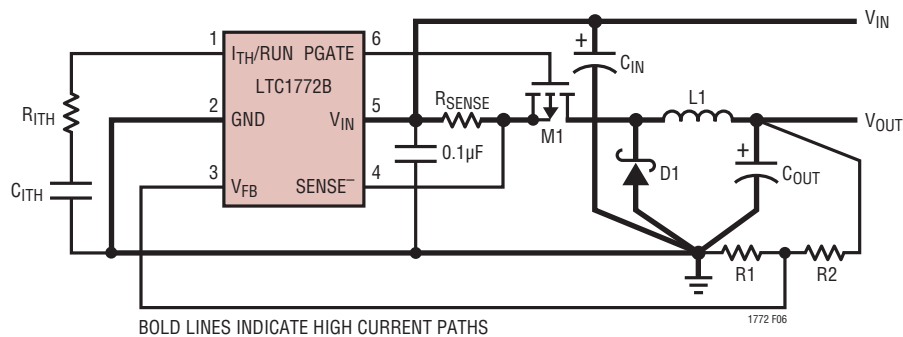
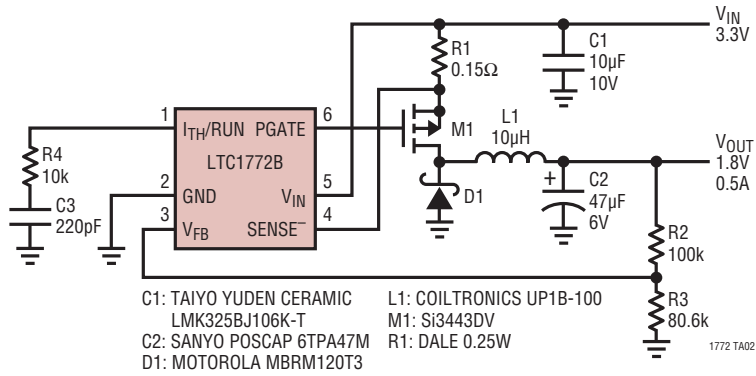

Figure 7. LTC1772B Layout Diagram (See PC Board Layout Checklist)

TYPICAL APPLICATIONS

LTC1772B High Efficiency, Small Footprint 3.3V to 1.8V/0.5A Regulator



TYPICAL APPLICATIONS

LTC1772B 5V/0.5A Flyback Regulator

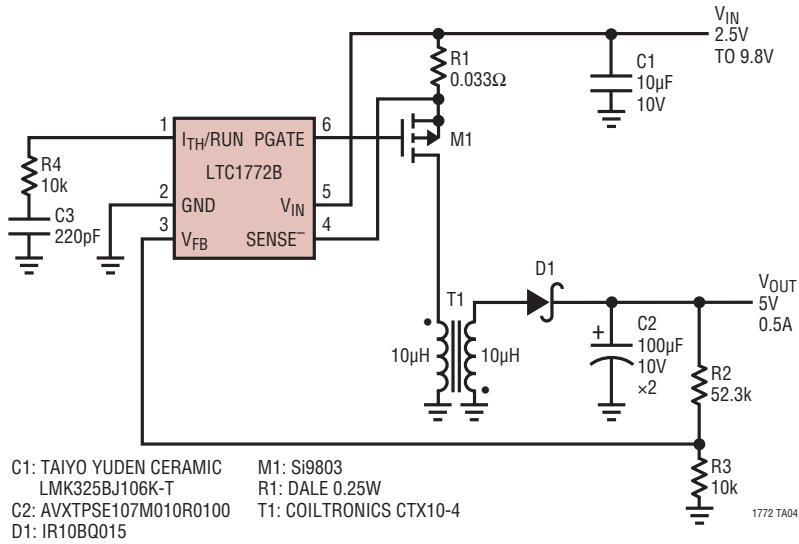

PACKAGE DESCRIPTION

S6 Package
6-Lead Plastic TSOT-23
 (Reference LTC DWG # 05-08-1636)

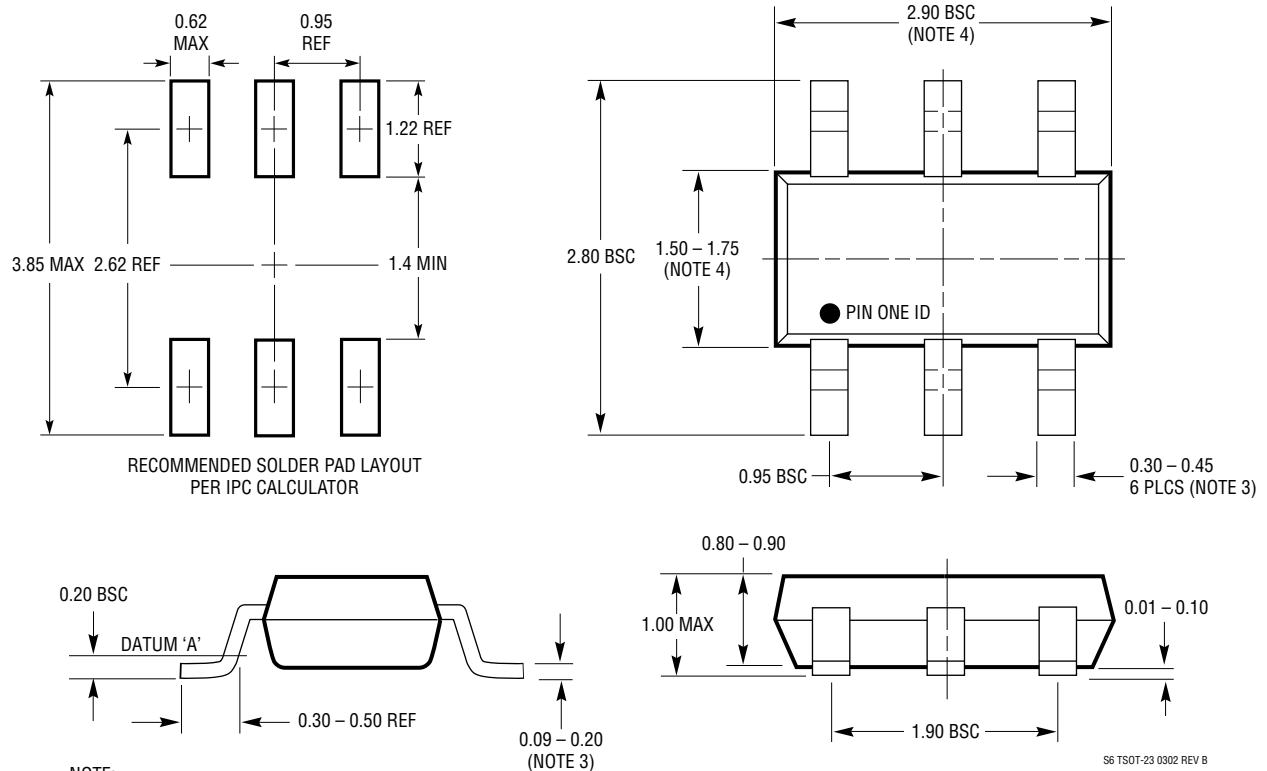

- NOTE:
1. DIMENSIONS ARE IN MILLIMETERS
 2. DRAWING NOT TO SCALE
 3. DIMENSIONS ARE INCLUSIVE OF PLATING
 4. DIMENSIONS ARE EXCLUSIVE OF MOLD FLASH AND METAL BURR
 5. MOLD FLASH SHALL NOT EXCEED 0.254mm
 6. JEDEC PACKAGE REFERENCE IS MO-193

LTC1772B

TYPICAL APPLICATION

LTC1772B 3.3V to 5V/1A Boost Regulator

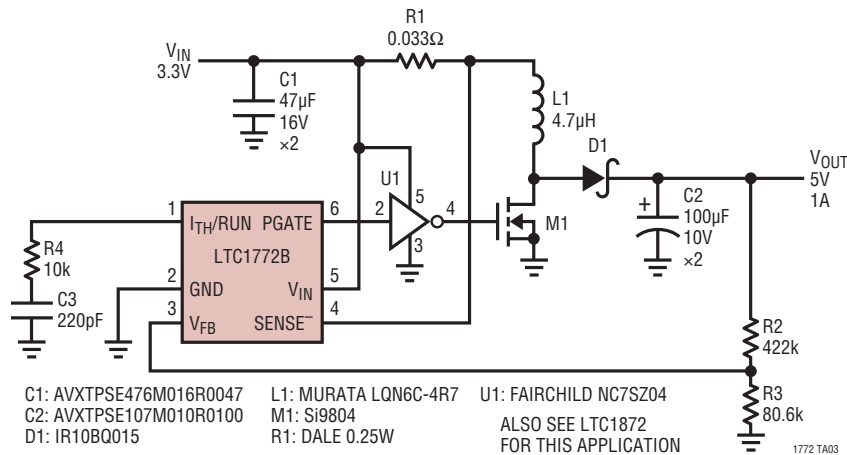

RELATED PARTS

PART NUMBER	DESCRIPTION	COMMENTS
LT1375/LT1376	1.5A, 500kHz Step-Down Switching Regulators	High Frequency, Small Inductor, High Efficiency
LTC1622	Low Input Voltage Current Mode Step-Down DC/DC Controller	V_{IN} 2V to 10V, I_{OUT} Up to 4.5A, Synchronizable to 750kHz Optional Burst Mode Operation, 8-Lead MSOP
LTC1624	High Efficiency SO-8 N-Channel Switching Regulator Controller	N-Channel Drive, $3.5V \leq V_{IN} \leq 36V$
LTC1625	No R_{SENSE}^{TM} Synchronous Step-Down Regulator	97% Efficiency, No Sense Resistor
LTC1627	Low Voltage, Monolithic Synchronous Step-Down Regulator	Low Supply Voltage Range: 2.65V to 8V, $I_{OUT} = 0.5A$
LTC1649	3.3V Input Synchronous Step-Down Controller	No Need for 5V Supply, Uses Standard Logic Gate MOSFETs; I_{OUT} up to 15A
LTC1702	550kHz, 2 Phase, Dual Synchronous Controller	Two Channels; Minimum C_{IN} and C_{OUT} ; I_{OUT} up to 15A
LTC1735	Single, High Efficiency, Low Noise Synchronous Switching Controller	High Efficiency 5V to 3.3V Conversion at up to 15A
LTC1771	Ultra-Low Supply Current Step-Down DC/DC Controller	10µA Supply Current, 93% Efficiency, $1.23V \leq V_{OUT} \leq 18V$; $2.8V \leq V_{IN} \leq 20V$
LTC1772	Constant Frequency Current Mode Step-Down DC/DC Controller in SOT-23	With Burst Mode Operation for Higher Efficiency at Light Load Current
LTC1773	95% Efficient Synchronous Step-Down Controller	$2.65V \leq V_{IN} \leq 8.5V$; $0.8V \leq V_{OUT} \leq V_{IN}$; Current Mode; 550kHz
LTC1872	SOT-23 Step-Up Controller	$2.5V \leq V_{IN} \leq 9.8V$; 550kHz; 90% Efficiency

No R_{SENSE} is a trademark of Linear Technology Corporation.

1772bfa