

FEATURES

- Programs Regulator Output Voltage from 1.3V to 2V in 50mV Steps
- Programs an Entire Family of Linear Technology DC/DC Converters
- Fully Compliant with the Intel Mobile VID Specification
- $\pm 0.25\%$ Accurate Output Voltage
- Built-In 40k Pull-Up Resistors on VID Inputs
- Available in SO-8 Packaging

APPLICATIONS

- Intel Mobile Pentium® II Processor Power Supply
- Notebook and Palmtop Computers, PDAs
- Portable Instruments
- Battery-Powered Equipment

DESCRIPTION

The LTC[®]1706-19 is a precision, digitally programmed, resistive ladder which adjusts the output of any 1.19V referenced regulator. Depending on the state of the four VID inputs, an output voltage between 1.3V and 2V is programmed in 50mV increments.

The LTC1706-19 is designed specifically to program an entire family of Linear Technology DC/DC converters in full compliance with the Intel Mobile VID specification.

The LTC1706-19 programs the following Linear Technology DC/DC converter products: LTC1433, LTC1434, LTC1435, LTC1435A, LTC1436, LTC1437, LTC1438, LTC1439, LTC1538-AUX, LTC1539, LTC1624 and LTC1625. (Consult factory for future compatible DC/DC converter products.)

LT, LTC and LT are registered trademarks of Linear Technology Corporation. Pentium is a registered trademark of Intel Corporation.

TYPICAL APPLICATION

Intel Mobile Pentium II Processor Power Supply

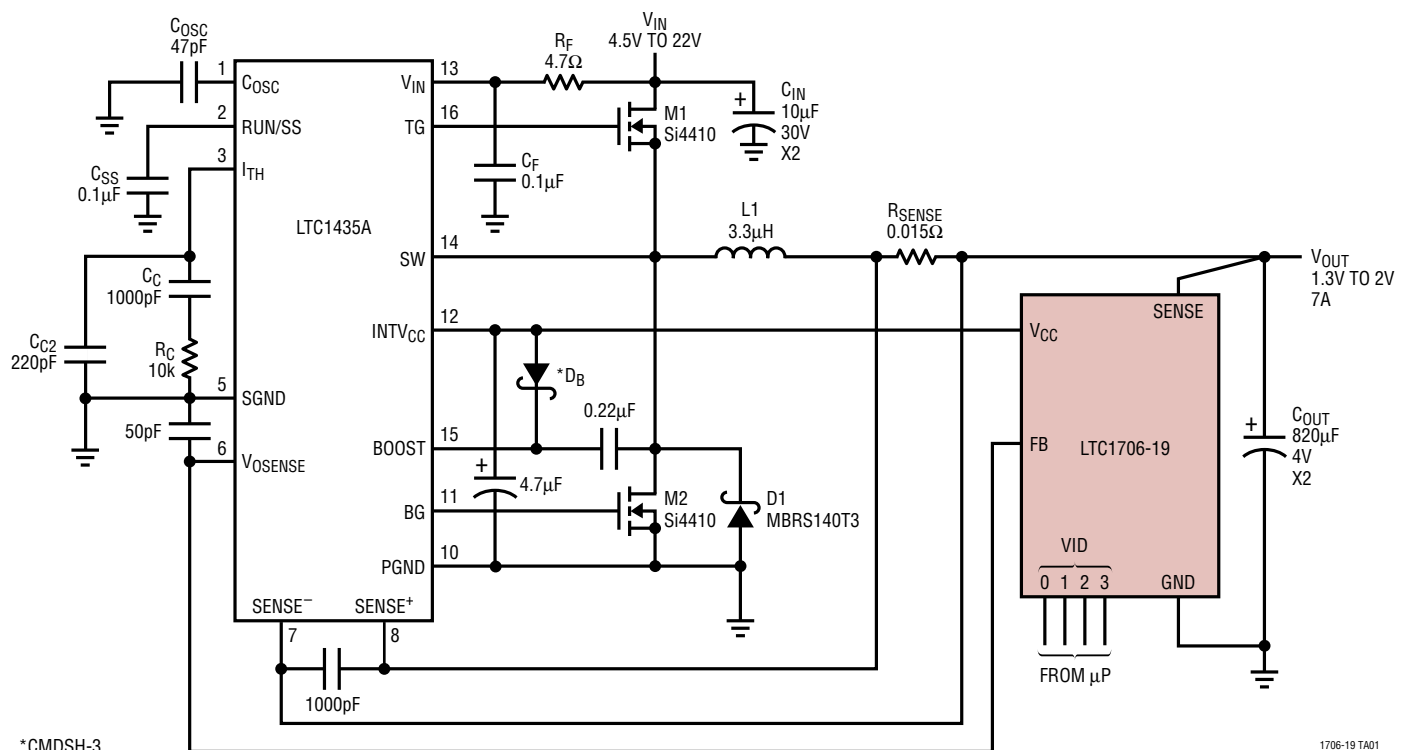

ABSOLUTE MAXIMUM RATINGS

(Note 1)

(Voltages Referred to GND Pin)

Input Supply Voltage (V_{CC})	-0.3V to 7V
VID Input Pins	-0.3V to 7V
SENSE Pin	-0.3V to 7V
FB Pin	-0.3V to 7V
Operating Temperature Range		
LTC1706C-19	0°C to 70°C
LTC1706I-19	-40°C to 85°C
Junction Temperature	110°C
Storage Temperature Range	-65°C to 150°C
Lead Temperature (Soldering, 10 sec)	300°C

PACKAGE/ORDER INFORMATION

<p>TOP VIEW</p> <p>S8 PACKAGE 8-LEAD PLASTIC SO</p> <p>$T_{jMAX} = 110^{\circ}\text{C}$, $\theta_{JA} = 120^{\circ}\text{C/W}$</p>	ORDER PART NUMBER
	LTC1706CS8-19 LTC1706IS8-19
	S8 PART MARKING
	170619 706119

Consult factory for Military grade parts.

ELECTRICAL CHARACTERISTICS

$T_A = 25^{\circ}\text{C}$, $2.7\text{V} \leq V_{CC} \leq 5.5\text{V}$, $\text{VID0} = \text{VID1} = \text{VID2} = \text{VID3} = \text{N. C.}$, unless otherwise specified.

SYMBOL	PARAMETER	CONDITIONS	MIN	TYP	MAX	UNITS
V_{CC}	Operating Supply Voltage Range		2.7		5.5	V
I_{VCC}	Supply Current	(Note 2)		0.1	5	μA
$R_{\text{FB-SENSE}}$	Resistance Between SENSE and FB		● 8	15	20	$\text{k}\Omega$
$V_{\text{OUT Error \%}}$	Output Voltage Accuracy	Programmed From 1.3V to 2V	● -0.25		0.25	%
R_{PULLUP}	VID Input Pull-Up Resistance	$V_{\text{DIODE}} = 0.6\text{V}$, $V_{CC} = 5\text{V}$, (Note 3)		40		$\text{k}\Omega$
VID_T	VID Input Voltage Threshold	$V_{\text{IL}} (2.7\text{V} \leq V_{CC} \leq 5.5\text{V})$ $V_{\text{IH}} (2.7\text{V} \leq V_{CC} \leq 5.5\text{V})$	1.6		0.4	V
$I_{\text{VID-LEAK}}$	VID Input Leakage Current	$V_{CC} < \text{VID} < 7\text{V}$, (Note 3)		0.01	± 1	μA
V_{PULLUP}	VID Pull-Up Voltage	$V_{CC} = 3.3\text{V}$ $V_{CC} = 5\text{V}$		2.8	4.5	V

The ● denotes specifications which apply over the full specified temperature range.

Note 1: Absolute Maximum Ratings are those values beyond which the life of a device may be impaired.

Note 2: With all four VID inputs floating, the V_{CC} supply current is simply the device leakage current. However, the V_{CC} supply current will rise and

be approximately equal to the number of grounded VID input pins times $(V_{CC} - 0.6\text{V})/40\text{k}$. (See the Typical Applications section for more detail.)

Note 3: Each built-in pull-up resistor attached to the VID inputs also has a series diode connected to V_{CC} to allow input voltages higher than the V_{CC} supply without damage or clamping. (See Operation section for further detail.)

TYPICAL PERFORMANCE CHARACTERISTICS

Typical Error % vs Output Voltage

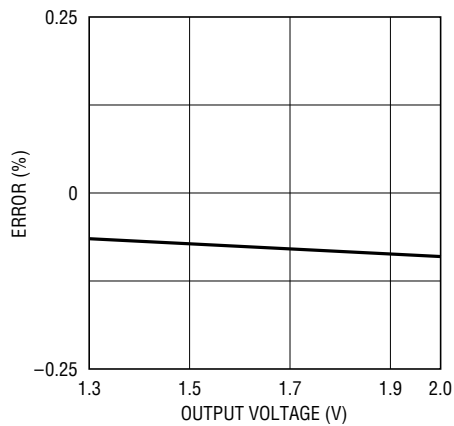

1706-19 G01

Typical Error % vs Temperature

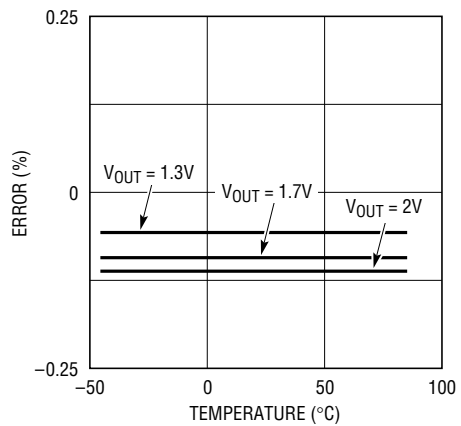

1706-19 G02

R_{FB1} vs Temperature

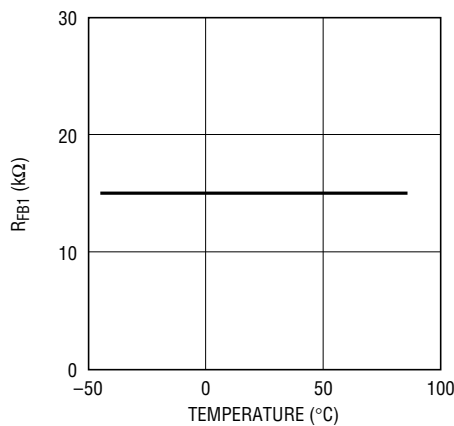

1706-19 G03

I_{VID-PULLUP} vs Temperature

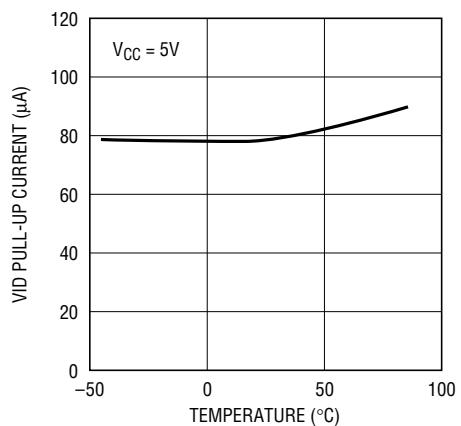

1706-19 G04

Supply Current vs Temperature

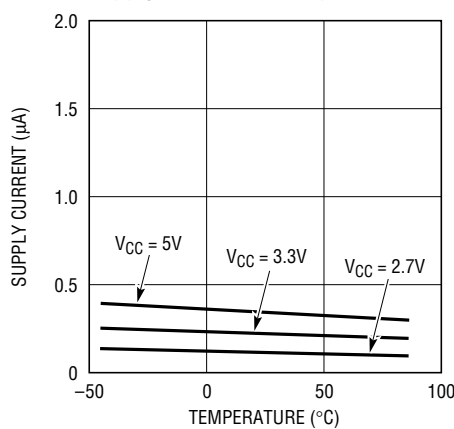

1706-19 G05

Supply Current vs Supply Voltage

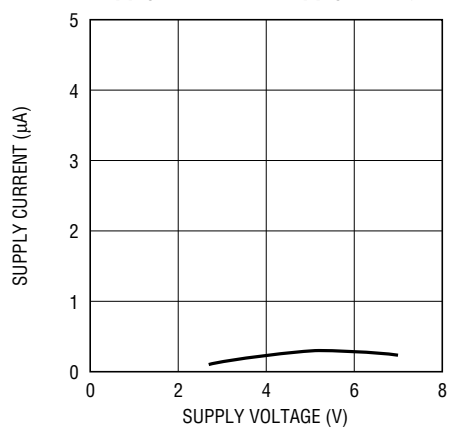

1706-19 G06

PIN FUNCTIONS

VID2 (Pin 1): 2nd MSB Programming Input. Low = GND, High = V_{CC} or Float. Grounding VID2 adds 200mV to the output sense voltage.

VID3 (Pin 2): 1st MSB Programming Input. Low = GND, High = V_{CC} or Float. Grounding VID3 adds 400mV to the output sense voltage.

V_{CC} (Pin 3): Power Supply Voltage. Range from 2.7V to 5.5V.

GND (Pin 4): Ground. Connect to regulator signal ground.

FB (Pin 5): Feedback Input. Connect to the 1.19V feedback pin of a compatible regulator.

SENSE (Pin 6): Regulator Output Voltage. Connect directly to regulator output sense node.

VID0 (Pin 7): LSB Programming Input. Low = GND, High = V_{CC} or Float. Grounding VID0 adds 50mV to the output sense voltage.

VID1 (Pin 8): 3rd MSB Programming Input. Low = GND, High = V_{CC} or Float. Grounding VID1 adds 100mV to the output sense voltage.

PIN	NAME	DESCRIPTION	NOMINAL (V)			ABSOLUTE MAX (V)	
			MIN	TYP	MAX	MIN	MAX
1	VID2	2nd MSB Programmable Input	0		V_{CC}	-0.3	7
2	VID3	1st MSB Programmable Input	0		V_{CC}	-0.3	7
3	V_{CC}	Power Supply	2.7		5.5	-0.3	7
4	GND	Ground		0		0	0
5	FB	1.19V Feedback Input	0	1.19	1.5	-0.3	7
6	SENSE	Regulator Output Voltage	1.3		2	-0.3	7
7	VID0	LSB Programmable Input	0		V_{CC}	-0.3	7
8	VID1	3rd MSB Programmable Input	0		V_{CC}	-0.3	7

BLOCK DIAGRAM

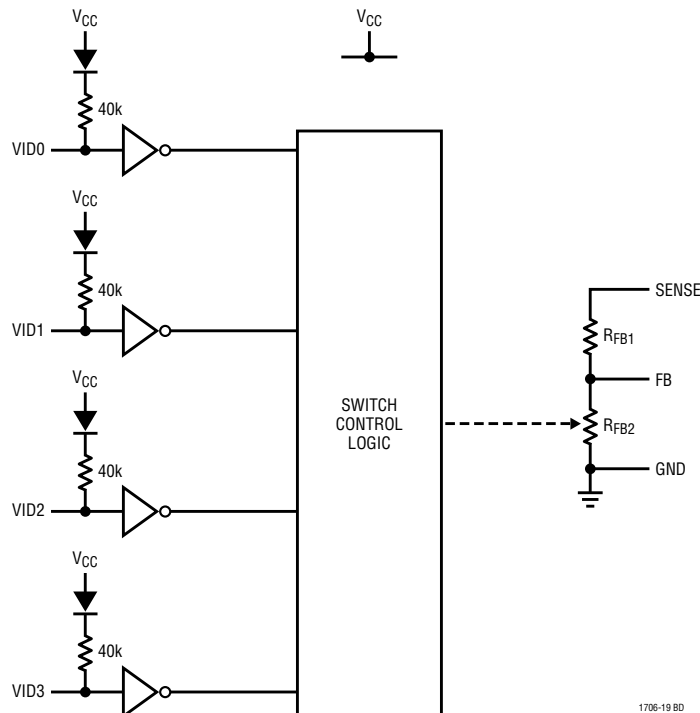

OPERATION

The LTC1706-19 is a precision resistive divider designed specifically for use with an entire family of Linear Technology Corporation DC/DC switching regulators with 1.19V internal reference and feedback voltages. The LTC1706-19 produces an output voltage ranging from 1.3V to 2V in 50mV steps by closing the loop between the output voltage sense and the feedback input of the regulator with the appropriate resistive divider network.

The “top” feedback resistor, R_{FB1} , connected between SENSE and FB, is typically 15k and is not modified by the state of the VID program inputs. However, the “bottom” feedback resistor, R_{FB2} , is modified by the four VID inputs and is precisely ratioed to R_{FB1} .

VID Programming

Programming is accomplished by applying the proper voltage (or float condition) on the four digital VID inputs. VID3 is the most significant bit (MSB), and VID0 is the least significant bit (LSB). When all four inputs are low, or grounded, the regulator output voltage is set to 2V. Each increasing binary count is equivalent to a decrease of 50mv in the output voltage. Therefore, to obtain a 1.3V output, the three MSBs are left floating, or high, while only the LSB, VID0, is grounded. A list of programmed inputs and their corresponding output voltages is shown in Table 1.

When all four VID inputs are high or floating (1111), such as when no CPU is present in a system, a regulated 1.25V output is generated at V_{SENSE} .

Each VID input pin is pulled up by a 40k resistor in series with a diode connected to V_{CC} . Therefore, it should be grounded (or driven low) to produce a digital low input. It can be either floated or connected to V_{CC} to get a digital high input. The series diode is included to prevent the input from being damaged or clamped if it is driven higher than V_{CC} .

Table 1. VID Inputs and Corresponding Output Voltage

CODE	VID3	VID2	VID1	VID0	OUTPUT
0000	GND	GND	GND	GND	2.00V
0001	GND	GND	GND	Float	1.95V
0010	GND	GND	Float	GND	1.90V
0011	GND	GND	Float	Float	1.85V
0100	GND	Float	GND	GND	1.80V
0101	GND	Float	GND	Float	1.75V
0110	GND	Float	Float	GND	1.70V
0111	GND	Float	GND	GND	1.65V
1000	Float	GND	GND	GND	1.60V
1001	Float	GND	GND	Float	1.55V
1010	Float	GND	Float	GND	1.50V
1011	Float	GND	Float	Float	1.45V
1100	Float	Float	GND	GND	1.40V
1101	Float	Float	GND	Float	1.35V
1110	Float	Float	Float	GND	1.30V

Voltage Sensing and Feedback Pins

The FB pin is a high impedance node that requires minimum layout distance to reduce extra loading and unwanted stray pickup.

When used with the LTC1435A, the LTC1706-19's FB, SENSE, V_{CC} and GND pins should be connected, respectively, with the V_{OSENSE} , V_{OUT} , $INTV_{CC}$ and SGND pins of the LTC1435A. The result of this application is a precisely controlled variable voltage supply for any low voltage system such as a palmtop or a laptop computer.

OPERATION

VID Input Characteristics

The VID inputs should be driven with a maximum V_{IL} of 0.4V and a minimum V_{IH} of 1.6V. However, the VID input range is not limited to values below V_{CC} . Because of the diode between V_{CC} and the pull-up resistor, the inputs can go higher than V_{CC} without being bootstrapped to V_{CC} or damaging the input. This allows the LTC1706-19 to be logic compatible and operational over a much higher input voltage range (less than the 7V absolute maximum rating).

When a VID input is grounded, there will be a higher quiescent current flow from V_{CC} because of a resistor from V_{CC} through a series diode to the input. This increase in quiescent current is calculated from

$$N \cdot (V_{CC} - V_{DIODE}) / R_{PULLUP}$$

N is the number of grounded VID inputs.

V_{DIODE} is typically 0.6V while R_{PULLUP} has a typical pull-up resistance of 40k Ω . In other words, each VID input has a typical pull-up current of $(V_{CC} - 0.6V) / 40k$, which is approximately 68 μ A for a 3.3V system.

TYPICAL APPLICATIONS

450mA, Low Noise Monolithic Current Mode Step-Down DC/DC Converter

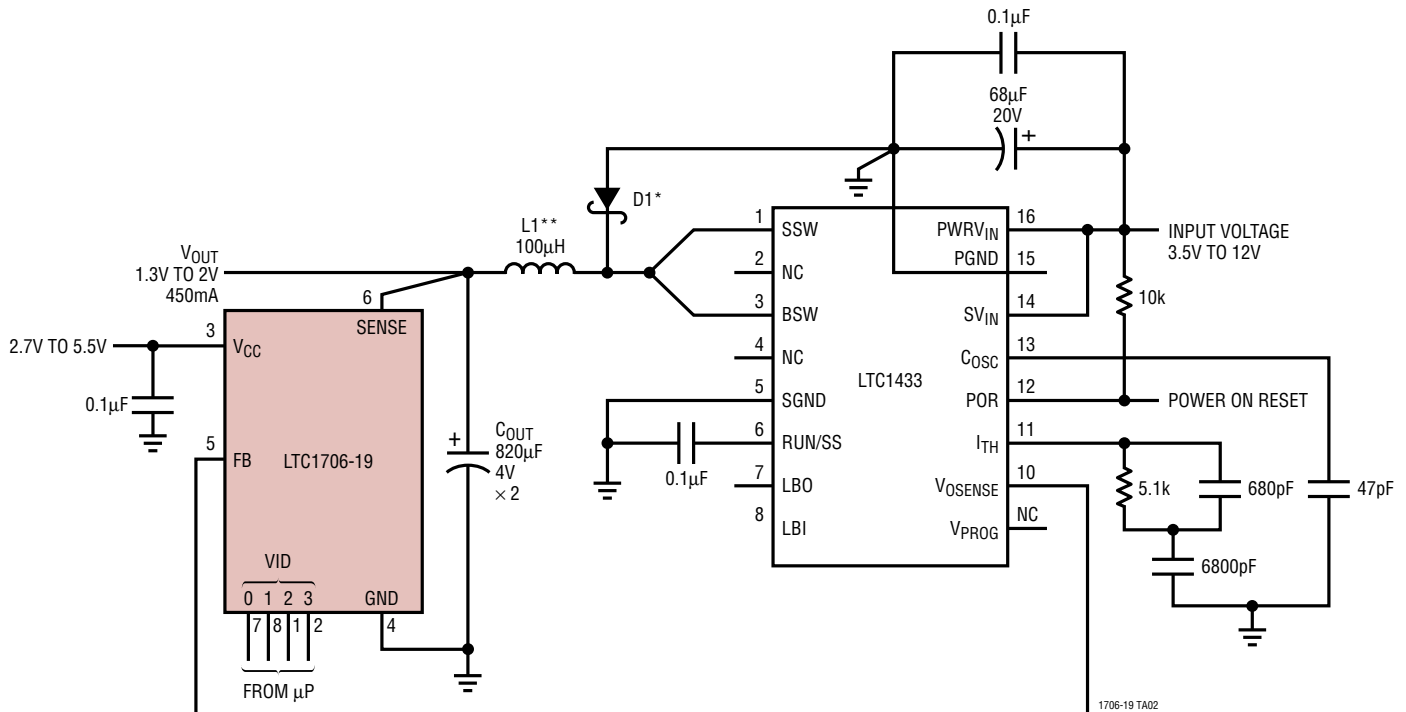

* MOTOROLA MBRS130LT3
 ** COILCRAFT D03316-104

TYPICAL APPLICATIONS

High Efficiency Low Noise Synchronous Step-Down Switching Regulator

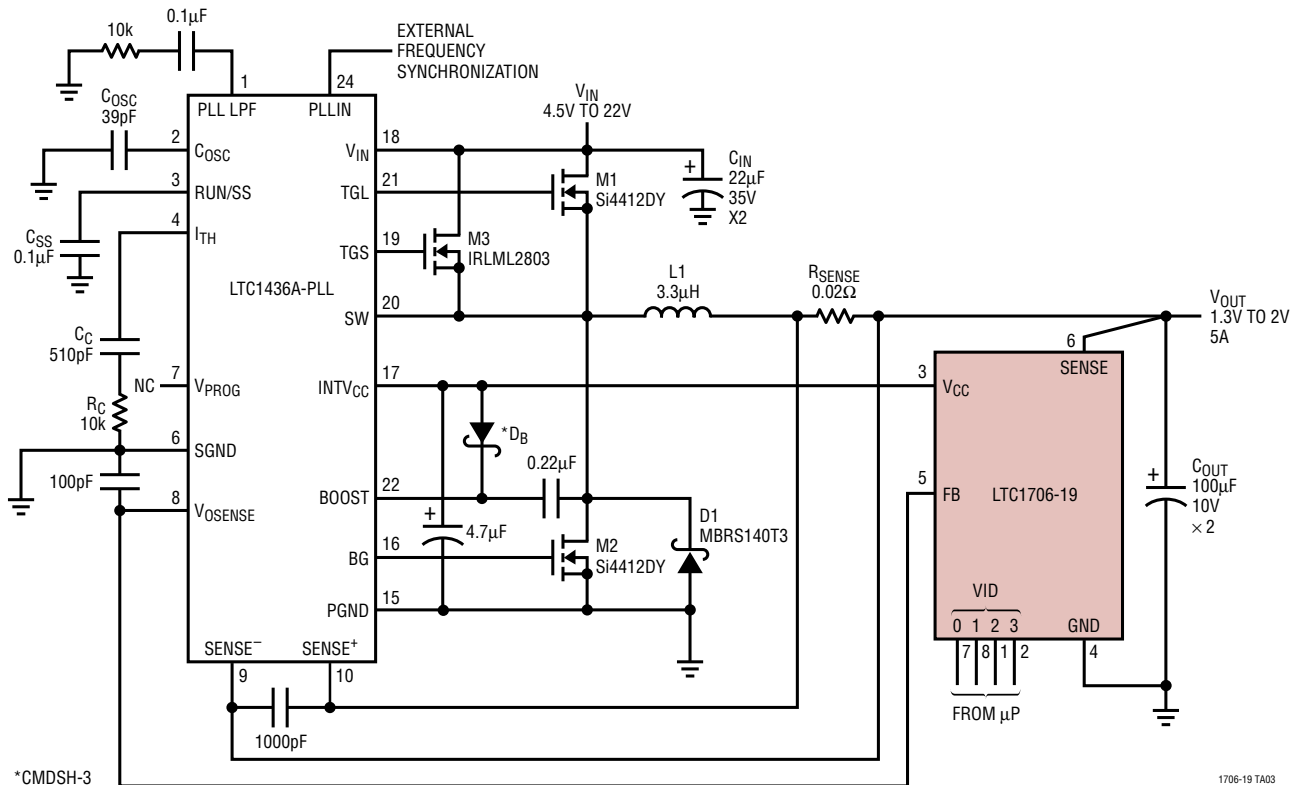

Ultrafast Transient Response Low Dropout Regulator with Adjustable Output Voltage

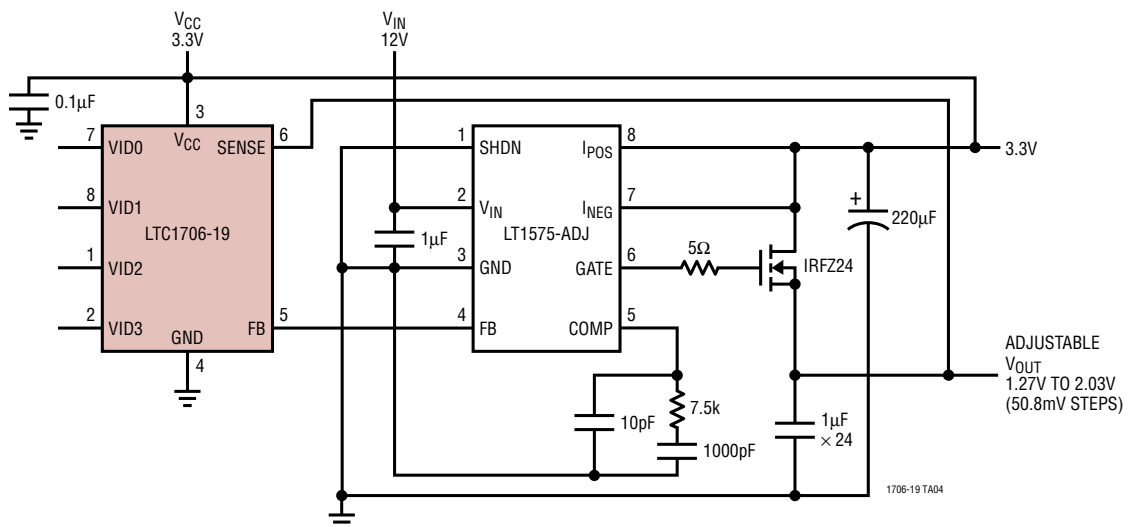

Used with the LT1575-ADJ, which has a 1.21V reference, the LTC1706-19 programs the output voltage of the ultrafast transient response low dropout regulator that's ideal for today's power-hungry microprocessors. How-

ever, since the LT1575 does not have a 1.19V reference, the output range will instead be from 1.27V to 2.03V in steps of 50.8mV.

TYPICAL APPLICATIONS

High Efficiency 3A SO-8 N-Channel Switching Regulator with Programmable Output

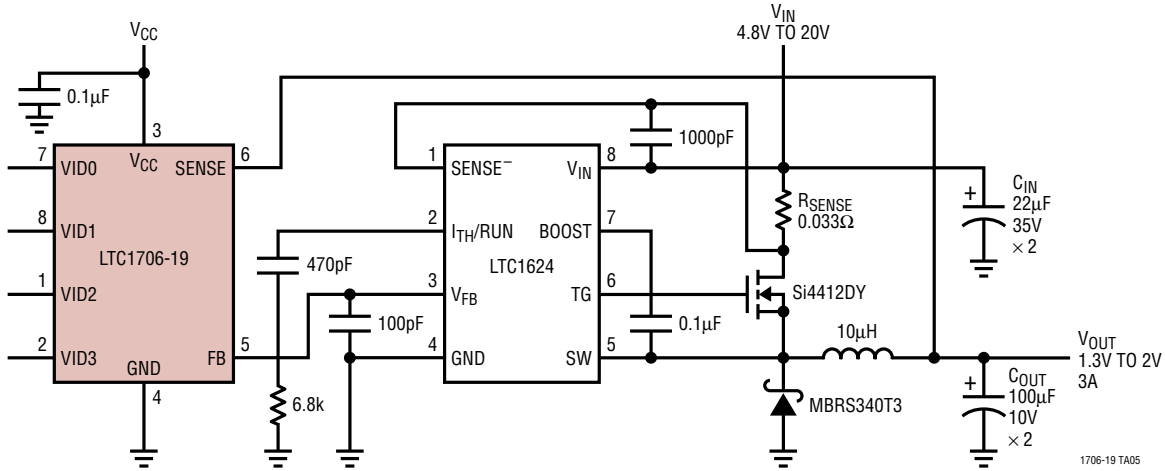

1706-19 TA05

PACKAGE DESCRIPTION Dimensions in inches (millimeters) unless otherwise noted.

S8 Package 8-Lead Plastic Small Outline (Narrow 0.150) (LTC DWG # 05-08-1610)

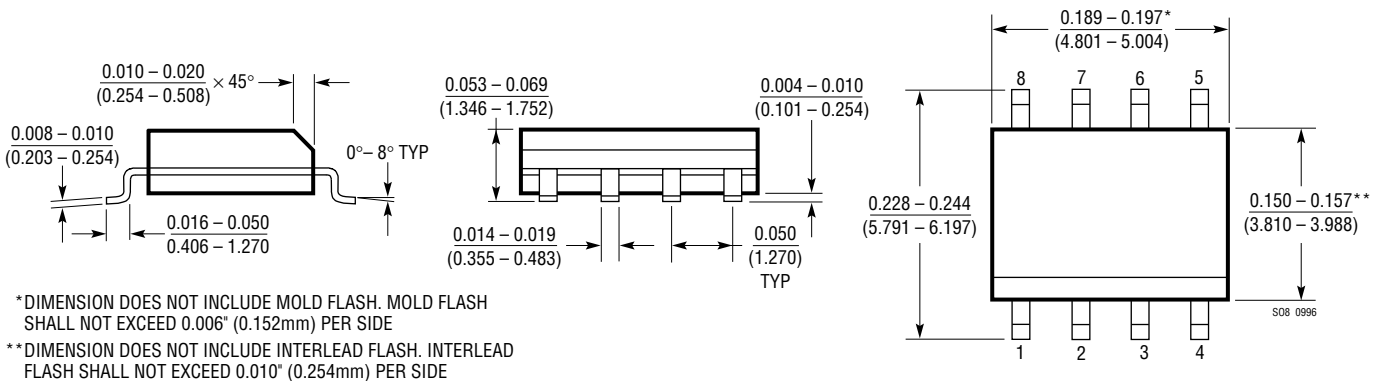

RELATED PARTS

PART NUMBER	DESCRIPTION	COMMENTS
LTC1174/LTC1174-3.3	High Efficiency Step-Down and Inverting DC/DC Converter	Monolithic Switching Regulator, Burst Mode™ Operation
LTC1265	1.2A, High Efficiency Step-Down DC/DC Converter	Constant Off-Time Monolithic, Burst Mode Operation
LT1375/LT1376	1.5A, 500kHz Step-Down Switching Regulator	High Frequency, Small Inductor, High Efficiency
LTC1435/LTC1435A	High Efficiency, Low Noise, Synchronous Step-Down Converter	16-Pin Narrow SO and SSOP
LTC1436/LTC1436-PLL	High Efficiency, Low Noise, Synchronous Step-Down Converter	24-Pin Narrow and 24-Pin SSOP
LTC1438/LTC1439	Dual, Low Noise, Synchronous Step-Down Converter	Multiple Output Capability
LTC1538-AUX	Dual, Low Noise, Synchronous Step-Down Converter	5V Standby Regulator in Shutdown

Burst Mode is a trademark of Linear Technology Corporation.